

DXP-62

Digital Xtreme Scaler/Switcher

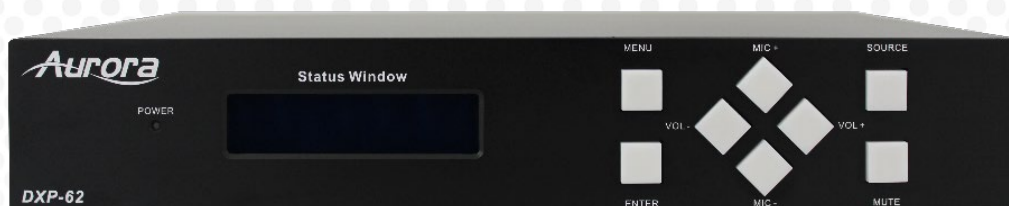

SAFETY INSTRUCTIONS

Please review the following safety precautions. If this is the first time using this model, then read this manual before installing or using the product. If the product is not functioning properly, please contact your local dealer or Aurora for further instructions.



The lightning symbol in the triangle is used to alert you to the presence of dangerous voltage inside the product that may be sufficient to constitute a risk of electric shock to anyone opening the case. It is also used to indicate improper installation or handling of the product that could damage the electrical system in the product or in other equipment attached to the product.



The exclamation point in the triangle is used to alert you to important operating and maintenance instructions. Failure to follow these instructions could result in injury to you or damage to the product.



Be careful with electricity:

- **Power Outlet:** To prevent electric shock, be sure the electrical plug used on the product power cord matches the electrical outlet used to supply power to the Aurora product. Use the power adapter and power connection cables designed for this unit.
- **Power Cord:** Be sure the power cord is routed so that it will not be stepped on or pinched by heavy items.
- **Lightning:** For protection from lightning or when the product is left unattended for a long period, disconnect it from the power source.



Also follow these precautions:

- **Ventilation:** Do not block ventilation slots, if applicable, on the product, or place any heavy object on top of it. Blocking airflow could cause damage. Arrange components so that air can flow freely. Ensure that there is adequate ventilation if the product is placed in a stand or cabinet. Put the product in a properly ventilated area, away from direct sunlight or any source of heat.
- **Overheating:** Avoid stacking the Aurora product on top of a hot component, such as a power amplifier.
- **Risk of Fire:** Do not place unit on top of any easily combustible material, such as carpet or fabric.
- **Proper Connections:** Be sure all cables and equipment are connected to the unit as described in this manual.
- **Object Entry:** To avoid electric shock, never stick anything in the slots on the case, or remove the cover.
- **Water Exposure:** To reduce the risk of fire or electric shock, do not expose to rain or moisture.
- **Cleaning:** Do not use liquid or aerosol cleaners to clean this unit. Always unplug the power to the device before cleaning.
- **ESD:** Handle this unit with proper ESD care. Failure to do so can result in failure.

FCC

This device complies with Part 15 of the FCC Rules. Operation is subject to the following two (2) conditions:

1. This device may not cause harmful interference.
2. This device must accept any interference received, including interference that may cause undesired operation.



Trademarks

All trademarks in this document are the properties of their respective owners.

TABLE OF CONTENTS

PACKAGE CONTENTS	3
INTRODUCTION	4
About	4
Features	4
DXP-62 Front	5
DXP-62 Rear	6
CONNECTION	7
System Diagram.....	7
Connection Procedure	7
Connection of Microphone	8
Application.....	10
OPERATION	11
Buttons	11
Resolution Switching.....	11
Software Updating.....	12
Volume	12
OSD Menu.....	12
OSD Menu Operations	13
CEC Function	16
RS232 Control.....	16
VGA Converting Cable.....	24
APPENDIX 1	25
Troubleshooting	25
APPENDIX 2	26
Technical Specifications.....	26
APPENDIX 3	28
Cabling	28
APPENDIX 4	29
Warranty.....	29

PACKAGE CONTENTS

Please make sure the following items are included within your package. Contact your dealer if any items are missing or damaged.

- 1 x DXP-62
- 2 x Mounting Ears (separate from the DXP-62)
- 1 x Power Cable (DC 12V)
- 1 x RS232 Cable
- 2 x VGA converting cables (male VGA to female YPbPr, length: 400 mm)
- 7 x Captive screw connectors
- 4 x Screws (black color)
- 6 x Plastic Cushions

***Note:** Go to www.auroramm.com for latest manual and firmware.

INTRODUCTION

About

The DXP-62 is the latest presentation scaler switcher innovation from Aurora; designed to be a low cost full featured high end scaler with a variety of input ports to accommodate legacy and today's technology. The VGA ports also can process YPbPr component video and composite video for the ultimate in flexibility. Four HDMI inputs provide plenty of digital inputs for the ultimate clarity with the latest equipment. To further simplify an installation, the DXP-62 has an integrated HDBaseT extender output in addition to the HDMI output which can power the remote receiver unit (DXE-CAT-RX1) and send the RS-232 control to the far end display device. If an amplifier, screen control, web control, and ceiling tile speakers are required, the DXE-AT-RX3C-A with SKR-22T can be selected to create a complete end to end solution. Even the little things can make a big difference like auto sensing switching, stereo analog and microphone audio inputs, and RS-232 control making the DXP-62 the complete presentation solution.

Features

- ◆ 4 HDMI Inputs
- ◆ 2 VGA/YPbPr/Composite Inputs
- ◆ 4 Analog Audio Stereo Inputs
- ◆ 1 Microphone Input
- ◆ 1 HDMI Output
- ◆ 1 HDBaseT Output 230' (70m) CAT 5e/6
- ◆ Power Over HDBaseT (PoH)
- ◆ IR and RS-232 Over HDBaseT
- ◆ Scales input up to 1080p
- ◆ Auto Switching Feature
- ◆ Front Panel Button Control
- ◆ Front Panel LCD Display
- ◆ OSD (On Screen Display)
- ◆ RS-232 Control
- ◆ USB for Firmware Updating
- ◆ Designed to work with DXE-CAT-RX, DXE-CAT-RX3-A, and DXW-2-RX1 HDBaseT Receivers



DXP-62 Front

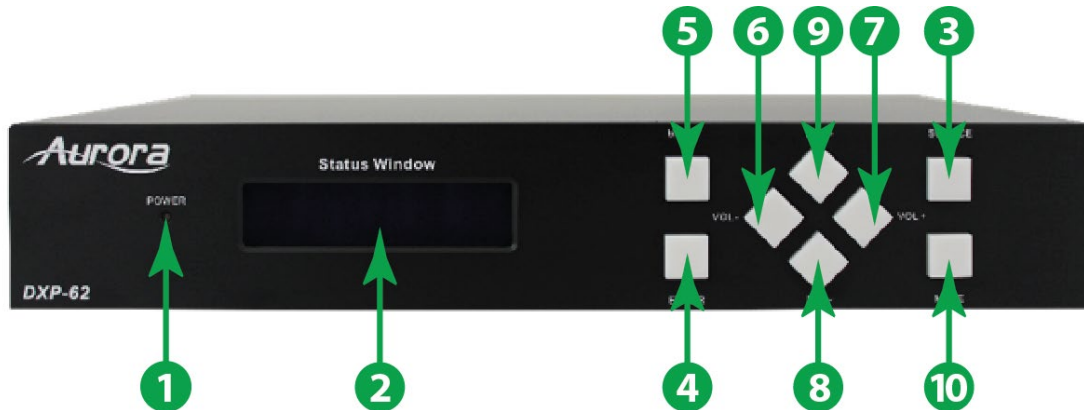

1. **Power Indicator:** Turns green when power on, red when in standby mode.
2. **LCD:** Shows the real-time system working status.
3. **Source:** Used as video source selection button, press to select one source, press again to select next source, switching circularly between HDMI1, HDMI2, HDMI3, VGA1 and VGA2. The LCD screen will show the name of selected source.
4. **Enter:** Used to confirm selection when in menu.
5. **Menu:** Used as menu button, press it to enter in OSD menu.
6. **Vol -:** Used as volume down button. Used as direction button NEXT when in menus.
7. **Vol +:** Used as volume up button. Used as direction button PREVIOUS when in menus.
8. **Mic -:** Used as volume up button. Used as direction button PREVIOUS when in menus.
9. **Mic +:** Used as MIC volume up button. Used as direction button MOVE UP when in menus.
10. **Mute:** Used as MUTE volume button.

DXP-62 Rear

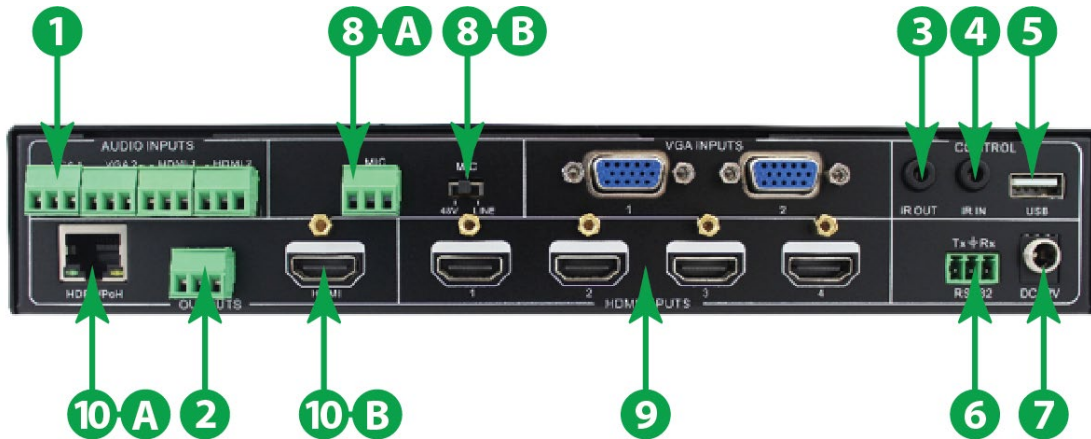

1. **Audio Input:** 2 HDMI audio & 2 VGA audio inputs. User can choose any one audio (embedded HDMI audio or external input audio) for HDMI audio input by using RS232 commands.
2. **Audio Output:** Audio output port, the audio comes from the input audio corresponding to the selected video source and mixed with MIC audio.
3. **IR Out:** Connects with IR emitter, used to control local source device or the DXP-62 from remote, switches following the corresponding video source.
4. **IR In:** Connects with IR receiver (with carrier wave only), to receive IR signal send by the IR remote or remote controller of other input or output device.
5. **Firmware:** USB port connects with USB flash disk or other storage which is with update file inside, to update the system firmware.
6. **RS-232:** Serial control port, 3p captive screw connector, connects with a control device (such as a computer) to control the DXP-62 or other device connected with the HDMI twisted pair PoH receiver.
7. **12V DC:** Power port. Connects with the 12V DC power adapter.
8. **Mic:** 8A) MIC port, connects with microphone; 8B) 3 position switch: 48V phantom power mode (connects with condenser microphone), MIC mode (connects with dynamic microphone) and LINE mode (connects with wireless microphone or line audio).
9. **Video Input:** Video input ports, includes 4 HDMI inputs and 2 VGA inputs. VGA ports supports YPbPr, Composite Video and VGA format. Factory default is VGA format.
10. **Output:** 10A) HDMI local output. 10B) HDBaseT output. The audio part of the two ports are same, and is mixed with MIC audio and HDMI embedded audio (output audio), and if disable HDMI embedded audio output, then there will be no audio output through these ports.

CONNECTION

System Diagram

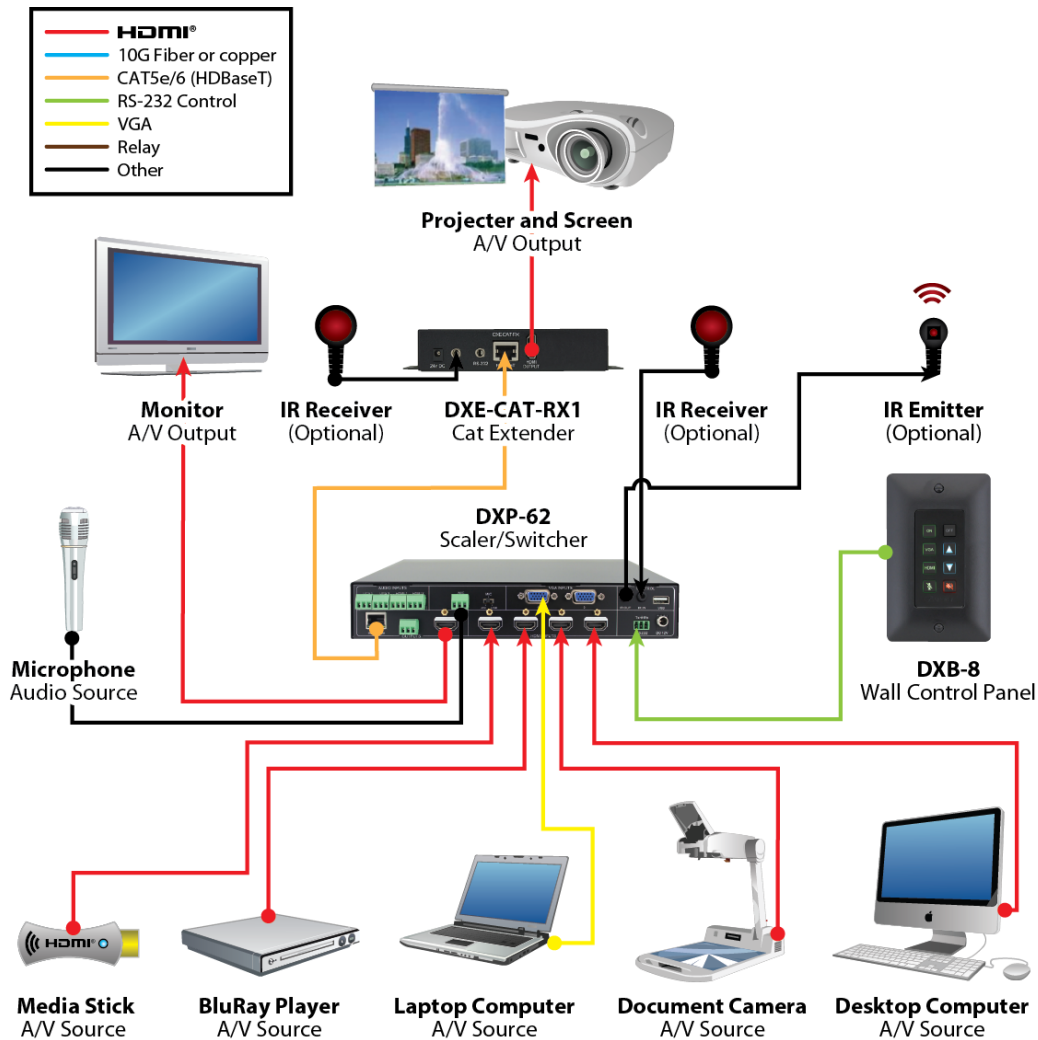

Connection Procedure

- Connect HDMI source devices (e.g. Blue-ray DVD) to HDMI input ports of the DXP-62 with HDMI cable. Connect VGA source device (e.g., PC) to VGA input ports of the DXP-62 with VGA cable.
- Connect the corresponding audio source to the corresponding AUDIO INPUT port of the DXP-62 with audio cable one to one. The audio of HDMI can be embedded or external by sending right command.
- Connect HDMI display device to HDMI output port of the DXP-62 with HDMI cable.
- Connect the HDMI twisted pair PoH receiver to HDBaseT output port of the scaler switcher with twisted pair.
- Connect speaker, headphone or specialized amplifier to AUDIO OUTPUT port of the DXP-62.
- Connect control device (e.g., PC) to RS232 port of **DXM-62** or the receiver (bi-directional RS232 control, either is available).

- Both the DXP-62 and the receiver have IR IN and OUT. When one model is used for IR signal receiver, the IR signal must be sent out by the other model. For example: When “IR IN” of the DXM-62 connects with an IR receiver, the IR transmitter must connect to IR OUT of the receiver.
- The IR signal can be transmitted bi-directionally between the DXP-62 and the receiver.
- Select MIC level and connect right microphone to MIC input port. MIC audio will be transmitted to AUDIO OUTPUT port and mixed with source audio.
- Connect DC12V power adaptor to the power port (the receiver is able to get power from the DXP-62).

Connection of Microphone

The DXP-62 provides with one 3 position microphone input, to accommodate different microphone input modes, including 48V phantom power mode, MIC mode and LINE mode.

48B Phantom Power Input

When switch to “48V” (It has a good frequency characteristic, high input impedance and high sensitivity in this mode), the MIC input will provide a 48V phantom power. This is only used for **condenser microphone**.

Connection is: “+” connects to positive, “-” connects to negative and “ \equiv ” to ground.

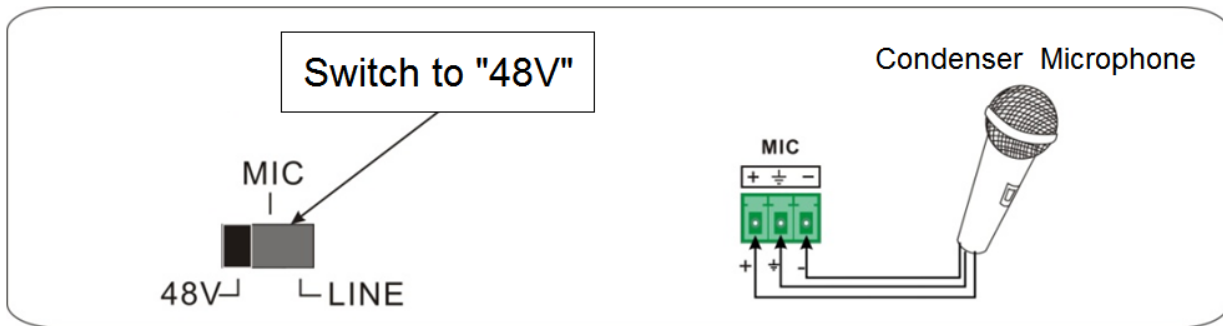

MIC Input

When switch to "MIC" (It has a low frequency characteristics, and wide frequency response in this mode), the microphone input is used for connecting with **dynamic microphone**. There are two different connections:

- Unbalanced Connection:

"+" and "⏏" connect to ground, and "-" connects to signal.

"-" and "⏏" connect to ground, and "+" connects to signal.

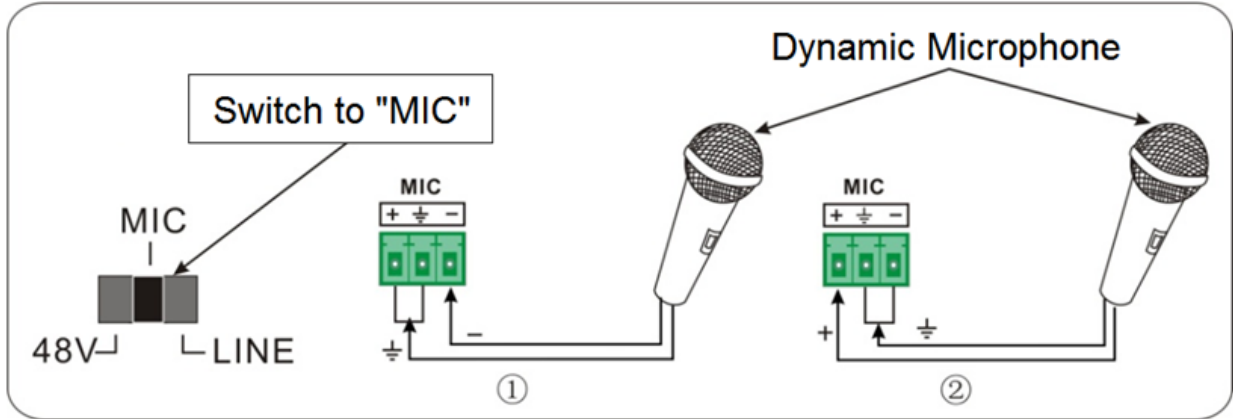

- Balanced Connection: "+" connects to positive, "-" connects to negative and "⏏" connects to ground.

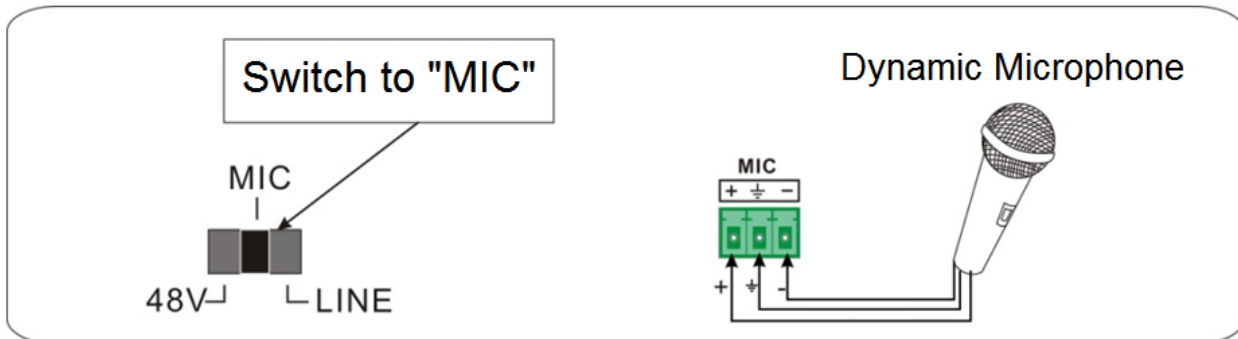

LINE Input

When switch to "LINE" (It has a low frequency characteristics, and wide frequency response in this mode), the microphone input is used for connecting with line audio or wireless microphone output. There are 2 different connections:

- Unbalanced Connection:

"+" and "⏏" connect to ground, and "-" connects to signal.

"-" and "⏏" connect to ground, and "+" connects to signal.

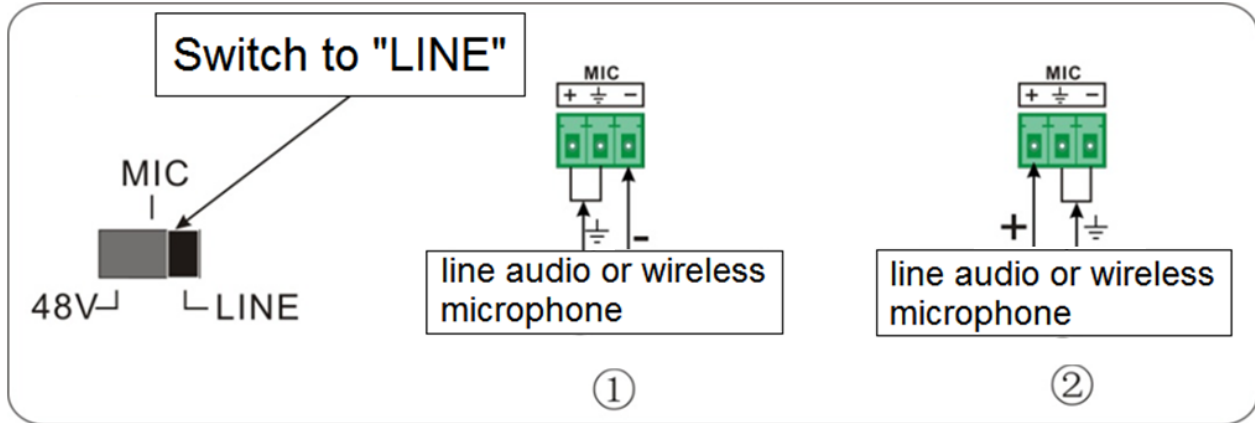

- Balanced Connection: "+" connects to positive, "-" connects to negative and "⏏" connects to ground.

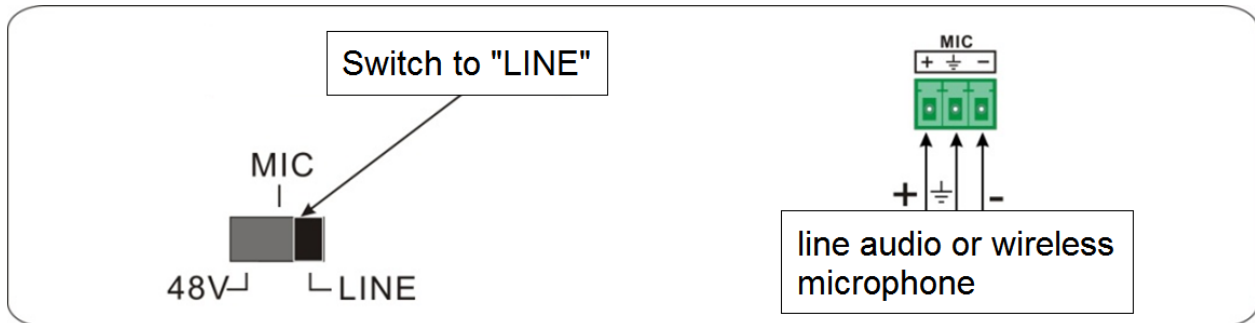

Application

Rolling Cart/Credenza/Podium Application

This highly integrated technology when used with the DXE-CAT-RX3C-A allows a rolling cart or podium to use a single CAT 5e/6 cable as the umbilical to the wall plate. The DXP-62 mounts inside the structure along with the computer, document camera, Blu-ray player, auxiliary input panel, etc. These devices will plug into the DXP-62 video and audio inputs accordingly. The HDMI output of the DXP-62 can be used on the cart's local monitor while the HDBaseT CAT is connected to the RJ-45 jack on the back of the cart or podium. A standard CAT 5e cable will connect the cart or podium to the wall plate which will pass the signal to the projector's location. At the projector the DXE-CAT-RX3C-A will receive the signal and split out the HDMI and RS-232 control. Since the DXE-CAT-RX3C-A has an amplifier integrated, it can be easily used with the Aurora SKR-22T 25 watt flat ceiling tile speaker capable of 180 degree sound. For remote motorized screen control the DXE-CAT-RX3C-A has 2 relays to allow up/down functionality. The built in IP control allows the operator to automate the system locally or remotely via web pages. Thousands of rooms can be controlled from any device with a web browser like a PC, iPad®, iPhone®, Android®, etc.

OPERATION

Buttons

The buttons can be used for output resolution adjusting, switching operations, software updating, volume adjusting and operations in menus.

Resolution Switching

Supports auto-adjusting and manual-adjusting. Press and hold on **SOURCE** button for **7 seconds or more** to enter in auto-adjusting/manual-adjusting mode.

**Note: In auto-adjusting mode, DXP-62 will choose the resolution of the display device at the far-end as the preferred resolution. If you need to choose the resolution of local HDMI display device:*

- *Cut off the power of DXP-62 and break the connection between DXP-62 and DXE-CAT-RX1.*
- *Turn on the power of DXP-62.*
- *Gets the resolution of local HDMI output device.*
- *Connect DXE-CAT-RX1 to DXP-62.*

In auto-switching mode, front panel button control is not available, but IR and RS232 control is able to switch modes.

Supports auto-switching and manual-switching. Press and hold on **SOURCE** button for **7 seconds or more** to enter in auto-switching/manual-switching mode.

The display result is showed as below:



The display result will be showed for **2 seconds**.

Auto-Switching Function

- **New Input:** Once detecting a new input signal, the DXP-62 would switch to this new signal automatically.
- **Power Rebooting:** The DXP-62 offers the function to remember the signal last displayed when rebooting. Once rebooting, it will automatically enter in auto-switching mode, and then detect all inputs and memorize their connection status for future rebooting using. And if the signal last displayed is still available, then it will choose the signal to output. If not, there will be no signal on outputs.
- **Signal Removing:** Once removing the current display signal, the DXP-62 will detect all input signals with priority from INPUT 1 to INPUT 5. It will transfer the signal firstly detected to be available to outputs.

**Note: Auto-switching function works only when input with new signal, remove a signal or power rebooting. With any VGA port set to AV or YPbPr, the system will be not able to enter in Auto-switching mode.*

Operation Examples

- Connect the INPUT 2, INPUT 4, and INPUT 5 ports to the source devices, select INPUT 4 to outputs.
- Press and hold on the front key **SOURCE** for **7 seconds or more** to enter in auto-switching mode.
- No signal removing or new input, the DXP-62 just works in auto-switching mode, and will take no action (Output from INPUT 4)
- Connect INPUT 3 with a source device, and then it will choose INPUT 3 to output.
- Remove the signal of INPUT 3, the DXP-62 will detect from INPUT 1 to INPUT 5. When it detects that input 2 is available, it will choose INPUT 2 to output.
- Cut off the power of the DXP-62, then reboot. With the DXP-62 is in auto-switching mode, it will choose INPUT 2 to output.

Software Updating

Software updating means to update the inside program of the DXP-62. The DXP-62 supports software updating via USB memory stick.

Operation

- Copy the file “DXP-62.bin” to the root directory of a USB memory stick. (Make sure the file is copied to the root directory for normal use. The “DXP-62.bin” file is provided/authorized by our engineering department or from the Aurora website customer portal).
- Plug the USB memory stick to the DXP-62 USB port.
- Press the button “MENU” for 7 seconds or more to update the software automatically.
- Or press this button for 6 seconds until it comes out an update OSD and then select “Option” → “Software Update” to enter in update procedure.

Volume

- Not in OSD menu, press VOL -- to decrease line volume, VOL + to increase.
- Not in OSD menu, press MIC – to decrease MIC volume, MIC + to increase.

OSD Menu

- Press **MENU** button to enter in OSD menu, and use **UP**, **DOWN**, **LEFT**, **RIGHT** button to select.
- Press **ENTER** button to confirm selection.
- The **MENU** button also can be used to exit present menu level by level until exit the OSD menu.

OSD Menu Operations

The DXP-62 provides a powerful OSD operation menu, contains 4 parts: option settings, image settings, audio settings and system settings. Press MENU button on front panel to enter into OSD menu.

Option

Includes Output Adjust, Input4/5 Select, HDMI1/2/3/4 Audio select, and Software Update (USB).

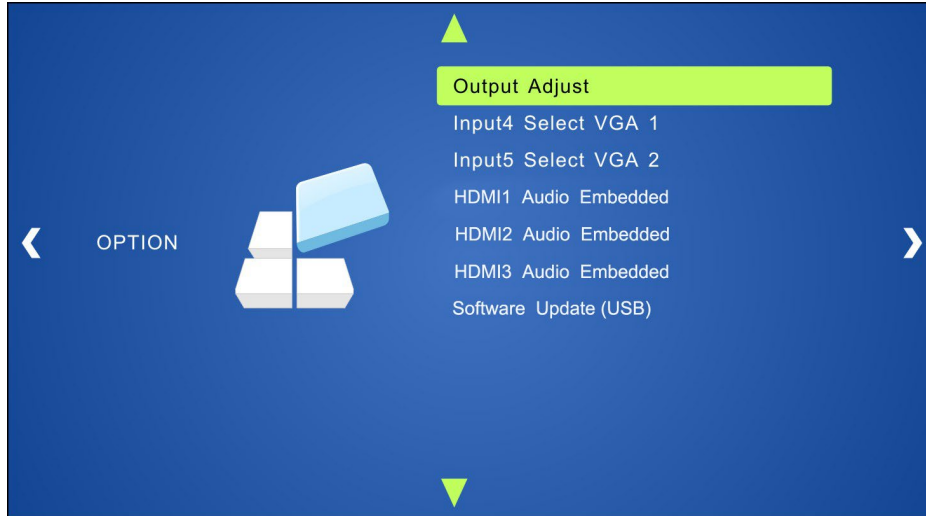

- **Output Adjust:** Adjust output image position (X: horizontal direction and Y: vertical direction) and ratio aspect (width and height).
- **Input5 Select:** Select video source format for VGA input, includes AV 1 (C-video signal), VGA 1 (VGA signal) and YPbPr 1 (Component video signal). Use ENTER button to select the desired source format.
- **Input6 Select:** Select video source for VGA input, includes AV 2 (C-video signal), VGA 2 (VGA signal) and YPbPr 2 (Component video signal). Use ENTER button to select the desired source format. For INPUT5 and INPUT6, when change for new format signal:
 1. Please select a format through this menu (the signal format changed while the video source is still the same).
 2. Switch off the present signal channel (e.g., switch to another channel).
 3. Switch to channel INPUT5/INPUT6 again.
- **HDMI1 Audio Select:** Switch between Embedded and Line to choose the desired audio output port for HDMI1.
- **HDMI2 Audio Select:** Switch between Embedded and Line to choose the desired audio output port for HDMI2.
- **HDMI3 Audio Select:** Switch between Embedded and Line to choose the desired audio output port for HDMI3.
- **HDMI4 Audio Select:** Switch between Embedded and Line to choose the desired audio output port for HDMI3.
- **Software Update (USB):** Insert the USB memory stick with updated firmware file to USB port of DXP-62 to update the software.

Picture

Including Picture Mode, Color Temperature, Aspect Ratio, Noise Reduction, Screen and Color Range. Please check the picture below:

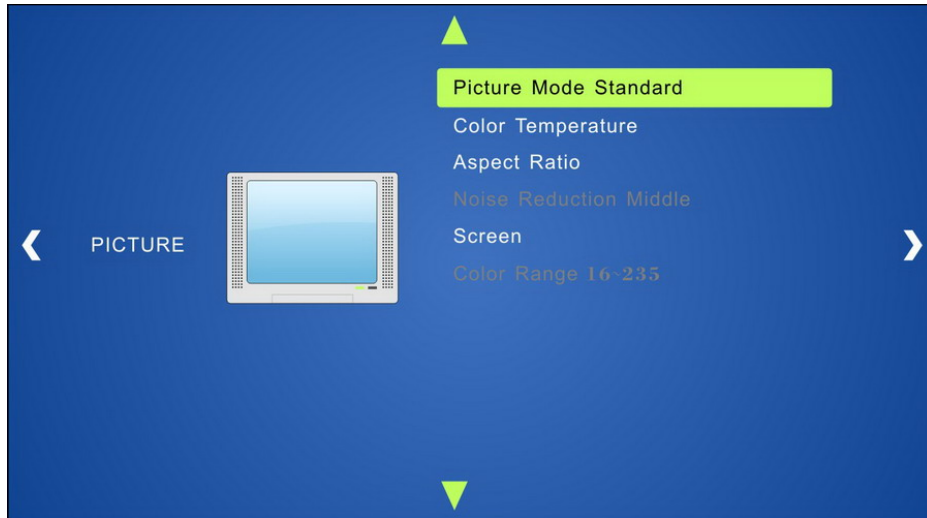

- **Picture Mode:** Includes Dynamic, Standard, Mild, and User. And only in User mode, it is able to set the image contrast and brightness.
- **Color Temperature:** Includes Cool, Medium, Warm and User. And only in User mode, it is able to set values for Red, Green and Blue (RGB).
- **Aspect Ratio:** Includes Native, 4:3, 16:9, Zoom1, Zoom2, Just Scan, Panorama, and Point To Point. VGA format only supports 4:3, 16:9 and Point to Point.
- **Noise Reduction (not for VGA format):** Includes Off, Low, Middle, High and Default.
- **Screen (not for HDMI source):** Includes Auto Adjust, Horizontal, Vertical, Size, and Phase.
- **Color Range (not for VGA format):** Includes 0~255 and 16~235, use ENTER button to select the color range.

Sound

Including Sound Mode, Surround Sound and EQ. Please check the picture below:

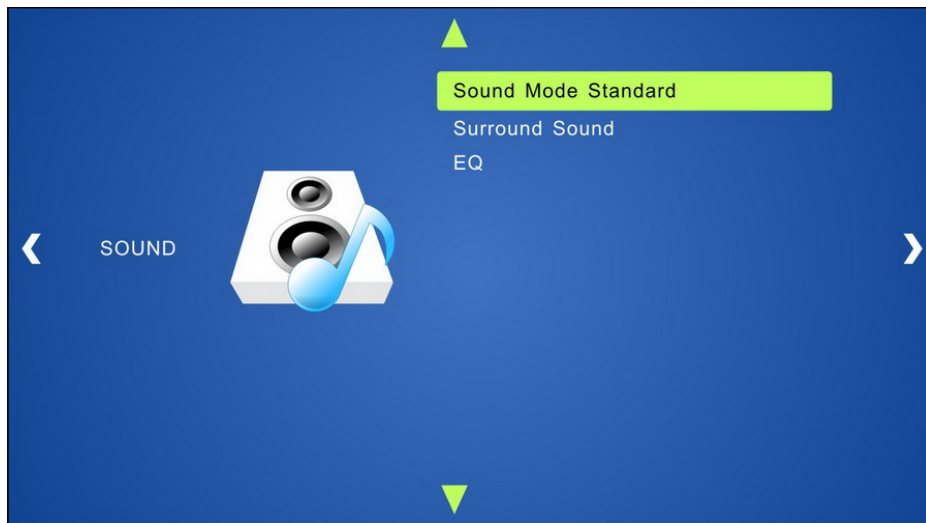

- **Sound Mode:** Includes Standard, Music, Movie, Sports and User. Only User mode supports to set treble and bass.
- **Surround Sound:** Includes Off, Surround and SRS Trusurround XT.
- **EQ:** To adjust the sound balance.

Setup

Including OSD Language, Blending, HDMI CEC and OSD Duration. Please check the picture below:

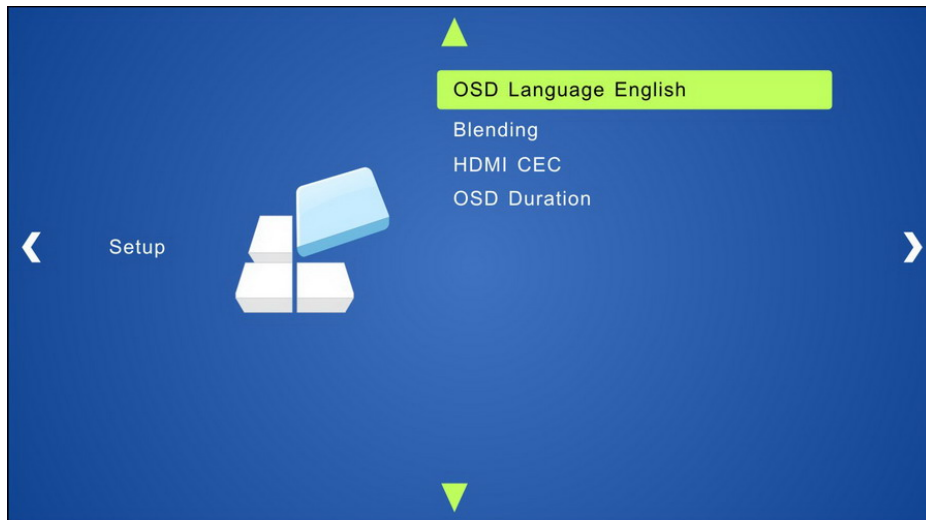

- **OSD Language:** Supports 14 languages, including English (default), Chinese etc.
- **Blending:** Includes Low, Middle, High and Off. Use ENTER button to select.
- **HDMI CEC:** Enable/disable CEC and auto-standby function. Default: CEC on, STANDBY on.

- **OSD Duration:** Includes 5 s, 10 s, 15 s and Off. “s” is for Second.

CEC Function

Supports CEC and CEC standby functions, and can be enabled/disabled through RS232 commands or OSD menu. If the HDMI source device supports CEC and its CEC is on, and when the DXP-62 enter in standby/startup mode, then the source device will automatically enter in standby/startup mode.

And due to CEC function, user can control HDMI source device with basic operations (play, pause, fast forward, fast reverse, menu etc.). So user is able to control the DXP-62 and HDMI source device via the IR remote of the DXP-62.

Serial commands for CEC function: “!CEC1<cr>” (enable CEC) and “!CEC0<cr>” (disable CEC).

The working status related to CEC and STANDBY is showed as below:

Situation	Working Status
CEC: on, Standby: on	Press STANDBY button on IR remote, the DXP-62 enters in standby mode, so do all HDMI source devices. Press STANDBY button again on IR remote, the DXP-62 exits standby mode, only the HDMI source device switched to starts working.
CEC: on, Standby: off	Press STANDBY button on IR remote, DXP-62 enters in standby mode, HDMI 1~3 source devices keep on.
CEC: on	Use CEC function buttons, ▲, ▼, ◀, ▶ and OK buttons on IR remote to control HDMI source devices, include play, pause, fast forward, fast reverse and operations in menu.
CEC: off	Unable to control HDMI source devices through IR remote.

RS232 Control

Operation

As RS232 can be transmitted bi-directionally between the DXP-62 and the HDMI twisted pair PoH receiver, so it is able to control a third party RS232 device from local or control the DXP-62 from remote.

Set the **baud rate** of the DXP-62 via **OSD Menu** to match the controlled third party device as applicable.

***Note: A 200msec delay/spacing is recommended between RS232 command sent to DXP-62.**

RS232 Communication Commands

Communication Protocol: RS232 Communication Protocol

Baud Rate: 9600	Data Bit: 8	Stop Bit: 1	Parity Bit: None
Command	Function	Feedback	Feedback Example
Switch Commands			
!IN01<cr>	Switch to HDMI 1 input	~IN01<cr>	Switch to HDMI 1
!IN02<cr>	Switch to HDMI 2 input	~IN02<cr>	Switch to HDMI 2
!IN03<cr>	Switch to HDMI 3 input	~IN03<cr>	Switch to HDMI 3

Baud Rate: 9600	Data Bit: 8	Stop Bit: 1	Parity Bit: None
Command	Function	Feedback	Feedback Example
!IN04<cr>	Switch to HDMI 4 input	~IN04<cr>	Switch to HDMI 4
!IN05<cr>	Switch to VGA 1/YPbPr 1/AV 1 input	~IN05<cr>	Switch to VGA 1/YPbPr 1/AV 1
!IN06<cr>	Switch to VGA 2/YPbPr 2/AV 2 input	~IN06<cr>	Switch to VGA 2/YPbPr 2/AV 2
!VG1V<cr>	Select VGA 1 for INPUT 5	~VG1V<cr>	Input 5 Set & Switch to VGA 1
!VG1Y<cr>	Select YPbPr 1 for INPUT 5	~VG1Y<cr>	Input 5 Set & Switch to YPbPr 1
!VG1C<cr>	Select AV 1 for INPUT 5	~VG1C<cr>	Input 5 Set & Switch to AV 1
!VG2V<cr>	Select VGA 2 for INPUT 6	~VG2V<cr>	Input 6 Set & Switch to VGA 2
!VG2Y<cr>	Select YPbPr 2 for INPUT 6	~VG2Y<cr>	Input 6 Set & Switch to YPbPr 2
!VG2C<cr>	Select AV 2 for INPUT 6	~VG2C<cr>	Input 6 Set & Switch to AV 2
!ASW1<cr>	Enable auto-switching	~ASW1<cr>	Auto Switching
!ASW0<cr>	Disable auto-switching	~ASW0<cr>	Manual Switching
Audio Commands			
!ALM1<cr>	MUTE line audio	~ALM1<cr>	LINE Mute
!ALM0<cr>	UnMute line audio	~ALM0<cr>	LINE Unmute
!LNUP<cr>	Line audio volume up	~LNUP xx<cr> (xx=00~60)	LINE Volume: xx (xx=00~60)
!LNDN<cr>	Line audio volume down	~LNDN xx<cr> (xx=00~60)	LINE Volume: xx (xx=00~60)
!LNxx<cr>	Set Line volume	~LNxx<cr> (xx=00~60)	Line Volume: xx (xx=00~60)
!ABM1<cr>	Mute LINE audio & MIC audio	~ABM1<cr>	LINE Mute
			MIC Mute
!ALM0<cr>	Unmute LINE audio & MIC audio	~ALM0<cr>	LINE Unmute
			MIC Unmute
!AMM1<cr>	Mute MIC audio	~AMM1<cr>	MIC Mute
!AMM0<cr>	Unmute MIC audio	~AMM0<cr>	MIC Unmute
!EMP1<cr>	Enable Mic precedence	~EMP1<cr>	Mic precedence: enable
!EMP0<cr>	Disable Mic precedence	~EMP0<cr>	Mic precedence: disable
?EMPS<CR>	Check Mic precedence status	~EMPS x<CR> x=1,2(1=enable, 2=disable)	Mic precedence: XXXX (XXXX=enable / disable)
!MCUP<cr>	MIC volume up	~MCUP xx<cr> xx=00~60	MIC Volume: xx (xx=00~60)

Baud Rate: 9600	Data Bit: 8	Stop Bit: 1	Parity Bit: None
Command	Function	Feedback	Feedback Example
!MCDN<cr>	MIC volume down	~MCDN xx<cr> xx=00~60	MIC Volume: xx (xx=00~60)
!MCxx<cr>	Set MIC volume	~MCxx<cr> xx=00~60	MIC Volume: xx (xx=00~60)
!H1A1<cr>	Choose embedded audio as HDMI 1 audio input	~H1A1<cr>	HDMI 1 Audio from Embedded
!H1A0<cr>	Choose external audio as HDMI 1 audio input	~!H1A0<cr>	HDMI 1 Audio from LINE
!H2A1<cr>	Choose embedded audio as HDMI 2 audio input	~H2A1<cr>	HDMI 2 Audio from Embedded
!H2A0<cr>	Choose external audio as HDMI 2 audio input	~H2A0<cr>	HDMI 2 Audio from LINE
Resolution Commands			
!RS04<cr>	Change the resolution to 1360X768 HD	~RS04<cr>	Resolution: 1360x768
!RS01<cr>	Change the resolution to 1024X768 XGA	~RS01<cr>	Resolution: 1024x768
!RS02<cr>	Change the resolution to 1280X720 720P	~RS02<cr>	Resolution: 1280x720
!RS03<cr>	Change the resolution to 1280X800 WXGA	~RS03<cr>	Resolution: 1280x800
!RS06<cr>	Change the resolution to 1920X1080 1080P	~RS06<cr>	Resolution: 1920x1080
!RS07<cr>	Change the resolution to 1920X1200 WUXGA	~RS07<cr>	Resolution: 1920x1200
!RS05<cr>	Change the resolution to 1600X1200 UXGA	~RS05<cr>	Resolution: 1600x1200
Setup Commands			
!LCK1<cr>	Lock the front panel buttons	~LCK1<cr>	Front Panel lock
!LCK0<cr>	Unlock the front panel buttons	~LCK0<cr>	Front Panel Unlock
!BTxx<cr>	Set the brightness to xx.	~BTxx<cr> xx=00~99	Brightness: xx (xx=00~99)
!CNxx<cr>	Set the contrast to xx.	~CNxx<cr> xx=00~99	Contrast: xx (xx=00~99)
!STxx<cr>	Set the saturation to xx.	~STxx<cr> xx=00~99	Saturation: xx (xx=00~99)
!SPxx<cr>	Set the sharpness to xx.	~SPxx<cr> xx=00~99	Sharpness: xx (xx=00~99)
!CT##<cr>	Adjust the color temperature	~CT## xx<cr> xx=01~04(01=cool, 02=medium, 03=warm, 04=user)	Color Temperature: xx (xx= Cool/ Medium/ Warm/ User.)
!AR##<cr>	Set the aspect ratio	~AR## xx <cr> xx=01~07(01=16:9; 02=4:3; 03=auto; 04=panorama; 05=justscan; 06=zoom1; 07=zoom2,when the input source is VGA format, XX can only be 4:3, 16:9 or Panorama)	Aspect Ratio: xx (xx= 16:9/ 4:3/ (auto/ panorama/ justscan/ zoom1/ zoom2, when the input source is VGA format, xx can only be 4:3, 16:9 or Panorama)

Baud Rate: 9600	Data Bit: 8	Stop Bit: 1	Parity Bit: None
Command	Function	Feedback	Feedback Example
!PM##<cr>	Set the picture mode	~PM## xx <cr> xx=01~04(01=dynamic; 02=standard; 03=mild; 04=user)	Picture Mode: xx (xx= dynamic/ standard/ mild/ user)
!SM##<cr>	Set SM audio mode	~SM## xx <cr> xx=01~05(01=standard; 02=music; 03=movie; 04=sports; 05=user)	Sound Mode: xx (xx= standard/ music/ movie/ sports/ user)
!FRZ1<cr>	Freeze output image	~FRZ1<cr>	Freeze: enable
!FRZ0<cr>	Cancel the freezing of output image	~FRZ0<cr>	Freeze: disable
!MVI1<cr>	Enable MIC Volume Icon display	~MVI1<cr>	Volume Icon: enable
!MVI0<cr>	Disable MIC Volume Icon display	~MVI0<cr>	Volume Icon: disable
!HEA1<cr>	Enable HDMI embedded audio output	~HEA1<cr>	Embedded Audio Output: enable
!HEA0<cr>	Disable HDMI embedded audio output	~HEA0<cr>	Embedded Audio Output: disable
!ILM0<cr>	Not display mute icon of LINE audio	~ILM0<cr>	LINE Mute Icon: disable
!ILM1<cr>	Display mute icon of LINE audio	~ILM1<cr>	LINE Mute Icon: enable
!IMM0<cr>	Not display mute icon of MIC audio	~IMM0<cr>	MIC Mute Icon: disable
!IMM1<cr>	Display mute icon of MIC audio	~IMM1<cr>	MIC Mute Icon: enable
!IFZ0<cr>	Display freeze icon	~IFZ0<cr>	Freeze Icon: enable
!IFZ1<cr>	Not display freeze icon	~IFZ1<cr>	Freeze Icon: disable
!ICS0<cr>	Display channel status	~ICS0<cr>	Input Icon: enable
!ICS1<cr>	Not display channel status	~ICS1<cr>	Input Icon: disable
?ICS#<cr>	Check the channel status	~ICS# x<cr> x=1,2(1=enable, 2=disable)	Input Icon: xx
!VGAA<cr>	Auto-adjust the input parameter(VGA only)	~VGAA<cr>	VGA Input Auto
?FIRM<cr>	Check the system version	~FIRM Vx.x.x<cr> Vx.x.x is firmware version	Version Vx.x.x
!MND1<cr>	Enable MIC noise detecting	~MND1<cr>	MIC detect: enable
!MND0<cr>	Disable MIC noise detecting	~MND0<cr>	MIC detect: disable
?MND#<cr>	Check MIC noise detecting statue	~MND# xxxx<cr> , xxxx=MIC detect statue info	MIC detect: XXXX
!HDC1<cr>	HDCP Active	~HDC1<cr>	HDCP Active
!HDC0<cr>	HDCP Manual	~HDC0<cr>	HDCP Manual

Baud Rate: 9600	Data Bit: 8	Stop Bit: 1	Parity Bit: None
Command	Function	Feedback	Feedback Example
!HCO1<cr>	Enable HDCP output	~HCO1<cr>	HDCP ON
!HCO0<cr>	Disable HDCP output	~HCO0<cr>	HDCP OFF
?HDC#<cr>	Inquire HDCP/ Active HDCP	~HDC# xx<cr>, xx=00=HDCP off; xx=11=HDCP on/active;xx=12=HDCP on/manual	HDCP Active
	Inquire HDCP/ Manual HDCP		HDCP Manual
			HDCP OFF/ON
!EDRS<cr>	Restore default EDID	~EDRS<cr>	EDID: initial
!EDBY<cr>	Bypass EDID data from output to input	~EDBY<cr>	EDID: bypass
!EDCS<cr>	Upload custom EDID data to the switcher	~EDCS<cr>	EDID: user
?EDID<cr>	Inquire EDID status	~EDID x<cr> x=1,2,3(1=initial, 2= bypass, 3=user)	EDID: initial EDID: bypass EDID: user
!EDMN<cr>	EDID management, copy the best resolution data of one output to HDMI input	~EDMN xx<cr> xx= the best resolution	EDID manage
			Resolution:1920x1080
!SLM1<cr>	Enable serial control mode 1: control Scaler& far-end from local RS232	~SLM1<cr>	RS232 Mode 1: RS232 Control Scaler& Remote
!SLM2<cr>	Enable serial control mode 2: control Scaler from local RS232 and far-end)	~SLM2<cr>	RS232 Mode 2: RS232 & Remote Control Scaler
!WAKE<cr>	Exit standby mode	~WAKE<cr>	Wake up!
!STBY<cr>	Enter standby mode	~STBY<cr>	Go to standby!
!SFUD<cr>	Software update	~SFUD<cr>	
!FRST<cr>	Reset to factory defaults	~FRST<cr>	Factory Reset
Menu Commands			
!KYOK<cr>	OK for OSD selection	~KYOK<cr>	Key: ok
!KYL<cr>	LEFT button	~KYL<cr>	Key: left
!KYRT<cr>	RIGHT button	~KYRT<cr>	Key: right
!KYUP<cr>	UP button	~KYUP<cr>	Key: up
!KYDN<cr>	DOWN button	~KYDN<cr>	Key: down
!KYM<cr>	MENU button (enter OSD)	~KYM<cr>	OSD: Enter
!KYE#<cr>	EXIT button (exit OSD)	~KYE#<cr>	OSD: Exit

Baud Rate: 9600	Data Bit: 8	Stop Bit: 1	Parity Bit: None
Command	Function	Feedback	Feedback Example
Query Commands			
?VOLL<cr>	Check the volume level	~VOLL xx yy<cr> , xx=Line volume yy=MIC volume (xx=00~66, yy=00-66)	LINE Volume: xx (xx=00~66) MIC Volume: xx (xx=00~66)
?IN##<cr>	Check the input source	~IN## xx<cr> xx=01~06(01=HDMI1, 02=HDMI2, 03=HDMI3,04= HDMI4,05= VGA1,06=VGA2)	Input: xx (xx=HDMI1/ HDMI2/ HDMI3/ HDMI4/VGA1/ VGA2/ YPbPr1/ YPbPr2/ AV1/ AV2)
?RS##<cr>	Check the output resolution	~RS## x<cr> , x=1~7,(1=1920×1200,2=1920×1 080,3=1600×1200,4=1360×768, 5=1280×800,6=1280×720,7=10 24×768)	Resolution: xx (xx=1920×1200/ 1920×1080/ 1600×1200/ 1360×768/ 1280×800/ 1280×720/ 1024×768)
?IM##<cr>	Check the image mode	~IM## x<cr> , x=1~4(1=dynamic,2=standard,3 =mild,4=user)	Picture Mode: xx (xx= Dynamic/ Standard/ Mild/ User)
?AM##<cr>	Check the audio mode	~AM## x<cr> , x=1~5(1=standard,2=music,3=m ovie, 4=sports,5=user)	Sound Mode: xx (xx= Standard/ Music/ Movie/ Sports/ User)
?AR##<cr>	Check the image aspect ratio	~AR## x<cr> , x=1~7(1=16:9,2=4:3,3=auto,4=p anorama, 5=justcan, 6=zoom1, 7=zoom2)	Aspect Ratio: xx (xx= 16:9/ 4:3/ auto/ panorama/ justscan/ zoom1/ zoom2, when the input source is VGA format, xx can only be 4:3, 16:9 or Panorama)
?BT##<cr>	Check the brightness	~BT## xx<cr> , xx=brightness(xx=00~99)	Brightness: xx (xx=00~99)
?CN##<cr>	Check the contrast	~CN## xx<cr> , xx=contrast(xx=00~99)	Contrast: xx (xx=00~99)
?ST##<cr>	Check the saturation	~ST## xx<cr> xx=saturation(xx=00~99)	Saturation: xx (xx=00~99)
?SP##<cr>	Check sharpness	~SP## xx<cr> xx=sharpness(xx=00~99)	Sharpness: xx (xx=00~99)
?CT##<cr>	Check the color temperature	~CT## x<cr> x=1~4(1=cool,2=medium,3=war m,4=user)	Color Temperature: xx (xx= Cool/ Medium/ Warm/ User.)
?IVDS<cr>	Check Volume Icon display status	~IVDS xxxx<cr> xxxx=volume icon info	Volume Icon: xxxx
?DAS#<cr>	Check Digital audio output status	~DAS# x<cr> x=1,2(1=enable,2=disable)	Embedded Audio Output: enable/disable
?AIS#<cr>	Check the audio input sources for HDMI 1, 2,	~AIS# x<cr> , x= 1~2 (1 =HDMI Audio from HDMI port 2=HDMI Audio from LINE port)	HDMI1 Audio from XXXX port HDMI2 Audio from XXXX port
?ALM#<cr>	Check whether the LINE audio is mute or not	~ALM# x<cr> x=1,2(1=line mute, 2=line unmute)	LINE Mute/Unmute
?AMM#<cr>	Check whether the MIC audio is mute or not	~AMM# x<cr> X=1,2(1= MIC mute, 2=MIC	MIC Mute/Unmute

Baud Rate: 9600	Data Bit: 8	Stop Bit: 1	Parity Bit: None
Command	Function	Feedback	Feedback Example
		unmute)	
?FRZ#<cr>	Check the freeze status	~FRZ# x<cr> x=1,2(1=enable, 2=disable)	Freeze: enable/disable
?PLS#<cr>	Check the panel locked status	~PLS# x<cr> x=1,2(1=front panel lock, 2=front panel unlock)	Front Panel Lock/UnLock
?STAT<cr>	Display statues including MIC, LINE audio, Resolution, Output Audio on/off, Manual/ Auto-switching modes	~STAT0 xx yy ii r a s<cr> xx= Line volume(00-99) yy=mic volume(00-99) ii=input channel(01-10) r=resolution(1-7) a=1,2 1= output audio on 2= output audio off s= switch status 1= manual 2= auto	Line Volume:XX
			Mic Volume:XX
			Input:XXXX
			Resolution:XXXX
			Digital Sound Ouput: XXXX
		Switch status: XXXX	
Adjustment Commands			
!PAM1<r>	Enable screen output adjusting	~PAM1<r>	Enter Output Position Adjust
!PAM0<cr>	Disable screen output adjusting	~PAM0<cr>	Exit Output Position Adjust
!PL##<cr>	Move the image to left	~PL##<cr>	Output Position Adjust X xx
!PR##<cr>	Move the image to right	~PR##<cr>	Output Position Adjust X xx
!PU##<cr>	Move the image up	~PU##<cr>	Output Position Adjust Y XX
!PD##<cr>	Move the image down	~PD##<cr>	Output Position Adjust Y xx
!WL##<cr>	Stretch left from left side (increase image width)	~WL##<cr>	Output Width Adjust xx
!WR##<cr>	Pull right from left side (decrease image width)	~WR##<cr>	Output Width Adjust xx
!WU##<cr>	Stretch upwards from top side (increase image height)	~WU##<cr>	Output Height Adjust xx
!WD##<cr>	Stretch downwards from top side (decrease image height)	~WD##<cr>	Output Height Adjust xx
!HMP0<cr>	Turn off HDMI output	~HMP0<cr>	HDMI power off
!HMP1<cr>	Turn on HDMI output	~HMP1<cr>	HDMI power on
!HDB0<cr>	Turn off HDBT output	~HDB0<cr>	HDBT power off
!HDB1<cr>	Turn on HDBT output	~HDB1<cr>	HDBT power on
!HMB1<cr>	Turn on HDMI& HDBT output synchronously	~HMB1<cr>	HDMI HDBT output on

Baud Rate: 9600	Data Bit: 8	Stop Bit: 1	Parity Bit: None
Command	Function	Feedback	Feedback Example
CEC Commands			
!CEC0<cr>	Disable CEC	~CEC0<cr>	HDMI CEC OFF
!CEC1<cr>	Enable CEC	~CEC1<cr>	HDMI CEC ON
!CECP<cr>	Play&pause	~CECP<cr>	CEC cmd: play&pause
!CECS<cr>	Stop	~CECS<cr>	CEC cmd: stop
!CECM<cr>	Menu	~CECM<cr>	CEC cmd: menu
!CERE<cr>	Retreat	~ CERE <cr>	CEC cmd: rev
!CECF<cr>	Forward	~CECF<cr>	CEC cmd: fwd
!CECU<cr>	Up	~CECU<cr>	CEC cmd: up
!CECD<cr>	Down	~CECD<cr>	CEC cmd: down
!CECL<cr>	Left	~CECL<cr>	CEC cmd: left
!CECR<cr>	Right	~CECR<cr>	CEC cmd: right
!CECC<cr>	Conform command	~CECC<cr>	CEC cmd: select
!CECE<cr>	Exit command	~CECE<cr>	CEC cmd: exit

***Note:**

- **Turn on/ off HDCP auto-management by sending serial commands.**
 1. **When HDCP is set to active, whether output source is with HDCP depends on input source. If the input source is with HDCP, so is the output and vice versa.**
 2. **When HDCP is set to Manual, whether the output is with HDCP depends on the statue of HDCP. Turn off HDCP, then the output is without HDCP and vice versa.**
- **Screen output adjusting avails only when the screen output adjusting is on.**
- **CEC commands with grey background avails only when CEC is on.**
- **MIC precedence: In Mute mode, if the MIC noise detecting is on, the device will unmute MIC automatically given the outer noise exceeds the limit of noise detecting. Send Mic precedence to enable, then the device will not be able to change the mute mode no matter how loud the noise is.**

VGA Converting Cable

As VGA source supports YPbPr and C-video source, the compact scaler switcher provides with 2 VGA converting cables to compliant with these signals.

When need to select these signals as input source, please switch to channel INPUT 5 (or INPUT 6), and then set the signal type in OSD. And then switch to other input channel and connect INPUT 5 (or INPUT 6) with corresponding source device. At last, please switch to INPUT5 (or INPUT 6) again.

Connect with Component Video (YPbPr) Source

Operation Examples

- **Via Front Panel Buttons and OSD:** Press **MENU** button on front panel to enter in **OSD**, and then enter in **OPTION** setting menu: set "INPUT 5 Select" to **YPbPr1**, and "INPUT 6 Select" to **YPbPr2**. After setting, press **SOURCE** button on front panel to switch to YPbPr1 or YPbPr2 source.
- **Via RS232 Commands:** Send command **!VG1Y<cr>** (or **!VG2Y<cr>**) to switch to YPbPr1 (or YPbPr2) source.

Connecting the VGA converting cable like this:

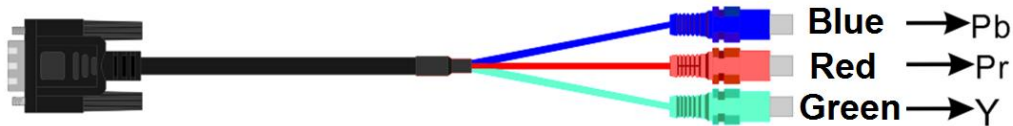

Connect with Composite Video (C-VIDEO) Source

Operation Examples

- **Via Front Panel Buttons and OSD:** Press **MENU** button on front panel to enter in OSD, and then enter in **OPTION** setting menu: set "INPUT 5 Select" to **AV1**, and "INPUT 6 Select" to **AV2**. After setting, press **SOURCE/AUTO** button on front panel to switch to AV1 or AV2 source.
- **Via RS232 Commands:** Send command **!VG1C<cr>** (or **!VG2C<cr>**) to switch to AV1 (or AV2) source.

Connecting the VGA converting cable like this:

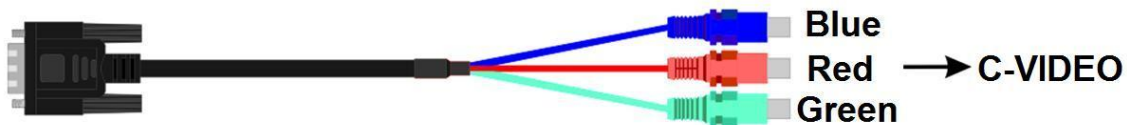

APPENDIX 1

Troubleshooting

For best results, always make certain you have the latest firmware.

Problem	Solution
1. LED is not lit	a. Check to see if Wall supply is plugged into wall outlet. b. Make certain wall outlet has power.
2. No control via COM port	a. Check COM port number in software b. Check COM port baud rate
3. Snowy Output Image	a. Bad quality cable, use higher quality cable c. Check for loose video cables and reconnect
4. No Output Image	a. Check resolution settings match capability of the display. b. Check source is on and input is selected.
5. Increased Static when connecting A/V cables	a. Incorrect grounding, please correct before the DXP-62 is damaged.
6. Control through RS232 commands, but no control from front panel buttons	a. Front panel buttons are locked. Use RS232 command <code>!LCK0<cr></code> to unlock.
7. No Control from front panel buttons or through RS232 port	a. The DXP-62 may be damaged, return to dealer for repair.

- All transmission distances are measured using West Penn cable as per Appendix 3. The transmission distance is defined as the distance between the video source and the display.
- To reduce the interference among the unshielded twisted pairs of wires in UTP cable, you can use shielded STP cables to improve EMI problems, which is worsen in long transmission.

Warning: Do not plug RJ-45 HDBaseT output to non-HDBaseT compliant devices or damage may occur to either product.

APPENDIX 2

Technical Specifications

Model Name	DXP-62
Technical	
Max HDBT Distance	230ft (70m)
Max Resolution	1920x1200 @60Hz
Color Depth	36bit
Bandwidth	HDMI: 1.65Gbps per color, C-Video:150MHz, YPbPr: 170MHz, VGA: 375MHz
RS-232	Max 115kbps
HDMI Inputs	4
VGA/YPbPr/Video Inputs	2
HDMI Outputs	1
HDBaseT Outputs	1 PoH (Video, RS-232, IR)
Audio Inputs	4 Stereo 3 pin 3.81mm Euro / 1 Mic 3 pin 3.81mm Euro
Audio Outputs	1 Stereo 3 pin 3.81mm Euro
Audio Bandwidth	20Hz – 20KHz
RS-232 Ports	1
IR Input Ports	1
IR Output Ports	1
IR Frequency Range	20KHz – 60KHz
HDBaseT Connector	RJ-45 WE/SS 8P8C
RS-232 Connector	Euro Style 3.81mm
IR Connector	3.5mm TRS
HDMI Connector	Type A 19 pin
Power Connector	IEC Male
Mechanical	
Housing	Black Aluminum Enclosure
Dimensions [L x D x H]	8.66" x 5.83" x 1.75" (220 x 148 x 44mm)
Weight	1.477lbs (.67kg)
Mounting	1 RU Rack Mounting
Power supply	12v 16Watt
Operation temperature	0~40°C [32~104°F]
Package Contents	DXP-62, 2 x Mounting Ears, Power Supply, RS232 Cable, 2 x VGA converting cables, 7 x Captive screw connectors, 4 x Screws, 6 x Plastic Cushions

Options	IR Emitter (CA0012-1), DXE-CAT-RX1, DXE-CAT-RX3, DXE-CAT-RX3C, DXE-CAT-RX3-A, DXE-CAT-RX3C-A
---------	--

**Note: Specifications subject to change without notice.*

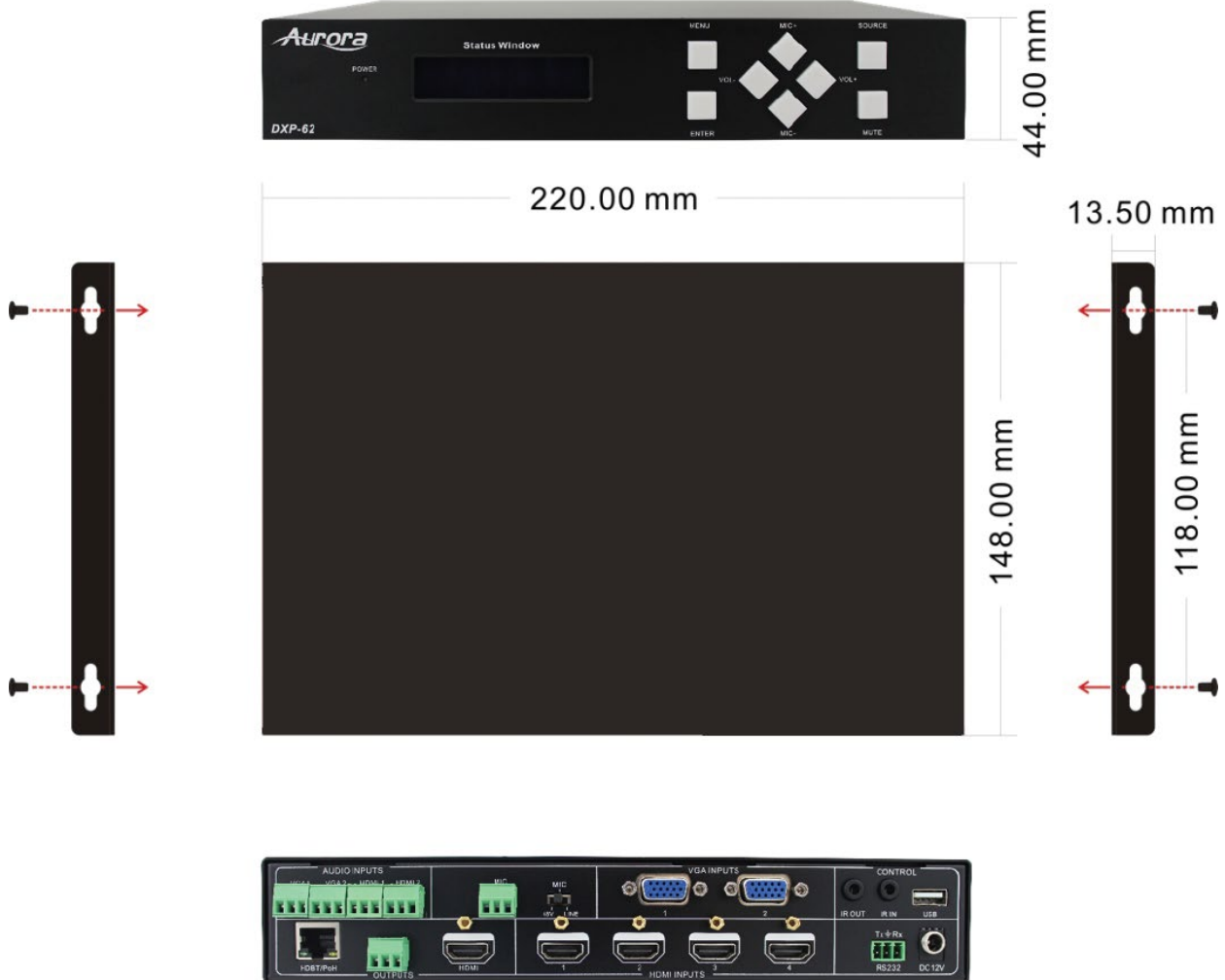

APPENDIX 3

Cabling

Aurora extender products have been tested utilizing shielded cabling. Although our products will work fine without shielded cable it is highly recommended for environmental reasons as the signals are high frequency and can radiate as well as be susceptible to external frequencies and possibly cause noise or disruption in the image. Unshielded cabling will work fine in a conduit, as it will provide the shielding. We have found not all cable is created equal even though they appear similar. This can affect distance and overall performance. Below is a list of cables that have been officially tested with our products by the manufacturer of the cable.

West Penn Wire

CAT 6 Shielded - HDBaseT Certified - Only in Black
4246F – CMR, 254246F – CMP (Plenum)

CAT 6a Shielded HDBaseT Certified - Only in Black
4246AF – CMR, 254246AF – CMP (Plenum)

Both CAT 6 and CAT 6a Shielded Cables utilized a Modular Plug Kit:
90170-BI - Includes: 100 Connectors, 100 Boots, Crimp Tool, External round Crimp Tool, Strip Tool

CAT 6 Unshielded - Colors
4246 – CMR, 254246 - CMP (Plenum)
Connector: 32-6EZP

CAT5e Shielded - Blue or Gray
4245F – CMR, 254245F - CMP (Plenum)
Connector: 32-EZSTP

CAT 5e Unshielded- 12 Colors
4245-CMR, 254245 - CMP (Plenum)
Connectors: 32-EZP

APPENDIX 4

Warranty

Limited 3 Year Warranty

Aurora Multimedia Corporation (“Manufacturer”) warrants that this product is free of defects in both materials and workmanship for a period of 3 years as defined herein for parts and labor from date of purchase. This Limited Warranty covers products purchased in the year of 2009 and after. Motorized mechanical parts (Hard Drives, DVD, etc.), mechanical parts (buttons, doors, etc.), remotes and cables are covered for a period of 1 year. Touch screen displays are covered for 1 year; touch screen overlay components are covered for 90 days. Supplied batteries are not covered by this warranty. During the warranty period, and upon proof of purchase, the product will be repaired or replaced (with same or similar model) at our option without charge for parts or labor for the specified product lifetime warranty period.

This warranty shall not apply if any of the following:

- A. The product has been damaged by negligence, accident, lightning, water, act-of-God or mishandling; or,
- B. The product has not been operated in accordance with procedures specified in operating instructions; or,
- C. The product has been repaired and or altered by other than manufacturer or authorized service center; or,
- D. The product's original serial number has been modified or removed; or,
- E. External equipment other than supplied by manufacturer, in determination of manufacturer, shall have affected the performance, safety or reliability of the product; or,
- F. Part(s) are no longer available for product.

In the event that the product needs repair or replacement during the specified warranty period, product should be shipped back to Manufacturer at Purchaser's expense. Repaired or replaced product shall be returned to Purchaser by standard shipping methods at Manufacturer's discretion. Express shipping will be at the expense of the Purchaser. If Purchaser resides outside the contiguous US, return shipping shall be at Purchaser's expense.

No other warranty, express or implied other than Manufacturer's shall apply.

Manufacturer does not assume any responsibility for consequential damages, expenses or loss of revenue or property, inconvenience or interruption in operation experienced by the customer due to a malfunction of the purchased equipment. No warranty service performed on any product shall extend the applicable warranty period. This warranty does not cover damage to the equipment during shipping and Manufacturer assumes no responsibility for such damage. This product warranty extends to the original purchaser only and will be null and void upon any assignment or transfer.

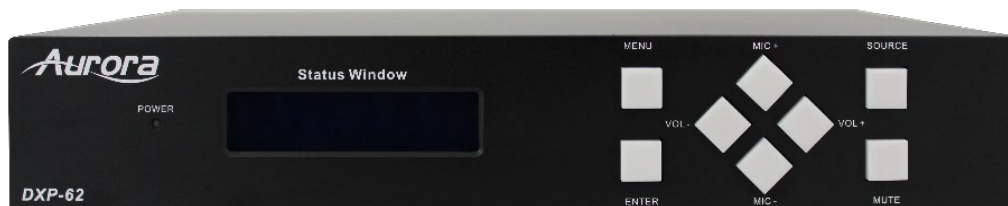

Aurora Multimedia Corporation

205 Commercial Court | Morganville, NJ 07751

Phone: 732-591-5800 | Fax: 732-591-6801