

SkyPanel X

USER MANUAL

November 2024 • 1.1 • English

L5.0049706 • L04248



Disclaimer

Before using the product, be sure to read and understand all respective instructions.

The product is available for commercial customers only.

For product specification changes since this document was published, refer to the latest publications of ARRI data sheets or data books, etc., for the most up-to-date specifications.

Not all products and / or types are available in every country. Please check with an ARRI sales representative for availability and additional information.

The information given in this document is subject to change without notice.

While ARRI endeavors to enhance the quality, reliability and safety of their products, customers agree and acknowledge that the possibility of defects thereof cannot be eliminated entirely. To minimize risk of damage to property or injury (including death) to persons arising from defects in the products, customers must incorporate adequate safety measures in their work with the system and have to heed the stated canonic use.

ARRI or its subsidiaries expressly exclude any liability, warranty, demand or other obligation for any claim, representation, or cause, or action, or whatsoever, express or implied, whether in contract or tort, including negligence, or incorporated in terms and conditions, whether by statute, law or otherwise. In no event shall ARRI or its subsidiaries be liable for or have a remedy for recovery of any special, direct, indirect, incidental, or consequential damages, including, but not limited to lost profits, lost savings, lost revenues or economic loss of any kind or for any claim by third party, downtime, good will, damage to or replacement of equipment or property, any cost or recovering of any material or goods associated with the assembly or use of our products, or any other damages or injury of the persons and so on or under any other legal theory.

Neither ARRI nor its subsidiaries assume any liability for infringement of patents, copyrights or other intellectual property rights of third parties by or arising from the use of ARRI products or any other liability arising from the use of such products. No license, express, implied or otherwise, is granted under any patents, copyrights or other intellectual property right of ARRI or others.

In the case one or all of the foregoing clauses are not allowed by applicable law, the fullest extent permissible clauses by applicable law are validated.

Imprint

© 2024 Arnold & Richter Cine Technik GmbH & Co. Betriebs KG. All rights reserved.

The product contains proprietary information of Arnold & Richter Cine Technik GmbH & Co. Betriebs KG; it is provided under a license agreement containing restrictions on use and disclosure and protected by copyright law. Reverse engineering of the software is prohibited.

No part of this publication may be used for distribution, reproduction, transmission, transcription, storage in a data retrieval system, or translated into any language in any form by any means without the prior written permission of Arnold & Richter Cine Technik GmbH & Co. Betriebs KG.

If you are downloading files from our web pages for your personal use, make sure to check for updated versions.

ARRI cannot take any liability whatsoever for downloaded files, as technical data are subject to change without notice.

Due to continued product development the information in this document may change without notice. The information and intellectual property contained herein is confidential between ARRI and the client and remains the exclusive property of ARRI. If you find any problems in the documentation, please report them to us in writing. ARRI does not warrant that this document is flawless.

Art-Net™ Designed by and Copyright Artistic Licence Holdings Ltd.

ARRI, the ARRI Logo, ARRIMAX, ARRISUN, EB, **UOS**, L-Series, MAX Technology, M-Series, Orbiter, POCKETPAR, Quick Lighting Mount, QLM, True Blue, SkyPanel, SKYPANEL, Stellar and T12 as well as the blue/silver color combination are registered trademarks of Arnold & Richter Cine Technik GmbH & Co. Betriebs KG.

Original version.

Initial Language

The initial language of this user manual is English. User manuals in other languages are translations from English.

In the event of conflict between the respective languages (i.e. if any translation(s) of present document has/have been prepared for convenience or any other purpose), with regards to the meaning or interpretation of a word or an instruction etc., the contents and provisions of the English language version shall prevail.

For Further Assistance

Arnold & Richter Cine Technik GmbH & Co. Betriebs KG

Flintsbacher Str. 1-5

D-83098 Brannenburg

Germany

E-mail: service-lighting@arri.de

Website: <https://www.arri.com/en/technical-service/>

Content

1	About this document	6
1.1	How to Use This Manual	6
1.2	Document Revision History	6
2	About this Product	7
3	Product Layout	10
4	Overview of Control Panel Control Modes	11
5	Overview of DMX Control Modes	12
6	Control Panel: Properties and Use of the Control Modes	13
7	Control Panel: Mode Menu	15
7.1	CCT	15
7.2	HSI	15
7.3	X,Y Coordinates	15
7.4	RGBACL	16
7.5	Gel Selection	16
7.6	Source Matching	16
7.7	Effect	18
7.8	Cue	19
7.9	Favorites	19
8	Control Panel: Main Menu	20
8.1	Light Control Menu	20
8.2	DMX Menu	22
8.3	Network Settings Menu	26
8.4	Wireless Menu	27
8.5	Flash Drive Functions Menu	29
8.6	Display Setup Menu	30
8.7	Fixture Info Menu	32
8.8	Fixture Settings Menu	32
9	Control Panel: User Menu	33
9.1	User Buttons	33
9.2	DMX User Presets	33
9.3	Array Setup	34
10	DMX Control Modes	36
11	Software Tools and Firmware	39
12	Control Panel: Menu Structure	41
13	Error Codes	44

1 About this document

This user manual contains detailed information about the features and functionalities of the device. Please visit the website <http://www.arri.com> to download the operating manual, where applicable, and much more information about this and other ARRI products.

Keep all manuals and all other operating and assembly instructions belonging to the device in a safe place for future reference and possible subsequent owners

For useful information in addition to these manuals please have a look at the [ARRI learn & help](#) section on the [ARRI website](#).

The ARRI Academy courses provide unrivalled insights into the full possibilities of working with ARRI camera systems, lenses, lighting systems and accessories.

Our advanced service training courses are designed to transfer detailed knowledge about how to service and repair all types of ARRI products and give you permanent access to detailed service instructions, special tools and service parts. To learn more, please visit [ARRI academy](#) or contact academy@arri.de.

For more details about the product, please refer to the ARRI website at:

[SkyPanel X product page](#)



Searchkeys:

SkyPanel X, L1.0048487, L1.0048488

[ARRI documentation portal](#)



1.1 How to Use This Manual

All directions are given from an operators point of view. For example, device right side refers to the right side of the device when standing behind the device and operating it in a normal fashion.

Connectors are written in all capital letters, for example "USB connector".

Buttons are written in italic typeface capital letters, for example "*PLAY* button".

Menu paths are written in italic typeface, with menu and home in capital letters, for example "*MENU > Display Orientation > Normal*".

1.2 Document Revision History

Document ID: L5.0049706

Version	Release	Date	Note
1.0		November 2023	First release
1.01	L04196	September 2024	Implementation of LiOS 3.1.1
1.1	L04248	November 2024	Implementation of LiOS 3.1.2

2 About this Product

The SkyPanel X represents the next generation of high-end panel lights – max connectivity and best color/brightness setup. It enables maximum usability for users and rentals while keeping the high-end parameters of ARRI in terms of quality, innovation and reliability.

The SkyPanel X is conceived as a state of the art modular design able to deliver soft and hard lighting. It is optimized for fast, safe and intuitive operation.

The SkyPanel X is an IP 66-rated device. It is protected against powerful water jets (100 liters per minute at 3 m distance with a 2.5 mm nozzle from all directions). This must be clear cold water to avoid corrosion and other material degradation, and never related to high-pressure jet or steam cleaning, which corresponds to a different rating.

ARRI did not only test the SkyPanel X in its facilities and on the field, but also by an independent lab, the TÜV Süd. The test includes a dust-tight test (IP 6x), a waterproof test (IP x6), an electrical safety check after both tests, plus an overall overview on searching for any trace of water inside of the fixture after all testing is performed.

2.1 Features

Light Field

The SkyPanel X is more versatile than a conventional soft light. It can produce hard and soft light using optical accessories.

Even Light Field

The SkyPanel X soft light produces a homogeneous, single-shadow light field, delivering natural results.

Vibrant Colors, Full Spectrum Lighting

True-to-life color rendition is an outstanding feature of the SkyPanel X. The fully tunable white light of the luminaire can be adjusted for different skin tones, camera sensors and mixed light environments. Full gamut color mixing enables the rendition of all color shades. The extensive gel library offers a wide range of familiar colors at the user's fingertips.

Cool Light Beam

The SkyPanel X does not emit any infrared or UV radiation and thus does not forward heat, making actors feel comfortable in the light beam.

Weatherproof

The SkyPanel X is a weatherproof luminaire. It fulfills protection class IP 66.

Multi Unit Control

Multiple devices can be connected in a network via RJ45 wiring. They can be configured as arrays of maximum three devices per array. The array acts as one virtual device and can be controlled via one control panel.

2.2 Properties

Accessory Holder

Optical accessories are placed on the front of the device and secured by two retaining clips. The S60 adapter allows the use of optical accessories for the SkyPanel S60-C.

Yoke

Different yokes are available for the SkyPanel X. The manual yoke made of aluminum is stable and lightweight. The Modular Yoke is designed to carry two or three devices in an array setup.

The two quick-release latches on both sides of the SkyPanel X allow for quick mounting and removing of the yoke or other mounting accessories (like Modular Yoke, twin quick lock or truss adapter) from ARRI. The yoke is included in some sets. It can be ordered separately in case you need a special version.

Tilt-Lock

The high strength tilt-lock provides secure locking. It eliminates movement and slippage and ensures that the SkyPanel X will stay where you put it.

Control

All functions of the SkyPanel X are controllable through DMX, Art-Net or sACN. The device is also fully RDM compatible (with suitable controllers) and is equipped with an RDM feedback channel for reporting all set parameters including system status.

The SkyPanel X is equipped with an integrated CRMX transceiver for wireless control and RDM communication. The integrated Bluetooth 5.0 transceiver interfaces to the ARRI LiCo Bluetooth app.

Control Panel

For location use a control panel for the SkyPanel X is available. The control panel supports control of intensity, color temperature, green-magenta point, hue, saturation and many more parameters. The control panel can be stowed and used on the backside of the device or off the device via a connector cable.





2.3 Control Options

You can control or configure the SkyPanel X with the options listed in the table below:

Option	Control	Configuration	Information
Control Panel	Yes	Yes	Control Panel: Properties and Use of the Control Modes [▶ 13]
DMX	Yes	No	See <i>SkyPanel X DMX Protocol Specification</i> (Download here)
LumenRadio CRMX (wireless DMX)	Yes	No	Wireless Menu [▶ 27]
RDM	No	Yes	RDM [▶ 24]
Art-Net and sACN	Yes	No	Network Settings Menu [▶ 26]
ARRI Lighting Service Manager ALSM	No	Yes	Download ALSM package from the ALSM Website
SkyPanel X Web Portal	No	Yes	Software Tools and Firmware [▶ 39]
Bluetooth	Yes	Yes	Bluetooth [▶ 28]

2.4 Status LED

The status LED on the rear side of the SkyPanel X indicates the status of the device:

Status LED Behavior		Description
	Green / steady	Normal operation
	Green and blue / steady	Normal operation Art-Net, DMX, sACN traffic receiving
	Green and blue / blinking	Normal operation Wireless DMX traffic receiving
	Orange / blinking slow (2 Hz)	Warning, degraded mode
	Red / steady	Error (fail safe mode)

3 Product Layout

Back View

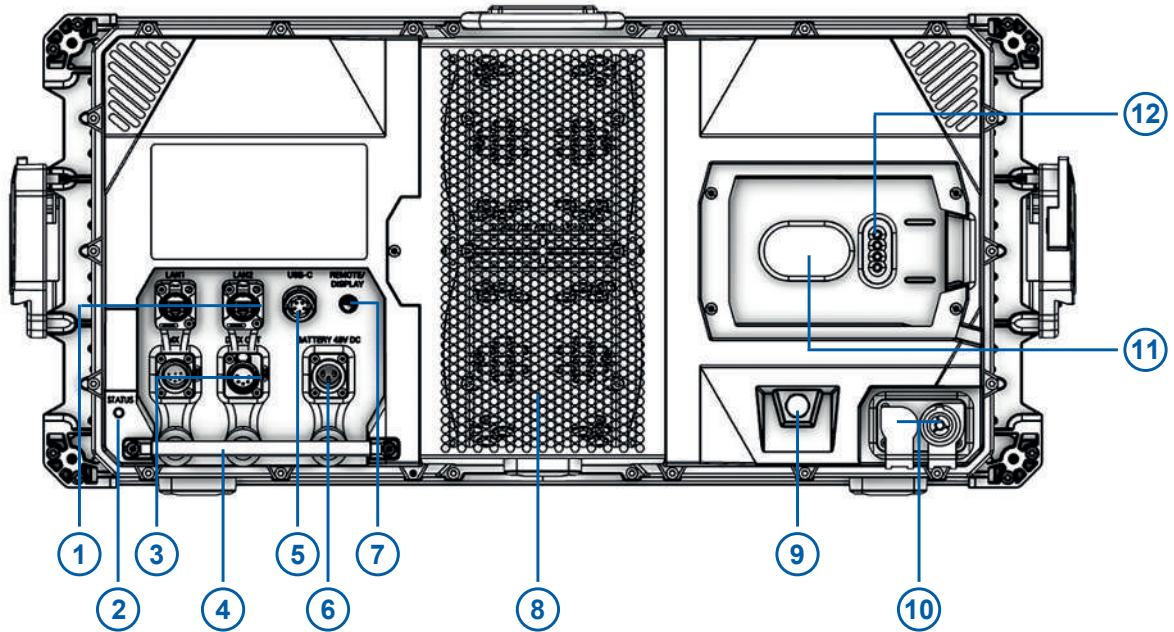
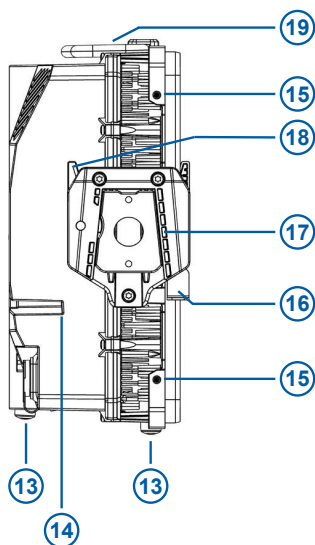

Illustration 1: Back View

- | | | | |
|---|--|----|------------------------------------|
| 1 | LAN 1 / 2 (with rubber caps) | 7 | Remote / display connector |
| 2 | Status LED | 8 | Fan cover |
| 3 | DMX in / thru / out (with rubber caps) | 9 | Climate membrane |
| 4 | Focus handle (not for rigging / safety wiring) | 10 | Mains in / thru (with rubber caps) |
| 5 | USB-C connector (with protective cap) | 11 | Control panel holding magnet |
| 6 | Battery in (with rubber cap) | 12 | Control panel connector pins |

Left View



- | | |
|----|--|
| 13 | Rubber foot (3x) |
| 14 | Drain for control panel recess |
| 15 | Accessories holder (4x) |
| 16 | Retaining clip for accessories (left and right side) |
| 17 | Yoke bracket (left and right side) |
| 18 | Quick release lever |
| 19 | Handle and safety rope attachment for single device |

Illustration 2: Left View (as seen from the front)

4 Overview of Control Panel Control Modes

CCT

The CCT mode provides control of intensity, color temperature and green/magenta point. Additionally the *Extended Color Control* is available to fine tune the beam parameters.

HSI

The HSI mode provides control of intensity, color temperature, green/magenta point, Hue and Saturation.

Additionally the Extended Color Control is available to fine tune the beam parameters.

X,Y Coordinates

X, Y coordinates determines the color displayed by its xy coordinates in the CIE 1931 diagram.

Additionally the Extended Color Control is available to fine tune the beam parameters.

RGBACL (And Calibrated RGBW)

Simple mode for the generation of colored light. It allows control of the overall intensity and the intensities of the colors red, green, blue, amber, cyan and lime. Please note the color space setting.

Additionally the Extended Color Control is available to fine tune the beam parameters.

Gel Selection

The gel mode offers an extensive color filter list. The color temperature of the virtual white light can be set continuously.

Additionally the Extended Color Control is available to fine tune the beam parameters.

Source Matching

Source Matching saves a lot of time when you need a specific illumination. Set the light source which fits best to your demands.

Effects

The effect generator creates 15 different lighting effects on demand. Activate a lighting effect by pressing the encoder and set the parameters as usual.

Some effects support the feature *Change Color*, where you can set the *Effect Color Mode*.

Cue

Cue is a transition between two settings. First set each setting, then set the cue parameters transition time, hold times and direction.

Favorites

You can save up to 246 favorites. A favorite can freely be modified and called up any time. The favorites are saved permanently.

5 Overview of DMX Control Modes

Legacy CCT & RGBW Mode

The legacy CCT & RGBW mode is available with 8 bit and 16 bit resolution. It provides control of intensity, color temperature and green/magenta point, RGBW channels and cross fade from white to color and vice versa.

Additional control channels like fan control, effect selection, light strobe, strobe macros and a control channel to activate DMX presets are present.

Ultimate Modes

The SkyPanel X supports different ultimate modes:

Ultimate (8 bit resolution) and Extended Ultimate (16 bit resolution)

The ultimate modes provide control of intensity, color temperature, green / magenta point and color mode selection (RGB & CCT, HSI & CCT, XY coordinates, raw, not calibrated RGBACL).

Extended Bi Ultimate (16 bit resolution)

The extended bi ultimate mode provides the same features as the ultimate and extended ultimate modes. It provides cross fade from white to color in each color mode.

Additional control channels like fan control, effect selection, light strobe, strobe macros and a control channel to activate DMX presets are present.

Please find more information in the *SkyPanel X DMX Protocol Specification* which is available for free download [here](#).

Multi Zone Modes

The multi zone modes split up each light engine virtually in two zones which can be controlled independently.

- One device with four light engines is split up in 8 zones (8 Zone Mode RGB or CCT & RGB or CCT & RGBACL),
- Two devices set up in an array are split up in 16 zones (16 Zone Mode RGB),
- Three devices set up in an array are split up in 24 zones (24 Zone Mode RGB).

Please find more information in the section Multi Zone Modes [▶ 36].

6 Control Panel: Properties and Use of the Control Modes

This section describes the use of the control modes via the control panel.

Please find a complete overview of the parameters and options of the individual features when controlling the device via DMX or a network protocol in the *SkyPanel X DMX protocol specification*, which is available for free download [here](#).

To Set the Intensity in all Control Modes

The encoder sets the intensity in all modes as the default setting (except *Effect*, *Cue* and *Favorites*).

The current value is shown in large letters on the display when changed. The encoder reacts dynamically: fast turning changes the intensity in large steps, slow turning allows very precise adjustment of the intensity.

Press the Intensity quick button to open the intensity shortcut menu: Change the intensity quickly at fixed intervals (+/- 1%, +/- 10%) or to absolute values (0%, 25%, 50%, 75%, 100%). *Back* leaves the intensity shortcut menu.

6.1 Menu Operation

Layout of the Display



Illustration 3: Control panel display layout

The **status bar** (1) gives information about the mode and status messages (symbols and text).

The area **beam parameters** (2) contains information about the recent lighting parameters (e.g. brightness, color temperature, lighting effects).

The area **quick / user button labels** (3) shows the recent function of the corresponding quick / user button. The upper row shows the function linked to a short press, while the lower row shows the function linked to a long press of the of the quick / user button.

Function and Behavior of the Control Elements



Illustration 4: Control elements of the control panel

Element	Input	Result
Encoder	Turn	Change the value of the selected parameter. Scroll through a list or icons on the display.
	Single press	<ul style="list-style-type: none"> Select element, confirm or change value. Jump one level up. <p>When Intensity is selected: Toggle between recent intensity and blackout.</p>
	Double press	No function. Extended Color Control (ECC): Set the selected parameter on its default value.
	Triple press	No function. Extended Color Control (ECC): Set all parameters to their default values.
	Mode	Short press
	Long press	Save the recent settings as a favorite.
Menu	Short press	Open the Menu .
	Long press	Lock and unlock (> 3 seconds) control panel.
User	Short press	Open the User menu.
	Long press	Open programmer view of user buttons.
Quick Buttons	Short press	Calls up the assigned function of the upper row.
	Long press	Calls up the assigned function of the lower row.

7 Control Panel: Mode Menu

The **Mode** menu contains all modes the SkyPanel X can be set to.

The following modes are available:

- CCT [▶ 15]
- HSI [▶ 15]
- X,Y Coordinates [▶ 15]
- RGBACL [▶ 16]
- Gel Selection [▶ 16]
- Source Matching [▶ 16]
- Effect [▶ 18]
- Cue [▶ 19]
- Favorites [▶ 19]

Use the encoder to select the mode.

7.1 CCT

Select the parameter to set with a quick button:

- *Intensity*
- Color temperature *CCT*
- Green-magenta point *G/M*
- *ECC* calls up the extended color control menu.

Set the value of the selected parameter with the encoder. Press **Mode** long to save all recent settings as a favorite.

7.2 HSI

Select the parameter to set with a quick button:

- *Intensity*
- *Hue*
- *Saturation*
- *ECC* calls up the extended color control menu.
- *More* calls up the menu to set the color temperature *CCT* and the green-magenta point *G/M*.

Set the value of the selected parameter with the encoder. Press **Mode** long to save all recent settings as a favorite.

7.3 X,Y Coordinates

Select the parameter to set with a quick button:

- *Intensity*
- *x Value*
- *y Value*
- *Gamut* calls up the Gamut selection list (Rec 709, Rec 2020, PLASA – RGBW calibrated, ARRI Spectra Gamut, Black Body Curve).
- *ECC* calls up the extended color control menu.

Set the value of the selected parameter with the encoder. Press **Mode** long to save all recent settings as a favorite.

7.4 RGBACL



NOTICE

RGBW calibrated is the Default Mode

You need to deactivate the RGBW calibrated mode to activate RGBACL control and vice versa:

Select the parameter to set with a quick button:

- *Intensity*
- *Red, Green, Blue, Amber, Cyan, Lime* to set the portion of the selected color in the color mix
- *ECC* calls up the extended color control menu.
- *More* calls up the menu to set the color temperature CCT and the green-magenta point G/M. Activate the Calibration Mode with *Cal. to On* to activate the CCT and G/M parameters.

Set the value of the selected parameter with the encoder. Press **Mode** long to save all recent settings as a favorite.

7.5 Gel Selection

Select the parameter to set with a quick button:

- *Intensity*
- *Gel*: Calls up the gel list depending on the
- *Brand*: Toggles between LEE and Rosco
- *Category*: Calls up the category
- *ECC* calls up the extended color control menu.
- *Base CCT* calls up the menu to set the color temperature *CCT* of the virtual white light.
- *No color* removes all gels.

Set the value of the selected parameter with the encoder. Press **Mode** long to save all recent settings as a favorite.

Available filter brands and categories implemented in the gel library:

Rosco	LEE
Color Correction	Color Correction
CalColor	Color Filters
Storaro Selection	600 Series
Roscolux	Cosmetic Filters
	700 Series

7.6 Source Matching

Select the parameter to set with a quick button:

- *Intensity*
- *Category* calls up the list of available categories (see table below).
- *Source* calls up the list of available light sources depending on the category (see table below).
- *ECC* calls up the extended color control menu.

Set the value of the selected parameter with the encoder. Press **Mode** long to save all recent settings as a favorite.

Available categories and light sources in source matching mode:

Category	Light Sources	
Incandescent	Tungsten Bulb Incandescent Halogen Antique Bulb Warm Antique Bulb	Christmas Lights Night Light Infrared Heat Lamp Grow Light
Fluorescent	CFL Soft White CFL Bright White CFL Cool White CFL Daylight	Cool White 1 Cool White 2 Cool White 3 Warm White CFL Blacklight
Discharge	HMI High Pressure Sodium Low Pressure Sodium Mercury Vapor	Metal Halide Ceramic Carbon Arc Xenon
Other	Candle Gas Fire Sun Direct Sun Overcast Sun Blue Hour Mobile Phone Computer Monitor Electroluminescence Blow Torch Road Flare	Amber Caution Green Traffic Light Yellow Traffic Light Red Traffic Light Blue Glow Stick Green Glow Stick Red Glow Stick Yellow Glow Stick Pink Glow Stick Violet Glow Stick

7.7 Effect

Turn and press the encoder to select an effect.

Upon selection the effect menu opens. Depending on the effect different parameters are available.

The parameter *Intensity* is available in every effect. Available parameters of each effect:

Effect	Parameters	Description
Candle	Speed CCT Range	Low flickering of a warm light, slower than fire and less energetic. The light gently fades in CCT and brightness with periods of static behavior in between. It consists of „flutters“ and static periods.
Clouds Passing	Speed Offset Trigger	Slow variations in intensity and CCT that can be offset. The effect is most useful when using many devices that are offset to prevent a simultaneous effect on different devices.
Club Lights	Speed Color Variety (3, 6, 9, 12, 15, 18, 21 or 24 colors)	Random colors that pulse, flash and fade.
Cop Car	Color Combo Flash Pattern	Creates an on-board blue, blue/red, blue/white, blue/red/white, blue/orange, blue/red/orange, red/orange, orange or red flashing effect to mimic a police car, an ambulance or a fire brigade.
Explosion	Trigger Decay Change Color	Creates a bright flash with fast increasing and slow decreasing intensity. Press the quick button „Trigger“ to trigger an explosion.
Fire	Speed CCT Range	Creates a flickering fire effect with randomly changing color temperature.
Fireworks	Speed Colors	Bright flashes of color and have a quick start and fade to zero intensity.
Fluorescent Flicker	Speed Frequency Change Color	Fluorescent color with static periods and then periods of the light flickering on and off.
Lightning	Speed Sequence Trigger Change Color	Creates an on-board flashing lightning effect. Intensity, speed and frequency of flashing can be controlled.
Paparazzi	Speed Flash Type Change Color	Effect that mimics a flash bulb or modern camera flash.
Party Effect	Speed Flash Type	The Party effect calls up the color spectrum or changes the color saturation from full to less and vice versa in an endless loop.
Pulsing	Frequency Duration Change Color	A pulsing or throbbing effect where the color and speed can be set.
Strobe	Speed Change Color	Generates a white or colored strobe effect with adjustable speed.



DANGER

Risk of injury or death through epileptic seizure triggered by a strobe effect.

- ▶ Do not use the strobe effect near stairways, in corridors or near public exits.
- ▶ Mount strobes as high above head height as practicable.
- ▶ Provide advance notice that strobe lighting is in use. Display advisory notices on the set, at the point of ticket sales, on tickets if possible, in the program, and at the entrance(s) to the venue or studio.
- ▶ Avoid extended periods of continuous flashing, particularly at frequencies of 10 to 20 flashes per second. At flash rates below 5 flashes per second, it is estimated that only 5% of flicker-sensitive persons will be at risk of seizure.
- ▶ Make sure that personnel at the venue are trained in the care of a person who is having an epileptic seizure and able to provide care if necessary.
- ▶ If strobes are in use and a person has a seizure, switch the strobes off immediately.

Effect	Parameters	Description
Television	Speed CCT Range	Creates an on-board TV effect. Cool CCT that changes intensity every few seconds.
Welding	Speed Min. Level Change Color	Quick bright flashes with a fast decay.

When you change a parameter of the active effect via DMX or the control panel, the internal effect generator recalculates the values immediately. As a result, the effect may be stepped, stuttering or uneven for a short time. Do not change the parameters while the effect is active if it is important that the effect runs smoothly.

7.8 Cue

The color mode Cue is a transition between two settings.

Available parameters:

- *Status 1*: Set the beam parameters for the first setting by choosing a color mode and its parameters.
- *Status 2*: Set the beam parameters for the second setting by choosing a color mode and its parameters.
- *Hold 1 / Hold 2*: Holding time for each setting.
- *Trans. Time*: Transition time between the two settings.
- *Loop*: Number of transitions between both settings.
- *Bounce*: Toggles between Bounce and Forward.
- *Reset*: Toggles between Reset and Stop. Reset sets the transition back to start while Stop is stopping a running transition.
- *Start*: Starts the transition with the settings.

7.9 Favorites

Favorites are snapshots of the recent beam parameters in the moment you save it. Save a favorite by pressing **Mode** long in the main screen of a control mode.

The favorites are sorted in the order they were saved. Open the control mode *Favorites* and scroll through the list to call up or delete a favorite.

8 Control Panel: Main Menu

The main menu contains several sub menus to set up the device according to your demands:

Light Control Menu [▶ 20]

DMX Menu [▶ 22]

Network Settings Menu [▶ 26]

Wireless Menu [▶ 27]

Flash Drive Functions Menu [▶ 29]

Display Setup Menu [▶ 30]

Fixture Info Menu [▶ 32]

Fixture Settings Menu [▶ 32]

Factory Reset [▶ 32]

Press the *Menu* button to open the *Main Menu*. Choose a sub menu to open the overview of functions available in the respective menu.

8.1 Light Control Menu

8.1.1 Host / Client Mode

When Host / Client mode is *On*, the SkyPanel X acts as a host and controls the client devices via DMX. The client devices will exactly mimic the behavior of the host device.

The devices must be connected to each other via a wired DMX data link. By default the Host / Client mode is not active.

To set the Host / Client Mode

- 1) Open *Light Control > Host / Client Mode*.
- 2) Activate or deactivate the mode with a quick button or with the encoder.

The menu closes upon your selection or automatically after some seconds.



NOTICE

Only one device in the DMX data link may be the host. If more than one device is host, all devices in the DMX data link deactivate the Host / Client mode (*Off*).

8.1.2 Operational Mode

The operational mode determines the interaction of light quality, brightness and operating noise:

- **High CRI Vari Fan:** Optimized for high color quality and temperature regulated cooling,
- **High Output:** High brightness with lower CRI and high fan speed,
- **Standard (default):** High color quality and low noise,

or light optimized for digital ARRI cameras:

- **ARRI ALEXA Standard:** high color quality and low noise,
- **ARRI ALEXA Vari Fan:** optimized for high color quality and temperature regulated cooling, or
- **ARRI ALEXA High Output:** High brightness with lower CRI and high fan speed.

To set the operational mode

- 1) Open *Light Control > Operational Mode*.
- 2) Select the operational mode with a quick button or with the encoder.

The menu closes upon your selection or automatically after some seconds.

8.1.3 Dimming Curve

The SkyPanel X supports four dimming curves. The dimming curve is a global setting. It affects both the intensity control via the control panel or wired DMX, wireless DMX, Art-Net and sACN.

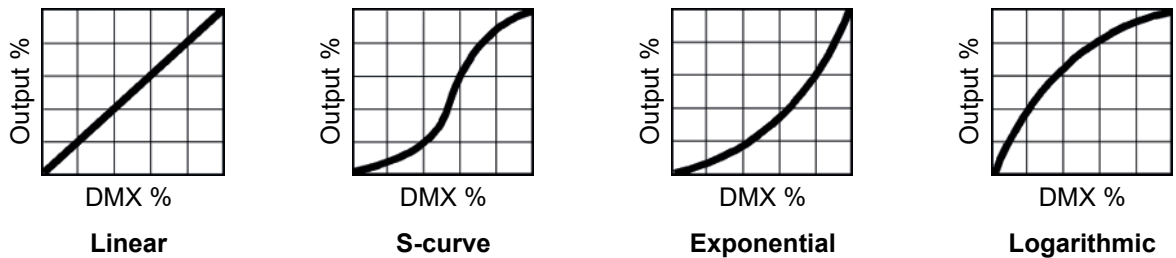

- **Linear:** The intensity changes proportional to the encoder or the channel value.
- **„S“ curve:** The resolution is both high at lower and higher intensity levels and low at intensity levels in between. Use this dimming curve, when you need a high resolution at low and high intensity levels.
- **Exponential (default):** This is the default setting. The resolution is high at lower intensity levels and low at higher intensity levels. Use this dimming curve when you need a high resolution at low intensity levels.
- **Logarithmic:** The resolution is low at lower intensity levels and high at higher intensity levels. Use this dimming curve when you need a high resolution at high intensity levels.

To set the dimming curve

- 1) Open *Light Control > Dimming Curve*.
- 2) Select the dimming curve with a quick button or with the encoder.

The menu closes upon your selection or automatically after some seconds.



NOTICE

The dynamic of an effect using the intensity is very low, when you choose a basic intensity value in a flat area of the dimming curve. Choose a different effect or select another dimming curve to create a more dynamic effect.

8.1.4 Tungsten Mode

The Tungsten Mode mimics the dimming curve and strike on-and-off effect of a traditional tungsten lamp. The CCT warms as the light is dimmed. When the intensity drops to zero quickly there is a short afterglow of warm light. This mode is perfect for mixing the SkyPanel X with tungsten sources or for producing a familiar effect. The default setting is Off.

To activate and deactivate the tungsten mode

- 1) Open *Light Control > Tungsten Mode*.
- 2) Activate or deactivate the mode with a quick button or with the encoder.

The menu closes upon your selection or automatically after some seconds.

8.1.5 Cue Transition Type

The cue transition type determines the fade type between two settings when fading from white light to colored light and vice versa or when fading between two colors. The table below shows the available fade types.

Cue Transition Type	Description
Direct (default setting)	Color 1 > Color 2
Through Black	Color 1 > Black (no light) > Color 2
Through White	Color 1 > White (light, 3.200 K) > Color 2
Over White Point	Color 1 > Above CIE white point > Color 2
Under White Point	Color 1 > Below CIE white point > Color 2

To set the cue transition type

- 1) Open *Light Control > Cue Transition Type*.
- 2) Select the cue transition type with a quick button or with the encoder.

The menu closes upon your selection or automatically after some seconds.

8.1.6 High Speed Mode

The High Speed mode generates flicker-free light for High Speed shootings. The default setting is Off.

To activate and deactivate the high speed mode

- 1) Open *Light Control > High Speed Mode*.
- 2) Activate or deactivate the High Speed mode with a quick button or with the encoder.

The menu closes upon your selection or automatically after some seconds.

8.1.7 RGBACL Color Space

When using RGBACL mode, the SkyPanel X generates colors in a calibrated color space by default.

The calibrated color space Kodak Pro Photo Color Gamut / ESTA standard E1.54 to force the generation of calibrated colors. The color space setting is a global setting. The DMX modes override this setting, it is only for local control.

To activate and deactivate the calibrated RGBACL color space

- 1) Open *Light Control > RGBACL Color Space*.
- 2) Activate or deactivate the RGBACL calibrated mode with a quick button or with the encoder.

The menu closes upon your selection or automatically after some seconds.

8.2 DMX Menu

The SkyPanel X can be controlled via DMX or network protocols. When receiving control data from different sources, the device prioritizes the received data as shown in the table below:

Priority (wireless priority OFF)	Priority (wireless priority ON)
Wired DMX / RDM	Wireless DMX / RDM
Wireless DMX / RDM	Bluetooth
sACN	sACN
Art-Net	Art-Net
Control Panel / Web page via HTTP	Control Panel / Web page via HTTP

8.2.1 DMX Address

When you use the SkyPanel X with wireless or wired DMX in a DMX data network, you must assign a DMX address to the device to be able to control it. The SkyPanel X calculates, dependent on the DMX mode, the required DMX address space. DMX addresses which will not fit in the DMX address space will not be accepted.

To assign a DMX address

- 1) Open *DMX > DMX Address*.
- 2) Select the DMX address with a quick button and / or with the encoder.

The menu closes upon your selection or automatically after some seconds.

8.2.2 DMX Mode

The SkyPanel X offers 10 different DMX modes. Please find a detailed overview of all DMX modes in the document *SkyPanel X DMX Protocol Specification* which is available for free download [here](#).

To set a DMX Mode

- 1) Open *DMX > DMX Mode*.
- 2) Select the DMX mode with the encoder.

The menu closes upon your selection or automatically after some seconds.

8.2.3 DMX Loss Behavior

You can set the behavior of the device when the control signal is lost. The table below shows the available options:

Option	Description
Hold Last Command	This is the default setting. The last received DMX values are used until the device is switched off or valid DMX data is received again.
Black Out	The device douses to 0% intensity immediately.
Hold 2 min and fade out	The last received DMX values are used for 2 minutes. After 2 minutes the device douses to 0% intensity. When valid DMX data is received after less than 2 minutes, these data will be used.

To set the DMX Loss Behavior

- 1) Open *DMX > Loss Behavior*.
- 2) Select the DMX Loss Behavior with a quick button or the encoder.

The menu closes upon your selection or automatically after some seconds.



NOTICE

The setting of the DMX loss behavior is part of a DMX preset. Therefore the setting can change when calling up a DMX preset.

8.2.4 DMX Mode Specification

The DMX Mode Specification is a series of DMX modes. The modes might change from version to version as new features are added.

To select the DMX Mode, if several modes are available:

- 1) Open *DMX > Mode Specification*.
- 2) Select the desired mode with a quick button or the encoder.

The menu closes upon your selection or automatically after some seconds.

8.2.5 DMX Transition Type

The DMX transition type determines the fade type between two DMX settings when fading from white light to colored light and vice versa or when fading between two colors. The table below shows the available fade types.

DMX Transition Type	Description
Direct (default setting)	Color 1 > Color 2
Through Black	Color 1 > Black (no light) > Color 2
Through White	Color 1 > White (light, 3.200 K) > Color 2
Over White Point	Color 1 > Above CIE white point > Color 2
Under White Point	Color 1 > Below CIE white point > Color 2

To set the DMX transition type

- 1) Open *DMX > Transition Type*.
- 2) Select the DMX transition type with a quick button or with the encoder.

The menu closes upon your selection or automatically after some seconds.

8.2.6 DMX Termination

A DMX data link needs to be terminated to suppress reflections of the data signal on an open end of the data link. Signal reflections can trigger unexpected behavior of devices in the data link.

Terminate the DMX data link on the last device in the data link. Terminate the DMX data link on both ends, when you use the RDM functionality. The SkyPanel X provides an internal DMX data link termination.

To terminate the data link

- 1) Open *DMX > Termination*.
- 2) Select the Option *On* (terminated) or *Off* (not terminated, default setting) with a quick button or the encoder.

The menu closes upon your selection or automatically after some seconds.

8.2.7 RDM

The SkyPanel X communicates using RDM (Remote Device Management) in accordance with ESTA's American National Standard E1.20-2006: Entertainment Technology RDM Remote Device Management Over DMX512 Networks.

RDM is a bi-directional communication protocol for use in DMX512 control systems. It is the open standard for DMX512 device configuration and status monitoring.

The RDM protocol allows data packets to be inserted into a DMX512 data stream without affecting existing non-RDM equipment. It allows a console or dedicated RDM controller to send commands to and receive messages from specific devices.

In time critical installations the RDM data packets could cause a DMX signal delay. To avoid unexpected behavior of the devices, you can deactivate the RDM functionality in critical installations.

To activate and deactivate RDM

- 1) Open *DMX > RDM*.
- 2) Select the Option *On* (RDM active, default setting) or *Off* (RDM not active) with a quick button or the encoder.

The menu closes upon your selection or automatically after some seconds.

8.2.8 DMX / RDM Gateway

The DMX/ RDM gateway functionality forwards RDM commands from Art-Net, sACN or CRMX to the XLR DMX ports. This way it is possible to integrate devices which are linked via wired DMX to a wireless DMX or Ethernet control network.

To activate and deactivate the DMX / RDM gateway

- 1) Open *DMX > DMX / RDM Gateway*.
- 2) Select the Option *On* (DMX / RDM Gateway active, default setting) or *Off* (DMX / RDM Gateway not active) with a quick button or the encoder.

The menu closes upon your selection or automatically after some seconds.

8.2.9 Valid Filter

In the default setting, the SkyPanel X checks the integrity of the received DMX data stream. If certain parameters of the data stream change (e.g. number of received DMX channels), the device will display a warning and check the DMX data stream again before it recognizes the data stream as a valid control signal.

If the length of the data stream changes frequently, the check may lead to unexpected behavior of the device. Therefore the function can be deactivated. The SkyPanel X then accepts all received data without further check.

To activate and deactivate the valid filter

- 1) Open *DMX > Valid Filter*.
- 2) Select the Option *On* (Valid Filter active, default setting) or *Off* (Valid Filter not active) with a quick button or the encoder.

The menu closes upon your selection or automatically after some seconds.

8.2.10 DMX Preset Activation Confirmation

This feature gives an optical feedback when a DMX preset is activated. The device flashes in red light for 3 seconds after a DMX preset has been activated.

To activate or deactivate the DMX Preset Activation Confirmation

- 1) Open *DMX > DMX preset Activation Confirmation*.
- 2) Select the Option *On* (Activation Confirmation active) or *Off* (Activation Confirmation not active) with a quick button or the encoder.

The menu closes upon your selection or automatically after some seconds.

8.2.11 DMX Dimmer Smoothing

This feature smooths out changes to the dimming channel and any color parameter channels, in order to avoid stepy behavior. If you want a very fast response, you can switch this setting off.

To activate and deactivate the DMX dimmer smoothing

- 1) Open *DMX > DMX Dimmer Smoothing*.
- 2) Select the Option *On* (DMX dimmer smoothing active, default setting) or *Off* (DMX dimmer smoothing not active) with a quick button or the encoder.

The menu closes upon your selection or automatically after some seconds.

NOTE - DMX Dimmer Smoothing only affects DMX Modes 1 - 5. This setting will have no effect in Multi-Zone DMX modes 6-10."

8.3 Network Settings Menu

The menu *Network Settings* contains various parameters and functions for setting up the SkyPanel X in an ethernet network.

Most parameters and functions are set automatically by the device dependent on the *Network Mode*. In *Manual Network Mode* you can set the parameters

- IP address
- Subnet mask
- Gateway address
- DNS 1, and
- DNS 2

manually.

We recommend the *Manual Network Mode* only in installations where any other Network Mode option will not work. There are some sources of error in *Manual Network Mode* that can lead to unexpected behavior of the device or completely block the installation. Because of this, you should only use the *Manual Network Mode* if you know exactly what you are doing.

8.3.1 Network Mode

The menu *Network Mode* contains all network relevant parameters. Please find a brief overview of the parameters and their options below.

Connection

Accessible in no network mode as it is an information. Shows the status of the network connection:

- **Connection OK:** Network connection established and running.
- **Not connected:** No network found.

IP Address

Accessible in *Manual Network Mode*. Shows the IP address of the device.

Network Mode

Accessible in all network modes. Set the network mode using this menu. The SkyPanel X supports these network modes:

- **DHCP:** The device will automatically receive an IP address from a DHCP server, such as a network router.
- **Art-Net 2.x.x.x:** Provides a simple way to set up the device in an Art-Net custom configured network.
- **Art-Net 10.x.x.x:** Provides a simple way to set up the device in an Art-Net custom configured network.
- **Manual:** Manual setting allows for a static IP address to be set.
- **Auto IP:** Auto IP will automatically generate an IP address.

Subnet Mask

Accessible in *Manual Network Mode*. Shows the Subnet mask of the device.

Art-Net / sACN

Accessible in all network modes. The SkyPanel X supports these Art-Net/sACN modes:

- **Automatic:** The device will automatically detect and switch between Art-Net and sACN signals on the network. If both are present, sACN will be prioritized.
- **Art-Net only:** The device only listens for Art-Net signals.
- **sACN only:** The device only listens for sACN signals.
- **Off:** The device ignores both Art-Net and sACN signal.

Art-Net Universe

Accessible in all network modes. Allows for the additional universes of DMX. Setting can be changed from 0 to 32.767.

Art-Net Net Sub Uni

Accessible in no network mode as it is an information. Shows the Art-Net net sub universe.

sACN Universe

Accessible in all network modes. Allows for the additional universes of DMX over sACN. Setting can be changed from 1 to 63.999.

Art-Net / sACN Merge Mode

Accessible in all network modes. The menu offers the following options:

- **Last Takes Precedence:** The device follows the latest received command from any network controller.
- **Highest Takes Precedence:** The device follows the highest set value from any network controller.

Gateway Address

Accessible in *Manual Network Mode*. Shows the gateway address of the device.

Bonjour

Accessible in all network modes. The SkyPanel X can be found automatically in a network using the *Bonjour* application. You can activate or deactivate *Bonjour* in this menu. You can also set the status via RDM or the Web Portal.

If *Bonjour* is disabled, the fixture cannot be automatically detected by the ARRI Lighting Service Manager (ALSM).

PTP

Accessible in all network modes. Precision Time Protocol (PTP) is used for automatic sorting of the list of available devices during array configuration.

DNS 1 / DNS 2

Accessible in *Manual Network Mode*. Sets the DNS address (Domain Name System) of the device.

Timeserver

Accessible in all network modes. Shows the current network IP address. You can change the IP address as desired.

Logserver

Accessible in all network modes. Shows the current network IP address. You can change the IP address as desired.

MAC Address

Accessible in no network mode as it is an information. Shows the MAC address of the device.

8.4 Wireless Menu

The SkyPanel X is equipped with a wireless DMX transmitter supporting the LumenRadio CRMX, CRMX2 protocol and DMX via Bluetooth in a BLE format.

If there is no DMX traffic received via a wired interface (DMX-512A, ArtNet or sACN) and wireless DMX is activated via the menu, the device can be linked to a wireless DMX transmitter via an RDM discovery command. Once linked successfully, the device processes wireless DMX data and respond to RDM requests only via the wireless link.

The DATA LED on the rear side of the device fades from blue to green followed by a 2 second fade from green to blue as soon as CRMX is active AND CRMX data is received and processed by the device.

If the CRMX Data State is set to *Off*, no wireless DMX and no wireless RDM traffic will be processed.

8.4.1 CRMX

This setting will activate or deactivate the internal LumenRadio CRMX wireless chip.

To activate or deactivate CRMX

- 1) Open *Wireless > CRMX*.
- 2) Select the Option *On* (CRMX active) or *Off* (CRMX not active, default setting) with a quick button or the encoder.

The menu closes upon your selection or automatically after some seconds.

8.4.2 CRMX Link

Activate CRMX to link a SkyPanel X to a CRMX transmitter. The message *Linked* appears on successful linking.

Depending on the CRMX transmitter and the CRMX Mode you need to enter additional information.

To enter additional CRMX information

- 1) Open *Wireless > CRMX Linking Key* and enter the 8 digit CRMX linking key with the encoder. Confirm the setting with *OK*.
- 2) Open *Wireless > CRMX Mode* and select the CRMX mode (CRMX Classic or CRMX2).
- 3) Open *Wireless > CRMX Output* and select the output number (Range A...H (CRMX 2); A, C, E, G (CRMX classic)).

⇒ The device can now be detected by a CRMX transmitter.

To Unlink a SkyPanel X from a Wireless DMX transmitter

- 1) Open *Wireless > CRMX Link*.
- 2) Unlink the device by pressing the quick button or the encoder for three seconds.

Press *Menu* or *Back* to close the menu.



NOTICE

As soon as DMX or RDM traffic is detected via the other interfaces and the wireless priority is set to *Off* (*CRMX > Off*), any wireless DMX or RDM data will be ignored and the SkyPanel X processes the wired DMX/RDM traffic. Set the wireless priority to *On* (*CRMX > On*) to activate CRMX communication again.

8.4.3 Bluetooth

The SkyPanel X supports the LumenRadio Bluetooth Smart (BLE) Technology. Additionally it is equipped with an internal, dedicated Bluetooth 5.0 dongle. It offers longer range and faster response.

You can control the device via the ARRI LiCo Bluetooth app. The app is available free of charge in the App store and the Play store.

Set Bluetooth to *On* for smart devices to take control over the SkyPanel X. *Off* will avoid Bluetooth conflicts with other smart devices.

To activate and deactivate Bluetooth

- 1) Open *Wireless > Bluetooth*.
- 2) Select the *On* (Bluetooth active) or *Off* (Bluetooth not active) with a quick button or the encoder.

The menu closes upon your selection or automatically after some seconds.

You may need to enter a Bluetooth code to establish the connection to a smart device.

To enter a Bluetooth code

- 1) Open *Wireless > Bluetooth Code*.
- 2) Enter the Bluetooth code with the encoder.

The menu closes automatically after entering the code.

8.5 Flash Drive Functions Menu

8.5.1 Favorites

The list of favorites can be saved to a USB-C flash drive. The favorites may be restored or uploaded to a different device.

To save favorites

- 1) Connect a USB-C flash drive to the SkyPanel X.
- 2) Open *Flash Drive Functions > Save Values*.
- 3) All favorites are saved as one file in the root directory of the flash drive.
- 4) Confirm the success message by pushing the encoder.

To load favorites

- 1) Connect a USB-C flash drive to the SkyPanel X.
- 2) Open *Flash Drive Functions > Load Values*.
- 3) Select the desired list of favorites from the list.
- 4) Push the encoder or *OK* to load the list into the device. All favorites stored in the device will be overwritten.
- 5) Confirm the success message by pushing the encoder.

8.5.2 DMX User Presets

The list of DMX user presets can be saved to a USB-C flash drive. They may be restored or uploaded to a different device.

To save DMX user presets

- 1) Connect a USB-C flash drive to the SkyPanel X.
- 2) Open *Flash Drive Functions > Save Presets*.
- 3) All DMX user presets are saved as one file in the root directory of the flash drive.
- 4) Confirm the success message by pushing the encoder.

To load DMX user presets

- 1) Connect a USB-C flash drive to the SkyPanel X.
- 2) Open *Flash Drive Functions > Load Presets*.
- 3) Select the desired list of DMX user presets from the list.
- 4) Push the encoder or *OK* to load the list into the device. All DMX user presets stored in the device will be overwritten.
- 5) Confirm the success message by pushing the encoder.

8.5.3 Fixture Settings

The device settings can be saved to a USB-C flash drive. They may be restored or uploaded to a different device.

To save device settings

- 1) Connect a USB-C flash drive to the SkyPanel X.
- 2) Open *Flash Drive Functions > Save Settings*.
- 3) All device settings are saved as one file in the root directory of the flash drive.
- 4) Confirm the success message by pushing the encoder.

To load device settings

- 1) Connect a USB-C flash drive to the SkyPanel X.
- 2) Open *Flash Drive Functions > Load Settings*.
- 3) Select the desired device settings from the list.
- 4) Push the encoder or *OK* to load the settings into the device. All settings stored in the device will be overwritten.
- 5) Confirm the success message by pushing the encoder.

8.5.4 System

For diagnosis purpose you might be asked to send the error and service log to the ARRI service. The log files can be downloaded to a USB flash drive.

To save the log file

- 1) Connect a USB-C flash drive to the SkyPanel X.
- 2) Open *Flash Drive Functions > Save Log-File*.
- 3) The system log is saved as one file in the root directory of the flash drive.
- 4) Confirm the success message by pushing the encoder.

8.5.5 Firmware

The firmware of the SkyPanel X can be updated using the USB flash drive.

To update the firmware

- 1) Copy the firmware update file to the root directory of the USB flash drive.
- 2) Connect the USB-C flash drive to the SkyPanel X.
- 3) Open *Flash Drive Functions > Update LiOS*.
- 4) Select the firmware update file.
- 5) Follow the dialogue for updating the firmware.

8.6 Display Setup Menu

The menu Display Setup offers different options to set the appearance and behavior of the display.

The following options are available:

- **Auto Adjust** will automatically adjust the display brightness depending on the ambient light around the control panel.
- **Display Backlight** can be set to be always on or to automatically turn off 10 seconds after the last interaction.
- **Display Brightness** is available when *Auto Adjust* is set to *Off*. Set the display brightness with a quick button or the encoder. Press the encoder to confirm the setting.
- **Screen Mode** determines the color pattern of the display: *Dark Mode* is better for low light environments while *Light Mode* is better for bright environments. *Auto Switch* will automatically adjust the screen mode depending on the ambient light around the control panel.
- **Display Orientation** determines if

- the display content will automatically adjust its orientation based on the control panel orientation (*Automatic*), or if
 - the display content will stay normal in relation to the control panel orientation (*Normal*), or if
 - the display content will stay in an upside-down orientation in relation to the control panel orientation (*Upside Down*).
- **Zoomed-in View** *enables* or *disables* the zoomed-in view for value changes.
- The sub menus close upon your selection or automatically after some seconds.

8.7 Fixture Info Menu

The fixture information menu shows all device information in one menu. The following information is available:

Information	Description
Status	Ready (green dot): Device ready, no errors
Data	No activity
Power	Mains power: Powered by AC power source
Errors	No error, or Error list
Light Engine Power Consumption	Recent light engine power consumption in [W]
Temperatures	Shows the recent temperature of: The CPU, the Light engines, the LED driver, and the Mainboard in [°C] or [°F].
Relative Humidity Level	Shows the internal relative humidity level in [%RH]
Light Engine Hours	Working Hours of the light engines (not resettable)
System Hours	Working hours of the device (not resettable)
Fixture Firmware Version	Firmware version used by the device
Fixture Serial Number	Serial number of the device
Control Panel Firmware Version	Firmware version used by the control panel
IP Address	IP address of the device
Art-Net Universe	Art-Net universe the device is set to.
DMX Mode	Recent DMX mode
DMX Address	Recent DMX Address of the device
Loss Behavior	Setting of the DMX loss behavior
CRMX Link	CRMX Link state: Linked or Unlinked
RDM	RDM state: On or Off
DMX/RDM Gateway	Gateway state: On or Off

8.8 Fixture Settings Menu

The fixture settings menu offers some general options:

Language: Set the menu language.

Live view: With *Live View On* every gel or source are presented while scrolling through. *Live View Off* requires a short press on the encoder to present the selected gel or source.

Factory Reset: Performs a factory reset. Please confirm the factory reset, which will also reset favorites and settings.

9 Control Panel: User Menu

9.1 User Buttons

You can assign specific features to the five user buttons on the control panel. You can assign each user button two features. The assigned feature is called up with a short or long press of the user button.

Press **User** long to show the assignment of the user buttons at the bottom of the display in any menu. Press **User** again to hide the assignment.

To program the user buttons

- 1) Open *User > User buttons*.
- 2) Rotate and press the encoder to select one of 10 user buttons.
- 3) Select the desired *category* and the *feature* with the encoder. The selection screen closes automatically upon your selection.
- 4) *Clear* clears the selected user button.
- 5) *Clear all* clears all user buttons.

9.2 DMX User Presets

DMX user presets takes a snapshot of the current DMX settings to store them as one of 10 DMX user presets.

The following settings are stored in a DMX user preset:

- DMX address
- DMX mode
- Footprint
- CRMX state
- Art-Net / sACN state
- Art-Net / sACN merge mode state
- Art-Net universe
- sACN universe
- DMX / RDM gateway state
- DMX loss behavior
- DMX frame filter / valid filter state
- DMX mode specification
- RDM state

To save a DMX user preset

- 1) Open *User > DMX User Presets*.
- 2) Select one DMX user preset with the encoder.
- 3) Press *Store Preset* to store the settings in the selected preset.

View Details calls up a screen to name the DMX user preset or display all settings stored. *Export* saves all DMX user presets to a USB-C flash drive. *Empty Preset* clears the selected DMX user preset.

To activate a DMX user preset

- 1) Open *User > DMX User Presets*.
- 2) Select the DMX user preset with the encoder. Press the encoder to activate the DMX user preset.



NOTICE

Deactivation of Host / Client Mode when loading a DMX user preset.

If Host / Client Mode was active, loading a DMX user preset disables the Host / Client mode as the user expects the new settings.

9.3 Array Setup

About Device Arrays

Two or three SkyPanel X may be grouped into an X22 or X23 array and controlled using a single control panel or DMX profile. We recommend to use the multi yoke to create a mechanically reliable array. The multi yoke is available as an accessory.

In an array the two or three devices must be connected via RJ45 network cables. The firmware detects the devices around using runtime calculations when calculating the device order. The devices are referred as Top, Middle and Bottom device.

It is possible to mix arrays and individual devices in one control network.

In an ethernet network every SkyPanel X searches the network for other SkyPanel X and saves them in an internal list to let them be added to an array. The list updates using events in the network.

In a daisy chain topology the devices are sorted by the order of the cabling. The user needs to daisy chain the devices in a defined way:

- 1) Connect the network cable to LAN 2 of the first device on the data line,
- 2) Connect the network cable to LAN 1 of the next device on the data line,
- 3) Continue connecting LAN 2 of a device with LAN 1 of the next device until your done.

In an array the

- 1) Top device connects via the LAN 2 connector to the
- 2) Middle device LAN 1 connector. The middle device connects via LAN 2 connector to the
- 3) Bottom device LAN 1 connector.

In a network with star topology the device list is sorted by the order of the cabling in each segment.



NOTICE

Order of cabling in an ethernet network

The user decides which device is the first device in a segment via the cabling through the LAN ports. We recommend to use LAN 1 as input and LAN 2 as output to get a good result. The system can handle other cabling as well. In that case the sorting direction of the devices is backwards or mixed up.

Devices in an array work in an own network configuration independently from the current network settings of all SkyPanel X in the network. Devices in an array are controlled in a special way:

The top device acts as a server for all communication and services for itself, the middle and bottom device. The devices in an array are treated as one single device. When a "Refresh" is carried out on the top device, a temporary "Communication Error" may occur on the middle and bottom devices, as the Bonjour service is restarted during the refresh. The warning disappears automatically.

When controlled via a

- **Control panel and web page:** The control panel / webpage of the top device is active, the control panels / web pages of the middle and bottom device are redirected to the top control panel / web page,
- **DMX, Art-Net and sACN:** Only the top device reacts,
- **RDM:** The RDM UID from the top device is taken,
- **CRM Module / Bluetooth:** Only active on top device.



NOTICE

Control Delay between Devices

Devices in an array shall act synchronously when controlled as one device. A maximum delay between devices of 10 msec. (equals camera 25 frames / sec / 180 shutter / 2) is allowed.

The devices in an array check regularly if the array is consistent. If the top device can't detect a middle or bottom device, or if a middle or bottom device can't detect a top device, they continue acting as single devices.

Manual Device Array Setup

- 1) Open *User > Array Setup*. The screen shows an overview of all available devices (individual and array) with number, name, array name and unique array ID.
- 2) Rotate the encoder to scroll through the list.
- 3) Use a quick button or press the encoder to
 - Rename a device:** Choose a name from the list or choose your own name,
 - Add to Array:** Add the device to an automatically generated or new created array. Choose the position (Top [top], second [middle], third [bottom]), or
 - Cancel** the setup process.
- 4) Repeat the procedure until all devices are set up.

Remove does remove the selected device from an array.

Refresh does refresh the screen.

10 DMX Control Modes

Legacy CCT & RGBW Mode

The legacy CCT & RGBW modes behave as the CCT & RGBW DMX modes (modes 1 and 6) of the classic SkyPanel soft light.

Control channels are available for:

- Intensity,
- Color temperature,
- Green / magenta point,
- Cross fade to color,
- Intensities RGBW,
- Fan control, and
- Effects,
- Strobe rate
- Control (DMX presets).

Please find more information in the *SkyPanel X DMX Protocol Specification* which is available for free download [here](#).

Ultimate Modes

The ultimate modes provide a control channel to call up the color modes

- RGB & CCT,
- HSI & CCT,
- XY coordinates, and
- RAW RGBACL (not calibrated).

The options:

- Lighting Effect,
- Gel selection,
- Dimming curve selection,
- Strobe duration,
- Strobe rate,
- Strobe and zone macros,
- Fan mode, and
- DMX preset activation

are available via separate control channels.

Please find more information in the *SkyPanel X DMX Protocol Specification* which is available for free download [here](#).

Multi Zone Modes

The multi zone modes split up each light engine virtually in two zones.

- One device with four light engines splits up in 8 zones (8 Zone Mode RGB or CCT & RGB or CCT & RGBACL),
- Two devices set up in an array split up in 16 zones (16 Zone Mode RGB),
- Three devices set up in an array split up in 24 zones (24 Zone Mode RGB).

In an array the zones are numbered as shown below (seen from the front).

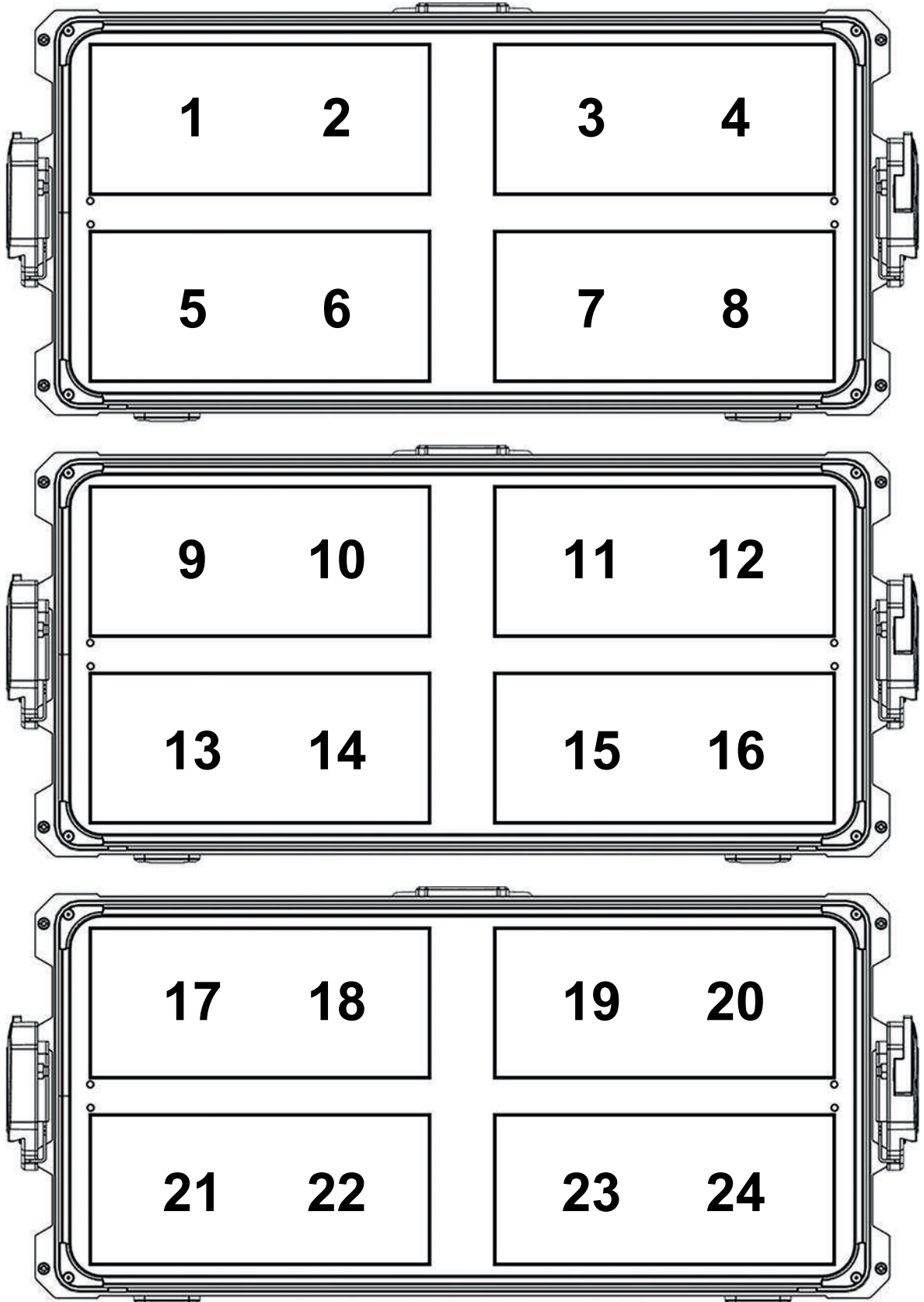

8 Zone Mode RGB

The 8 zone mode RGB controls one device. It provides control of intensity, color temperature, green / magenta point and RGB intensities for each zone.

16 Zone Mode RGB

The 16 zone mode RGB controls two devices in an array. It provides the same features as the 8 zone mode RGB for 16 zones.

24 Zone Mode RGB

The 24 zone mode RGB controls three devices in an array. It provides the same features as the 8 zone mode RGB and the 16 zone mode RGB for 24 zones.

8 Zone Mode CCT & RGB

The 8 zone mode CCT & RGB controls one device. It provides control of master intensity, green / magenta point and dimmer, color temperature, RGB intensities and cross fade from white to color for each zone.

8 Zone Mode CCT & RGBACL

The 8 zone mode CCT & RGBACL controls one device. It provides control of master intensity, green / magenta point and dimmer, color temperature, RGBACL intensities and cross fade from white to color for each zone.

Additional control channels like fan control, effect selection, light strobe, strobe macros and a control channel to activate DMX presets are present for all multi zone modes. These settings are global for all zones.

The DMX smoother is always deactivated in multi zone modes.

11 Software Tools and Firmware

ARRI Lighting Service Manager ALSM

Please find information about the features and the functionality of the ALSM ARRI Lighting Service Manager in the user manual for the ALSM ARRI Lighting Service Manager. You can download it from the [ALSM website](#) free of charge.

Firmware

Please find the latest firmware in the download area of the [LiOS website](#) for free download.



NOTICE

Check regularly on the ARRI SkyPanel X website if a new firmware version is available for the SkyPanel X. For best performance we strongly recommend to use the device with the latest firmware available.

Web Portal

The SkyPanel X provides a web portal accessible via http, when connected to a network. Type in the IP address of the device in your web browser to open the web portal and control nearly every function of the device. The web portal can also be found by using a Bonjour service to discover the device and open the web portal without needing to know the IP address.



NOTICE

Always use the latest version of your web browser. Earlier versions might not be compatible to the web portal of the SkyPanel X.

Avoid access to the web portal during shots or a show. The data exchange with the web portal can lead to delayed reaction time to changes in the control signal or internal calculation routines and to unexpected reactions of the device.

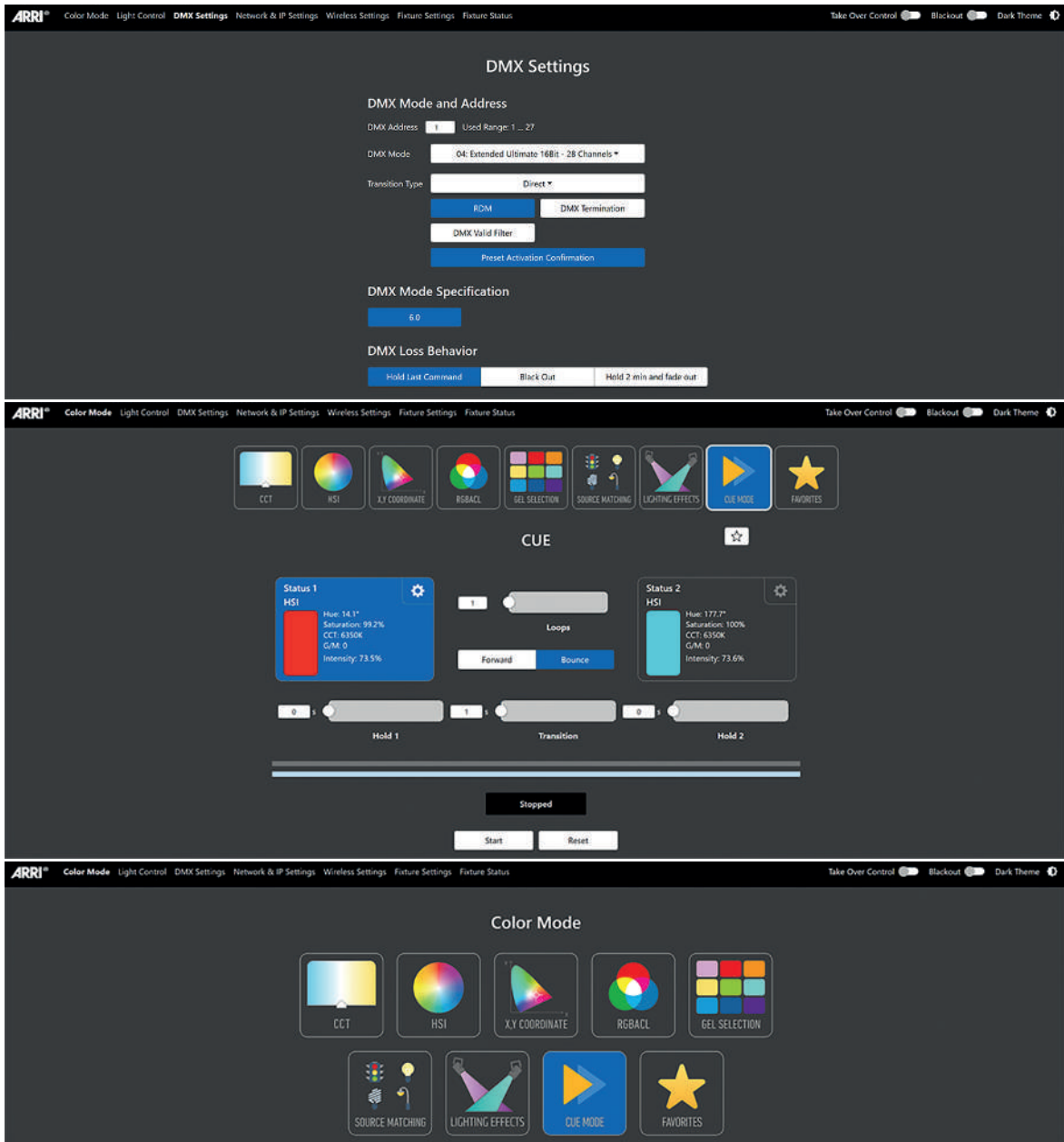

12 Control Panel: Menu Structure

Open the menus **Mode**, **Menu** and **User** with the respective buttons. Turn and push the encoder to select items or set values. Use the user / quick buttons to set values, where applicable. Back closes a menu.

Level 1	Level 2	Level 3	Level 4	Explanation	
Mode	CCT	Intensity		Set the intensity.	
		CCT		Set the color temperature.	
		G/M		Set the green-magenta point.	
		ECC		Calls up the extended color control.	
	HSI	Intensity		Set the intensity.	
		Hue		Set the hue.	
		Saturation		Set the saturation.	
		ECC		Calls up the extended color control.	
		More	CCT	Set the color temperature.	
			G/M	Set the green-magenta point.	
	X,Y Coordinates	Intensity		Set the intensity.	
		X value		Set the color x value.	
		Y value		Set the color y value.	
		Gamut	Rec 709	Set the gamut.	
			Rec 2020		
			PLASA – RGBW Calibrated		
			ARRI Spectra Gamut		
	Black Body Curve				
	ECC		Calls up the extended color control.		
	RGBACL	Intensity		Set the intensity.	
		Red		Set the portion of color in the mix.	
		Green			
		Blue			
		White			
		ECC		Calls up the extended color control.	
		More	Cal. to off / On		Toggle calibration mode.
			CCT		Set the color temperature.
G/M			Set the green-magenta point.		
Gel Selection	Intensity		Set the intensity.		
	Gel		Set the gel.		
	Brand		Toggles between Rosco / LEE.		
	Category		Set the gel set.		
	Base CCT		Set the CCT of the virtual white light.		
	No Color		Removes every gel.		
	ECC		Calls up the extended color control.		

Level 1	Level 2	Level 3	Level 4	Explanation
Mode	Source Matching	Intensity		Set the intensity.
		Category	Incandescent	Set the light source characteristic.
			Fluorescent	
			Discharge	
			Other	
	Source		Set the type of light.	
	ECC		Calls up the extended color control.	
	Effect	Candle ... Welding		Select a lighting effect and set the effect parameters.
	Cue	Status 1		Set scene 1.
		Hold 1		Set holding time scene 1.
		Status 2		Set scene 2.
		Hold 2		Set holding time scene 2.
		Trans. Time		Transition time between scene 1 and scene 2.
		Loop#		Number of loops (1 to infinity).
		Bounce		Toggle Bounce.
		Reset		Reset to start.
		Start		Start cue transition.
Favorites	F.1 ... F.246		Call up favorite #	
	Del. Favorite		Delete selected favorite	
Menu	Light Control	Host/Client Mode	On / Off	Toggles Host / Client mode.
		Operational Mode	High CRI Vari Fan	Set the operational mode.
			High Output	
			Standard	
			ARRI ALEXA Vari Fan	
			ARRI ALEXA High Output	
		ARRI ALEXA Standard		
		Dimming Curve	Exponential	Set the dimming curve.
			Logarithmic	
			Linear	
	"S" Curve			
	Tungsten Mode	On/Off	Toggles Tungsten mode.	
	Cue Transition Type	Direct	Set the cue transition type (the path in the CIE diagram when fading between two colors).	
Through Black				
Through White				
Over White Point				
Under White Point				
High Speed Mode	On/Off	Toggles High Speed Mode.		
RGBACL Color Space	Direct/Calibrated	Set the RGBACL color space.		
DMX	DMX Address ... DMX Dimmer Smoothing		Set and view the DMX related options.	

Level 1	Level 2	Level 3	Level 4	Explanation
Menu	Network Settings	Connection ... MAC Address		Set and view network related options.
	Wireless	CRMX ... Bluetooth Code		Set and view wireless related options.
	Flash Drive Functions	Save Values ... Firmware		Flash Drive related options.
	Display	Auto Adjust ... Zoomed-in View		Display related options.
	Fixture Info	Status ... DMX/RDM Gateway		View device status information.
	Fixture settings	Language		Set menu language.
		Live View	On/Off	Toggles the Live View.
		Factory Reset		Perform a factory reset.
Factory Reset				
User	User Buttons	User Button 1 ... User Button 10		Assign or clear user button functions.
	DMX User Preset	Store Preset		DMX user preset related options.
		View Details		
		Export		
		Empty Preset		
	Array Setup	Add to Array		Array related options.
		Rename		
		Refresh		
		Remove		

13 Error Codes

When the device detects a **warning**, it enters the degraded mode:

- A warning message appears on the control panel,
- All menu functions are still available,
- Operation continues as in normal operation mode,
- Light output continues,
- The device switches back to normal operating mode as soon as the causing fault(s) disappeared.
- If no display is connected, the status LED indicates the type of warning that caused the degraded mode.

When the device detects an **error**, it enters the fail safe mode:

- An error message appears on the control panel,
- Light output is stopped,
- If the power supply of the controller is disturbed, the fixture may switch off, otherwise the main controller is kept alive and an error message is shown on the display.
- If no display is connected, the status LED indicates that the device is in degraded mode. (red status light).

Code	Error or Warning	Error or Warning Message	Remedy
E.001	E	File system not found	Restart the device. If error persists, contact a certified ARRI service center or ARRI service.
E.002	W	Config files missing. Default values are applied	Perform a reset by pressing the reset button (5 s). If warning persists, contact a certified ARRI service center or ARRI service.
E.003	E	LED supply voltage not detected	Restart the device. If error persists, contact a certified ARRI service center or ARRI service.
E.004	E	LED driver not found	
E.005	E	Light engine not found	
E.006	E	LED channel fault	
E.007	E	Calibration fault	
E.008	W	Light engine temperature high	Reduce intensity level to avoid malfunction or failure due to high temperature. Avoid mounting or setup conditions that might block the airflow.
E.009	W	LED driver temperature high	
E.010	W	Mainboard temperature high	
E.011	E	PSU temperature critical	Turn off the device or set intensity to 0 % via control panel or DMX to start cool down process. Restart or increase intensity after a few minutes.
E.012	W	NTC temperature sensor deviation	Reduce intensity level to avoid malfunction or failure due to high temperature. If problem persists, contact a certified ARRI service center or ARRI service.
E.013	W	Fan speed issue	Turn off the device and clean the fans. If problem persists, contact a certified ARRI service center or ARRI service.

Code	Error or Warning	Error or Warning Message	Remedy
E.014	W	DC input voltage low	DC input voltage too low. Increase voltage or switch to mains power supply.
E.015	W	Flash drive power supply not detected	Restart the device. If warning persists, contact a certified ARRI service center or ARRI service.
E.016	W	Flash drive not found	Remove the USB flash drive, wait some seconds and reconnect it. If the problem persists, format to FAT or try a different USB flash drive.
E.017	W	Flash drive read/write not possible	
E.018	W	Factory default values not found	Perform a reset by pressing the reset button (5 s). If warning persists, contact a certified ARRI service center or ARRI service.
E.019	W	DMX signal lost	Check DMX network and cables or enable DMX termination. Manual control via control panel is still possible.
E.020	W	DMX data collision	External gateway or host (Host / Client mode) detected. Device stops acting as gateway or host.
E.021	E	PSU communication lost	Restart the device. If error persists, contact a certified ARRI service center or ARRI service.
E.022	W	LiOS update failed	Repeat firmware update procedure. If warning persists, contact a certified ARRI service center or ARRI service.
E.024	W	Fan power supply not detected	Restart device. If warning persists, contact a certified ARRI service center or ARRI service.
E.029	W	Sensor missing	Please contact a certified ARRI service center or ARRI service.
E.032	W	DC input voltage high	DC input voltage too high. Decrease voltage or switch to mains power supply.
E.034	W	CPU temperature high	Reduce intensity level to avoid malfunction or failure due to high temperature. Avoid mounting or setup conditions that might block the airflow.
E.037	E	LED driver error	Restart device. If error persists, contact a certified ARRI service center or ARRI service.
E.038	W	High system workload	Wait some seconds.
E.039	E	LED driver watchdog elapsed!	
E.040	W	Received DMX data frame too short	Ensure that the used DMX controller supports sending 512 channels. Select a lower DMX start address or change to a mode with a smaller footprint. Deactivate the DMX valid filter.

Code	Error or Warning	Error or Warning Message	Remedy
E.042	W	RTC - Clock not set correctly	Contact certified ARRI service center for battery change. Log files may show incorrect time and date.
E.043	W	CRMX module not found	Restart device. If warning or error persists, contact a certified ARRI service center or ARRI service.
E.044	E	System error	
E.051	W	System watchdog elapsed	
E.053	W	Dim to zero	Dim to zero or clear error state to enable light output.
E.054	E	DMX mode incompatible	The current selected DMX mode is incompatible to the current device array setup. Please choose a compatible DMX mode.
E.055	W	Humidity sensor missing	Restart device. If warning persists, contact a certified ARRI service center or ARRI service.
E.056	W	Take over control active	Take over control active. DMX is blocked therefore. Deactivate "Take Over Control" in the bluetooth app or webpage or clear the warning in the errors list. Alternatively restart the device.
E.057	W	CP temperature high	Control panel temperature high. The control panel back light is switched off 10 s after each user interaction.
E.058	W / E	Array warning / error	A device in the array has a warning / an error. You can try to clear the warning. To analyze the problem, dissolve the array and check all devices separately.
E.059	W	NTC temperature sensor deviation	Reduce intensity level to avoid malfunction or failure due to high temperature. Avoid mounting or setup conditions that might block the airflow.
--	W	Communication error (Message only in CP)	Reconnect control panel and/or restart device. If error persists, contact a certified ARRI service center or ARRI service.
HTTP-Error	W	HTTP-Error (not for CP; only for direct access via any other http client like curl)	Check physical network connection for bad connection and/or network settings.

SKYPANEL[®]  **X**