

7 Series HD SDI+IP Dual Output PTZ Camera

USER MANUAL

VERSION: VCC-7HD-M-12222018



VCC-7HD20S-3SMN

VCC-7HD30S-3SMN

© 2018 Bolin Technology

Contents

IMPORTANT INFORMATION	3
WHAT'S IN THE BOX	6
OVERVIEW	7
FEATURES	7
CAMERA DIAGRAMS	8
REMOTE CONTROLLER	9
SYSTEM CONFIGURATION	10
OBTAIN VIDEO SIGNAL	11
AUDIO IN / OUT	12
SD CARD	12
CAMERA CONTROL METHODS AND SYSTEM CONFIGURATIONS	13
USE THE INFRARED REMOTE CONTROLLER	13
USE RS-232 (VISCA)	13
USE RS-422(VISCA) / RS485 (PELCO P/D)	15
RS422 (VISCA) CONNECTION	15
PELCO P/D KEYBOARD RS485 CONNECTION	17
HOW TO MAKE THE CONNECTION WITH BOLIN PRODUCTS	18
VISCA OVER IP CONTROL	19
VISCA OVER IP NETWORK CONFIGURATION	19
DIP SWITCH SETTINGS	20
ADJUSTING AND SETTING WITH MENUS	22
EXPOSURE MENU	23
WHITE BALANCE MENU	24
PICTURE1 MENU	25
PICTURE2	26
PAN TILT ZOOM MENU	26
SYSTEM MENU	27
UPGRADING MCU FIRMWARE	28
OPERATION USING THE INFRARED REMOTE CONTROLLER	29
PAN/TILT AND ZOOM OPERATION	29
OPERATING MULTIPLE CAMERAS WITH THE INFRARED REMOTE CONTROLLER	30
ADJUSTING THE CAMERA	30
STORING THE CAMERA SETTINGS IN MEMORY — THE PRESETTING FEATURE	31
MENU CONFIGURATION	32
DIMENSION	33

Operating Instructions

Thank you for purchasing our product. If there are any questions, please contact the authorized dealer.

Before operating the unit, please read this manual thoroughly and retain it for future reference.

Copyright

Copyright 2015-2018 Bolin Technology all rights reserved. No part of this manual may be copied, reproduced, translated, or distributed in any form or by any means without prior consent in writing from our company.

Trademark Acknowledgement

 and other Bolin's trademarks and logos are the property of Bolin Technology. Other trademarks, company names and product names contained in this manual are the property of their respective owners.

Trademarks and Registered Trademark Acknowledgement

- Microsoft, Windows, ActiveX, and Internet Explorer are registered trademarks of Microsoft Corporation in the U.S. and/or other countries.
- HDMI, the HDMI logo and High-Definition Multimedia Interface are the trademarks or registered trademarks of HDMI Licensing, LLC in the United States and other countries.
- The Software may contain h.264/AVC video technology, the use of which requires the following notice from MPEG-LA, L.L.C.:

THIS SOFTWARE IS LICENSED UNDER THE AVC PATENT PORTFOLIO LICENSE FOR THE PERSONAL AND NON-COMMERCIAL USE OF A CONSUMER TO (I) ENCODE VIDEO IN COMPLIANCE WITH THE AVC STANDARD ("AVC VIDEO") AND/OR (II) DECODE AVC VIDEO THAT WAS ENCODED BY A CONSUMER ENGAGED IN A PERSONAL AND NON-COMMERCIAL ACTIVITY AND/OR WAS OBTAINED FROM A VIDEO PROVIDER LICENSED TO PROVIDE AVC VIDEO. NO LICENSE IS GRANTED OR SHALL BE IMPLIED FOR ANY OTHER USE. ADDITIONAL INFORMATION MAY BE OBTAINED FROM MPEG LA, L.L.C. SEE <http://www.mpegla.com>.

- HEVC/h.265 Covered by one or more claims of patents listed at patentlist.hevcadvance.com
- HDBaseT is a trademark of the HDBaseT Alliance.
- ONVIF trademarks and logos are to be used per the guidelines established in this and other ONVIF policies and documents including the ONVIF Rules of Membership and the ONVIF Logo Guidelines 1.
- Other trademarks, company names and product names contained in this manual are the property of their respective owners.

IMPORTANT INFORMATION

Legal Notice

Attention:

To ensure account security, please change the password after your first login. You are recommended to set a strong password (no less than eight characters). Password login does not apply to some models that do not need password login.

The contents of this document are subject to change without prior notice. Updates will be added to the new version of this manual. We will readily improve or update the products or procedures described in the manual.

Best effort has been made to verify the integrity and correctness of the contents in this document, but no statement, information, or recommendation in this manual shall constitute formal guarantee of any kind, expressed or implied. We shall not be held responsible for any technical or typographical errors in this manual.

The product appearance shown in this manual is for reference only and may be different from the actual appearance of your device.



This manual is a guide for multiple product models and so it is not intended for any specific product.

In this manual, the illustrations of displayed interface, parameters displayed, drawings and value ranges may vary with models. Please see the actual product for details.

Due to uncertainties such as physical environment, discrepancy may exist between the actual values and reference values provided in this manual.

Use of this document and the subsequent results shall be entirely on the user's own responsibility.

Symbols

Symbol	Description
 WARNING!	Contains important safety instructions and indicates situations that may cause bodily injury.
 CAUTION!	User must be careful and improper operations may cause damage or malfunction of product.
 NOTE!	Indicates useful or supplemental information about the use of product.

Safety Information

WARNING!

Installation and removal of the unit and its accessories must be carried out by qualified personnel. You must read all of the Safety Instructions supplied with your equipment before installation and operation.

Warnings:

- If the product does not work properly, please contact your dealer. Never attempt to disassemble the camera yourself. (We will not assume any responsibility for problems caused by unauthorized repair or maintenance.)
- This installation should be made by a qualified service person and should conform to all the local codes.
- When shipping, the camera should be packed in its original packaging.
- Make sure the power supply voltage is correct before using the camera.
- Do not drop the camera or subject it to physical shock.
- Do not touch sensor modules with fingers. If cleaning is necessary, use a clean cloth with a bit of ethanol and wipe it gently. If the camera will not be used for an extended period of time, put on the lens cap to protect the sensor from dirt.
- Do not aim the camera lens at the strong light such as sun or incandescent lamp. The strong light can cause fatal damage to the camera.

Maintenance Precautions:

- If there is dust on the front glass surface, remove the dust gently using an oil-free brush or a rubber dust blowing ball.
- If there is grease or a dust stain on the front glass surface, clean the glass surface gently from the center outward

using anti-static gloves or an oil-free cloth. If the grease or the stain still cannot be removed, use anti-static gloves or an oil-free cloth dipped with detergent and clean the glass surface gently until it is removed.

- Do not use organic solvents, such as benzene or ethanol when cleaning the front glass surface.

Regulatory Compliance

FCC Part 15

This equipment has been tested and found to comply with the limits for digital device, pursuant to part 15 of the FCC Rules. These limits are designed to provide reasonable protection against harmful interference when the equipment is operated in a commercial environment. This equipment generates, uses, and can radiate radio frequency energy and, if not installed and used in accordance with the instruction manual, may cause harmful interference to radio communications. Operation of this equipment in a residential area is likely to cause harmful interference in which case the user will be required to correct the interference at his own expense.

This product complies with Part 15 of the FCC Rules. Operation is subject to the following two conditions:

This device may not cause harmful interference.

This device must accept any interference received, including interference that may cause undesired operation.



LVD/EMC Directive

This product complies with the European Low Voltage Directive 2006/95/EC and EMC Directive 2004/108/EC.









WEEE Directive—2002/96/EC

The product this manual refers to is covered by the Waste Electrical & Electronic Equipment (WEEE) Directive and must be disposed of in a responsible manner.

WHAT'S IN THE BOX

Note: The camera color may be in white or black per the item that is purchased.

	Camera X 1
	IR Remote Controller X 1 (3V CR2032 Coin Lithium Battery Required)
	Camera Power Adaptor and Power cord X 1
	Bag of Mounting Screws X 1
	RJ45 to RS232 Extension Cable X 1
	RJ45 to RS422 Extension Cable X 1
	User Manual X 1

Accessories (Optional)

	RS232 8 Pin Mini Din to Phoenix Terminal Block
	Wall Mount
	Ceiling Mount

Overview

This user guide is suitable for the following models:

VCC-7HD20S-3SMN

VCC-7HD30S-3SMN

Features

- Resolution: Up to 1080P60, 1080i59.94
- IP Resolution: Up to 1080P60, 1080P30
- Zoom: Optical 20X, 30X
- Image stabilizer(20X) and true WDR 130dB
- Video Output: HDMI, 3G-SDI, IP, CVBS simultaneously
- ± 350 -degree continuous pan, ± 120 -degree continuous tilt
- 128 presets, Speed up to 150 degrees/sec
- Standard mounting and ceiling mounting with E-Flip function
- Control supports RS-232 control, RS-422/485 control, VISCA-over-IP, IP-Onvif*, CGI*, IP control software*, IR Remote Controller
- Presets store camera directions and image parameters. (Up to 6 presets on remote controller or 128 presets via protocol programming.)
- Image parameter setting restore with presets and quick access operation
- IP Protocol RTSP, RTMP for online video streaming.
- Local storage Micro SD card up to 32GB supported.
- Supports Audio input, Audio output with IP streaming.
- Power: DC 12V, PoE+(IEEE802.3at)
- Firmware upgrade via USB2.0 or IP
- *Features to be supported on future firmware release.

Camera Diagrams

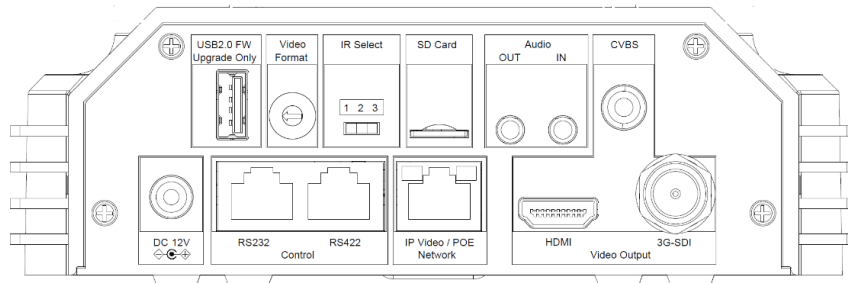

1. **12V DC Power Port**
Connect the supplied DC power adaptor and cord.
2. **USB2.0 Port**
For firmware upgrade only
3. **RS232 Control Port (RJ45)**
RJ45 to RS232 convertor cable is provided.
4. **Video Format Selector**
For video format selection
5. **RS-422 Control Port (RJ45)**
RJ45 to RS422 convertor cable is provided.
6. **IR Remote ID Selector**
Camera ID for IR remote controller
7. **Micro SD Card Port**
8. **IP Network RJ45 Port**
For VISCA over IP control and IP video streaming, with POE+(IEEE802.3at).
9. **Audio Output/Input**
10. **HDMI Port (HDMI 1.4)**
11. **CVBS Video Output**
12. **3G-SDI Video Output**
13. **IR Remote Controller Sensors**
These are sensors to receive commands from infrared remote controller.
14. **Power LED Indicator**
Turns green when the camera is connected to power outlet. When the power is turned on, it takes about 15 to 30 seconds to display the image after LED turns on.
15. **Lens**

This is a 20X/30X magnification optical zoom lens

16. Fix Mounting Holes

For original wall/ceiling mount bracket

17. Tripod mounting holes

18. Bottom DIP Switch

Remote Controller

1. Power

- Power ON the camera to turn the camera in operation status.
- Power OFF the camera to turn the camera in standby status.
- When the camera is powered OFF, the camera turns to the back and would be on standby mode.
- When the camera is powered ON, the camera turns to the front.
- Powering the camera ON/OFF would not restart the camera.

2. Camera ID (Total 3) Selector

3. Preset Position (Total 6) Calling and Setting

4. PAN-TILT

- Pan and Tilt direction control
- HOME: Home position, Resolution reset

5. L/R Direction Set

- Left and right orientation setting

6. ZOOM/FOCUS

- Far
- Near

7. Auto/Manual Focus

8. Back Light

9. Video Format Switching

- You can change the video format by keep pressing the button. (When video format is changed, the camera would restart and the screen turns black for few seconds.)

10. MENU

- On screen menu display ON/OFF

11. Audio Switch

- You can turn the Mic built in the camera Off/ON by pressing the button once.

12. Fast/Slow Zooming Speed Switching

13. White Balance

- Change the White Balance setting by pressing the button.

14. De-Flicker

- When you find the video flicking, press the button once to eliminate the flickers.

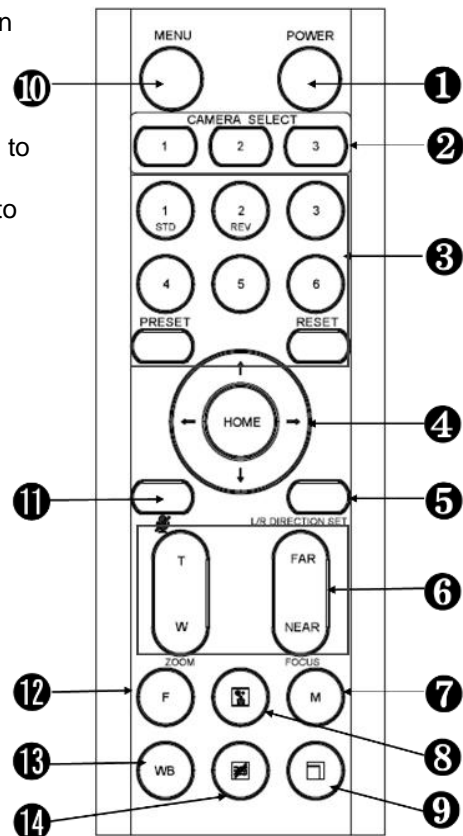

Notes

- 3V CR2032 Coin lithium Battery is not included with the remote controller.
- 3V CR2032 Coin lithium batteries are not re-changeable.

System Configuration

Connection

When the camera is connected to a computer and joystick keyboard with a VISCA cable (cross type, RS-232), you can operate the camera with the computer and the joystick keyboard.

When the camera is connected to a joystick keyboard a control cable (cross type, RS-422/485), you can operate the camera's pan, tilt, zoom with the joystick keyboard.

In this connection configuration, HDMI cable, SDI video cable, data cable, Network cable is required. To obtain these third-party components or accessories, consult the dealer where you bought your camera.

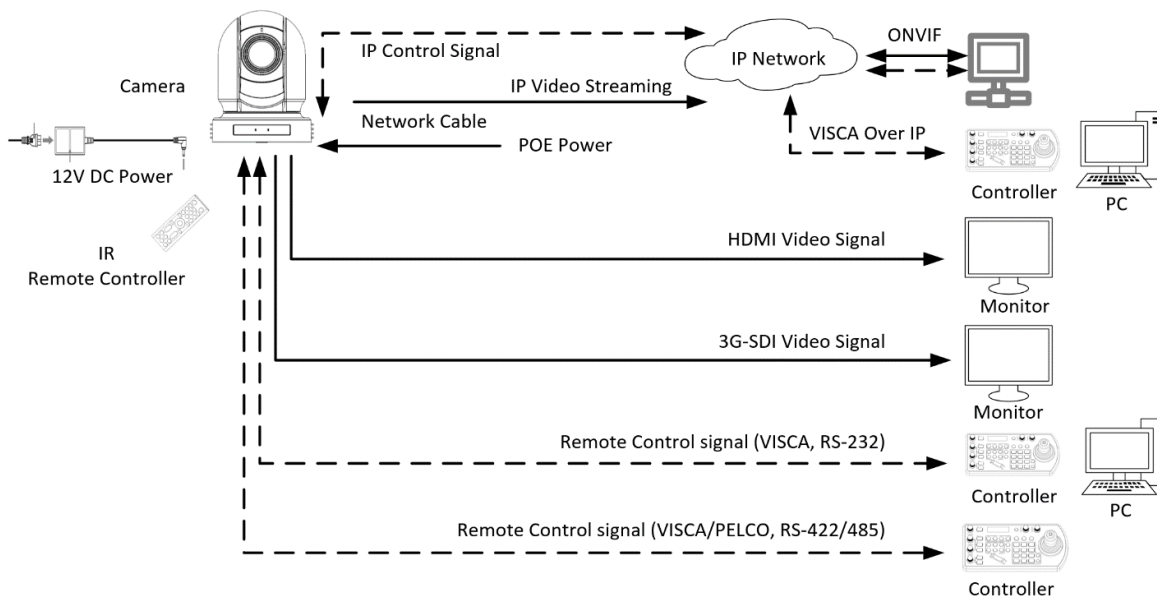

Power

- Use only the DC power adaptor (JEITA type4) supplied with the unit. Do not use any other DC power adaptor.
- If using POE to power the camera, PoE+(IEEE802.3at) is supported
- Ensure that the POE power source has sufficient power budget to power the camera, or some features may not function properly.



Cable Requirements

- Network Cable: 10/100 Mbps Ethernet CAT 5/5E/6 UTP cables are applicable to the ANSI/EIA/TIA-568A/B and ISO/D. Eight wires in the network cable need to be inserted in parallel into the top of the cable connector. The cable connector needs to be crimped in position. When the cable connector is in position, ensure that the metal pieces of the cable connector are parallel to each other and the clamp of the cable connector is intact.
- SDI Cable: For broadcast use, Belden 1694A/5CFB is a suitable cable to transmit broadcast-quality video:

1694A

COAXIAL CABLES

6.44

Precision Video Cable for Analog and Digital
RG-6/U and RG-11/U Type



Description	Part No.	UL NEC/ C(UL) CEC Type	Standard Length		Standard Unit Weight		Conductor (Stranding) Diameter Min. DCR	Nominal Core OD		Shielding Materials Min. DCR	Nominal OD		Nom. Imp. (Ω)	Nominal Capacitance		Nominal Attenuation			
			ft.	m	Lbs.	kg		inch	mm		inch	mm		pF/ft.	pF/m	dB/100 Ft	dB/100m		
RG-6/U Type • 18 AWG Solid .040" Bare Copper Conductor • Duofoil® (100% Coverage) + Tinned Copper Braid Shield (95% Coverage)																			
Gas-Injected Foam HDPE Insulation • PVC Jacket (Available in 10 colors)*																			
SDI/HDV	1694A	NEC	500	152.4	20.5	9.3	18 AWG	180	4.57	Duofoil	275	6.99	75	82%	16.2	53.1	1	2	8
Digital Video		CMR	1000	304.8	45.0	20.5	(solid)			+ 95%							3.6	5	1.5
		CEC	4900	1371.6	202.5	91.9	040"			TD Braid							10	7	2.4
		CMG FT4					BC			2.8k2/M							71.5	1.6	5.2
							6.4k2/M			9.2k2/M							135	2.1	6.9
							21.0k2/M										270	3.0	9.7
																	360	3.4	11.5
																	540	4.3	13.9
																	720	4.9	16.1



For Plenum version of 1694A, see 1695A.
Also available in bundled versions. See 7710A through 7713A.

Conductor:

AWG	Stranding	Material	Nominal Diameter
18	Solid	Bare Copper	0.04 in.

Shield Material

Type	Layer	Material	Coverage
Tape	1	Aluminum / Polyester / Aluminum	100%
Braid	2	Tinned Copper	95%

Nom. Capacitance Conductor to shield	Nom. Inductance	Nom. Char. Impedance
16.2 pF/ft	0.106 μ H/ft	75 Ohm

Obtain Video Signal

The camera can simultaneously have SDI video output and HDMI video output and IP video output.

HDMI HD Video signal

1. Connect the camera to a HD monitor/TV using HDMI cable.
2. Turn on the camera, video will display on the monitor after running initializing.
3. Information of the camera initial setting status will display for 5 seconds.
4. You can set the video format of the camera to the one you want to display.

SDI Video Signal

The camera can simultaneously stream SDI video output with HDMI video output.

1. Connect SDI cable in between the camera your SDI Device/display.
2. You now have SDI video output.
3. SDI video only supports 1080P.

IP Video Signal

The camera can simultaneously stream IP video output and SDI video output and HDMI video output.

1. Connect the camera to the network using Cat5/Cat6 network cable.
2. You need to have a web browser or VMS client software ready for IP video streaming.
3. PELCO address and Baud Rate setting on the camera must be as same as the setting on camera IP WEB interface.
4. To obtain IP video and configure IP video, please refer to Network Camera User Manual Part Two.

CVBS Video Signal

1. Connect CVBS cable in between the camera and your CVBS Device/display.
2. You now have CVBS video output.

Camera Initial setting status Information

Information of the camera initial setting status will display for 5 seconds.

1. Camera PELCO ID for RS-485 control
2. Camera ID for IR Remote Controller
3. IR remote control signal receive current setting
4. Baud Rate current setting
5. Control COMM Port current setting
6. Video format current setting
7. HDMI current setting
8. Model number
9. Firmware version

Camera Status Info Display

PELCO ID	001
IR ID	01
IR-RECEIVE	ON
BAUD RATE	9600
COMM TYPE	422
FORMAT	1080P29.97
HDMI OUT	YUV
MODEL TYPE	----
SV:	V0B1100S36040A004

Audio IN / OUT

- A microphone can be connected to the **Audio IN** port, which feeds audio into the camera
- A speaker can be connected to the **Audio OUT** port, which will output any audio that is captured on the **Audio In** port
- See Manual part 2 for more information about Audio capture

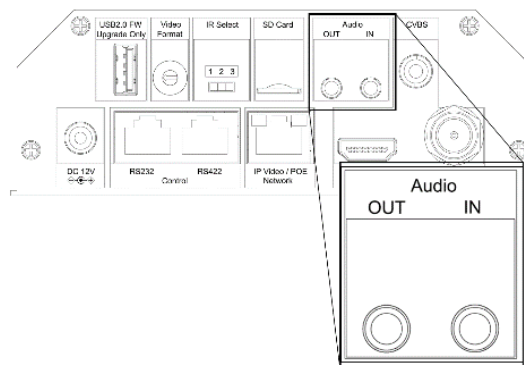

SD Card

Micro SD card can be inserted to the camera for local recording.

- Ensure that the Micro SD card's pins are faced downward (logo faced up)
- Slide the card into the slot, and click into place
- To remove the card, click inward, and it will pop outward and may be removed
- See Manual part 2 for more information regarding SD recording

Currently, the following Micro SD cards are supported:

Brand	Size	Format	Type	Class	Transfer Bus
Kingston	16GB	exFAT	SDHC	10	IU1
Kingston	32GB	FAT32	SDHC	10	IU1
Kingston	32GB	exFAT	SDHC	10	IU1
Kingston	64GB	exFAT	SDXC	10	IU1
Kingston	128GB	exFAT	SDXC	10	IU1
Samsung	32GB	FAT32	SDHC	10	UHS-I (1)
Samsung	32GB	exFAT	SDHC	10	UHS-I (1)
Samsung	32GB	FAT32	SDHC	10	UHS-I (1)
Samsung	32GB	exFAT	SDHC	10	UHS-I (1)
Samsung	64GB	exFAT	SDXC	10	UHS-I (3)
Toshiba	32GB	FAT32	NA	10	U1
Toshiba	32GB	exFAT	NA	10	U1

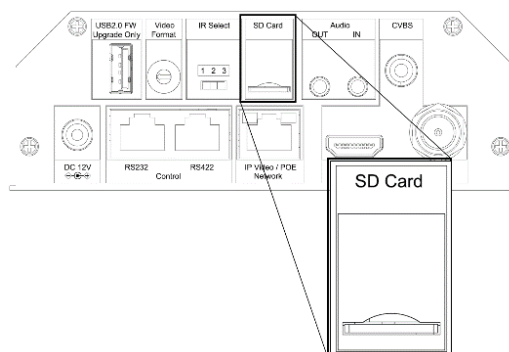

Camera Control Methods and System Configurations

This unit has multiple ways of controlling the camera and various system configuration capabilities using optional products. This section describes the ways of controlling and typical system examples with the required components and usage of each system.

1. Use the Infrared Remote Controller
2. Use RS-232 (VISCA)
3. Use RS-422/485 (VISCA/PELCO P/D)
4. IP Control (See Network Camera User Manual)

Use the Infrared Remote Controller

To operate the camera from a short distance.

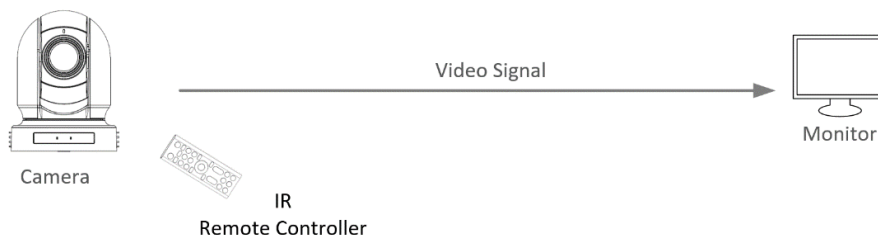

For IR remote control details, refer to Operation Using the Infrared Remote Controller.

Use RS-232 (VISCA)

You can use RS-232 port to connect to optional controllers, such as joystick control keyboard, control PC station, to operate the camera.

To perform pan/tilt and zoom operations using the joystick of the control keyboard, and to perform the Preset operation using the control buttons.

An application software that supports this unit is needed if you use PC station.

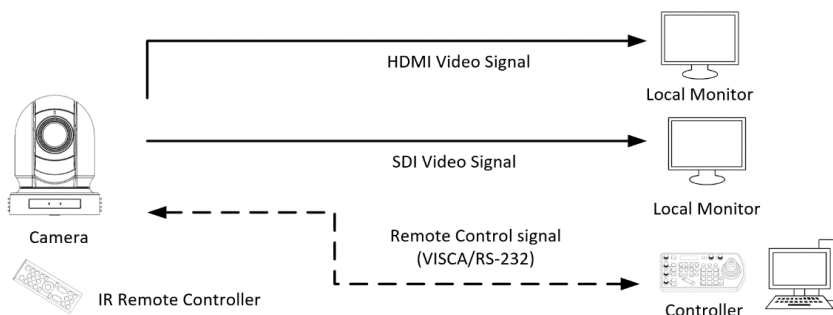

RS232 Connection

1. Set RS232 control method on Bottom Dip Switch.
2. Set Baud Rate on Bottom Dip Switch to the same as Baud Rate setting on the keyboard you are using.
3. Set specific camera address that you want to control the camera for on Bottom Dip Switch.
4. If you want to have the camera address to be automatically assigned by VISCA controller, set camera Dip Switch address to 0.
5. Reboot the camera by turning it Off/On after the Bottom Dip Switch has been set up correctly.
6. Camera supports Daisy Chain connection up to 7 cameras.
7. Use the RJ45 to RS232 (VISCA) control cable. The controller must be VISCA compatible.

8. You can make RS232 connection cable if you have the following applications:

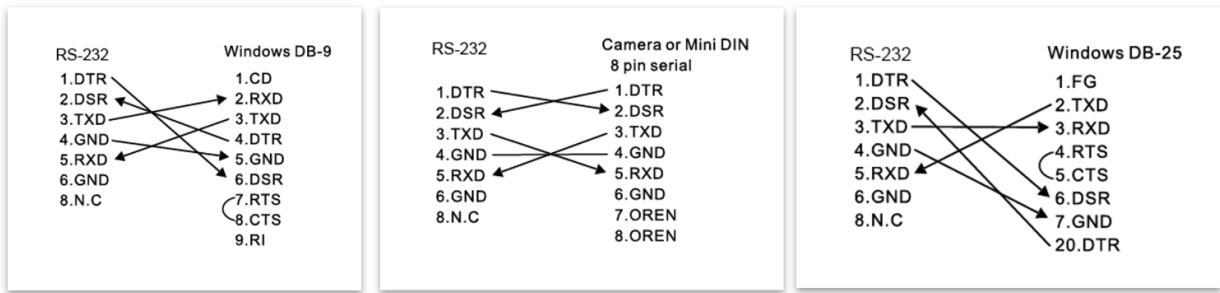

9. Use extension cables included RJ45 to RS232 8 pin Mini Din adaptor to make RS232 connection for your control device.

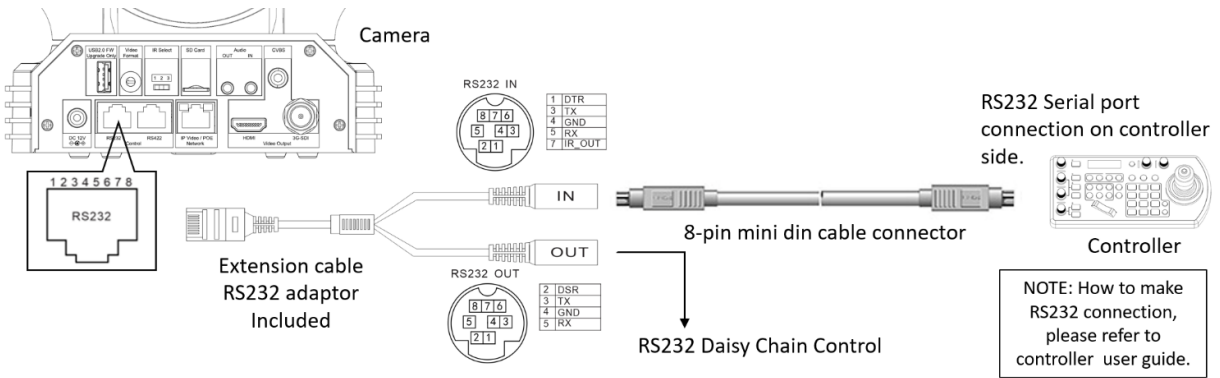

10. Use extension cables included RJ45 to RS422/232 Phoenix terminal contact adaptor to make RS232 connection for your control device.

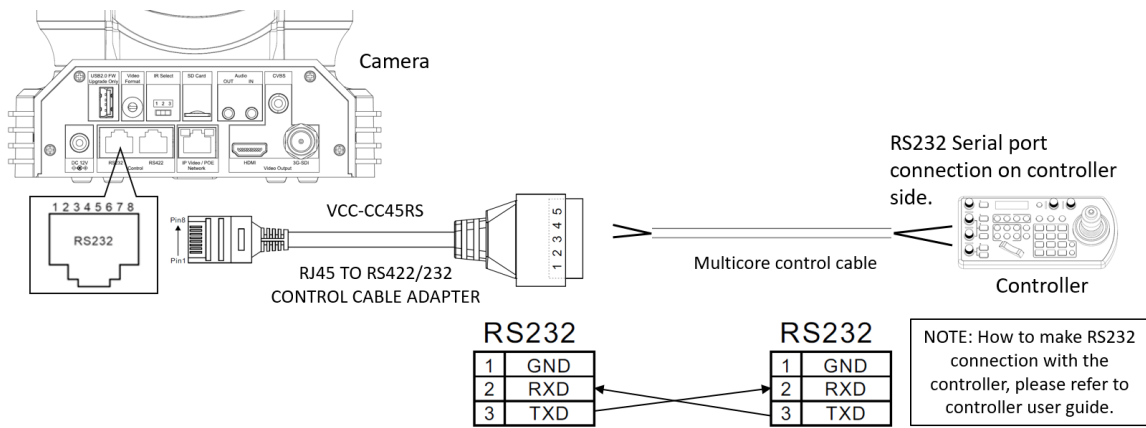

11. Or you can use CAT5/6 network cable (T-568B standard pinout) to make RS232 connection by following the pin definition below:

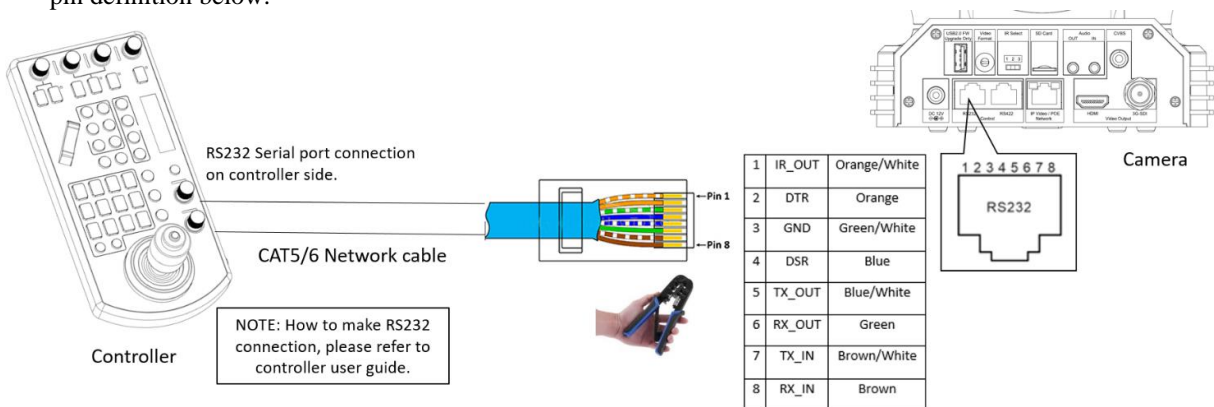

12. How to make RS232 Daisy Chain multiple camera connection with standard RS232 serial port controller as below:

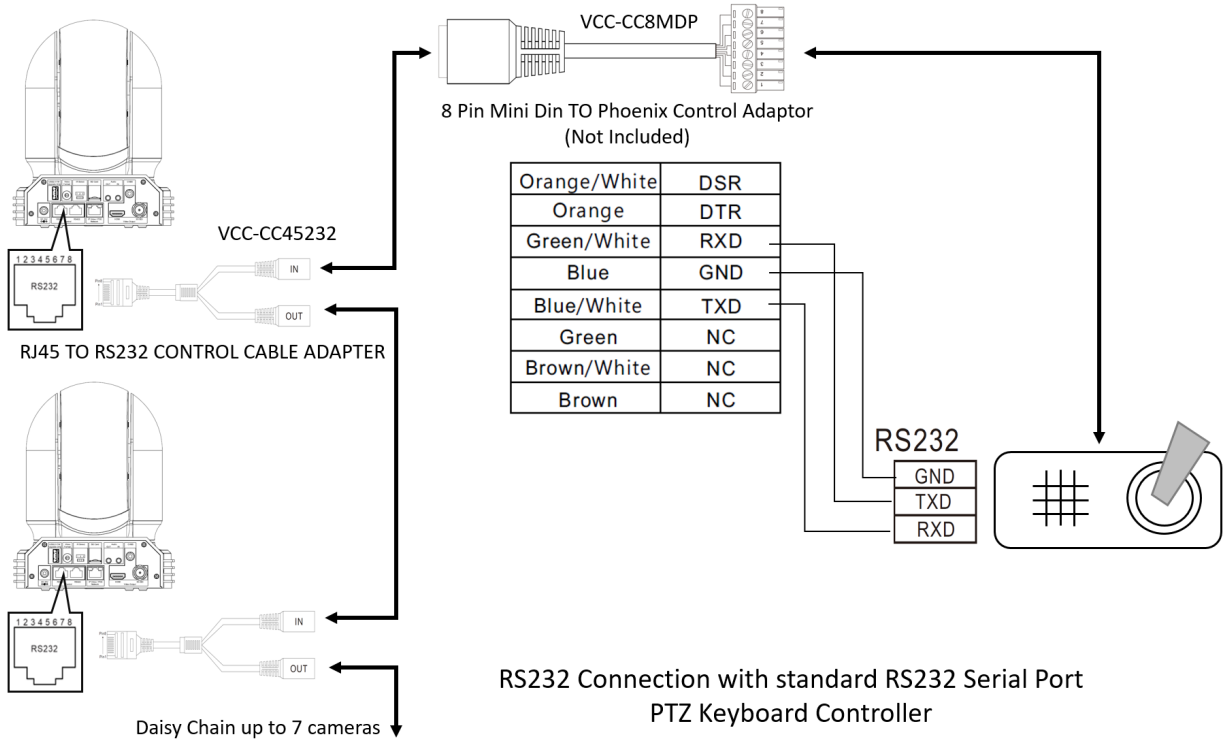

Use RS-422(VISCA) / RS485 (PELCO P/D)

You can use RS-422/485 port connect to optional controllers, such as joystick control keyboard, control PC station, to operate the camera.

To perform pan/tilt and zoom operations using the joystick of the control keyboard, and to perform the Preset operation using the control buttons.

An application software that supports this unit is needed if you use PC station.

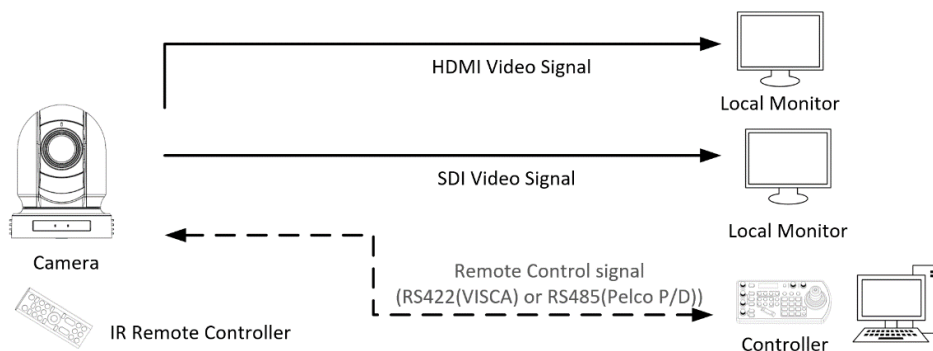

RS422 (VISCA) connection

1. Set RS422 control method on Bottom Dip Switch.
2. Set Baud Rate on Bottom Dip Switch to the same as Baud Rate setting on the keyboard you are using.
3. Set specific camera address that you want to control the camera for on Bottom Dip Switch.
4. If you want to have the camera address to be automatically assigned by VISCA controller, set camera Dip Switch address to 0.
5. Reboot the camera by turning it Off/On after the Bottom Dip Switch has been set up correctly.
6. Use the RJ45 to RS422 control cable. The controller must be VISCA compatible.
7. Camera supports Daisy Chain connection up to 7 cameras.
8. The connection of SONY keyboard is different than other VISCA (Non-Sony) keyboard.

9. How to make RS422 connection and RS422 Daisy Chain multiple cameras connection with SONY controller as below

SONY Keyboard RS422 Connection

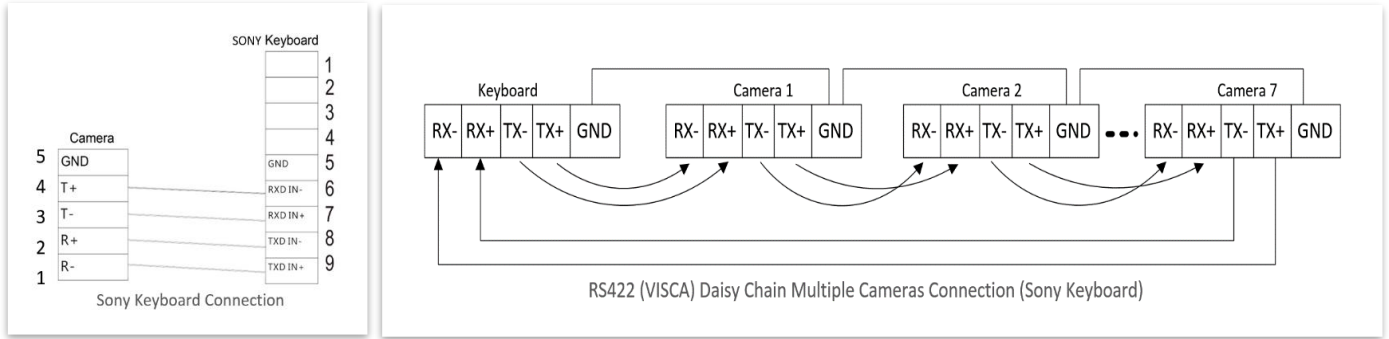

10. How to make RS422 connection and RS422 Daisy Chain multiple cameras connection with Non-Sony controller as below:

VISCA (Non-Sony) Keyboard RS422 Connection

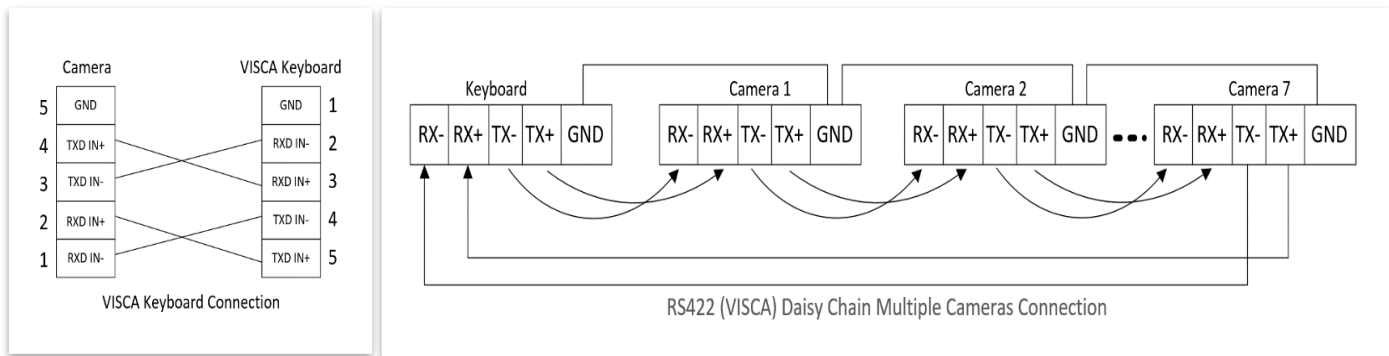

11. Use extension cables RJ45 to RS422 Phoenix connector adaptor included to make RS422 connection for your control device.

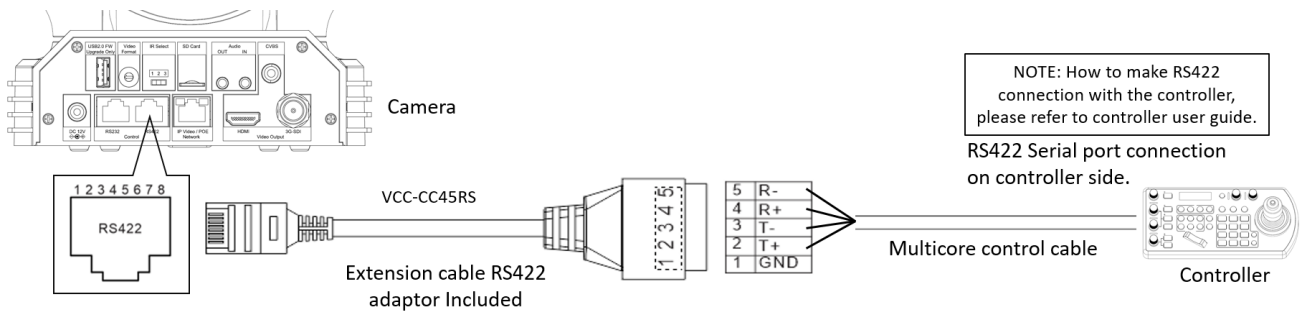

12. Or you can use CAT5/6 T-568B Standard Ethernet cable direct connect between the camera and the controller to make RS422 connection by following the pin definition below:

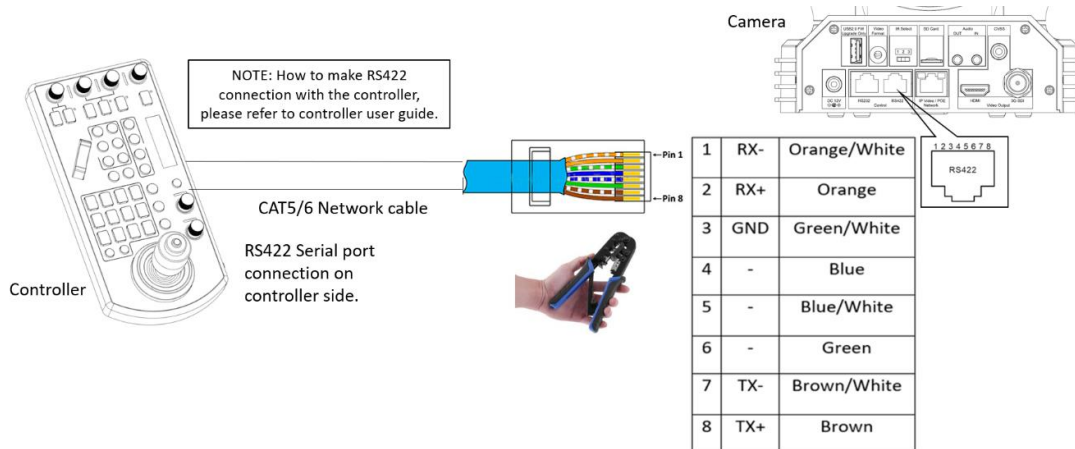

13. How to make RS422 Daisy Chain multiple camera connection with RS422 standard serial port controller:

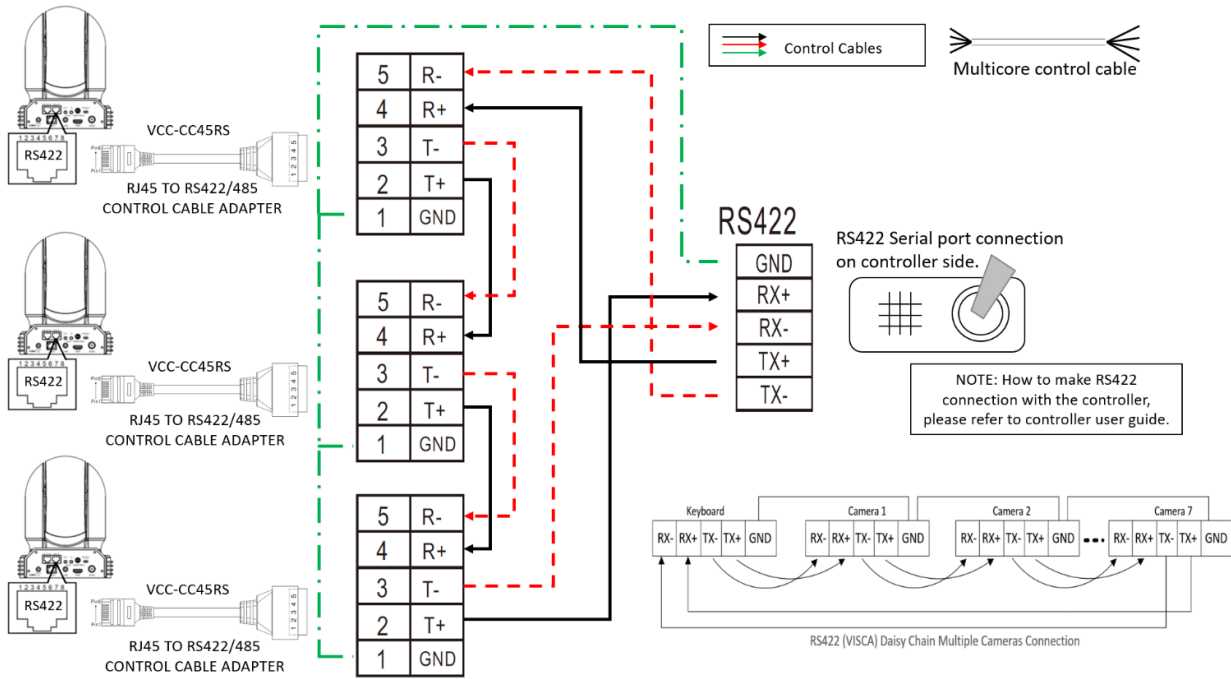

PELCO P/D Keyboard RS485 Connection

NOTE: Use RS422 ports for RS485 connection. Only use TX+ and TX- for RS485 connection.

- Set RS422 control method on Bottom Dip Switch.
- Set Baud Rate on Bottom Dip Switch to the same as Baud Rate setting on the keyboard you are using.
- Set the camera ID on OSD menu by remote controller
- Reboot the camera by turning it Off/On after the Bottom Dip Switch has been set up correctly.
- Use PELCO P/D compatible keyboard.
- Use preset 95# on the keyboard to bring up/exit camera OSD menu.
- Use joystick and Button “OPEN” or “CLOSE” to navigate OSD menu.
- To operate keyboard, please refer to the user manual of the keyboard you are using.

PELCO RS485 Connection

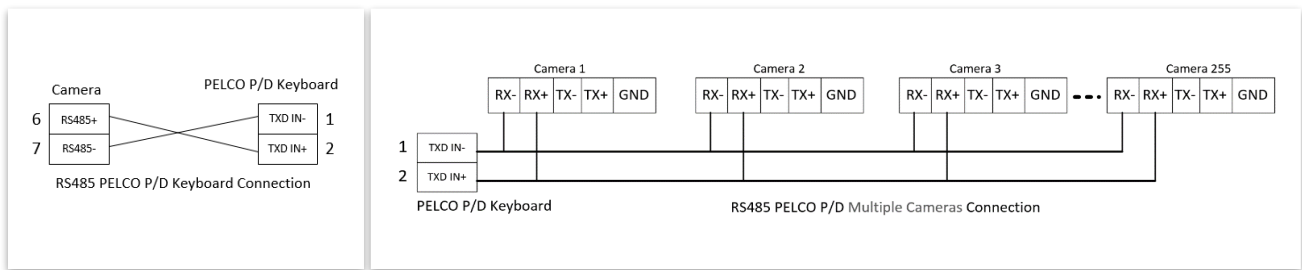

- Use extension cables included RJ45 to RS422 Phoenix connector adaptor to make RS485 connection for your control device.

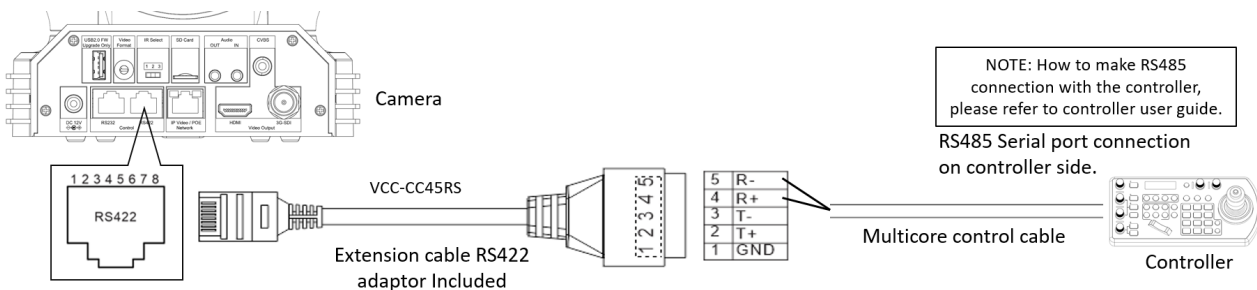

- Or you can use CAT5/6 T-568B Standard Ethernet cable direct connect between the camera and the controller to make RS485 connection by following the pin definition below:

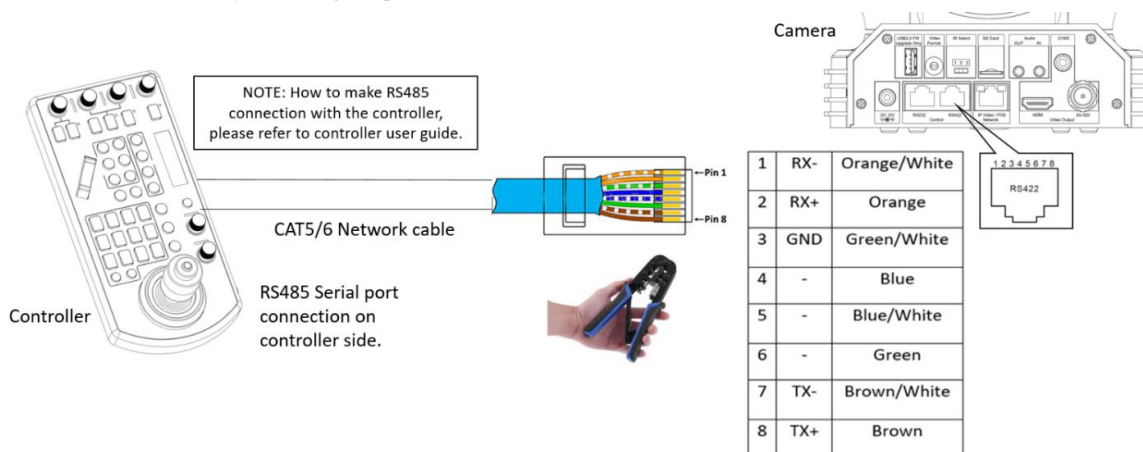

- How to make RS485 multiple cameras connection with RS485 standard serial port controller:

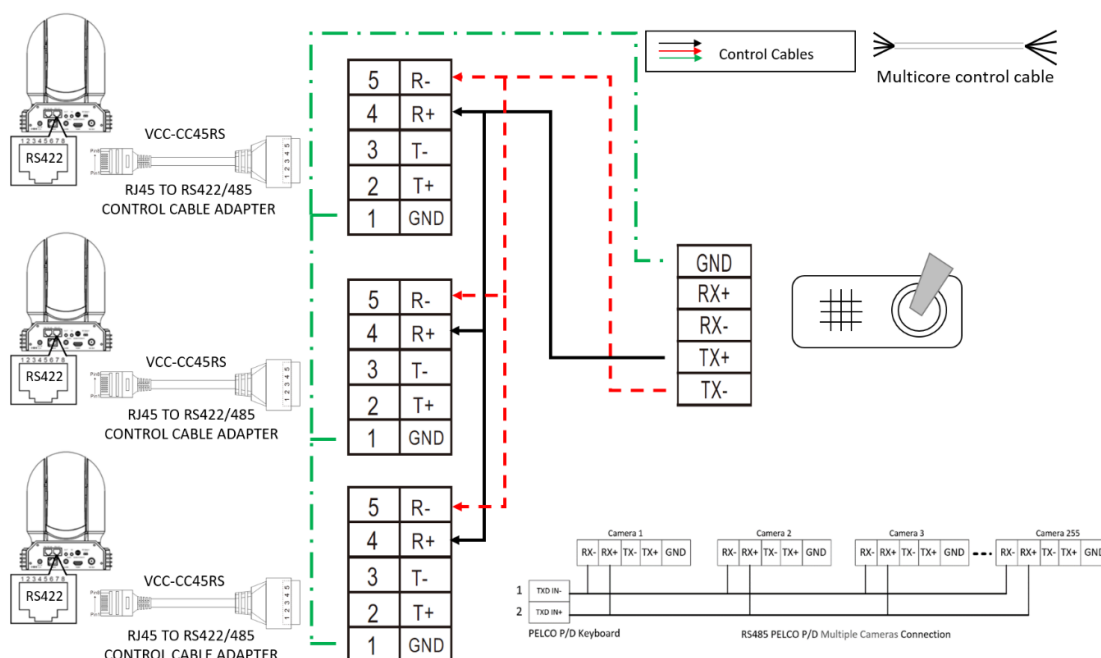

Note

For RS-232 VISCA control, this unit supports daisy chain connection for using multiple cameras. For control details, refer to Operating Instructions of control keyboard/station software.

- You need to match the communication speed (Baud Rate) between the camera and the joystick controller.
- You cannot use the RS-232 connections while you are using the RS422/485 connection.

Operating Multiple Cameras Using RS-232,422/485

- Using RS-232 (VISCA), you can connect to 7 cameras.
- Using RS-422 (VISCA), you can connect to 7 cameras.
- Using RS-485 (PELCO), you can connect to 255 cameras.
- Using RS-485 (PELCO), all camera addresses must be set up before the connection. You can set the camera address by operating OSD menu, or by setting the Dip Switch on the bottom of the camera. In this case, you can use multiple control keyboards.

How to make the connection with BOLIN products

Please see the User Guide "BOLIN Camera and Keyboard Controller Connection" that you can download it at www.bolintechology.com product pages.

VISCA over IP Control

With VISCA over IP function, you can control the camera using VISCA protocol on a controller equipped with IP communication capabilities via LAN.

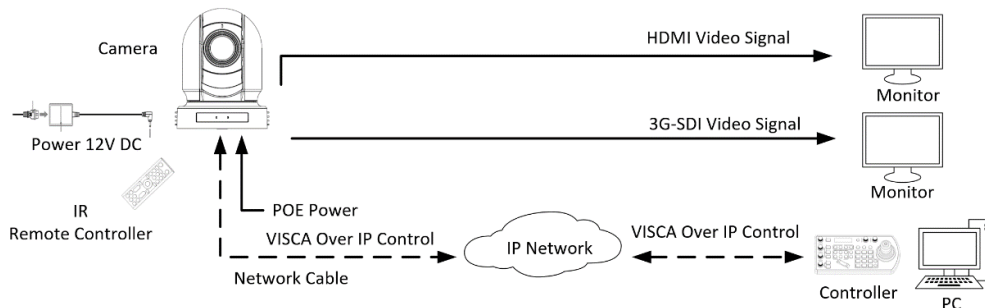

The communication specifications of VISCA over IP are followings:

- Interface: RJ-45 10/100M
- Interface protocol: IPv4
- Transport protocol: UDP
- IP address: 192.168.0.13 By default
- Port: 52381

VISCA over IP Network Configuration

Re-assign the camera

The default information of the IP camera is following:

- Static IP: 192.168.0.13
- Subnet mask: 255.255.255.0
- Gateway: 192.168.0.1
- VISCA over IP control port: **52381**.

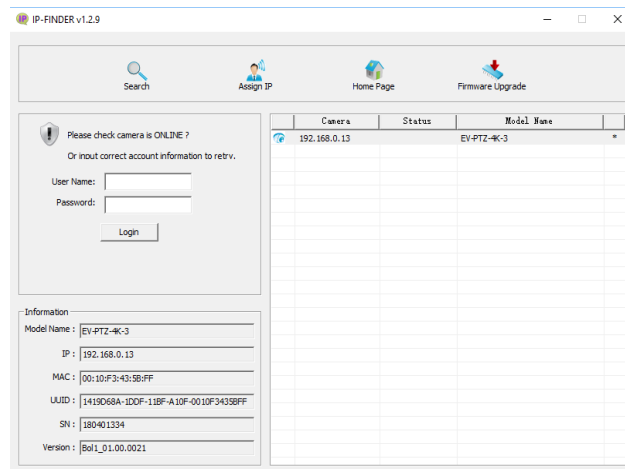

The camera IP address needs to be assigned to the IP address that works with your local network.

Controlling via VISCA over IP

- Connect the network port on the camera to the network switch.
- Set the IP address and other network information appropriately to communicate on your network
- Connect the VISCA over IP-compatible controller to the network
- Configure the controller to access the camera's IP address and VISCA over IP port
- **The IP port within on your control must be set to 52381 to communicate with the camera.**
- Select VISCA protocol on your IP control device.

Recommended way to re-assign the IP address:

1. Create a local network within which the camera and your PC/Laptop are connected.
2. Install and run the IP-FINDER tool (You can contact Bolin Technical support team for tool requirements)
3. The IP-FINDER can find the camera IP address, which is the default :192.168.0.13
4. Click the search button, select the camera you want to Assign IP address, edit the IP address to the one that matches your local network credential.
5. Once the IP address has been changed successfully, you can access the IP camera via your local network.

Note

How to re-assign the IP address to the camera, please refer to user manual Part Two-IP Camera user guide.

DIP SWITCH SETTINGS

The Dip switches are for setting the camera configuration for following items:

1. Camera ID Address for RS-485 PELCO protocol
2. Video output / Video color space
3. RS-232 / RS-422/485 selection
4. RS-232 / RS-422/485 baud rate
5. Video resolutions selection
6. IR remote controller ID

Setting of the BOTTOM DIP Switches

Turn off power to the camera before changing the DIP switch settings.
Power on the camera to have the new Dip Switch setting activated.

From the above list, No.1 Camera ID address and NO.2 Video resolution settings can be set in camera OSD menu as well. The camera takes either the way of OSD menu setting or the way of bottom DIP switch setting. They override each other. After the camera is turned on, the camera takes the last setting before it is turned on, either set through the OSD or bottom DIP switch.

The Bottom DIP Switch Settings

- Bit 1~3: Camera Address setting for VISCA protocol
- Bit 4: Video Output/Video Color Space
- Bit 5: Reserve
- Bit 6: RS-232/RS-422
- Bit 7~8: RS-232/RS-422 Baud Rate

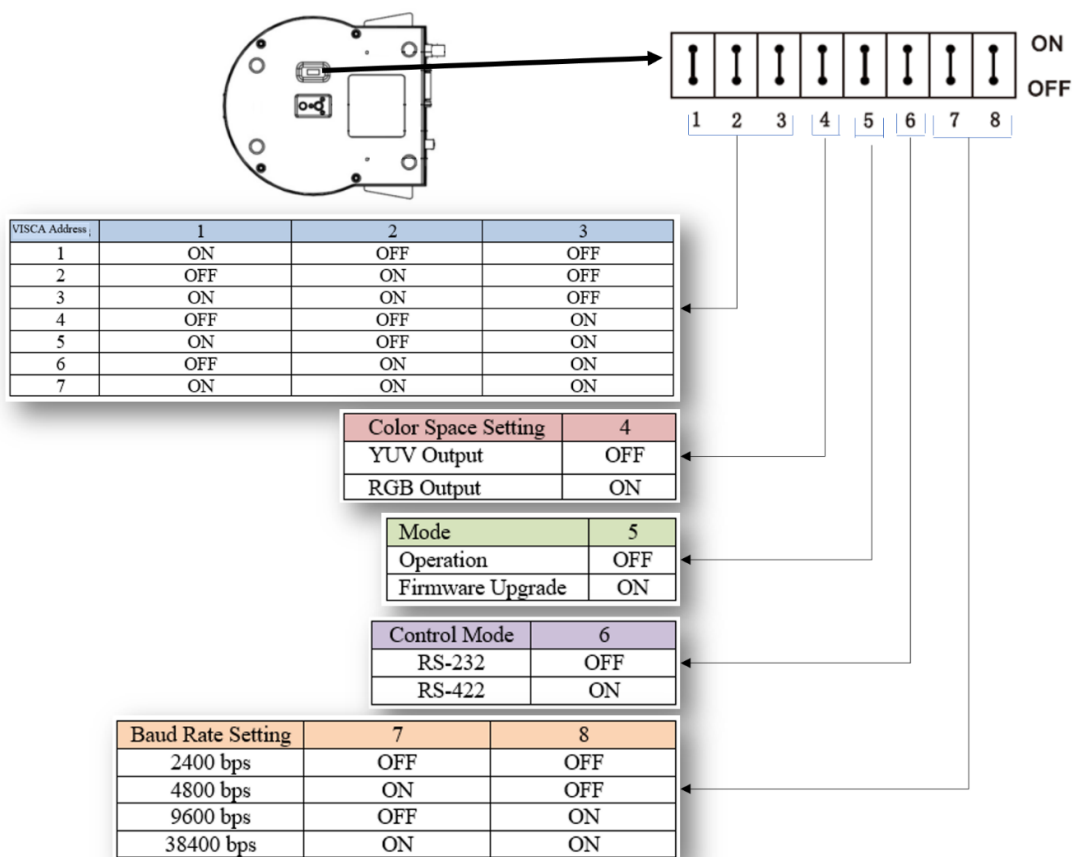

Setting of the back panel Rotate DIP Switches

The Rotate Dip Switch is for setting video format.
Use small screw driver to turn the switch, the arrow points to the Numbers or the Letters. The video format that the Number or Letter stands for refer to the video format as the chart following:

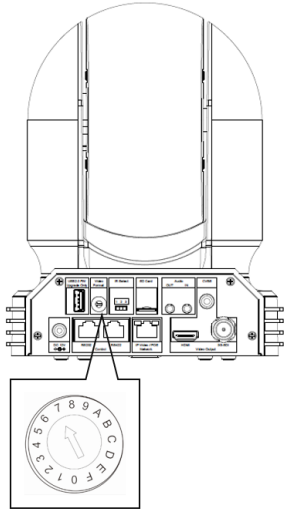

Numbers & Letters	Video Resolution
0	1080i59.94
1	1080P29.97
2	720P59.94
3	1080P59.94
4	1080P50
5	1080I60
6	1080P30
7	1080P60
8	1080I50
9	1080P25
A	720P50
B	1080P50
C	720P25
D	720P30
E	720P60
F	-

IR Remote Controller ID Setting

Set the IR SELECT switch on the back panel of the camera to 1, 2 or 3, which is the camera ID number that you want to operate on the Remote Controller.

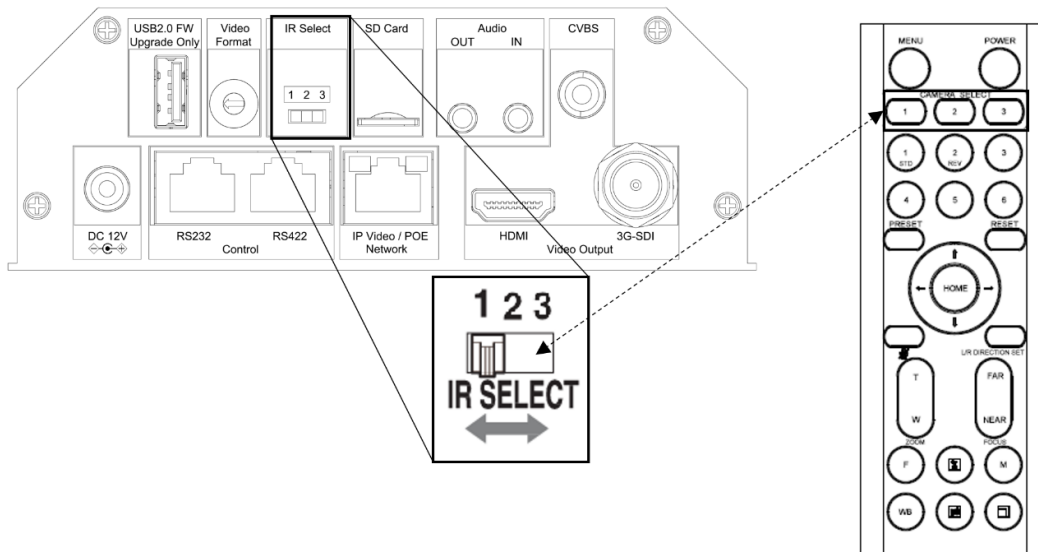

Adjusting and Setting with Menus

About On-Screen Menus

You can change various settings, such as shooting conditions and system setup of the camera, while observing menus displayed on a connected computer screen.

This section explains how to read the on-screen menus before starting menu operations.

The menu parameters may vary according to the different product model numbers.

For a complete configurations menu, see “Menu Configuration” (page 25).

Note

You cannot perform pan/tilt operations while the menu is displayed.

Main Menu

To display the main menu, press the DATA SCREEN button on the supplied infrared remote controller.

1. Selected Items

Selects a setting menu.

The selected item is shown by the cursor. The cursor moves up or down by pressing the “↑, ↓” button on the infrared remote controller.

2. MenuItems

To display a setting menu, select one using the “↑, ↓” button on the infrared remote controller and press the HOME button on the infrared remote controller.

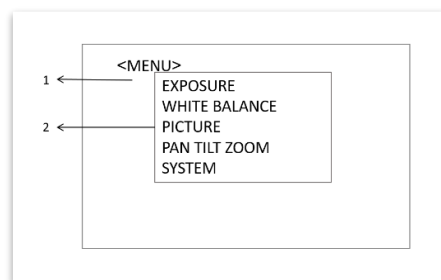

Setting Menus

The setting menu selected on the main menu is displayed.

1. Setting Menu

The name of the setting menu currently selected is displayed here.

2. Selected Item

Selects a setting item.

The selected item is shown by the cursor.

Move the cursor up or down by pressing the “↑, ↓” button on the infrared remote controller.

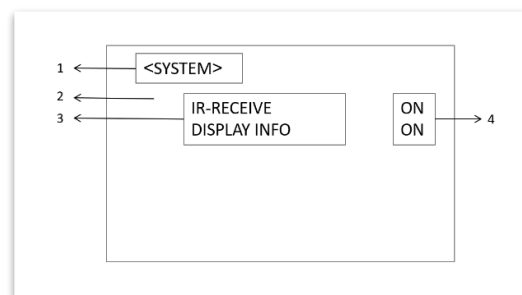

3. SettingItems

The setting items for this setting menu are displayed. Select the setting item using the “↑, ↓” button on the infrared remote controller.

4. Set Value

The currently set values are displayed.

To change a set value, use the “←, →” button on the infrared remote controller.

Note

In some product models, only use “←” button on the infrared remote controller to change the value. To confirm the value, you can use either “→” button or HOME button.

Control Button

You can select the item by pressing “↑, ↓, ←, →” and HOME button.

1. You can select a menu item by “↑, ↓” button on the infrared remote controller. The selected item is shown by the cursor (Color change). You can change the value of the item by pressing “←, →” button.

2. You can move to the next layer by pressing the HOME button.

3. You can return to the normal display by pressing the DATA SCREEN button.

Note

When you are operating the menu using the infrared remote controller, you cannot set IR- RECEIVE in the SYSTEM menu to OFF. To set IR- RECEIVE to OFF, use the appropriate VISCA command.

EXPOSURE Menu

The EXPOSURE menu is used to set the items related to exposure.

MODE (Exposure Mode)

FULL AUTO: The exposure is adjusted automatically using the values set for SLOW SHUTTER, S. SHUTTER LIMIT, AE RESPONSE, GAIN LIMIT, and EX-COMP.

MANUAL: Adjust the GAIN, GAIN LIMIT, electronic shutter speed (SPEED), iris (IRIS), and HIGH SENSITIVITY manually.

IRIS PRI: Iris Priority mode. The exposure is adjusted automatically using the values manually set for iris (IRIS), GAIN LIMIT, and EX-COMP

SHUTTER PRI: Shutter Priority mode. The exposure is adjusted automatically using the values manually set for electronic shutter speed (SPEED), GAIN LIMIT, and EX-COMP

When you select one from various exposure modes, some of the following setting items that are required for the selected mode will appear.

GAIN: Select the gain from the following:

0dB, 3.6 dB, 7.1 dB, 10.7 dB, 14.3 dB, 17.8 dB, 21.4 dB, 25 dB, 28.6 dB, 32.1 dB, 35.7 dB, 39.3 dB, 42.8 dB, 46.4 dB, 50 dB

GAIN LIMIT:

The gain limit can be set at Full Auto, Shutter Priority, Iris Priority, Bright, Spot Exposure and Manual in AE mode. Use this setting when you want to obtain images with a focus on the signal-to-noise ratio

HIGH SENSITIVITY:

This function increases the max gain to allow bright output in darker environments. However, with a strong gain (up to 10x), the captured image will contain a lot of noise

SPEED: Select the electronic shutter speed from the following:

When video format is set to 720P25, 1080P50, 1080i50, 1080P25, 720P50, Speed can be selected from the following:

1/1, 1/2, 1/3, 1/6, 1/12, 1/25, 1/50, 1/75, 1/100, 1/120, 1/150, 1/215, 1/300, 1/425, 1/600, 1/1000, 1/1250, 1/1750, 1/2500, 1/3500, 1/6000, 1/10K.

When video format is set to 720P30, 1080i59.94, 1080P29.97, 720P59.94, 1080P59.94, 1080i60, 1080P30, 1080P60, 720P60, Speed can be selected from the following:

1/1, 1/2, 1/4, 1/8, 1/15, 1/30, 1/60, 1/90, 1/100, 1/125, 1/180, 1/250, 1/350, 1/500, 1/725, 1/1000, 1/1500, 1/2000, 1/3000, 1/4000, 1/6000, 1/10K.

IRIS: Select the iris the following: CLOSE, F14, F11, F9.6, F8.0, F6.8, F5.6, F4.8, F4.0, F3.4, F2.8, F2.4, F2.0, F1.6

SLOW SHUTTER:

When set to "On," the slow shutter functions automatically when the light darkens. This setting is available only when the AE mode is set to "Full Auto." The initial setting is "Auto Slow Shutter Off."

S. SHUTTER LIMIT:

When the subject becomes dark, the shutter speed becomes slow and the gain is increased. This is a function to put a limit on the shutter speed. It prevents the camera shake when you shoot a moving subject in a dark place.

OSD

```
>EXPOSURE
WHITE BALANCE
PICTURE
PAN TILT ZOOM
SYSTEM
```

EXPOSURE MENU: FULL AUTO

```
MODE FULL AUTO
SLOW SHUTTER OFF
S. SHUTTER LIMIT 1/4
AE RESPONSE 01
GAIN LIMIT 21.4dB
EX COMP OFF
```

EXPOSURE MENU: MANUAL

```
MODE MANUAL
GAIN 12dB
GAIN LIMIT 21.4dB
SPEED 1/60
IRIS F1.6
HIGH SENSITIVITY OFF
```

EXPOSURE MENU: IRIS PRI

```
MODE IRIS PRI
IRIS F1.6
GAIN LIMIT 21.4dB

EX-COMP OFF
```

EXPOSURE MENU: SHUTTER PRI

```
MODE SHUTTER PRI
SPEED 1/60
GAIN LIMIT 21.4dB

EX-COMP OFF
```

AE Response:

The slow AE Response function allows you to reduce the exposure response speed. Usually the camera is set up so that the optimum exposure can be obtained automatically within about 1 second. However, using the slow AE response function allows you to lengthen the auto exposure response speed from the initial setup speed

EX-COMP: (Exposure Compensation)

When MODE is set to one of FULL AUTO, SHUTTER PRI or IRIS PRI, set this item to ON to enable exposure compensation. When you set EX-COMP to ON, LEVEL appear and you can select the exposure compensation level from the following:

-10.5, -9, -7.5, -6, -4.5, -3, -1.5, 0, +1.5, +3, +4.5, +6, +7.5, +9, +10.5

If you set the level to 0, exposure compensation will be disabled. Level +10.5 is the brightest and -10.5 is the darkest compensation value.

When EX-COMP is set to OFF, exposure compensation does not function.

WHITE BALANCE Menu

The WHITE BALANCE menu is used to select the white balance mode.

MODE (white balance mode)

Select the white balance mode from the following:

AUTO: This mode computes the white balance value output using color information from the entire screen. It outputs the proper value using the color temperature radiating from a black subject based on a range of values from 2500K to 7500K. This mode is the initial setting.

INDOOR: 3200K Base Mode

OUTDOOR: 5800K Base Mode

OSD

EXPOSURE
>WHITE BALANCE
PICTURE
PAN TILT ZOOM
SYSTEM

WHITE BALANCE MENU

WB MODE	AUTO
---------	------

OPW (One Push White Balance): The One Push White Balance mode is a fixed white balance mode that may be automatically readjusted only at the request of the user (One Push Trigger), assuming that a white subject, in correct lighting conditions, and occupying more than 1/2 of the image, is submitted to the camera. One Push White Balance data is lost when the power is turned off. If the power is turned off, reset One Push White Balance.

NOTE: *When you select the OPW (One Push White Balance)*

Perform the following operations:

1. Place an image of white subject (For example: A piece of white paper) in the center of the screen.
2. Press the HOME button of the infrared remote controller.

The one-push white balance adjustment is activated.

ATW (Auto Tracking White Balance): Auto Tracking White balance (2000K to 10000K), allows the camera to adjust the tone according to the temperature of the light source illuminating the subject

WHITE BALANCE MENU

WB MODE	INDOOR
---------	--------

WHITE BALANCE MENU

WB MODE	OUTDOOR
---------	---------

WHITE BALANCE MENU

WB MODE	OPW
---------	-----

WHITE BALANCE MENU

WB MODE	ATW
---------	-----

USER: This is a mode that enables you to manually set the control of R and B gain up to 256 steps.

NOTE: *When you select USER, R. GAIN (red gain) and B. GAIN (blue gain) appear. You can select each item in the range from 0 to 255.*

OUTDOOR AUTO: This is an auto white balance mode specifically for outdoors. It allows you to capture images with natural white balance in the morning and evening.

SL AUTO: Sodium Vapor Lamp Auto: This is an auto white balance mode that is compatible with sodium vapor lamps.

SL: Sodium Vapor Lamp: This is a fixed white balance mode specifically for sodium vapor lamps.

SLO AUTO: Sodium Vapor Lamp Outdoor Auto: This is an auto white balance mode specifically for outdoors, which is compatible with sodium vapor lamps.

WHITE BALANCE MENU

WB MODE	USER
R GAIN	106
B GAIN	217

WHITE BALANCE MENU

WB MODE	OUTDOOR AUTO
---------	--------------

WHITE BALANCE MENU

WB MODE	SVL AUTO
---------	----------

WHITE BALANCE MENU

WB MODE	SVL
---------	-----

WHITE BALANCE MENU

WB MODE	SVL OUTDOOR A.
---------	----------------

PICTURE1 Menu

SHARPNESS:

Picture sharpness value ranges from 0 to 15. You can enjoy emphasized edge and high-resolution images.

EFFECT: (Picture Effect)

It consists of the following functions:

B&W: MonochromeImage

Image effect from Off, B&W

NOISE REDUCTION:

Noise reduction - you can enjoy clearer images by removing unnecessary noise. You can select 6 levels from OFF (MIN), 1 to 5 (MAX).

FLIP:

Image E-Flipper – Used when ceiling mounting or upright mounting. Set to OFF is upright mode, set to ON is for ceiling mount.

MIRROR:

You can have the image as seen in a mirror, with the right side as though it were the left.

DE-FLICKER:

You can turn it ON if the Video output format frame rate is difference from your country's electricity Frequency.

WDR: (Wide dynamic range mode): WDR feature is available on certain product models.

Wide Dynamic: ON, OFF. The camera distinguishes light and dark areas within the same scene, adjusts the brightness for dark areas, and also controls the blown-out highlights.

You can select the wide dynamic range mode between ON and OFF

COLOR

You can configure the color gain from 1-15. Use this setting when bright color is particularly important.

HUE

You can adjust color phase from 1-15.

CONTRAST

You can adjust the contrast level in the range from 0 (00h) to 255 (FFh). The initial setting is 128 (80h). The smaller the value is, the lower the contrast becomes, and the larger the value is, the higher the contrast becomes.

OSD

EXPOSURE
WHITE BALANCE
>PICTURE
PAN TILT ZOOM
SYSTEM

PICTURE MENU

SHARPNESS	3
EFFECT	OFF
NOISE REDUCTION	3
FLIP	OFF
MIRROR	OFF
DE-FLICKER	OFF
WDR	OFF
COLOR	5
HUE	6
CONTRAST	128

PICTURE2

CHROMA:

You can set the brightness from OFF, LOW, MID, HIGH

in each mode of the variable gamma mode.

HLC MODE:

HLC (Highlight Light Compensation) is a function to adjust AE and AF, and to perform the masking of light area as required when a high intensity spot light is detected.

BACKLIGHT COM.

When the background of the subject is too bright, or when the subject is too dark due to shooting in the AE mode, back light compensation will make the subject appear clearer.

STABILIZER (Available on 30X, not available on 20X)

When the image stabilizer function is set to ON, you can obtain the image with less screen blur caused by shaking. The correction effect can be achieved at the vibration frequency around 10 Hz. The image stabilizer function uses the digital zoom method. Although there are changes in the angle of view and resolution, the sensitivity is maintained.

Note: The image stabilizer function may not work under the environment of high frequency vibration components. When using the camera under such environment, set the image stabilizer function to Off.

STABLE ZOOM: (Available on 30X, not available on 20X)

Stable Zoom is a function to perform correction using the image stabilizer function according to the zoom magnification and zoom the image up to approx. 24× smoothly by combining the optical zoom with the digital zoom. By zooming the image furthermore using the digital zoom, the image is zoomed up to 288×. On the wide side, the image without the deterioration in resolution can be obtained because the digital zoom is not used. On the other hand, the correction effect by the image stabilizer function is maximized on the tele side, reducing the blur.

GAMMA:

In this mode, the gamma can be set to value from 0 to 1.

OSD

EXPOSURE
WHITE BALANCE
PICTURE1
>PICTURE2
PAN TILT ZOOM
SYSTEM

PICTURE2

CHROMA	OFF
HLC MODE	OFF
BACKLIGHT COM.	OFF
STABILIZER	OFF
STABLE ZOOM	OFF
GAMMA	0

PAN TILT ZOOM Menu

The PAN TILT ZOOM menu is used to select the pan/tilt/zoom mode.

DIGITAL ZOOM:

Set to DIGITAL ZOOM ON, 12X digital zoom is activated. You can set digital zoom to ON or OFF. When set to OFF, digital zoom does not operate, and only optical zoom is available. When set to ON, digital zoom takes over after optical zoom reaches MAX (20X/30X). Up to 200X/300X can be zoomed digitally.

When digital zoom is available, the resolution decreases

ZOOM RATIO OSD (Zoom times display):

Set Ratio OSD to ON, the number of the zoom ratio that you are operating displays on screen.

AF SEN:

NORMAL: Reaches the highest focus speed quickly. Use this when shooting a subject that moves frequently.

LOW: Improves the stability of the focus. When the lighting level is low, the AF function does not take effect, even though the brightness varies, contributing to a stable image.

MF SPEED:

Manual Focus variable speed, that has eight speed levels.

NEAR LIMIT:

Can be set in a range from OVER, 1cm, 11cm, 30cm, 80cm, 1.2m, 1.4m, 1.6m, 2.0m, 2.5m, 3.1m, 4.2m, 6m, 10m, 20m.

ADAPTIVE P/T:

Set to ON, Pan Tilt speed would be adaptive with the zoom range.

Turn ON to automatically adjust the Pan and Tilt speed with various zoom ratios. For example, the higher zoom ratio you use, the slower the speed of P/T.

P/T SPEED:

Set P/T Speed value to from 0 to 5 (The speed from low to high), to change the speed of P/T on remote controller.

OSD

EXPOSURE
WHITE BALANCE
PICTURE
>PAN TILT ZOOM
SYSTEM

PAN TILT ZOOM MENU

DIGITAL ZOOM	OFF
ZOOM RATIO OSD	OFF
AF SEN	LOW
MF SPEED	2
NEAR LIMIT	30cm
ADAPTIVE PT	ON
P/T SPEED	3
PRESET SPEED	5
PAN DIR	NORMAL
TILT DIR	NORMAL

PRESET SPEED:

Set preset speed value from 0 to 5 to change the preset speed.

PAN DIR:

Camera horizontal Left and right orientation setting, option: Normal/Invert

TILT DIR:

Camera tilt up and down orientation setting, option: Normal/Invert

SYSTEM Menu

PELCO ID

When using RS485 (PELCO P/D) control, Set Camera ID to the address that you want to control to. This value is from 001-255.

IR-RECEIVE (Infrared Signal Reception)

When this is set to OFF, the camera does not receive the signal from the infrared remote controller.

Be sure to keep it set to ON when you use the infrared remote controller.

Note

You cannot set IR-RECEIVE to OFF when you operate the menu using the infrared remote controller. To set it to OFF, use the appropriate VISCA controller.

DISPLAY INFO

When this item is set to ON, the message of the camera configuration appears for about 3 seconds on the screen, after the camera is powered on or rebooted.

PRESET MEMORY:

This feature allows you to save the image parameter to PRESET memory, turn it on to save most image parameters like as picture, white balance, exposure, focus mode, zoom positions when you call the preset.

FACTORY RESET

You can select this item to set camera back to Factory Default setting by pressing HOME button to confirm the action. All data of the camera that have been set will be deleted.

RELOAD PRESET 1:

When this item is set to ON, preset 1 is set to Home position. The camera goes to Home position when it is powered on or reset.

AUTO FOCUS

Set speed of auto-focusing from Low to Normal.

VIDEO FORMAT:

You can change the video format by adjusting this item. Select the item, press “←” button to choose the video format you want to set to, then press “→” (Pressing “→” button changes value on some product models) or HOME button to confirm it. After you confirm your choice, press HOME button again to restore it. The camera will reboot by itself. The new video format is activated.

You can cancel it by pressing the DATA SCREEN button.

Depending on the video client software you are using, some video software may need to be restarted to obtain the new video format.

The video formats that you can select from are: 1080P:60/59.94/50/30/29.97/25, 1080I:60/59.94/50, 720P:60/59.94/50/30/25

SV:

Software Version Number that is currently running on the camera, you may need this information for technical support.

Note

The camera video format can be changed by setting bottom DIP switch as well.

OSD

EXPOSURE
WHITE BALANCE
PICTURE
PAN TILT ZOOM
>SYSTEM

SYSTEM MENU

PELCO ID	001
IR-RECEIVE	ON
DISPLAY INFO	ON
PRESET MEMORY	ON
FACTORY RESET	
RELOAD PRESET 1	ON
AUTO FOCUS	NORMAL
FORMAT	1080P29.97
SV:	VOB1100S36040A004

Upgrading MCU Firmware

MCU Firmware can be upgraded by following these steps:

1. Load the .bin file onto a flash drive (Formatted as FAT32), and name the file “HD20.bin”
2. With the camera powered off, insert the flash drive to the USB port on the back panel of the camera
3. Apply power to the camera

The green indicator light above the lens will turn red for a few seconds while the upgrade takes place. Once the upgrade is finished, the light will turn green, and the camera will proceed through a normal boot cycle. Check the data on the OSD boot screen

NOTE:

The firmware upgrade process is intended to be performed under the supervision of a BOLIN-Authorized repair technician. For assistance with this, please contact your authorized BOLIN Technology dealer, installer, or integrator. BOLIN Technology Technical Support can also be reached for assistance with this process

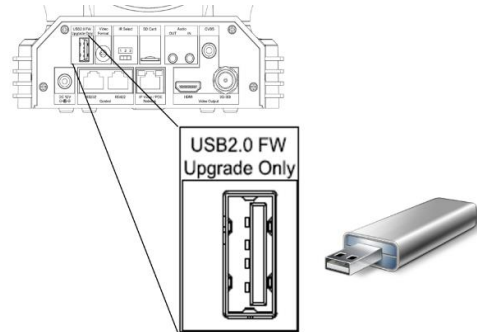

Operation Using the Infrared Remote Controller

Pan/Tilt and Zoom Operation

Panning and Tilting

1. Press the POWER switch.
The camera will turn on and perform the pan/tilt reset operation automatically.
2. Press the arrow button to pan or tilt the camera.
While checking the picture on the screen, press the desired arrow button.

To move the camera in short increments, press the button just for a moment.

To move the camera in long increments, press and hold the button.

To move the camera diagonally, press the “←, →” button while holding down the “↑, ↓” button.

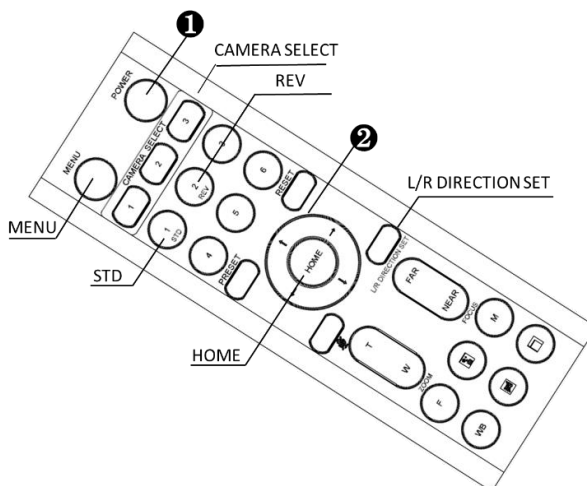

Restore to starting position

Press the HOME button.

If the camera moves in a different direction from the one that you intended

The camera is preset so that the image output from the camera is rotated toward the right whenever you press the “←, →” button.

To face the camera toward the opposite direction

You might wish to face the camera toward the opposite direction from that of the button you pressed, for example, when you change the direction of the camera while checking the picture on the screen. In such a case, press the 2 (REV) button while holding down the L/R DIRECTION SET button.

Arrow button	Movement of the camera	Setting
		 While holding down Press

To reset the setting

To reset the setting, press the 1 (STD) button while holding down the L/R DIRECTION SET button.

Arrow button	Movement of the camera	Setting
		 While holding down Press

Note

The above setting only changes the signal emitted from the infrared remote controller, and does not change the setting of the camera itself. Therefore, repeat the setting for each infrared remote controller if you are using more than one infrared remote controller.

When the STANDBY lamp is blinking

If the camera is moved forcibly, or a finger or other object interferes with camera movement, the camera may fail to memorize the pan/tilt position.

Press the PAN-TILT RESET button to reset the pan/tilt position.

Zooming

Button [T] - Zoom-IN and [W] - Zoom-OUT.

Button [F] – FAST mode.

Press once and the LED turns red to activate the Fast Zoom Speed Mode, press again to go back to normal Zoom Speed mode.

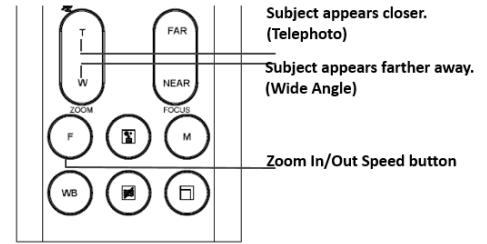

Operating Multiple Cameras with the Infrared Remote Controller

1. Set the DIP Switch on the bottom of the camera to the number of camera you want to operate to 1, 2 or 3. (See bottom DIP Switch setting instruction)
2. Press the CAMERA SELECT button on the infrared remote controller that corresponds to the number set in step

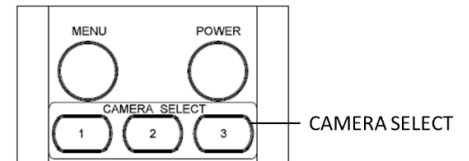

Then, you can operate the camera(s) specified by number. Every time you operate the camera(s) using the infrared remote controller, the CAMERA SELECT button pressed in step 2 lights.

Adjusting the Camera

Focusing on a Subject

Focusing the camera on a subject automatically

Press the AUTO button.

The camera focuses on the subject at the center of the screen automatically.

Focusing the camera on a subject manually

After pressing the MANUAL button, press either the FAR or the NEAR button to have the camera focus on the subject.

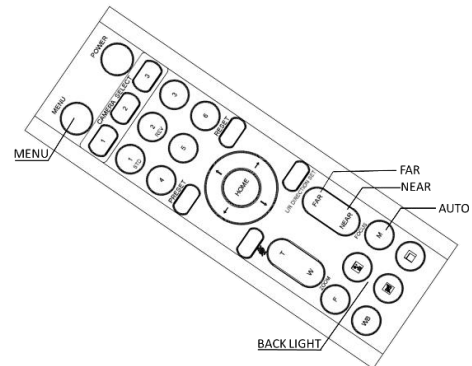

Shooting with Back Lighting

When you shoot a subject with a light source behind it, the subject becomes dark. In such a case, press the BACK LIGHT button.

To cancel the function, press the BACK LIGHT button again.

Note

The BACK LIGHT function is effective if MODE is set to FULL AUTO in the EXPOSURE menu of the camera.

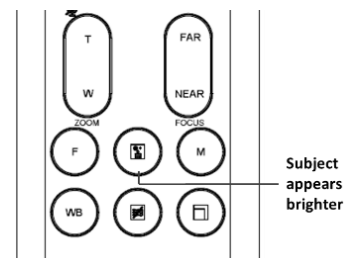
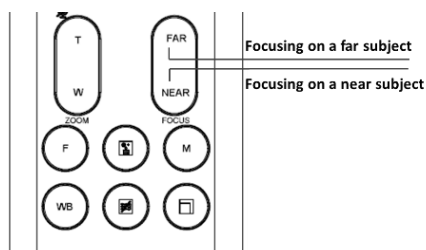

Storing the Camera Settings in Memory — the Presetting Feature

Memory (Preset)

Using the preset function, 6 sets of camera shooting conditions can be stored and recalled. 6 sets of camera shooting conditions can be stored and recalled by using remote controller. Up to 128 presets via protocol programming.

This function allows you to achieve the desired status instantly, even without adjusting the following items each time.

- Pan/Tilt Position
- Zoom Position
- Focus Auto/Manual
- Focus Position
- AE Mode
- Shutter control parameters
- Bright Control
- Iris control parameters
- Gain control parameters
- Exposure Compensation On/Off
- Exposure Level
- Backlight Compensation On/Off
- White Balance Mode
- R/B Gain
- Aperture Control
- WD Parameter

The settings stored using this function are recalled when the power is turned on.

1. Press the PAN-TILT RESET button to reset the pan/ tilt position.
2. Adjust the position, zooming, focusing and backlighting of the camera.

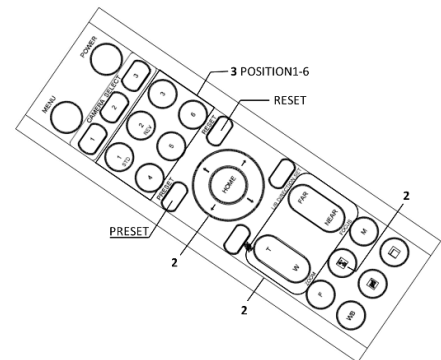

While holding down the PRESET button, press any of the POSITION buttons, 1 to 6, in which you want to store the settings.

Recalling the stored settings

Press any of the POSITION buttons, 1] to [6], in which you have stored the settings.

Cancelling the preset memory

While holding down the RESET button, press the POSITION button from which you want to cancel the settings.

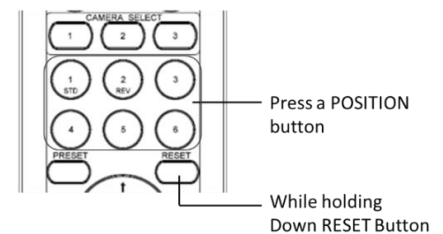
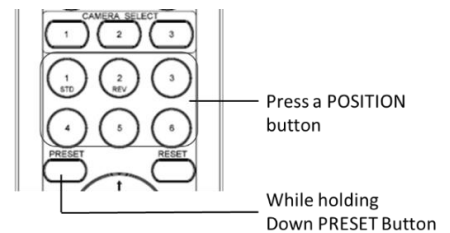

Notes

- When the power is turned on, the camera starts with the settings stored in POSITION 1.
- If you want to retain the previous pan and tilt positions, etc. before the power is turned off and turned on again, store those positions in POSITION 1.
- When you are storing or cancelling the settings in one POSITION, you cannot call up, store or cancel the settings in another POSITION.
- When the menu is displayed on the screen, you cannot perform the operation for storing, recalling, or cancelling the setting. Be sure to return to the normal display before starting these operations.

Changing Resolutions

- Press the Video Format Switching button to populate a menu where you can switch resolutions
- Use the arrow keys to navigate
- Press Home to select
- Screen will show 'CHANGING...'
- Press Menu to exit

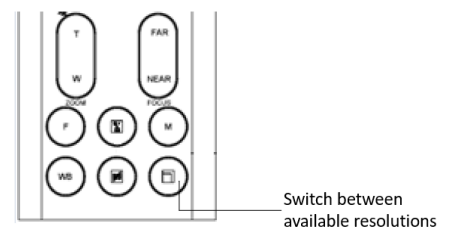

Menu Configuration

The menus of the camera are configured as described below. The initial settings of each item are in bold.

SDI Menu Configuration

Menu	EXPOSURE	MODE	FULL AUTO	SLOW SHUTTER	ON, OFF
				S. SHUTTER LIMIT	1/1, 1/2, 1/4, 1/8, 1/15, 1/30
				AE RESPONSE	1 - 48
				GAIN LIMIT	10.7dB, 14.3dB, 17.8dB, 21.4dB, 25dB, 28.6dB, 32.1dB, 35.7dB, 39.3dB, 42.8dB, 46.4dB, 50dB
			MANUAL	GAIN	0, 2, 4, 6, 8, 10, 12, 14, 16, 18, 20, 22, 24, 26, 28 Db
				GAIN LIMIT	10.7dB, 14.3dB, 17.8dB, 21.4dB, 25dB, 28.6dB, 32.1dB, 35.7dB, 39.3dB, 42.8dB, 46.4dB, 50dB
				SPEED	1/1, 1/2, 1/4, 1/8, 1/15, 1/30, 1/60, 1/90, 1/100, 1/125, 1/180, 1/250, 1/350, 1/500, 1/725, 1/1000, 1/1500, 1/2000, 1/3000, 1/4000, 1/6000, 1/10K sec
				IRIS	CLOSE, F14, F11, F9.6, F8.0, F6.8, F5.6, F4.8, F4.0, F3.4, F2.8, F2.4, F2.0, F1.6
				HIGH SENSITIVITY	OFF, ON
			IRIS PRI	IRIS	CLOSE, F14, F11, F9.6, F8.0, F6.8, F5.6, F4.8, F4.0, F3.4, F2.8, F2.4, F2.0, F1.6
				GAIN LIMIT	10.7dB, 14.3dB, 17.8dB, 21.4dB, 25dB, 28.6dB, 32.1dB, 35.7dB, 39.3dB, 42.8dB, 46.4dB, 50dB
			SHUTTER PRI	SPEED	1/1, 1/2, 1/4, 1/8, 1/15, 1/30, 1/60, 1/90, 1/100, 1/125, 1/180, 1/250, 1/350, 1/500, 1/725, 1/1000, 1/1500, 1/2000, 1/3000, 1/4000, 1/6000, 1/10K sec
				GAIN LIMIT	10.7dB, 14.3dB, 17.8dB, 21.4dB, 25dB, 28.6dB, 32.1dB, 35.7dB, 39.3dB, 42.8dB, 46.4dB, 50dB
		EX-COMP			OFF, ON
	WHITE BALANCE	MODE	AUTO		
			INDOOR		
			OUTDOOR		
			OPW		
			ATW		
			USER	R GAIN	0-255
				B GAIN	0-255
			OUTDOOR AUTO		
			SVL AUTO		
			SVL		
			SVL OUTDOOR A.		
	PICTURE1	SHARPNESS			0-15
		EFFECT			OFF, B&W
		NOISE REDUCTION			OFF, 1-5
		FLIP			OFF, ON
		MIRROR			OFF, ON
		DE-FLICKER			OFF, ON
		WDR			OFF, ON
		COLOR			1-15
		HUE			1-15
		CONTRAST			0-255
	PICTURE2	CHROMA SUPPRESS			OFF, LOW, MID, HIGH
		HLC MODE			OFF, ON
		BACKLIGHT COM.			OFF, ON
		STABILIZER			OFF, ON
		STABLE ZOOM			OFF, ON
		GAMMA			0, 1

PAN TILT ZOOM	DIGITAL ZOOM	OFF, ON
SYSTEM	ZOOM RATIO OSD	OFF, ON
	AF SEN.	LOW, NORMAL
	MF SPEED	0-7
	NEAR LIMIT	OVER, 1cm, 11cm, 30cm, 80cm, 1.2m, 1.4m, 1.6m, 2.0m, 2.5m, 3.1m, 4.2m, 6m, 10m, 20m
	ADAPTIVE PT	OFF, ON
	P/Z SPEED	0-5
	PRESET SPEED	0-5
	PAN DIR	NORMAL, INVERT
	TILT DIR	NORMAL, INVERT
	PELCO ID	001-255
	IR-RECEIVE	OFF, ON
	DISPLAY INFO	OFF, ON
	PRESET MEMORY	OFF, ON
	FACTORY RESET	
RELOAD PRESET 1	OFF, ON	
VIDEO FMT	1080p:60/59.94/50/30/29.97/25; 1080i:60/59.94/50; 720p:60/59.94/50/30/25	
SV:	V0B1100S36040AD04	

Dimension

Unit: mm

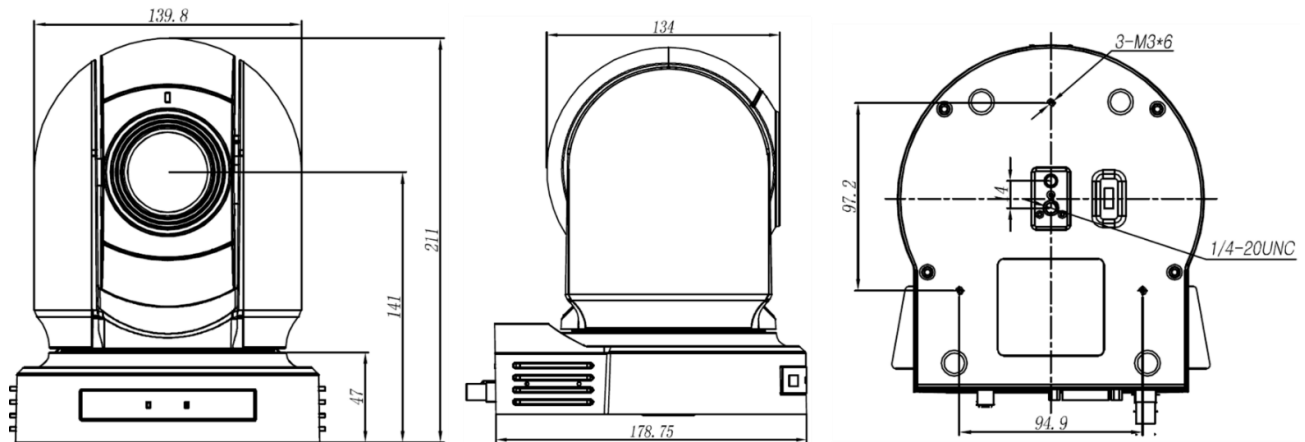



www.bolintechnology.com

2082 TECHNOLOGY LLC

dba

BOLIN TECHNOLOGY