



CLAR

## Illumi Max 500

High Performance LED Light

It's All Possible with  
CLAR Wireless LED.



**The CLAR ILLUMI MAX 500** is a COB\* LED blast of light when you need it most. Watts of fierce LED raw energy that illuminates like no other single head 5600°K fixture. Exceptionally 95+ accurate CRI color rendition, combined with a whopping 59,000 lux of output (at 1 meter with 65° reflector) and longrange wireless 2.4GHz radio remote control, make this fixture the performance champ for videographers and image creators of all stripes; perfect for broadcast video, photography, television production, and studio filmmaking. Where it really slams the competition is with the standard reflector at the crucial 2 meter mark, delivering 12,000 lux of even, natural and vibrant light. The CLAR ILLUMI MAX series is the answer for no compromise light for spot applications with an accessory Fresnel, sweeping floodlight coverage with a standard reflector or using the power for indoor bounce light solutions.

The lightweight control/power module box is a separate unit for transferring all the settings to the light source for easy access to the direct input of brightness values. Placement of the head is flexible, safe and independent. The power module pack is compactly designed to handle secure lead joining, first-class cable links to the main head, and DMX connectivity. The clear LCD information panel displays Channel, Levels, DMX status and the Effects selection.

The ability to be free of AC mains, with connectivity to onboard slots for dual V-mount batteries, eliminates the need to hook up expensive power supplies.

Your dream to be in LED land, cool and stable, free of all of the heat, danger, and hassle of heavy-duty cabling, is realized in the CLAR ILLUMI MAX 500.

## Features

- Compact mega bright 500 watts of power
- COB LED technology for over -the-top output at 430,000 lux (65° reflector at 0.5m)
- Flawless wireless 2.4Ghz radio remote control
- Intelligent cooling with silence as the objective
- Built for portability and strength
- Luxurious Color Rendition - beyond 95Ra
- Coverage a lighting professional would appreciate
- Accepts Bowens modifiers from Fresnel Spot to Magnum Reflectors to Grand Softboxes

## Overview and Instructions

### Light Fixture

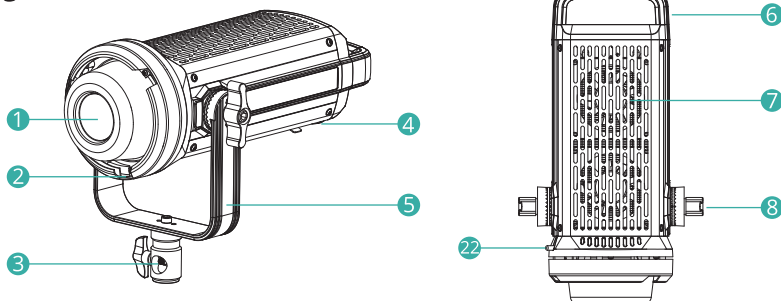

#### 1. COB LED

The COB LED is the heart of the CLAR Illumi Max 500 lamp. A single 40mm COB high power LED module, producing 500 watts of more than 95 CRI at 5600°K. \*See the end of the manual for a description of the technology.

#### 2. Bowens Mount

Affix any Bowens Type-S light modifier to this mount. Twist the modifier clockwise to mount. Pull back on the spring-loaded lock to release then twist the modifier counterclockwise to remove.

#### 3. Stand Adapter

#### 4. Power and Data Socket

Match the 4-pin XLR connector cable from the Power Control Box Connection Line Socket, and attach it to this socket to link power and data.

#### 5. Yoke

#### 6. Handle

#### 7. Fans

The thermo-sensitive cooling system triggers the fans to ventilate the lamp circuitry silently. The fan operates anytime the light is on.

#### 8. Angle Adjustment Knob

## Control Box

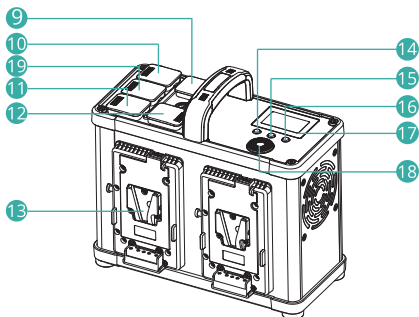

### 9. DMX Sockets

DMX cable ports for IN and OUT.

### 10. Cable Line Socket

Connect the Control Box to the Lamphead through a 3-conductor locking PowerCON cable.

### 11. Power Cord Socket

Insert the 3-conductor locking PowerCON to AC for connection to main AC lines, (neutral and ground) contact in this socket. Operates worldwide on AC100-240V ~50/60Hz, with an output of DC36V 8.9A.

### 12. Power Switch

The lamp is powered by AC or a battery source. The 3 position switch rocks to AC POWER and to BATTERY for the Sony V-mount cells. The center rest setting is OFF.

### 13. Sony Type V-mount Battery Docks

The Illumi Max 500 can be powered with 2 Sony V-mount BP series batteries in the docking bays. You must use both bays to operate the light. The output of a single cell should have a maximum output 150W.

### 14. Channel Value Button

Press to alter and set the Channel value. Use the Main Adjustment Wheel to select. The number displays on the LCD panel.

### 15. DMX Button

Press to modify the DMX setting. The DMX data value displays on the panel.

### 16. FUN/SFX Mode Button

Short press to cycle through 5 special effects: F1-Paparazzi; F2-Fireworks; F3 Warning; F4 Thunder; F5-TV.

The Main Adjustment Wheel (15) changes between the brightness and the effect strength with a press.

## 17. LCD Panel

The panel displays the values for Brightness and Channel selection, as well as a light specifying the value selection mode; i.e., Brightness percentage, Channel number, and DMX information.

## 18. Main Adjustment Wheel

The Adjustment Wheel turns in two directions for selecting the value of any selected function.

## 19. Optional connection to 36V power supplies with 3 pin cables.

### Power Box

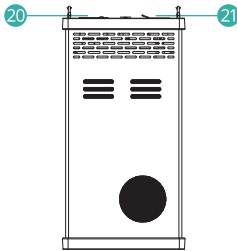

## 20. Line Connection Socket

Connects the Control Box to the Power Box through a 3 pin locking XLR cable to a screw locking 3 pin port.

## 21. Power Cord Socket

Insert the AC/DC switching adapter in this socket. Operates worldwide on AC100-240V ~ 50/60Hz, with an output of DC36V 8.9A. The switch for power option on top of the Control Box should be in the ADAPTER position.

## 22. Light Modifier Lock

Pull back to release the installed Bowens Type-S modifier. Then, twist the modifier counterclockwise to remove.

### Note:

A thermally triggered overheat protection system will automatically shutdown the fixture if internal temperature exceeds 194°F/90°C.

A warning of 15 'click' sounds precedes the shutdown. Normal operation resumes upon completed cooldown.

## Safety Warnings

- The environment should be kept dry and ventilated when using the light. The unit should never be exposed to water and moisture. Take heed when operating outdoors in precipitation.
- Don't stick pointy metal things into the unit.
- Don't attempt to modify the unit yourself. If it becomes damaged, please contact your vendor or take it to an authorized repair service. Do not disassemble this equipment. Touching the product's internals could result in injury. In the event of a malfunction, the product should be repaired only by a qualified technician.
- Make sure you only use accessories of the proper voltage.
- Don't let children play with the unit. Keep the light out of reach from children.
- Severe damage may occur by using near people or animals' eyes. That can cause. Please do not directly look at the illuminated light.
- Should smoke come from the unit, disconnect the power immediately and place it in a safe location. It is normal for the fixture to become warm when working.
- Don't use the light near flammable liquids or vapors, like gasoline.
- If you are packing the light, please triple check that it is turned off.
- After using the light for extended periods, allow it to cool before storing, to avoid damage to the electronic components.
- Don't use the light to support any other equipment or lift your imaging device by the unit.
- Please use the soft dry cloth to clean the light. If necessary, carefully wash with a cloth dampened with neutral detergents, and then dry with a soft cloth.
- Use prudence and attach to a support with the stand adapter.

## Specifications

Attribute	Detail
Power	500W
Color Accuracy / CRI	> 95Ra
Photometrics W/Reflector	.5m: 430,000 lux; 1m: 59,000 lux; 2m: 12,000 lux
Light Source	40mm COB High Power LED Module
Color Temperature	5600°K±200°K
Dimmer Intensity Range	10%-100%
Thermal Control	Smart Active Cooling Fans
Remote Control	Wireless Radio Remote
Remote Frequency	2.4GHz
Remote Channels	99
Remote Range	≥ 164 ft / 50m
DMX512	YES
Battery Type	SONY V-MOUNT BP series battery - ×2 the maximum output of a single battery must be ≥150W continuous draw
Dimensions	Main Light 13.0 × 10.0 × 6.0" / 33.0 × 25.4 × 15.2 cm Power Pack 10.25 × 4.65 × 7.65" / 26.0 × 11.8 × 19.4 cm
Weight	Main Light 6lb 4.1oz / 2.84kg with yoke Power Pack 5lb 11.2oz / 2.58kg
Power Adapter	Input: AC100-240V~50/60Hz Output: DC36V 8.9A

# CLAR Wireless 2.4GHz Remote Control for CLAR Illumi Max Series

## Features

- 2.4 GHz Wireless Remote Control
- Wide range 99 channels for signal purity
- ONE code, 00, as a single global channel for simultaneous control to all CLAR Illumi Max lights
- Ready for action with last setting memory in standby mode
- Controls light intensity from 10-100%
- Varies Color Temperature from 3200°K – 5600°K on Bi-Color models
- Powered by 2 AAA batteries

## Overview

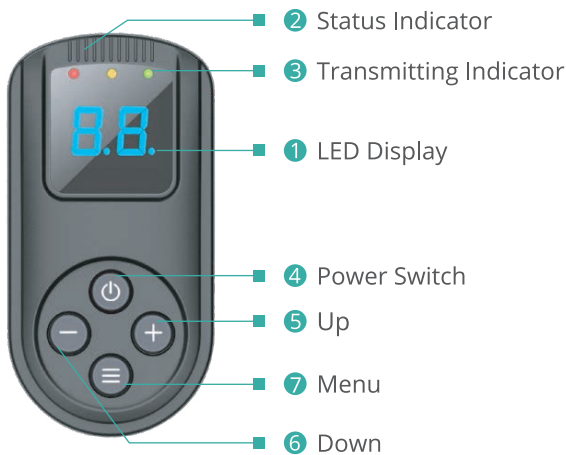

## 1. LED Display

When the display values are in blue numbers, the LED display shows the brightness of the light ranging from 10 (10%) to 99 (99%). When the indicator is orange, the LED display shows the color temperature of the light ranging from 32 (3200°K) to 56 (5600°K), on Bi-Color models.

Brightness: 10-99

Channel Address Values: 00-99

Color Temperature: 32-56 (on Bi-Color models)

Power OFF the light: OFF

## 2. Status Indicator

When the red LED indicator is on, it shows the brightness value.

When the yellow LED indicator is on, it shows color temperature value.

When both LED indicators are off, it shows remote channel address.

When LED indicator flickers, it indicates low battery status.

## 3. Transmitting Indicator

When there is data transmitted, the green LED indicator flickers.

## 4. Power switch

To power off the light: Press the power switch and hold for more than 1 second.

To power on the light: Briefly press the power switch.

The channel address values display after powering on.

When the remote channel value is set to 1-99, only those units with the same values work for remote functions.

It is possible to control all lighting units despite the specific channel assigned to each light, by using the universal value 00. See GLOBAL ILLUMI MAX WIRELESS details below.

## 5. Up Button (plus)

A brief press on the button: the values change upwardly one number at a time.

Long press the button continuously: the values rapidly change upwardly.

The brightness values display through the Menu button. It is possible to control brightness on all lighting units despite the specific channel assigned to each light, by using the universal value 00.

When the remote channel value is set to 1-99, only those units with the same values work for remote brightness functions.

## 6. Down Button (minus)

A brief press on the button: the values change downwardly one number at a time.  
Long press the button continuously: the values rapidly change downwardly.

The brightness values display through the Menu button. It is possible to control brightness on all lighting units despite the specific channel assigned to each light, by using the universal value 00.

When the remote channel value is set to 1-99, only those units with the same values work for remote brightness.

## 7. Menu

The Menu button serves as the master control for scrolling through functions for light intensity as a dimmer and channel values. A short press changes the function. The first in the sequence is Brightness Dimmer (red light), (on Bi-Color models) the second is Color Temperature (yellow) and third is Blend (red and yellow lamp). Press and the menu button briefly to cycle change modes between Dimmer, Color and Channel selection. Long press again to return to the Dimmer mode selections.

1. When powering on, the default setting is the daylight 5600°K mode, the red indicator light is on, indicating Brightness Dimmer mode.
2. In case you find yourself in the Yellow/Color mode or the YellowRed/Blend mode, press and hold the menu button for a few seconds. The red indicator light flickers, indicating a return to the Brightness Dimmer mode. The light will then be able to be controlled once again for the options of channel and dimmer.

## Global ILLUMI MAX Wireless

A unique feature of the Wireless Remote is the assignment of one code, 00, as a single global channel for universal simultaneous control to all the CLAR Illumi Max units. When the master channel is set to <00>, the brightness can be adjusted despite the channel value on the remote device.

## Specifications

Model	CLAR Wireless Remote for Illumi Max Series CLCLSLWRT
Wireless Transmitter	2.4 GHz
Channels	99
Wireless Range	>100ft /30m
Modulation Mode	GFSK
Power Supply	2 AAA 1.5v
Size	3.3 × 1.7 × 1.0" / 83.82 × 43.18 × 25.4mm
Weight	1.6oz / 48g

**Note:** Technical data is subject to change without notice.

## In the Box

- CLAR ILLUMI MAX 500W COB LED fixture
- AC Power Pack with cords
- 15ft Data Cable
- Wireless 2.4GHz Radio Remote Control
- Reflector
- Canvas Compartment Case
- 1 Year CLAR US Warranty

## \*What are COB LEDs?

**Chip On Board, or COB LEDs** are multiple LED chips, bonded directly to a substrate to form a single unified module. The chips can be mounted to take up less space and obtain the highest potential of the LED chip elements. When the COB LED cell energizes, it appears more like a brilliant lighting panel than multiple individual lights, as would be the case when using several SMD LEDs mounted closely together. These diodes form one single module and when turned on, and appear to be one light. Light loss is decreased significantly, and the coverage angle is increased as lenses and other traditional LED encasement parts are no longer necessary in the design of the lamp when using COB LEDs.

MLA: "The Basics Of Chip On Board (cob) LEDs | Digikey."  
<<https://www.digikey.com/en/articles/techzone/2016/aug/the-basics-of-chip-on-board>>.

## One Year CLAR Limited Warranty

CLAR warrants to the original purchaser that your CLAR product shall be free from defects in material and workmanship for the period of one (1) year from the date of purchase (or delivery as may be required in certain jurisdictions), or thirty (30) days after replacement, whichever comes later.

CLAR's entire liability and your exclusive remedy for any breach of warranty shall be, at CLAR's option, to repair or replace the hardware, provided that the hardware is returned to the point of purchase or such other place as CLAR may direct with a copy of the sales receipt or dated itemized receipt. CLAR may, at its option, replace your product, offer to provide a functionally equivalent product, or repair any product with new, refurbished or used parts as long as such parts are in compliance with the product's technical specifications. Any replacement hardware product will be warranted for the remainder of the original warranty period or thirty (30) days, whichever is longer, or for any additional period of time that may be applicable in your jurisdiction. If the product has been discontinued, the warranty provider reserves the right to replace it with a model of equivalent quality and function.

This warranty does not cover problems or damage resulting from accident, abuse, misapplication, or any unauthorized repair, modification or disassembly, improper operation or maintenance, normal wear and tear, or usage not in accordance with product instructions or connection to improper voltage supply, use of consumables, such as replacement batteries, not supplied by CLAR, except where such restriction is prohibited by applicable law.

Except where prohibited by applicable law, this warranty is nontransferable and is limited to the original purchaser and the country in which the product was purchased. This warranty gives you specific legal rights, and you may also have other rights, including a longer warranty duration that may vary under local laws.

To start a warranty claim, contact the CLAR Customer Service Department to obtain a return merchandise authorization ("RMA") number, and return the defective product to CLAR, along with the RMA number and proof of purchase.

## Question about our product line? Need Product Support?

We are proud of our products and celebrate our customers.

We are with you, from product selection to everyday use.

Be secure with your purchase and reach us as you need.

 212-647-9300

 [brands@adorama.com](mailto:brands@adorama.com)

 Adorama Brands,  
42 West 18th Street,  
New York, NY 10011

You can always contact us at [BRANDS@ADORAMA.COM](mailto:BRANDS@ADORAMA.COM)  
for personal technical support.

Our website contains a wide range of Support and FAQ pages  
with valuable technical assistance.

CLAR is a registered trademark of ADORAMA CAMERA.

© 2020 Adorama Camera, Corp.

All Rights Reserved.

CLILMAX500SL

Adorama Inc., New York, NY  
[www.adorama.com/ourbrands](http://www.adorama.com/ourbrands)