

GEFEN EXT-UHD600A-88 USER MANUAL



Quick Links

[Network Configuration Using Syner-G](#)

[Ip Settings](#)

[The Web Interface](#)

[Introduction to the Web Interface](#)

[Using Telnet, Udp, and Rs-232](#)

Table of Contents

[technical support](#)

[packing list](#)

[Table of Contents](#)

[Getting Started](#)

[Introduction](#)

[Front Panel](#)

[Rear Panel](#)

[IR Remote Control](#)

[Installing the Batteries](#)

[Setting the IR Channel](#)

[Installation](#)

[Connection Instructions](#)

[Application Diagram](#)

[Network Configuration using Syner-G](#)

[Powering the Matrix](#)

[Viewing the Routing Status](#)

[Routing Inputs to Outputs](#)

[Using the Front Panel](#)

[Using the IR Remote Control](#)

[Adjusting the Output Volume](#)

[Muting and Unmuting Audio](#)

[Masking Outputs](#)

[Turning Off Inputs](#)

[Locking the Matrix](#)

[Using the IR Remote Control](#)

[Routing Presets](#)

[Using the Front Panel](#)

[Using the IR Remote Control](#)

[Menu System](#)

[Accessing the Menu System](#)

[Audio Output Mode](#)

[HPD Control](#)

[HDCP Control](#)

[Setting the EDID Mode](#)

[IP Settings](#)

[TCP / Telnet Settings](#)

[Discovery Settings](#)

[RS-232 Feedback](#)

[Adjusting the LCM Brightness](#)

[Setting the Matrix IR Channel](#)

[Resetting the Matrix](#)

[Rebooting the Matrix](#)

[The Web Interface](#)

[Introduction to the Web Interface](#)

[Locking the Matrix](#)

[Viewing the Routing Status](#)

[Routing Inputs and Masking Outputs](#)

[Routing Presets](#)

[Input and Output Status](#)

[Changing Input and Output Names](#)

[Audio](#)

[HPD Control](#)

[HDCP](#)

[Setting the EDID Mode](#)

[Copying EDID Data](#)

[Getting EDID Information](#)

[Uploading and Downloading EDID Data](#)

[Configuring Network Settings](#)

[System Settings](#)

[Using Telnet, UDP, and RS-232](#)

[Telnet Configuration](#)

[UDP Configuration](#)

[RS-232 Configuration](#)

[Commands](#)

[Discovery Service](#)

[Input Status](#)

[Manage EDID](#)

[Network Settings](#)

[Output Status](#)

[Presets](#)

[Routing](#)

[Setup](#)

[System Settings](#)

[Volume](#)

[Network Cable Diagram](#)

[Default Settings](#)

[Internal EDID Profiles](#)

[Specifications](#)

[Index](#)

[Other ManualsLib Projects](#)



600 MHz
4K ULTRA HD

8x8 Matrix

w/HDR and Audio De-Embedder

EXT-UHD600A-88

User Manual



Version A1

Important Safety Instructions

1. Read these instructions.
2. Keep these instructions.
3. Heed all warnings.
4. Follow all instructions.
5. Do not use this product near water.
6. Clean only with a dry cloth.
7. Do not block any ventilation openings. Install in accordance with the manufacturer's instructions.
8. Do not install or place this product near any heat sources such as radiators, heat registers, stoves, or other apparatus (including amplifiers) that produce heat.
9. Do not defeat the safety purpose of the polarized or grounding-type plug. A polarized plug has two blades with one wider than the other. A grounding type plug has two blades and a third grounding prong. The wide blade or the third prong are provided for your safety. If the provided plug does not fit into your outlet, consult an electrician for replacement of the obsolete outlet.
10. Protect the power cord from being walked on or pinched particularly at plugs, convenience receptacles, and the point where they exit from the apparatus.
11. Only use attachments/accessories specified by the manufacturer.
12. To reduce the risk of electric shock and/or damage to this product, never handle or touch this unit or power cord if your hands are wet or damp. Do not expose this product to rain or moisture.
13. Unplug this apparatus during lightning storms or when unused for long periods of time.
14. Refer all servicing to qualified service personnel. Servicing is required when the apparatus has been damaged in any way, such as power-supply cord or plug is damaged, liquid has been spilled or objects have fallen into the apparatus, the apparatus has been exposed to rain or moisture, does not operate normally, or has been dropped.
15. Batteries that may be included with this product and/or accessories should never be exposed to open flame or excessive heat. Always dispose of used batteries according to the instructions.

Warranty Information

For the latest warranty coverage information, refer to the Warranty and Return Policy under the Connect section of the Gefen Web site at <http://www.gefen.com/connect/warranty-and-return-policy>

Technical Support

(707) 283-5900 (800) 472-5555
8:00 AM to 5:00 PM Monday - Friday, Pacific Time

Email

support@gefen.com

Web

<http://www.gefen.com>

Mailing Address

Gefen
Core Brands, LLC
c/o Customer Service
1800 S McDowell Blvd
Petaluma, CA 94954 USA

- The information in this manual has been carefully checked and is believed to be accurate. However, Gefen assumes no responsibility for any inaccuracies that may be contained in this manual. In no event will Gefen be liable for direct, indirect, special, incidental, or consequential damages resulting from any defect or omission in this manual, even if advised of the possibility of such damages.
- The technical information contained herein regarding the features and specifications is subject to change without notice.



Important

Cable quality is critical when handling 600 MHz HDMI signals. It is highly recommend that Gefen Locking HDMI cables, 10-foot or shorter, be used in the installation. Gefen HDMI cables have been designed and tested to work at 600 MHz and reliably transport the full 18 Gbps throughput of HDMI 2.0.

© 2017 Core Brands, LLC. All Rights Reserved. All trademarks are the property of their respective owners.

Gefen® is a registered trademark of Core Brands, LLC.

Gefen and Core Brands, LLC reserve the right to make changes in the hardware, packaging, and any accompanying documentation without prior written notice.



This product uses UL-Listed power supplies



This product uses software that is subject to open source licenses, including one or more of the General Public License Version 2 and Version 2.1, Lesser General Public License Version 2.1 and Version 3, BSD, and BSD-style licenses. Distribution and use of this product is subject to the license terms and limitations of liability provided in those licenses. Specific license terms and Copyright Notifications are provided in the source code.

For three years from date of activation of this product, any party may request, and we will supply, for software covered by an applicable license (e.g. GPL or LGPL), a complete machine-readable copy of the corresponding open source code on a medium customarily used for software interchange. The following software and libraries are included with this product and subject to their respective open source licenses:

- lwIP
- jQuery

lwIP is licenced under the BSD licence:

Copyright (c) 2001-2004 Swedish Institute of Computer Science.
All rights reserved.

Redistribution and use in source and binary forms, with or without modification, are permitted provided that the following conditions are met:

1. Redistributions of source code must retain the above copyright notice, this list of conditions and the following disclaimer.
2. Redistributions in binary form must reproduce the above copyright notice, this list of conditions and the following disclaimer in the documentation and/or other materials provided with the distribution.
3. The name of the author may not be used to endorse or promote products derived from this software without specific prior written permission.

THIS SOFTWARE IS PROVIDED BY THE AUTHOR "AS IS" AND ANY EXPRESS OR IMPLIED WARRANTIES, INCLUDING, BUT NOT LIMITED TO, THE IMPLIED WARRANTIES OF MERCHANTABILITY AND FITNESS FOR A PARTICULAR PURPOSE ARE DISCLAIMED. IN NO EVENT SHALL THE AUTHOR BE LIABLE FOR ANY DIRECT, INDIRECT, INCIDENTAL, SPECIAL, EXEMPLARY, OR CONSEQUENTIAL DAMAGES (INCLUDING, BUT NOT LIMITED TO, PROCUREMENT OF SUBSTITUTE GOODS OR SERVICES; LOSS OF USE, DATA, OR PROFITS; OR BUSINESS INTERRUPTION) HOWEVER CAUSED AND ON ANY THEORY OF LIABILITY, WHETHER IN CONTRACT, STRICT LIABILITY, OR TORT (INCLUDING NEGLIGENCE OR OTHERWISE) ARISING IN ANY WAY OUT OF THE USE OF THIS SOFTWARE, EVEN IF ADVISED OF THE POSSIBILITY OF SUCH DAMAGE.

Features*

- Routes eight 4K sources to eight 4K displays
- Supports resolutions up to 4K Cinema-DCI (4096 x 2160 up to 60 Hz, 4:4:4), 4K Ultra HD (3860 x 2160 up to 60 Hz, 4:4:4) with HDR, 1080p Full HD, and WUXGA (1920x1200)
- Supports HDCP 2.2 and 1.4
- Supports HDR (High Dynamic Range) 10-bit Deep Color at 4K 60 Hz 4:2:0 and 4K 24 Hz 4:4:4
- Supports 12-bit Deep Color at 1080p Full HD (60 Hz 4:4:4)
- 3DTV pass-through
- Lip Sync pass-through
- EDID Management for rapid integration of source and displays
- Supports uncompressed LPCM digital audio up to 7.1 channels
- Supports up to 7.1 channels of HBR (High Bit Rate) digital audio including Dolby Atmos®, Dolby® TrueHD, DTS:X™, and DTS-HD Master Audio™
- Supports the use of DVI sources and DVI displays up to 1080p Full HD and WUXGA (1920x1200), with Gefen CAB-DVI2-HDMI-LCK DVI-to-HDMI cables (not included)
- Built-in Audio De-Embedders break out 2 channel analog, 2 channel PCM, and up to 5.1 channels of Bitstream digital audio from each HDMI output, allowing the audio content to be sent to external amplifiers and music distribution systems for added impact.
- Enhanced API facilitates added functionality with third-party control systems.
- Easy-to-read, super-bright OLED front panel display indicates routing status and IP settings
- Locking power connector
- Push button controls for Routing and Status
- RS-232 Serial control interface for use with a third-party controller
- IP control via Telnet, UDP, and the built-in web server interface
- IR remote control
- Gefen Syner-G™ software simplifies initial IP configuration and EDID Management
- Field-updatable firmware via web server interface
- 2 U tall enclosure
- Removable rack ears come pre-installed
- Can be placed on a shelf or mounted in a standard 19-inch wide rack

* Features and specifications are subject to change without notice.

Packing List

The 4K Ultra HD 600 MHz 8x8 Matrix w/ HDR and Audio De-Embedder ships with the items listed below. If any of these items are not present in the box when you first open it, immediately contact your reseller or Gefen Technical Support.

- 1 x 4K Ultra HD 600 MHz 8x8 Matrix
- 1 x 24V DC Power Supply (EXT-PS24U-O-6)
- 1 x AC Power Cord
- 4 x Self-Adhesive Rubber-Feet (pre-attached)
- 1 x IR Extender (EXT-RMT-EXTIRN)
- 1 x IR Remote (RMT-88A)
- 2 x AAA Batteries for the remote
- 1 x Quick-Start Guide

1 Getting Started

Introduction.....	2
Front Panel.....	2
Rear Panel.....	3
IR Remote Control.....	5
Installing the Batteries.....	8
Setting the IR Channel.....	9
Installation.....	10
Connection Instructions.....	10
Application Diagram.....	11
Network Configuration using Syner-G.....	12

2 Basic Operation

Powering the Matrix.....	16
Viewing the Routing Status.....	17
Routing Inputs to Outputs.....	18
Using the Front Panel.....	18
Using the IR Remote Control.....	20
Adjusting the Output Volume.....	21
Muting and Unmuting Audio.....	23
Masking Outputs.....	25
Turning Off Inputs.....	26
Locking the Matrix.....	27
Using the IR Remote Control.....	28
Routing Presets.....	29
Using the Front Panel.....	29
Using the IR Remote Control.....	30
Menu System.....	31
Accessing the Menu System.....	31
Audio Output Mode.....	33
HPD Control.....	35
HDCP Control.....	37
Setting the EDID Mode.....	40
IP Settings.....	43
TCP / Telnet Settings.....	48
Discovery Settings.....	56
RS-232 Feedback.....	58
Adjusting the LCM Brightness.....	60
Setting the Matrix IR Channel.....	62
Resetting the Matrix.....	64
Rebooting the Matrix.....	66
The Web Interface.....	68
Introduction to the Web Interface.....	68
Locking the Matrix.....	73
Viewing the Routing Status.....	74

Routing Inputs and Masking Outputs	75
Routing Presets.....	78
Input and Output Status	81
Changing Input and Output Names.....	82
Audio	83
HPD Control	84
HDCP	85
Setting the EDID Mode	87
Copying EDID Data.....	89
Getting EDID Information.....	91
Uploading and Downloading EDID Data.....	92
Configuring Network Settings.....	95
System Settings	101

3 Advanced Operation

Using Telnet, UDP, and RS-232	112
Telnet Configuration.....	112
UDP Configuration	112
RS-232 Configuration.....	113
Commands.....	114
Discovery Service	114
Input Status	114
Manage EDID.....	114
Network Settings	115
Output Status	116
Presets	116
Routing.....	116
Setup.....	117
System Settings	117
Volume.....	117

4 Appendix

Network Cable Diagram	208
Default Settings.....	209
Internal EDID Profiles.....	210
Specifications	215
Index.....	217

This page left intentionally blank.

This page left intentionally blank.

600 MHz
4K ULTRA HD

8x8 Matrix

w/HDR and Audio De-Embedder

1 Getting Started

Front Panel

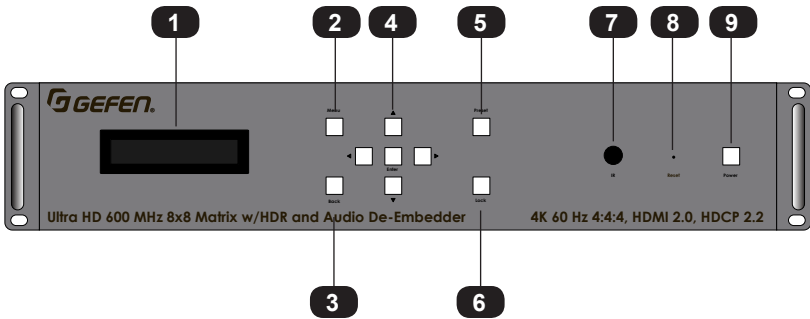

ID	Name	Description
1	Front panel display	Displays matrix settings and feedback during operation.
2	Menu	Used to access the internal menu system. See Accessing the Menu System (page 31) for more information.
3	Back	Press this button to step return to a previous menu item.
4	▲, ▼, ◀, ▶, Enter	Use the cursor buttons to select the desired item within the menu system. Press the Enter button to confirm the selection. See Accessing the Menu System (page 31) for more information.
5	Preset	Press this button to select the desired Preset.
6	Lock	Press this button to lock the matrix. See Locking the Matrix (page 73) for more information.
7	IR	Receives signals from the included IR remote control unit.
8	Reset	Press and hold this button for 10 seconds, then release, to reset the matrix to factory-default settings.
9	Power	Press this button to power-ON or Power-OFF the matrix.

Rear Panel

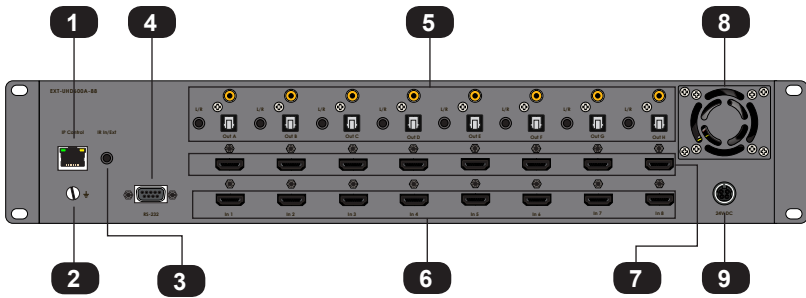

ID	Name	Description
1	IP Control	Connect an Ethernet cable between this jack and a LAN. See Connection Instructions (page 10) for more information.
2	Grounding terminal	Connect a grounding wire (16 AWG or greater) from this terminal to an approved ground path.
3	IR In / Ext	Connect an IR extender (Gefen part no. EXT-RMT-EXTIRN) or an electrical IR cable from an automation system to this port.
4	RS-232	Connect the RS-232 cable from this port to an RS-232 device. See Connection Instructions (page 10) for more information.
5	Audio Outputs	Each HDMI output provides a three separate ports for audio de-embedding: 1) L/R (analog), 2) coax (digital), 3) TOSLINK® (digital).
6	In (1 - 8)	Connect up to eight 4K Ultra HD source devices to the matrix using these HDMI ports.
7	Out (A - H)	Connect up to eight 4K Ultra HD displays to the matrix using these HDMI ports.

ID	Name	Description
8	Cooling fan assembly	Provides active cooling for the matrix by expelling warm air from the enclosure. To prevent overheating, make sure this vent is not blocked.
9	24V DC	Connect the included 24V DC power supply to this power connector.

IR Remote Control



ID	Name	Description
1	Output buttons (A - H)	Press these buttons to select the desired input when performing routing operations. Each button corresponds to an Out port (A - H) on the rear panel of the matrix.
2	Menu	Press this button to display the On-Screen Menu.
3	▲, ▼, ◀, ▶	Press these buttons to move around within the front panel display.
4	Back	Press this button to return to a previous menu item.

ID	Name	Description
5	Input buttons (1 - 8)	Press these buttons to select the desired input when performing routing operations. Each button corresponds to an In port (1 - 8) on the rear panel of the matrix.
6	Off	Press this button to block an input. See Turning Off Inputs (page 26) for more information.
7	Lock	Press this button to toggle between locking and unlocking the buttons on the front panel.
8	OK	Press this button to accept the current selection in the menu system.
9	Preset	Press this button to select the desired preset. See Routing Presets (page 78) for more information.
10	Mask	Press this button to mask the desired output.
11	Volume	Adjusts the output volume on the selected output. See Adjusting the Output Volume (page 21) for more information.
12	Mute	Press this button to mute the audio on the selected output. See Muting and Unmuting Audio (page 23) for more information.
13	Power	Press this button to toggle power on the matrix.
14	DIP switches	Sets the IR channel of the IR remote control. In order for the IR remote control to communicate with the matrix, both the IR remote control and the matrix must be set to the same IR channel. See Setting the IR Channel (page 9) for information on setting the IR channel of the IR remote control. Use the front panel controls to set the IR channel of the matrix. See Setting the Matrix IR Channel (page 62) for information on setting the IR channel of the matrix.

ID	Name	Description
15	Battery compartment (shown open)	Press this button to toggle between locking and un Accepts two 1.5V AAA-type batteries. See Installing the Batteries (page 8) for more information.

Installing the Batteries

1. Remove the back cover the IR remote control unit.
2. Insert two 1.5V AAA-type batteries, as shown, within the battery compartment.

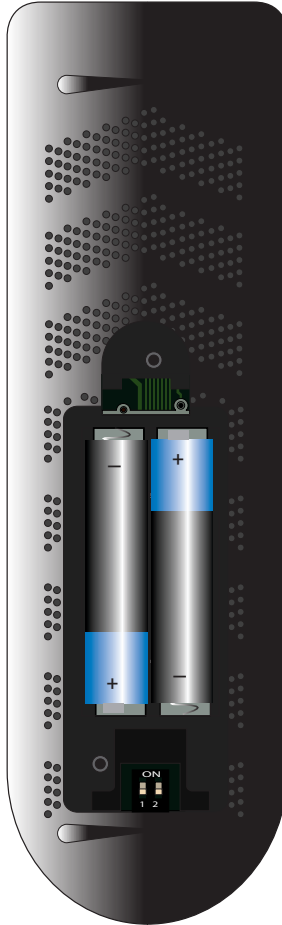

3. Replace the back cover.



Warning!

Risk of explosion if battery is replaced by an incorrect type. Dispose of used batteries according to the instructions.

Setting the IR Channel

Use the following DIP switch settings to set the IR channel of the IR remote control. In order for the included IR remote control to communicate with the matrix, the IR remote control must be set to the same channel as the matrix.

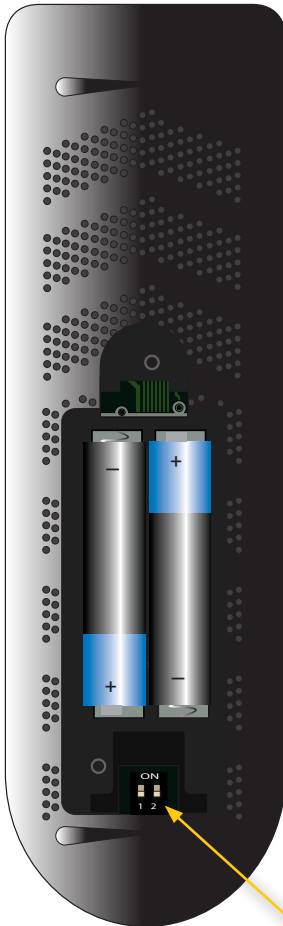

Channel 1 (default):

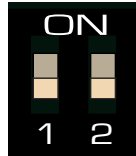

DIP1 = OFF
DIP2 = OFF

Channel 2:



DIP1 = ON
DIP2 = OFF

Channel 3:



DIP1 = OFF
DIP2 = ON

Channel 4:

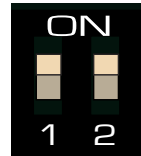

DIP1 = ON
DIP2 = ON

DIP switches

Connection Instructions

▶ Video

1. Connect an HDMI cable from each 4K Ultra HD source device to the **In** ports (1 - 8) on the rear panel of the matrix. Up to eight source devices can be connected.
2. Connect a 4K Ultra HD display to each of the **Out** ports (A - H) on the rear panel of the matrix. Up to eight displays can be connected.

▶ Audio De-embedding

3. The matrix provides one analog and two digital outputs for each HDMI output for audio de-embedding:
 - a. Connect a 3.5mm mini-stereo cable from each **L/R** port to an A/V receiver.
 - b. Connect a RCA cable from each coax port to an A/V receiver.
 - c. Connect an optical cable from each TOSLINK® port to an A/V receiver.

▶ IP Control

4. Connect a shielded CAT-5e (or better) cable from the IP Control port on the rear panel of the matrix to the Local Area Network. See [Network Configuration using Syner-G \(page 12\)](#) for more information on configuration.

▶ RS-232 (optional)

5. Connect a DB-9 cable from the RS-232 port on the rear panel of the matrix to the automation device. See [RS-232 Configuration \(page 113\)](#) for more information.

▶ IR Control (Optional)

6. Connect an IR extender (Gefen part no. EXT-RMT-EXTIRN) or an electrical IR cable from an automation system to the **IR In / Ext** port on the rear panel of the matrix. Connecting an IR extender is useful if the IR sensor on the front panel will be hidden from view.

▶ Power

7. Connect the included 24V DC power supply to the power connector on the matrix.
8. Connect the AC power cord to the power supply and connect the power cord to an available electrical outlet.

Application Diagram

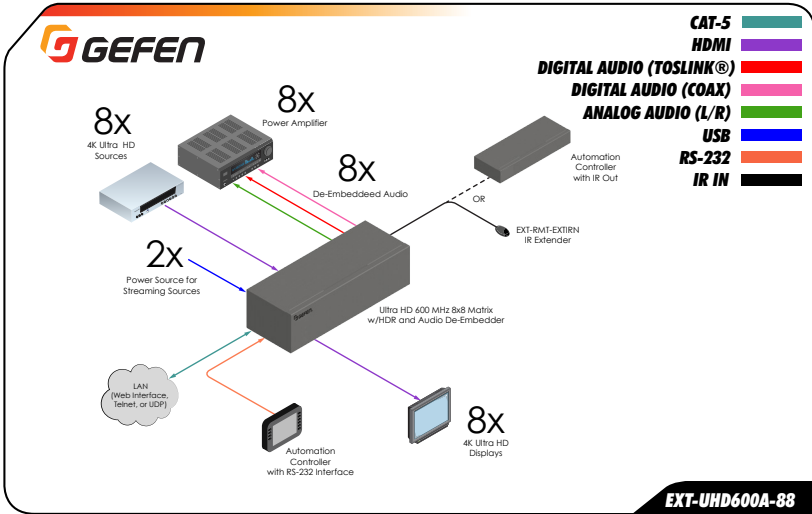

Network Configuration using Syner-G

1. Launch the Gefen Syner-G application.
Download the application here: <http://www.gefen.com/support/download.jsp>
2. Select the matrix (EXT-UHD600A-88) from the list of products.

Discover	Configure	Manage EDID	Update
My PC	10.5.64.90	00:1D:09:7E:E1:1F	Loc
Product Name	IP Address	MAC Address	
EXT-UHD600A-88	192.168.0.172	00:1C:91:04:D0:04	EXT
EXT-MFP	10.5.64.52	00:1C:91:04:50:05	EXT
GEF-UHDA-88-HBT2	10.5.64.181	00:1C:91:04:90:21	GEF
EXT-CU-LAN	10.5.64.151	00:1C:91:04:60:17	EXT

3. Under the Device Settings section, select either Static or DHCP from the IP Mode drop-down list.
 - ▶ Select **Static** to manual enter the IP address, subnet mask, and gateway IP. Consult with your network administrator, if necessary.
 - ▶ Select **DHCP** to let the DHCP server automatically assign the IP address, subnet mask, and gateway IP.

Device Settings		
EXT-UHD600A-88	IP Mode	Static
00:1C:91:04:D0:04	Web GUI Port	Static DHCP Auto
0.5.64.205	Telnet Port	23
55.255.255.0	Firmware Version	V1.0B
0.5.64.1	Hardware Version	V1.0
	Description	EXT-UHD600A-88

- Click the **Save** button at the bottom of the screen.

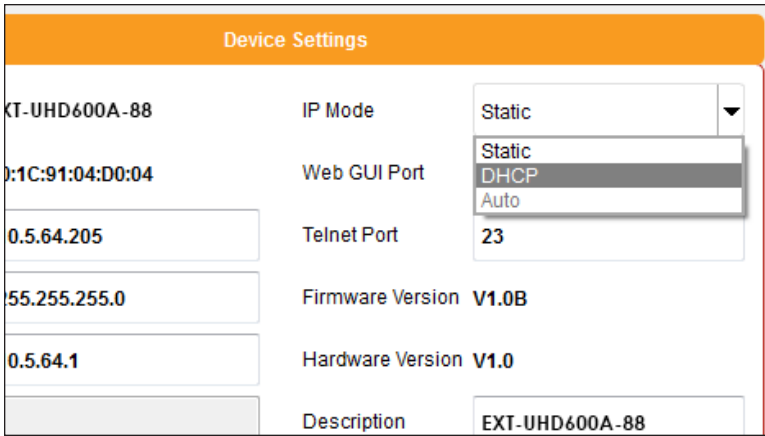

Device Settings		
KT-UHD600A-88	IP Mode	Static
08:1C:91:04:D0:04	Web GUI Port	Static DHCP Auto
0.5.64.205	Telnet Port	23
55.255.255.0	Firmware Version	V1.0B
0.5.64.1	Hardware Version	V1.0
	Description	EXT-UHD600A-88

- The matrix will automatically reboot and use the new network settings.
- Use the IP address of the matrix to access the built-in web interface or start a Telnet session. See the following for more information:
 - ▶ [The Web Interface \(page 68\)](#)
 - ▶ [Using Telnet, UDP, and RS-232 \(page 112\)](#)

This page left intentionally blank.

600 MHz
4K ULTRA HD

8x8 Matrix

w/HDR and Audio De-Embedder

2 Basic Operation

Powering the Matrix

Use the **Power** button to power-on and power-off the matrix. The **Power** button is located on the front panel of the matrix and on the IR remote control.

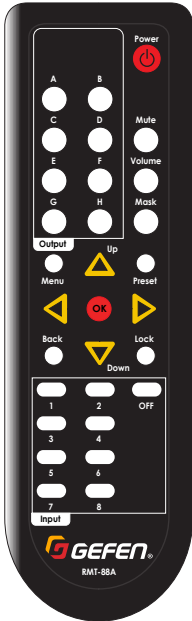
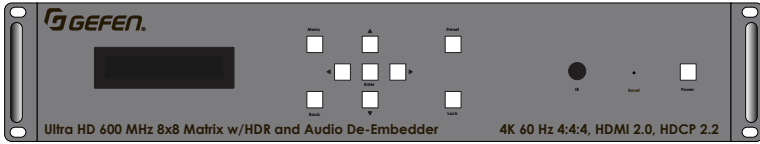

1. Connect the included power supply from the power connector to an available electrical AC outlet. The **Power** button will glow solid red, indicating that the matrix is connected to an active outlet. However, the matrix is not turned on.

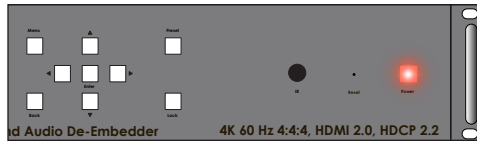

2. Press the **Power** button on the front panel or on the IR remote control.
3. The **Power** button on the front panel will glow solid blue to indicate that the matrix is powered.

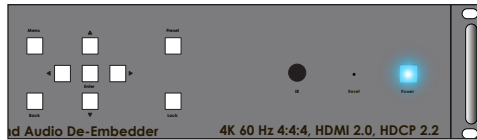

The first piece of information that is displayed is the model and current firmware. Be sure to check the Gefen website for the latest version of firmware.



4. After a few moments, the *routing screen* will be displayed. The *routing screen* represents the "home" screen from which the built-in menu system can be accessed.



Viewing the Routing Status

1. Go to the *routing screen*. If the routing screen is not displayed, then press the **Back** button on the front panel or on the IR remote control until the *routing screen* is displayed.

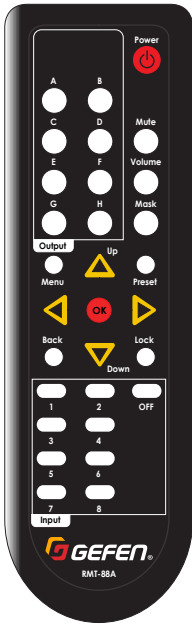
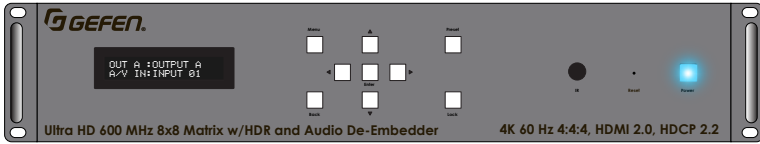

In the example below, the source that is connected to **In 1** is currently routed to the display (sink device) that is connected to **Out A**.

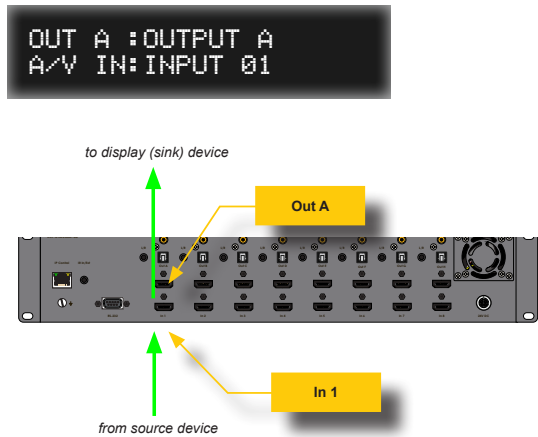

2. Press and release the **▲** or **▼** buttons on the front panel or on the IR remote control to view each output and which input is being received.

The **▲** or **▼** buttons, on the front panel, will momentarily glow blue when pressed, as shown below:

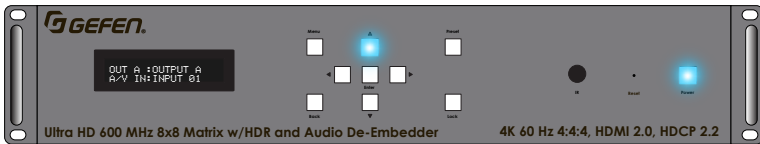

When the matrix is shipped from the factory, the matrix is set to “one-to-one” routing mode. This means that Input 1 is routed to Output A, Input 2 is routed to Output B, Input 3 is routed to Output C, and so on. To change the routing state for any output, follow the instructions below.

Using the Front Panel

1. Go to the *routing screen*. If the routing screen is not displayed, then press and release the **Back** button until the *routing screen* is displayed.

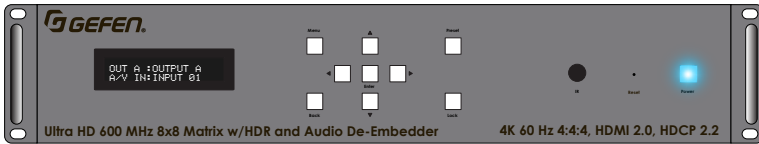

2. Select the desired output by pressing and releasing the **▲** or **▼** buttons. These buttons will glow blue when they are pressed.

Example: We have a 4K Ultra HD source connected to **In 4** (Input 4) and we want to view the source on the 4K Ultra HD display that is connected to **Out G** (Output G).

The first thing we need to do is use the **▲** or **▼** buttons until Output G is displayed. Currently, Input 7 is routed to Output G. We need to change it to Input 4.



3. Press the **Enter** button.
4. An arrow cursor will be displayed next to the input. This indicates that input can now be changed.



5. Press and release the ▲ or ▼ buttons to select the desired input. In this example, we will select Input 4.

```
OUT G :OUTPUT G
>A/V IN:INPUT 04
```

6. Once the desired input is selected, press the **Enter** button. The arrow cursor, next to the input, will disappear indicating that the input can not be changed.

```
OUT G :OUTPUT G
A/V IN:INPUT 04
```

7. The selected input is now routed to the selected output.
8. Repeat steps 2 - 6 to change the routing state for additional outputs.

Using the IR Remote Control



Information

The front panel display will only show activity if a routing operation is being performed on the output that is displayed. Otherwise, the routing operation is performed in the background. To verify that the new routing state has been executed, you can view the current routing state for that output. See [Viewing the Routing Status](#) (page 17) for more information.

1. Go to the *routing screen*. If the routing screen is not displayed, then press and release the **Back** button on the IR remote control until the *routing screen* is displayed.
2. Select the desired output by pressing one of the Output buttons (A - H) on the top-portion of the IR remote control. In this example, we will route Input 5 to Output D.

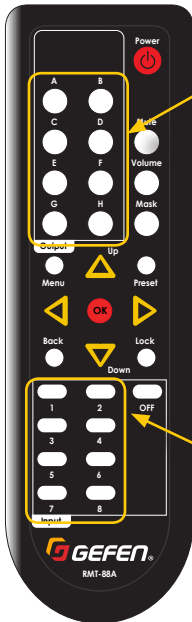

Output buttons

3. Select the desired input by pressing one of the Input buttons (1 - 8) on the lower-portion of the IR remote control.

```
OUT D : OUTPUT D
A/V IN : INPUT 02
```

4. The routing process is complete.

Down button

```
OUT D : OUTPUT D
A/V IN : INPUT 05
```

Adjusting the Output Volume

The output volume of each output can be adjusted from either the front panel, using the included IR remote, or through the built-in web interface. In order to adjust the volume, the audio output mode of the matrix must be set to *variable*. See [Audio Output Mode \(page 33\)](#) for more information.

1. Go to the *routing screen*. If the routing screen is not displayed, then press the **Back** button on the front panel or on the IR remote control until the *routing screen* is displayed.

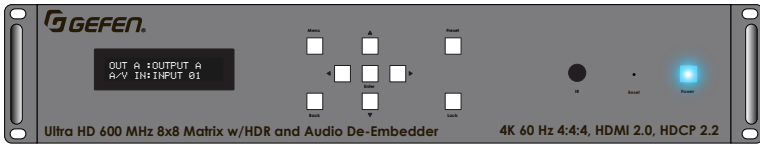

2. Press the **Volume** button on the IR remote control. The front panel display will prompt for the output to be adjusted.

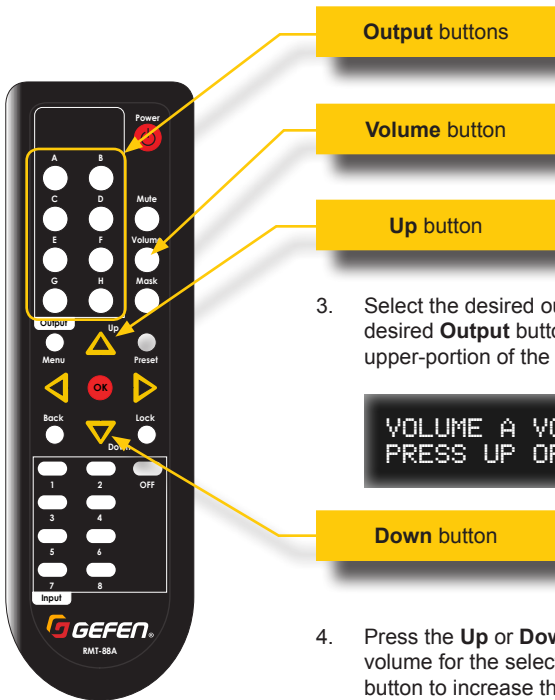

3. Select the desired output by pressing the desired **Output** button (A - H) on the upper-portion of the IR remote control.



4. Press the **Up** or **Down** button to adjust the volume for the selected output. Press the **Up** button to increase the volume. Press the **Down** button to decrease the volume.



Information

If the **Down** arrow button is pressed when the volume level is set to 0, then the volume will be returned to 100. Similar behavior exists if the volume level is set to 100 and the **Up** arrow is pressed: the volume level will be set to 0.

5. Press the **Back** button to accept the volume setting for the selected output and return to the **Volume Select Output** screen.



VOLUME
SELECT OUTPUT

6. Select another output using the **Output** buttons or press the **Back** button a second time to return to the routing screen.



OUT B : OUTPUT B
A/V IN: INPUT 02

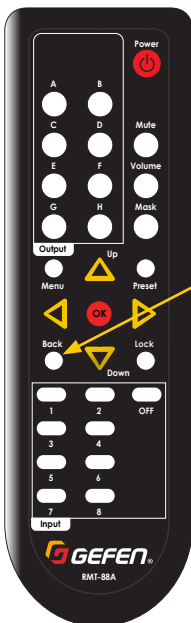

Back button

Muting and Unmuting Audio

The audio for each output can be muted from either the front panel, using the included IR remote, or through the built-in web interface. The **Mute** button is used for both muting and unmuting audio on the desired output.

1. Go to the *routing screen*. If the routing screen is not displayed, then press the **Back** button on the front panel or on the IR remote control until the *routing screen* is displayed.

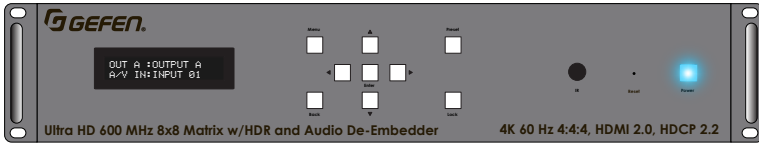

2. Press the **Mute** button on the IR remote control. The front panel display will prompt for the output to be adjusted.

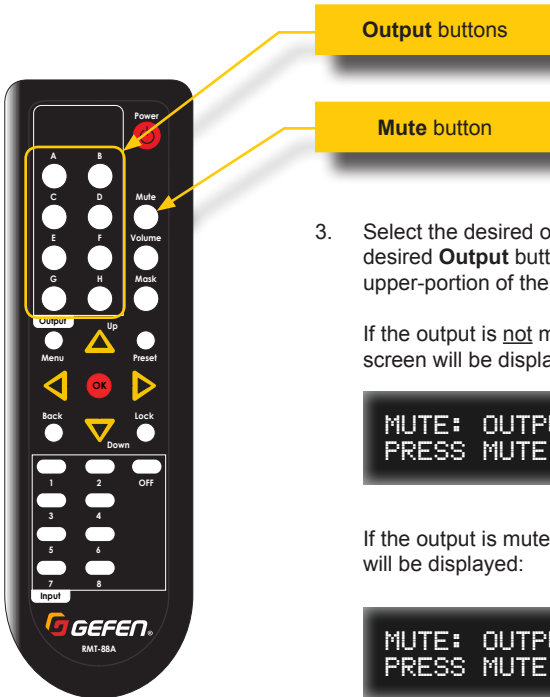

3. Select the desired **Output** button (A - H) on the upper-portion of the IR remote control.

If the output is not muted, then the following screen will be displayed:



If the output is muted, then the following screen will be displayed:



- Press the **Back** button to accept the volume setting for the selected output and return to the **Mute Select Output** screen.

```
MUTE
SELECT OUTPUT
```

- Select another output using the **Output** buttons or press the **Back** button a second time to return to the routing screen.

```
OUT B : OUTPUT B
A/V IN: INPUT 02
```

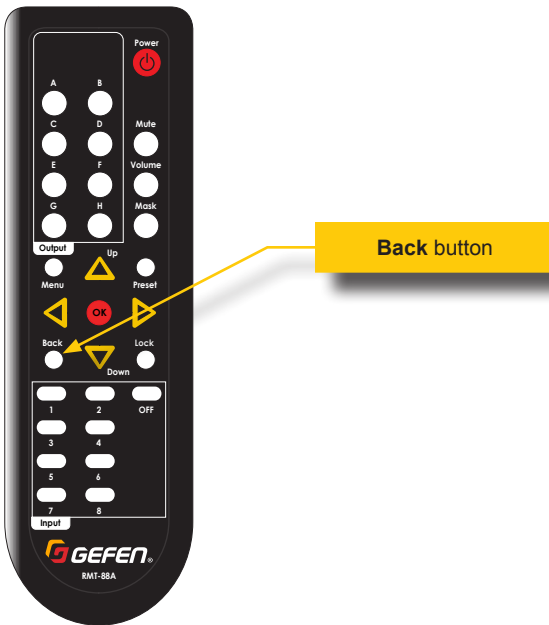

Masking Outputs

When masking outputs through the front panel, the IR remote control *must* be used. Outputs can also be masked by using the built-in web interface. See [Routing Inputs and Masking Outputs \(page 75\)](#) for more information.

When an output is masked, the signal is blocked at the output. Let's say **Input 02** is routed to **Output A**, **Output B**, and **Output C**. If we mask **Output B**, then only A/V signal on **Output B** will be blocked. **Output A** and **Output C** will remain unaffected.

1. Start from any screen. In this example, we are starting at the *routing screen*.



2. Press the **Mask** button on the IR remote control.
3. Select the desired output by pressing one of the **Output** buttons (A - H) on the top-portion of the IR remote control.
4. The selected output will be masked immediately.
5. To unmask the the desired output, repeat steps 2 and 3.

Information

When an output is masked, no feedback will be shown on the front-panel display. However, the built-in web interface will always reflect a masking change.

Turning off an input simulates a source that is not present.

Setting an input to the OFF state can only be performed through the IR remote control or the built-in web interface. See [Routing Inputs to Outputs \(page 18\)](#) for more information.

1. Starting from any screen, press the button of the output (**Local, A - H**), on the top-portion of the IR remote control, where the **Input** is routed.

For example, if we want to “block” **Input 3**, and **Input 3** is routed to **Output H**, then we would press the **H** button.

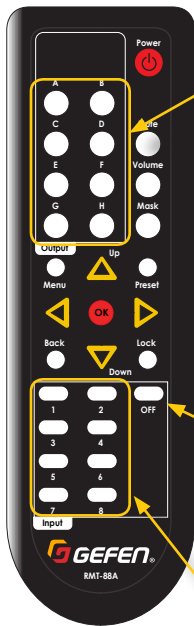

2. Press the **Off** button on the IR remote control.
3. The selected input will be turned “off” immediately.
4. The front-panel display will show the change:



In order for an input, on the matrix, to be turned “off”, a source device must be connected to the input.

5. To “unlock” an input, press the desired **Output** button (A - H) then select an input from the **Input** buttons, located at the bottom-portion of the IR remote control.

To prevent an accidental routing change or power-down (by pressing the **Power** button), the front-panel buttons on the matrix can be locked. Locking the matrix disables the front-panel controls, IR, and the built-in web interface.

▶ Locking the Matrix

1. Starting from any screen, press and hold the **Lock** button.
2. The **Lock** button will flash blue six times and then glow solid blue.
3. Release the Lock button.
4. The matrix is now locked.

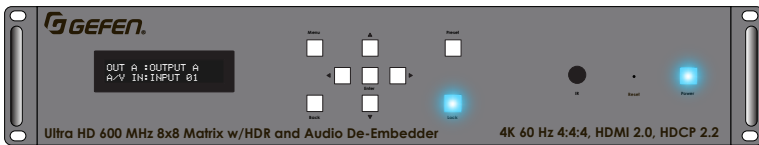

▶ Unlocking the Matrix

1. To unlock the matrix, press and hold the Lock button.
2. The Lock button will flash six times and then will be no longer illuminated.
3. The matrix is now unlocked.

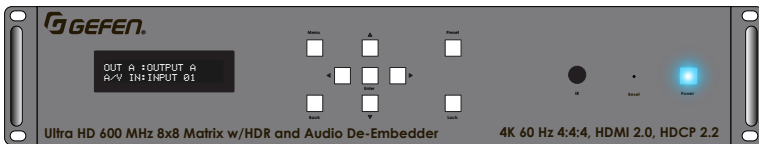

Using the IR Remote Control

▶ Locking the Matrix

1. Starting from any screen, press the **Lock** button on the IR remote control.

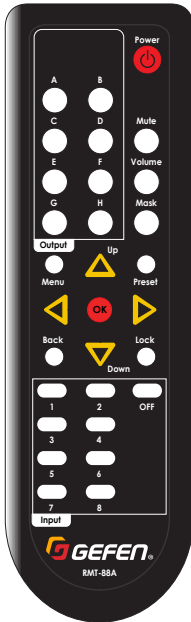

2. The **Lock** button on the front panel will glow solid blue.
3. The matrix is now locked.

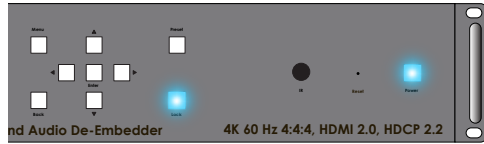

▶ Unlocking the Matrix

1. To unlock the matrix, press the Lock button on the IR remote control.
2. The Lock button, on the front panel, will be no longer illuminated.
3. The matrix is now unlocked.

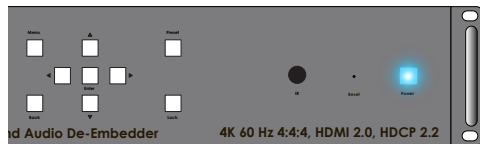

Routing presets can be recalled using the front panel buttons or the IR remote control. For information on creating presets, see [Routing Presets \(page 29\)](#).

Using the Front Panel

1. Start from any screen.
2. Press the **Preset** button on the front panel. The **Preset** button, on the front panel, will flash blue when pressed.

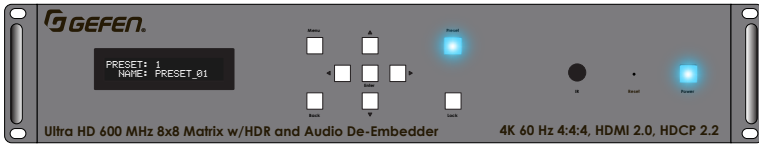

3. The **Preset** selection screen will be displayed.



4. Select the desired preset by pressing and releasing the ▲ or ▼ buttons on the front panel.



5. Once the desired preset is selected, press the **Enter** button on the front panel to load the preset.



6. The preset is now loaded and the routing state, stored in the preset, will be applied to the matrix.
7. After a few moments, the routing screen will be displayed.



Using the IR Remote Control

1. Start from any screen.
2. Press the **Preset** button on the IR remote control.

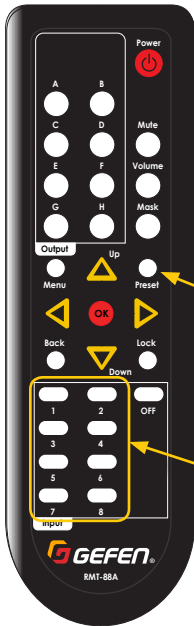

3. Use the set of **Input** buttons, from the bottom-portion of the IR remote control to select the desired preset.

Only Presets 1 - 8 can be selected, when using the IR remote control.

4. The preset is now loaded and the routing state, stored in the preset, will be applied to the matrix.

Preset button

Input buttons



Information

When using the IR remote control, no confirmation will be shown in the front panel display.

Accessing the Menu System

The front-panel menu system provides the ability to locally control many of the matrix features. However, we recommend using the built-in Web interface to control the matrix. For more information on accessing the web interface, see [The Web Interface \(page 68\)](#).

1. Go to the *routing screen*. If the routing screen is not displayed, then press the **Back** button on the front panel or on the IR remote control until the *routing screen* is displayed.

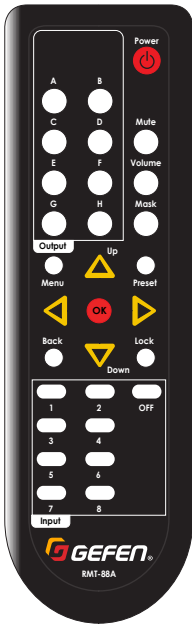
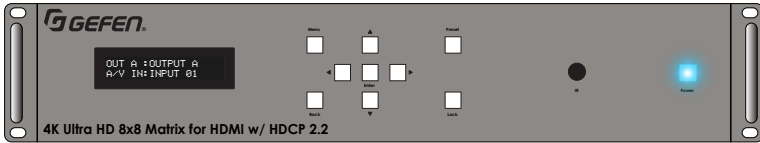

2. Press and release the **Menu** button on the front panel or on the IR remote control. The **Menu** button will momentarily flash blue when it is pressed.

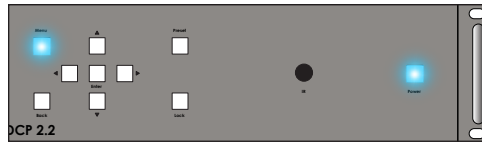

3. The **Setup** menu will be displayed:



There are four menu systems: **Setup**, **EDID Management**, **Network**, and **System**. The **Setup** menu will always be the first menu to be displayed, when entering the menu system.

4. Press and release the **▲** or **▼** buttons to select the desired menu. These buttons will glow blue when they are pressed.

5. The top-level menu system has the following order:

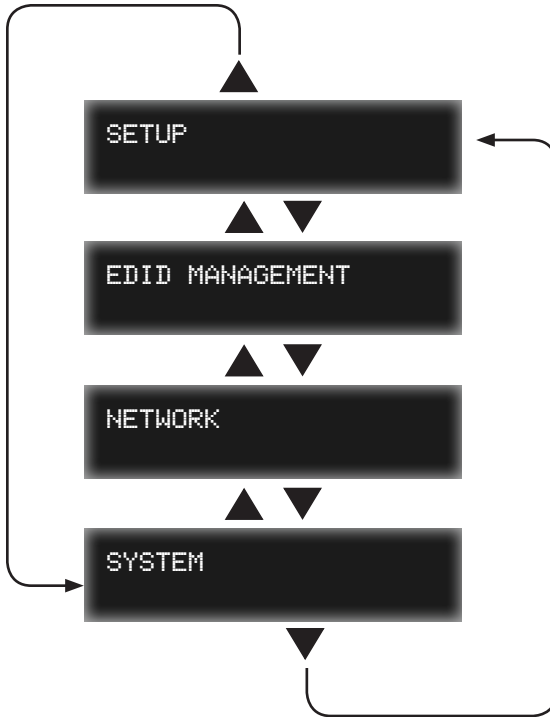

6. To return to the *routing screen*, press the **Back** button on the front panel or on the IR remote control until the *routing screen* is displayed.

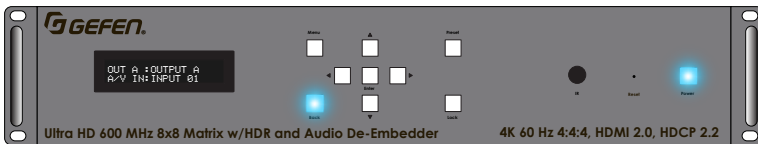

Information

Depending upon the location within the menu system, multiple presses of the **Back** button may be required in order to return to the routing screen.

Audio Output Mode

This menu option allows the audio output to be set to either variable or fixed. If set to `fixed`, then the matrix will control the audio output. If set to `var` (variable), then the output volume will be controlled by the source.

1. Go to the *routing screen*. If the *routing screen* is not displayed, then press the **Back** button on the front panel or on the IR remote control until the *routing screen* is displayed.



2. Press and release the **Menu** button on the front panel or on the IR remote control. The **Menu** button, on the front panel, will momentarily flash blue when it is pressed.

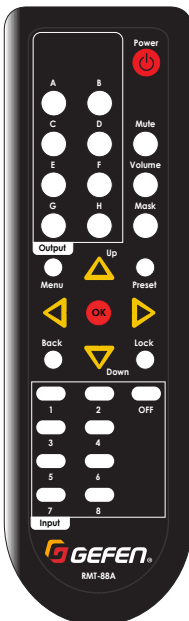
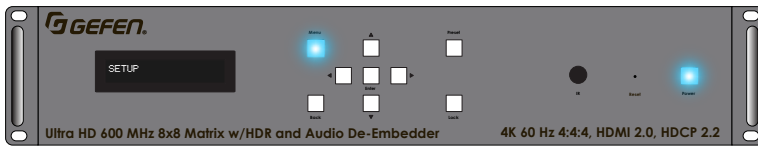

3. The **Setup** menu will be displayed:



4. Press the **Enter** button on the front panel. If using the included IR remote control, press the **OK** button.
5. The **Audio Output Mode** option will be displayed:



6. Press and release the **▲** or **▼** buttons on the front panel or on the included IR remote control, to select the desired output.

7. Once the desired output is selected, press the **Enter** button on the front panel or the **OK** button on the IR remote control. The arrow cursor will appear next to the current selection for the output.

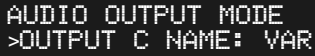

```
AUDIO OUTPUT MODE
>OUTPUT C NAME: VAR
```

8. Press and release the **▲** or **▼** buttons on the front panel or on the IR remote control, to select the desired setting.



```
AUDIO OUTPUT MODE
>OUTPUT C NAME: FIXED
```

9. Press the **Enter** button on the front panel or the **OK** button on the IR remote control to save the setting.
10. To set the volume control on a different output, press the **Back** button on the front panel or on the IR remote control, then repeat steps 6 - 8.
11. To return to the routing screen, press the **Back** button twice.

HPD Control

This menu option allows an HPD (Hot-Plug Detect) pulse to be sent to the selected input. Sending an HPD pulse to an input is equivalent to disconnecting and reconnecting the video cable at the source.

1. Go to the *routing screen*. If the *routing screen* is not displayed, then press the **Back** button on the front panel or on the IR remote control until the *routing screen* is displayed.



2. Press and release the **Menu** button on the front panel or on the IR remote control. The **Menu** button, on the front panel, will momentarily flash blue when it is pressed.

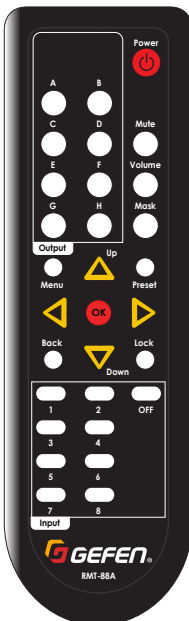
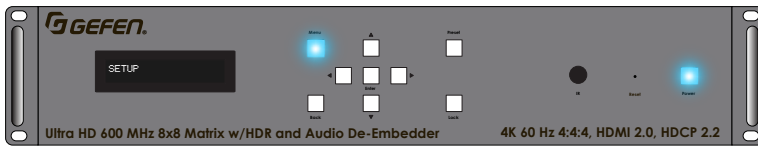

3. The **Setup** menu will be displayed:



4. Press the **Enter** button on the front panel. If using the included IR remote control, press the **OK** button.
5. The **HPD Control** option will be displayed:



6. Press the **Enter** button on the front panel. If using the included IR remote control, press the **OK** button.

- The input selection screen will be displayed. **Input 01** will be displayed, by default.



```
HDP CONTROL:
PULSE: INPUT 01
```

- Press and release the ▲ or ▼ buttons on the front panel or on the IR remote control, to select the desired input. These buttons will glow blue when they are pressed on the front panel.
- After selecting the desired input, press the **Enter** button on the front panel. If using the included IR remote control, press the **OK** button.

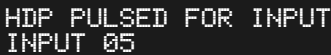

```
HDP PULSED FOR INPUT
INPUT 05
```

- The HPD pulse will be sent to the selected input. If a display is connected to the output to which the input is routed, then the display will flash as the HPD pulse is received.
- After a few moments, the input selection screen will be displayed again:



```
HDP CONTROL:
PULSE: INPUT 05
```

- To send an HPD pulse to another input, repeat steps 4 - 7.
- To return to the **HPD Control** option, press the **Back** button on the front panel or on the IR remote control.
- To return to the routing screen, press the **Back** button two more times.

HDCP Control

This menu option restricts the version of HDCP that is accepted by an input. This matrix supports up to HDCP 2.2.

1. Go to the *routing screen*. If the routing screen is not displayed, then press the **Back** button on the front panel or on the IR remote control until the *routing screen* is displayed.
2. Press and release the **Menu** button on the front panel or on the IR remote control. The **Menu** button, on the front panel, will momentarily flash blue when it is pressed.

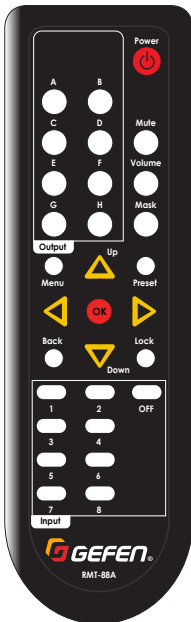
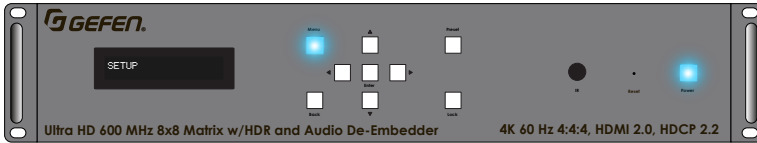

2. The **Setup** menu will be displayed:



3. Press the **Enter** button on the front panel. If using the included IR remote control, press the **OK** button.
4. The **HPD Control** option will be displayed:



5. Press and release the **▲** or **▼** buttons on the front panel or on the IR remote control, to select the **HDCP Control** option:



6. Press the **Enter** button on the front panel or on the IR remote control to display the input control screen.

- Press the **Enter** button on the front panel or on the IR remote control to display the input control screen.

```
HDCP CONTROL: INPUT
INPUT 01: 2.2
```

- Press and release the **▲** or **▼** buttons on the front panel or on the included IR remote control, to select the desired input or output. These buttons will glow blue when they are pressed on the front panel.

```
HDCP CONTROL: INPUT
INPUT 03: 2.2
```

- Press the **Enter** button on the front panel. If using the included IR remote control, press the **OK** button.

If an input (1 - 8) is selected, then the following options will be available:

- ▶ **2.2 and below**
Only HDCP version 2.2 and below is allowed to be sent from the source device.
- ▶ **1.4 and below**
Only HDCP version 1.4 and below is allowed to be sent from the source device.
- ▶ **Reject**
Blocks HDCP content from being sent from the source device.

If an output (A - H) is selected, then the following options will be available:

- ▶ **Follow Input**
HDCP pass-through: The content on the output of the matrix matches the content provided by the source device.
- ▶ **Always Encode**
Always applies HDCP encryption to the content on the output of the matrix. So, even if the source is not HDCP, the output will be HDCP.

- Once the desired input or output is selected, press the **Enter** button on the front panel or the **OK** button on the IR remote control. The arrow cursor will appear next to the current selection for the input (or output).

```
INPUT 03
>2.2 AND BELOW
```

11. Press and release the ▲ or ▼ buttons on the front panel or on the IR remote control, to select the desired setting.



INPUT 03
>1.4 AND BELOW

12. Press the **Enter** button on the front panel or the **OK** button on the IR remote control to save the setting.



INPUT 03
1.4 AND BELOW

13. To set the HDCP control on a different input or output, press the **Back** button on the front panel or on the IR remote control.
14. To return to the **HPD Control** option, press the **Back** button on the front panel or on the IR remote control.
15. To return to the routing screen, press the **Back** button two more times.

Setting the EDID Mode

This menu option allows the EDID that will be used by the source that is connected to each input. Internal, external, or a custom EDID can be selected.

1. Go to the *routing screen*. If the routing screen is not displayed, then press the **Back** button on the front panel or on the IR remote control until the *routing screen* is displayed.
2. Press and release the **Menu** button on the front panel or on the IR remote control. The **Menu** button, on the front panel, will momentarily flash blue when it is pressed.

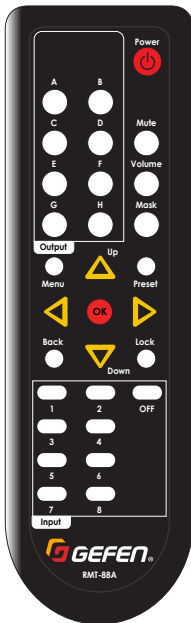
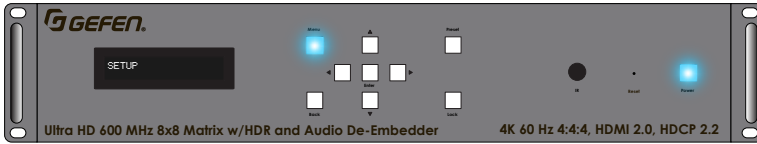

2. The **Setup** menu will be displayed:



3. Press and release the **▲** or **▼** buttons on the front panel or on the IR remote control, to select the **EDID Management** menu:



4. Press the **Enter** button on the front panel. If using the included IR remote control, press the **OK** button.

5. The **EDID Mode** menu will be displayed:



- Press the **Enter** button on the front panel or on the IR remote control to display the input control screen. **Input 01** will be displayed by default.



```
EDID MODE
INPUT 01
```

- Press and release the **▲** or **▼** buttons on the front panel or on the IR remote control, to select the desired input.



```
EDID MODE
INPUT 05
```

- Press the **Enter** button on the front panel. If using the included IR remote control, press the **OK** button.
- The EDID selection screen will be displayed. The current EDID, for the selected input, will be displayed. An arrow cursor will be displayed next to the current EDID, indicating that it can be changed.



```
EDID: INPUT 05
>1080P 2CH
```

- Press and release the **▲** or **▼** buttons on the front panel or on the IR remote control, to select the desired EDID. See [Internal EDID Profiles \(page 210\)](#) for details on internal EDID specifications.

The available EDID options, for each input, are:

EDID	Description
UHD 4K 600 MHz 2Ch	UHD 4K 600 Mhz with 2-channel audio
UHD 4K 600 MHz Multi	UHD 4K 600 Mhz with multichannel audio
UHD 4K 300 MHz 2Ch	UHD 4K 300 Mhz with 2-channel audio
UHD 4K 300 MHz Multi	UHD 4K 300 Mhz with multichannel audio
1080P 2Ch	1080p with 2-channel audio
1080P Multi	1080p with multichannel audio
External	Uses EDID of downstream sink
Custom - User	Uses a custom EDID

See [Setting the EDID Mode \(page 87\)](#) for more information on using the Custom setting.

11. Once the desired EDID has been selected, press the **Enter** button on the front panel or the **OK** button on the IR remote control. The input selection screen will be displayed.



12. To set the EDID on another input, repeat steps 7 - 11.
13. Press the **Back** button on the front panel or on the IR remote control to return to the **EDID Mode** menu.
14. To return to the routing screen, press the **Back** button two more times.

IP Settings

Use this menu option to set the IP mode, IP address, subnet mask, gateway, and HTTP port of the matrix.

1. Go to the *routing screen*. If the routing screen is not displayed, then press the **Back** button on the front panel or on the IR remote control until the *routing screen* is displayed.
2. Press and release the **Menu** button on the front panel or on the IR remote control. The **Menu** button, on the front panel, will momentarily flash blue when it is pressed.

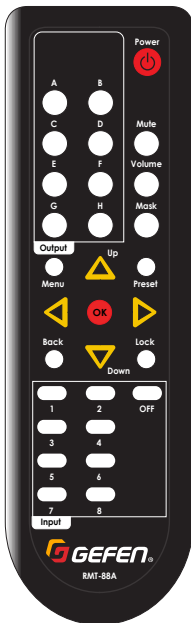
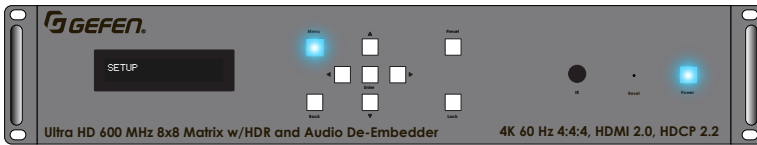

2. The **Setup** menu will be displayed:



3. Press and release the **▲** or **▼** buttons on the front panel or on the IR remote control, to select the **Network** menu:



4. Press the **Enter** button on the front panel. If using the included IR remote control, press the **OK** button.

5. The **IP Settings** menu will be displayed:

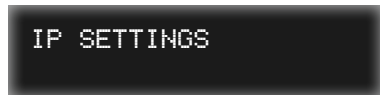

6. Press the **Enter** button on the front panel or the **OK** button on the IR remote control to display the **IP Mode** screen. The current network mode will be displayed.

▶ Setting the IP Mode

- a. From the **IP Mode** screen, press the **Enter** button on the front panel or the **OK** button on the IR remote control. An arrow cursor will be displayed next to the current IP mode, indicating that it can be changed:

```
IP MODE:
>STATIC
```

- b. Press and release the **▲** or **▼** buttons on the front panel or on the IR remote control, to select the desired IP Mode.

▶ **Static mode**

Allows custom configuration of the IP address, subnet mask, and gateway.

▶ **DHCP mode**

The IP address, subnet mask, and gateway address are automatically assigned by a DHCP server.

- c. Press the **Enter** button on the front panel or the **OK** button on the IR remote control to save the change.
- d. Reboot the matrix to affect changes.

▶ Setting the IP Address

- a. From the **IP Mode** screen, press and release the **▲** or **▼** buttons on the front panel or on the IR remote control, to select the **IP Address** option. The current IP address will be displayed.

```
IP ADDRESS
192.168.001.072
```

- b. Press the **Enter** button on the front panel or the **OK** button on the IR remote control to edit the IP address.



Important

The IP address can only be changed if the IP Mode is set to Static.

- c. The cursor will appear under the first digit of the IP address.

```
IP ADDRESS
_192.168.001.072
```

- d. Press the ▲ or ▼ buttons on the front panel or on the IR remote control, to change the numerical value of the digit (0 - 9).



IP ADDRESS:
092.168.001.072

- e. Press the ◀ or ▶ buttons on the front panel or on the IR remote control to move between each digit in the IP address.
- f. After the desired IP address has been set, press the **Enter** button on the front panel or the **OK** button on the IR remote control to save the change.



IP ADDRESS:
010.005.064.001

- g. Reboot the matrix to affect changes.

▶ Setting the Subnet Mask

- a. From the **IP Mode** screen, press and release the ▲ or ▼ buttons on the front panel or on the IR remote control, to select the **Subnet Mask** option. The current subnet mask will be displayed.



SUBNET MASK:
255.255.255.000

- b. Press the **Enter** button on the front panel or the **OK** button on the IR remote control to edit the IP address.



Important

The subnet mask can only be changed if the IP Mode is set to Static.

- c. The cursor will appear under the first digit of the address.



SUBNET MASK:
255.255.255.000

- d. Press the ◀ or ▶ buttons on the front panel or on the IR remote control to move between each digit in the address.

- a. Press the ▲ or ▼ buttons on the front panel or on the IR remote control, to change the numerical value of the digit (0 - 9).

```
SUBNET MASK:
255.255.055.000
```

- b. After the desired address has been set, press the **Enter** button on the front panel or the **OK** button on the IR remote control to save the change.

```
SUBNET MASK:
255.255.000.000
```

- c. Reboot the matrix to affect changes.

► Setting the Gateway

- a. From the **IP Mode** screen, press and release the ▲ or ▼ buttons on the front panel or on the IR remote control, to select the **Gateway** option. The current gateway address will be displayed.

```
GATEWAY:
192.168.001.001
```

- b. Press the **Enter** button on the front panel or the **OK** button on the IR remote control to edit the address.



Important

The gateway address can only be changed if the IP Mode is set to Static.

- c. The cursor will appear under the first digit of the address.

```
GATEWAY:
192.168.001.001
```

- d. Press the ▲ or ▼ buttons on the front panel or on the IR remote control, to change the numerical value of the digit (0 - 9).

```
GATEWAY:
092.168.001.001
```

- e. Press the ◀ or ▶ buttons on the front panel or on the IR remote control to move between each digit in the IP address.
- f. After the desired IP address has been set, press the **Enter** button on the front panel or the **OK** button on the IR remote control to save the change.



GATEWAY:
010.005.064.001

- g. Reboot the matrix to affect changes.

▶ Setting the HTTP Listening Port

- a. From the **IP Mode** screen, press and release the ▲ or ▼ buttons on the front panel or on the IR remote control, to select the **HTTP Port** option. The current HTTP port will be displayed.



WEB PORT:
80

- b. Press the **Enter** button on the front panel or the **OK** button on the IR remote control to edit the port number. The cursor will appear under the first digit of the port number.



WEB PORT:
00080

- c. Press the ▲ or ▼ buttons on the front panel or on the IR remote control, to change the numerical value of the digit (0 - 9).
- d. Press the ◀ or ▶ buttons on the front panel or on the IR remote control to move between each digit in the port number.
- e. After the desired address has been set, press the **Enter** button on the front panel or the **OK** button on the IR remote control to save the change.



WEB PORT:
81

- f. Reboot the matrix to affect changes.

TCP / Telnet Settings

Use this menu option to set TCP access, the TCP port, Telnet welcome message state, and enabling / disabling of password credentials.

1. Go to the *routing screen*. If the routing screen is not displayed, then press the **Back** button on the front panel or on the IR remote control until the *routing screen* is displayed.
2. Press and release the **Menu** button on the front panel or on the IR remote control. The **Menu** button, on the front panel, will momentarily flash blue when it is pressed.

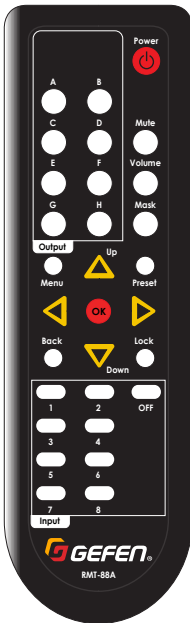
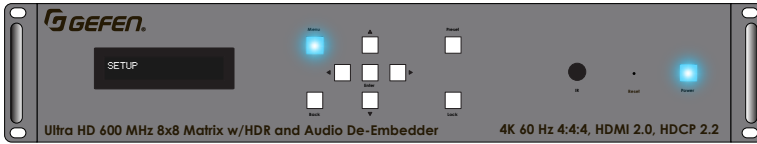

2. The **Setup** menu will be displayed:



3. Press and release the **▲** or **▼** buttons on the front panel or on the IR remote control, to select the **Network** menu:

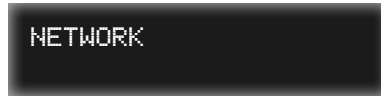

4. Press the **Enter** button on the front panel. If using the included IR remote control, press the **OK** button.
5. Press the **▲** or **▼** buttons on the front panel or on the IR remote control to select the **TCP / Telnet Settings** menu.



6. Press the **Enter** button on the front panel or the **OK** button on the IR remote control to display the **TCP access** screen. The current setting will be displayed.

▶ **Enabling / Disabling TCP (Telnet) Access**

- a. From the **TCP access** screen, press the **Enter** button on the front panel or the **OK** button on the IR remote control.



```
TCP ACCESS:
ENABLED
```

- b. Press the **Enter** button on the front panel or the **OK** button on the IR remote control to change the current setting. An arrow cursor will be displayed next to the current setting, indicating that it can be changed:



```
TCP ACCESS:
>ENABLED
```

- c. Press and release the **▲** or **▼** buttons on the front panel or on the IR remote control, to select the desired setting.

- ▶ **Enabled**
Allows Telnet sessions to the matrix.
- ▶ **Disabled**
Disables Telnet sessions to the matrix.



```
TCP ACCESS:
>DISABLED
```

- d. Press the **Enter** button on the front panel or the **OK** button on the IR remote control to save the change.



```
TCP ACCESS:
DISABLED
```

- e. Reboot the matrix to affect changes.

► **Setting the TCP Listening Port**

- a. From the **TCP access** screen, press and release the ▲ or ▼ buttons on the front panel or on the IR remote control, to select the **TCP Port** option. The current TCP port will be displayed.



TCP PORT:
23

- b. Press the **Enter** button on the front panel or the **OK** button on the IR remote control to edit the port number. The cursor will appear under the first digit of the port number.



TCP PORT:
_00023

- c. Press the ◀ or ▶ buttons on the front panel or on the IR remote control to move between each digit in the port number.
- d. Press the ▲ or ▼ buttons on the front panel or on the IR remote control, to change the numerical value of the digit (0 - 9).



TCP PORT:
00023

- e. After the desired port number has been set, press the **Enter** button on the front panel or the **OK** button on the IR remote control to save the change.



TCP PORT:
00024

- f. Reboot the matrix to affect changes.

► **Enabling / Disabling Telnet Welcome Message**

- a. From the **TCP access** screen, press and release the ▲ or ▼ buttons on the front panel or on the IR remote control, to select the **Telnet Welcome** option. The current setting will be displayed. The default setting is *show*.

```
TELNET WELCOME :  
SHOW
```

- b. Press the **Enter** button on the front panel or the **OK** button on the IR remote control to change the current setting. The cursor will appear next to the current setting.

```
TELNET WELCOME  
>SHOW
```

- c. Press and release the ▲ or ▼ buttons on the front panel or on the IR remote control, to select the desired setting.

► **Show**

Shows the welcome message at the beginning of each Telnet session.

► **Hide**

Hides the welcome message for Telnet sessions.

```
TELNET WELCOME  
>HIDE
```

- d. Press the **Enter** button on the front panel or the **OK** button on the IR remote control to save the change.

```
TELNET WELCOME  
HIDE
```

- e. Reboot the matrix to affect changes.

► **Enabling / Disabling UDP Access**

- a. From the **UDP access** screen, press the **Enter** button on the front panel or the **OK** button on the IR remote control. An arrow cursor will be displayed next to the current setting, indicating that it can be changed:



```
UDP ACCESS:
DISABLED
```

- b. Press the **Enter** button on the front panel or the **OK** button on the IR remote control to change the current setting. The cursor will appear next to the current setting.



```
UDP ACCESS:
>DISABLED
```

- c. Press and release the **▲** or **▼** buttons on the front panel or on the IR remote control, to select the desired setting.

► **Enabled**

Allows the UDP protocol to be used with the matrix.

► **Disabled**

Prevents the UDP protocol from being used with the matrix.



```
UDP ACCESS:
>ENABLED
```

- d. Press the **Enter** button on the front panel or the **OK** button on the IR remote control to save the change.

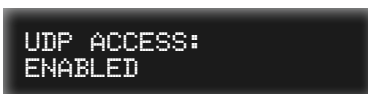

```
UDP ACCESS:
ENABLED
```

- e. Reboot the matrix to affect changes.

► **Setting the UDP Listening Port**

- a. From the **UDP Access** screen, press and release the ▲ or ▼ buttons on the front panel or on the IR remote control, to select the **UDP Port** option. The current UDP port will be displayed.



```
UDP PORT:
50007
```

- b. Press the **Enter** button on the front panel or the **OK** button on the IR remote control to edit the port number. The cursor will appear under the first digit of the port number.



```
UDP PORT:
_50007
```

- c. Press the ◀ or ▶ buttons on the front panel or on the IR remote control to move between each digit in the port number.
- d. Press the ▲ or ▼ buttons on the front panel or on the IR remote control, to change the numerical value of the digit (0 - 9).



```
UDP PORT:
5000_9
```

- e. After the desired port number has been set, press the **Enter** button on the front panel or the **OK** button on the IR remote control to save the change.



```
UDP PORT:
50009
```

- f. Reboot the matrix to affect changes.

► **Enabling / Disabling Remote UDP Access**

- a. From the **UDP Access** screen, press and release the **▲** or **▼** buttons on the front panel or on the IR remote control, to select the **Remote UDP Access** option. The current setting will be displayed.



```
REMOTE UDP ACCESS:  
DISABLED
```

- b. Press the **Enter** button on the front panel or the **OK** button on the IR remote control to change the current setting. The cursor will appear next to the current setting.



```
REMOTE UDP ACCESS:  
>DISABLED
```

- c. Press and release the **▲** or **▼** buttons on the front panel or on the IR remote control, to select the desired setting.

► **Enabled**

Allows the Remote UDP protocol to be used with the matrix.

► **Disabled**

Prevents the Remote UDP protocol from being used with the matrix.



```
REMOTE UDP ACCESS:  
>ENABLED
```

- d. Press the **Enter** button on the front panel or the **OK** button on the IR remote control to save the change.



```
REMOTE UDP ACCESS:  
ENABLED
```

- e. Reboot the matrix to affect changes.

► **Setting the Remote UDP Address**

- a. From the **UDP Access** screen, press and release the **▲** or **▼** buttons on the front panel or on the IR remote control, to select the **Remote UDP Address** option. The current UDP address will be displayed.



```
REMOTE UDP ADDRESS:  
192.168.001.255
```

- b. Press the **Enter** button on the front panel or the **OK** button on the IR remote control to edit the IP address.
- c. The cursor will appear under the first digit of the UDP address.



```
REMOTE UDP ADDRESS:  
192.168.001.255
```

- d. Press the **▲** or **▼** buttons on the front panel or on the IR remote control, to change the numerical value of the digit (0 - 9).



```
REMOTE UDP ADDRESS:  
192.168.001.155
```

- e. Press the **◀** or **▶** buttons on the front panel or on the IR remote control to move between each digit in the IP address.
- f. After the desired UDP address has been set, press the **Enter** button on the front panel or the **OK** button on the IR remote control to save the change.



```
REMOTE UDP ADDRESS:  
192.168.001.155
```

- g. Reboot the matrix to affect changes.

Discovery Settings

Use this menu option to enable / disable the “discovery” feature.

1. Go to the *routing screen*. If the routing screen is not displayed, then press the **Back** button on the front panel or on the IR remote control until the *routing screen* is displayed.
2. Press and release the **Menu** button on the front panel or on the IR remote control. The **Menu** button, on the front panel, will momentarily flash blue when it is pressed.

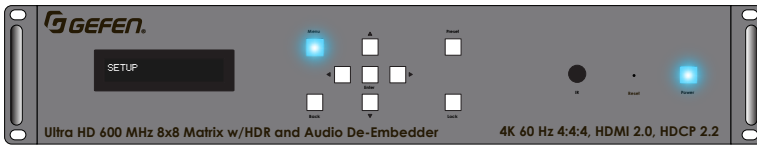

2. The **Setup** menu will be displayed:



3. Press and release the **▲** or **▼** buttons on the front panel or on the IR remote control, to select the **Network** menu:



4. Press the **Enter** button on the front panel. If using the included IR remote control, press the **OK** button.
5. Press the **▲** or **▼** buttons on the front panel or on the IR remote control to select the **Discovery Settings** menu.



6. Press the **Enter** button on the front panel or the **OK** button on the IR remote control to display the **Discovery** screen. The current setting will be displayed.

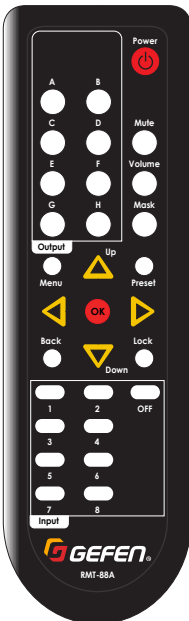

7. Press the **Enter** button on the front panel or the **OK** button on the IR remote control to change the current setting. The cursor will appear next to the current setting.



```
DISCOVERY:  
>ENABLED
```

8. Press and release the **▲** or **▼** buttons on the front panel or on the IR remote control, to select the desired setting.

▶ **Enabled**

Allows the matrix to be “discovered”, when connected to a network, by the Syner-G Software Suite.

▶ **Disabled**

Prevents the matrix from being “discovered” by the Syner-G Software Suite.



```
DISCOVERY:  
>DISABLED
```

9. Press the **Enter** button on the front panel or the **OK** button on the IR remote control to save the change.



```
DISCOVERY:  
DISABLED
```

10. Reboot the matrix to affect changes.

RS-232 Feedback

Use this menu option to enable / disable RS-232 feedback. When *disabled*, RS-232 commands will be executed but will not provide a response.

1. Go to the *routing screen*. If the routing screen is not displayed, then press the **Back** button on the front panel or on the IR remote control until the *routing screen* is displayed.
2. Press and release the **Menu** button on the front panel or on the IR remote control. The **Menu** button, on the front panel, will momentarily flash blue when it is pressed.

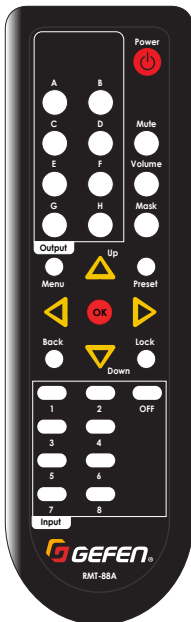
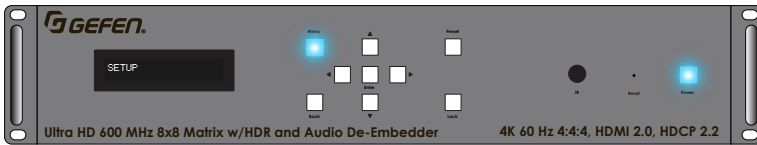

3. The **Setup** menu will be displayed:



4. Press and release the **▲** or **▼** buttons on the front panel or on the IR remote control, to select the **System** menu:



5. Press the **Enter** button on the front panel. If using the included IR remote control, press the **OK** button.
6. Press the **▲** or **▼** buttons on the front panel or on the IR remote control to select the **RS-232 Feedback** menu.

The current setting will be displayed.

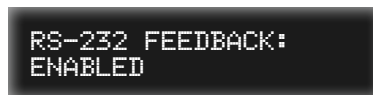

7. Press the **Enter** button on the front panel or the **OK** button on the IR remote control to change the current setting. The cursor will appear next to the current setting.



```
RS-232 FEEDBACK:  
>ENABLED
```

8. Press and release the **▲** or **▼** buttons on the front panel or on the IR remote control, to select the desired setting.

▶ **Enabled**

RS-232 commands are executed and a response is sent back to the automation device.

▶ **Disabled**

RS-232 commands are executed but no response is provided.



```
RS-232 FEEDBACK:  
>DISABLED
```

9. Press the **Enter** button on the front panel or the **OK** button on the IR remote control to save the change.



```
RS-232 FEEDBACK:  
DISABLED
```

10. Reboot the matrix to affect changes.

Adjusting the LCM Brightness

Use this menu option to change the brightness of the front panel LCM display.

1. Go to the *routing screen*. If the routing screen is not displayed, then press the **Back** button on the front panel or on the IR remote control until the *routing screen* is displayed.
2. Press and release the **Menu** button on the front panel or on the IR remote control. The **Menu** button, on the front panel, will momentarily flash blue when it is pressed.

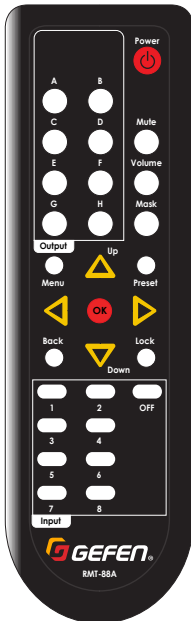
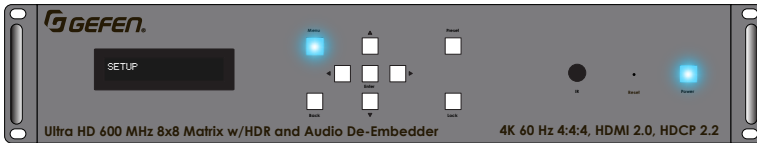

3. The **Setup** menu will be displayed:



4. Press and release the **▲** or **▼** buttons on the front panel or on the IR remote control, to select the **System** menu:



5. Press the **Enter** button on the front panel. If using the included IR remote control, press the **OK** button.
6. Press the **▲** or **▼** buttons on the front panel or on the IR remote control to select the **LCD Brightness** menu.

The current setting will be displayed.



7. Press the **Enter** button on the front panel or the **OK** button on the IR remote control to change the current setting. The cursor will appear next to the current setting.



LCD BRIGHTNESS:
>60

8. Press and release the **▲** or **▼** buttons on the front panel or on the IR remote control, to select the desired setting. The range is from 0 to 100 and can be adjusted by increments of 1.



LCD BRIGHTNESS:
>70

9. Press the **Enter** button on the front panel or the **OK** button on the IR remote control to save the change.



LCD BRIGHTNESS:
70

10. Reboot the matrix to affect changes.

Setting the Matrix IR Channel

Use this menu option to set the IR channel of the matrix. In order for the included IR remote to work with the matrix, both the matrix and the IR remote control must be set to the same IR channel. See [Setting the IR Channel \(page 9\)](#) for more information on setting the IR channel for the IR remote control.

1. Go to the *routing screen*. If the routing screen is not displayed, then press the **Back** button on the front panel or on the IR remote control until the *routing screen* is displayed.
2. Press and release the **Menu** button on the front panel or on the IR remote control. The **Menu** button, on the front panel, will momentarily flash blue when it is pressed.

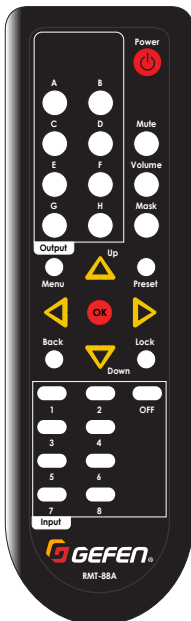
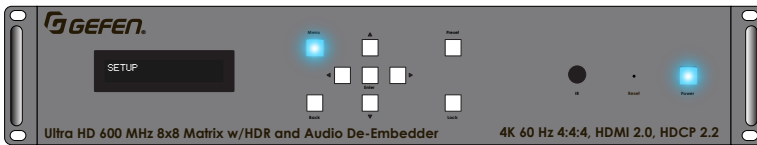

3. The **Setup** menu will be displayed:



4. Press and release the **▲** or **▼** buttons on the front panel or on the IR remote control, to select the **System** menu:



5. Press the **Enter** button on the front panel. If using the included IR remote control, press the **OK** button.
6. Press the **▲** or **▼** buttons on the front panel or on the IR remote control to select the **IR Channel** menu.

The current IR channel will be displayed.

7. Press the **Enter** button on the front panel or the **OK** button on the IR remote control to change the current IR channel. The cursor will appear next to the current IR channel.



```
IR CHANNEL:
>1
```

8. Press and release the **▲** or **▼** buttons on the front panel or on the IR remote control, to select the desired IR channel. The IR channel range is 1 - 4.



```
IR CHANNEL:
>2
```

9. Press the **Enter** button on the front panel or the **OK** button on the IR remote control to save the change.



```
IR CHANNEL:
2
```

10. Reboot the matrix to affect changes.

Resetting the Matrix

Use this menu option to reset the matrix to factory-default settings. See [Default Settings \(page 209\)](#) for more information on these settings.

1. Go to the *routing screen*. If the routing screen is not displayed, then press the **Back** button on the front panel or on the IR remote control until the *routing screen* is displayed.
2. Press and release the **Menu** button on the front panel or on the IR remote control. The **Menu** button, on the front panel, will momentarily flash blue when it is pressed.

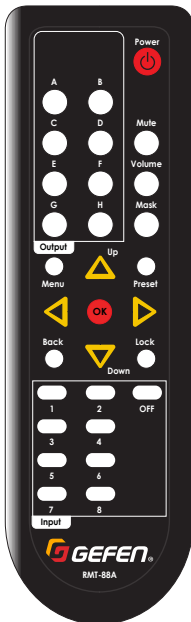
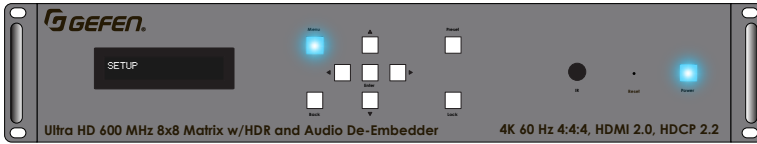

3. The **Setup** menu will be displayed:



4. Press and release the **▲** or **▼** buttons on the front panel or on the IR remote control, to select the **System** menu:



5. Press the **Enter** button on the front panel. If using the included IR remote control, press the **OK** button.
6. Press the **▲** or **▼** buttons on the front panel or on the IR remote control to select the **Factory Reset** menu.



7. Press the **Enter** button on the front panel or the **OK** button on the IR remote control. The matrix will prompt to confirm the factory-reset operation.



FACTORY RESET
>YES

8. Press and release the ▲ or ▼ buttons on the front panel or on the IR remote control, to select either **Yes** or **No**.



FACTORY RESET
>NO

9. Press the **Enter** button on the front panel or the **OK** button on the IR remote control to confirm the selection.

If Yes is selected, then the matrix will be reset to factory-default settings and will automatically be rebooted.

Rebooting the Matrix

Use this menu option to reboot the matrix.

1. Go to the *routing screen*. If the routing screen is not displayed, then press the **Back** button on the front panel or on the IR remote control until the *routing screen* is displayed.
2. Press and release the **Menu** button on the front panel or on the IR remote control. The **Menu** button, on the front panel, will momentarily flash blue when it is pressed.

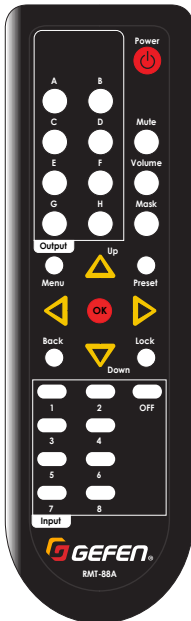
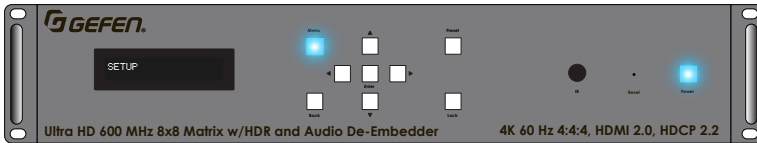

3. The **Setup** menu will be displayed:



4. Press and release the **▲** or **▼** buttons on the front panel or on the IR remote control, to select the **System** menu:



5. Press the **Enter** button on the front panel. If using the included IR remote control, press the **OK** button.
6. Press the **▲** or **▼** buttons on the front panel or on the IR remote control to select the **Reboot Unit** menu.



7. Press the **Enter** button on the front panel or the **OK** button on the IR remote control. The matrix will prompt to confirm the factory-reset operation.



REBOOT UNIT
>YES

8. Press and release the ▲ or ▼ buttons on the front panel or on the IR remote control, to select either **Yes** or **No**.



REBOOT UNIT
>NO

9. Press the **Enter** button on the front panel or the **OK** button on the IR remote control to confirm the selection.

If Yes is selected, then the matrix will automatically be rebooted.

Introduction to the Web Interface

The Ultra HD 600 MHz 8x8 Matrix w/HDR and Audio De-Embedder includes a built-in web interface. We recommend that the web interface be used to control the matrix as it provides easy management of all features used by the matrix.

▶ Logging In

1. Launch your favorite web browser.
2. In the address bar, type the IP address of the matrix.
3. The login page will be displayed.
4. Select the user from the **Username** drop-down list.

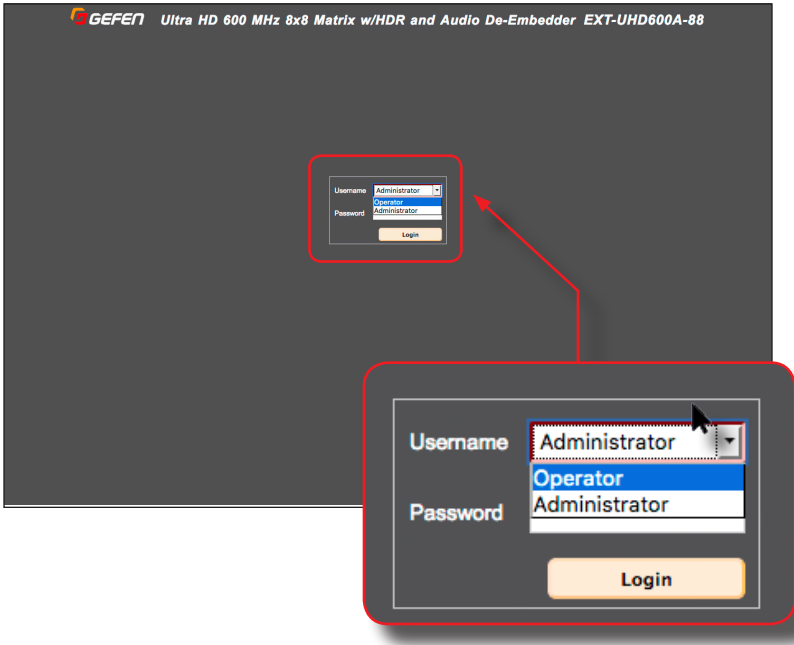

- **Operator**
The Operator username provides restricted access to the web interface. This username allows access to both the Routing and Status tabs, locking / unlocking and powering on / off the matrix.

The default password for the Operator user name is `Operator`. All passwords are case-sensitive. For information on changing the default password, see [Configuring Network Settings \(page 95\)](#).

- **Administrator**

The Administrator username provides full access to all features within the web interface.

The default password for the Administrator user name is `Admin`. All passwords are case-sensitive. For information on changing the default password, see [Configuring Network Settings \(page 95\)](#).

5. Enter the password for the selected username.
6. Click the **Login** button.
7. After a few moments, the **Routing** tab will be displayed.

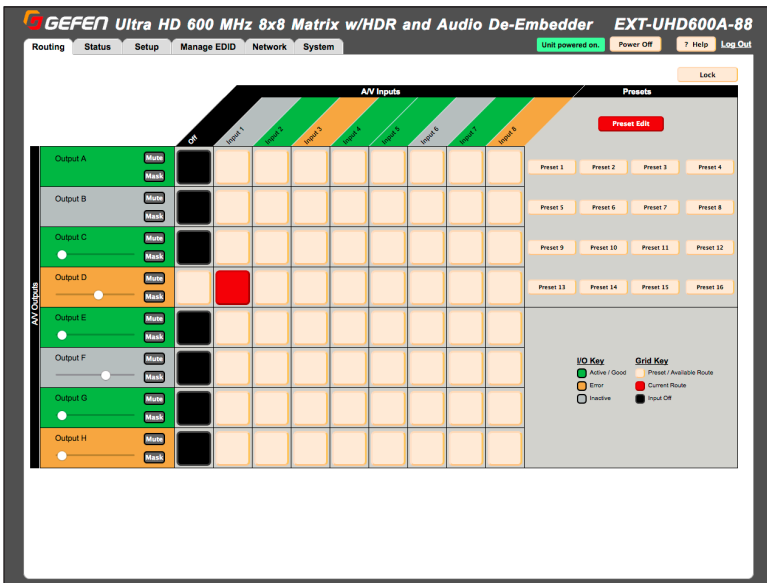

► **Administrator vs Operator**

As mentioned earlier, logging in as `Operator` provides restricted access to many of the available features within the web interface. This is summarized in the table below:

Administrator	Operator
<ul style="list-style-type: none"> • Access to all features 	<ul style="list-style-type: none"> • Access to Routing and Status tabs, only. • No access to the Preset Edit button under the Routing tab.

► Tabs and Sub-tabs

The web interface is organized into tabs, in the top-portion of the screen. Clicking on a tab will display a different screen.

The **Setup** and **Manage EDID** tab have their own set of tabs, which we will refer to as “sub-tabs”, as shown below.

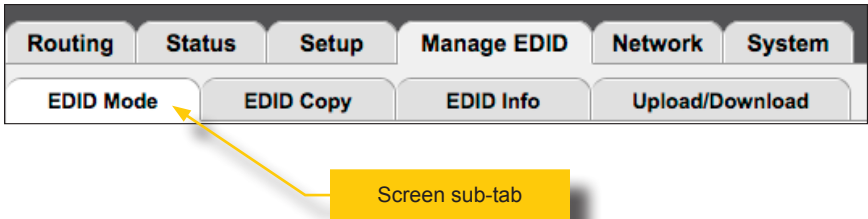
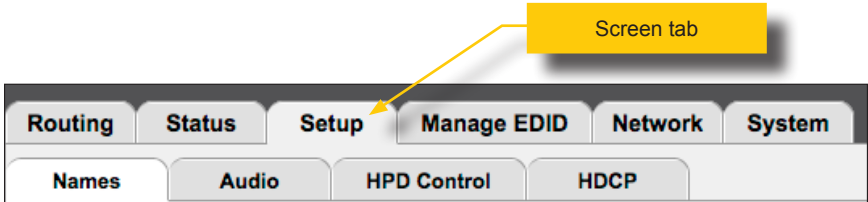

► Buttons

Several screen contain buttons which allow the selection of a particular mode or setting. Click the button for the desired setting. Buttons that are red represent a setting that is “turned on”. If the button is pale-yellow, then the feature is “turned off”:

- Feature is “turned on”



- Feature is “turned off”

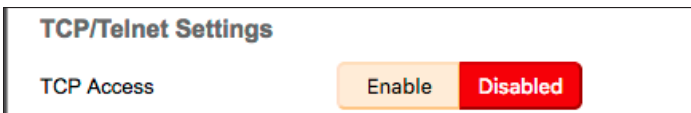

- If a button is “grayed-out”, then this means that the setting is not available. This usually requires that another setting must be *enabled* before setting a “sub-set” of that feature.

For example, note that both the **Login Message on Connect** buttons are disabled in the illustration, below:

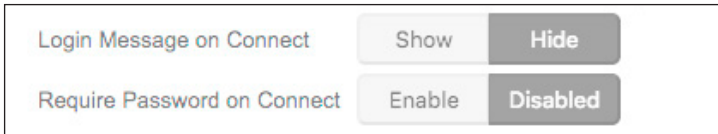

In order to change these particular settings, **TCP Access** must be enabled.

After clicking the **Enable** button, next to **TCP Access**, the **Login Message on Connect** buttons are now available.

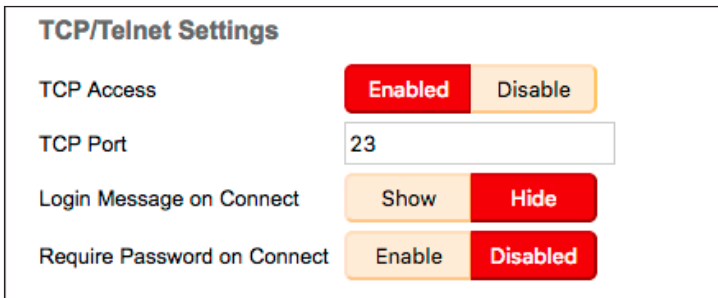

► Legend

The legend, near the bottom-right corner of the Routing screen, defines the colors used to indicate the status of an input or output:

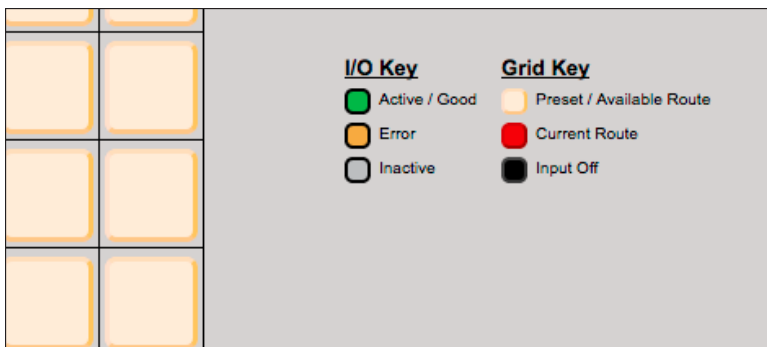

**Active / Good**

Columns or rows that are highlighted in green, indicate that an active source or sink is connected to the that input / output.

**Error**

Although a rare occurrence, this indicates an error (e.g. HDCP, etc.) with the source or sink device. These rows or columns are highlighted in amber.

**Inactive**

Columns or rows which are highlighted in gray, indicate the absence of a source or sink device on that input or output.

**Preset / Available Route**

Squares that are light tan, indicate that the input and output is available for routing.

**Switch Audio / Video**

A red square indicates where an input has been routed to an output.

**Off**

Black squares indicate that the input is set to the OFF state. The OFF input is an additional input that can be selected to simulate a source that is not present.

GEFEN Ultra HD 600 MHz 8x8 Matrix w/HDR and Audio De-Embedder EXT-UHD600A-88

Routing Status Setup Manage EDID Network System USB powered on Power Off 7 Help Log Out

AVC Outputs: Output A, Output B, Output C, Output D, Output E, Output F, Output G, Output H

AV Inputs: OFF, Input 1, Input 2, Input 3, Input 4, Input 5, Input 6, Input 7, Input 8

Presets: Present 1, Present 2, Present 3, Present 4, Present 5, Present 6, Present 7, Present 8, Present 9, Present 10, Present 11, Present 12, Present 13, Present 14, Present 15, Present 16

Legend:

- ID Key:**
 - Green: Active / Good
 - Amber: Error
 - Gray: Inactive
- Grid Key:**
 - Light Tan: Preset / Available Route
 - Red: Current Route
 - Black: Input Off

Locking the Matrix

Locking the matrix disables the front-panel controls, IR routing, and the built-in web interface. This is useful in preventing an accidental change to matrix settings by inadvertently pressing any of the front-panel buttons.



Information

Locking the Matrix Controller will also disable routing and other operations within the Web Interface.

1. Click the **Routing** tab.
2. Click the **Lock** button near the top of the screen.

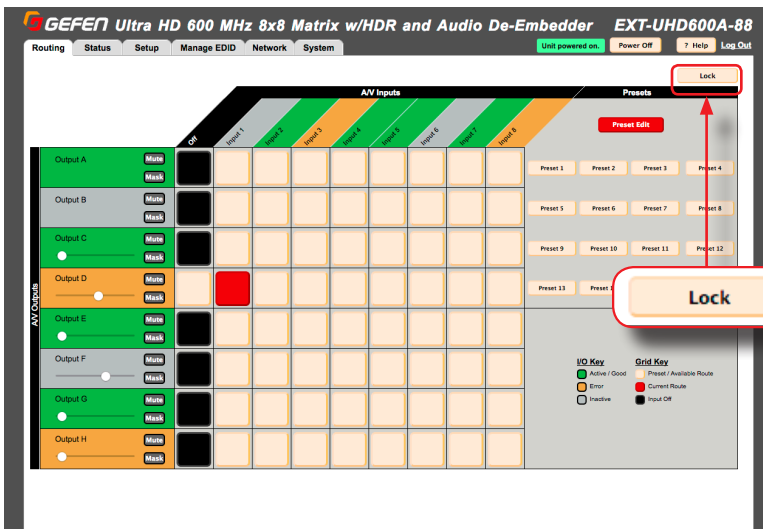

3. Once pressed, the **Lock** button will read “Unlock Matrix”. The Lock button on the front panel will also glow bright blue. The matrix is now locked.
4. Click the **Unlock Matrix** button to unlock the matrix.



5. The **Unlock** button will now read “Lock”. The **Lock** button on the front panel will also turn-off. The matrix is now unlocked.

Viewing the Routing Status

1. Click the **Routing** tab.

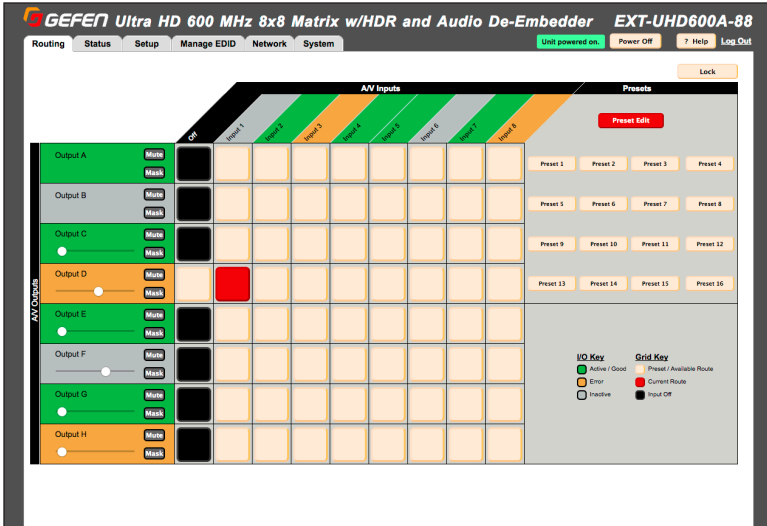

2. Locate the desired output from the rows on the left, then read across until a routing indicator (red square) is encountered.

Note the column where the red square is located. Each column identifies an input and each row represents an output. The output and inputs names can be changed, if desired. See [Changing Input and Output Names](#) (page 82) for more information.

For example, in the illustration below, **Input 2** is routed to **Output C**.

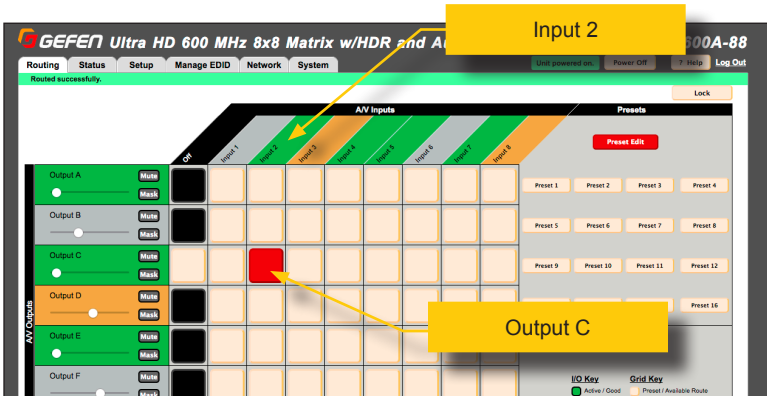

Routing Inputs and Masking Outputs

▶ Routing Inputs

1. Click the **Routing** tab.
2. Located the desired output, from the rows on the left side of the screen.
3. Click the desired input. Use the column, with the input names, as a guide when selecting the input.

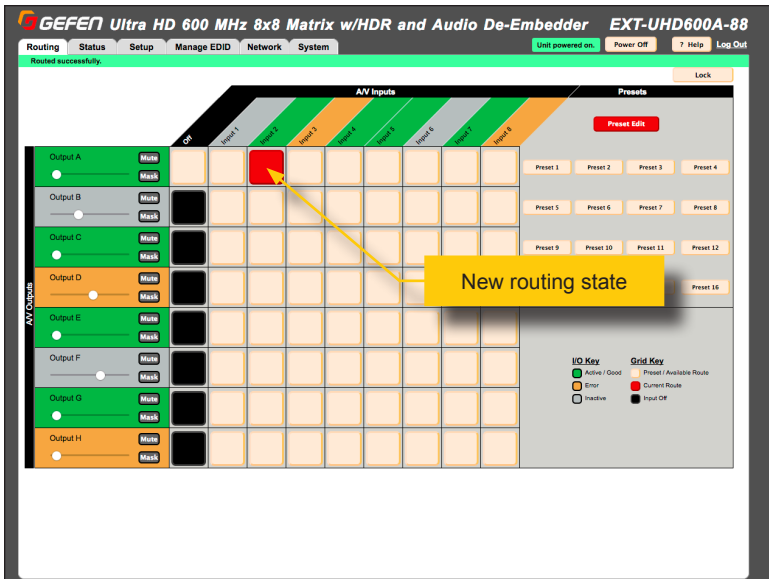

4. Click the square at the intersection of both the output and input.

A *routing indicator* (red square) will appear at the intersection of the row (output) and column (input) of the current routing state.

If the routing process is successful, then a green bar will appear at the top of the page with the text "Routed successfully"..

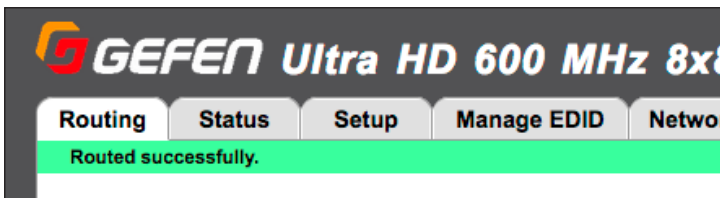

► **Placing an input in the OFF state**

1. Click the box in the first column, next to the desired output.
2. The box, in the column, will turn black, indicating that the input is “off”. The OFF is an additional input that can be selected to simulate a source that is not present.

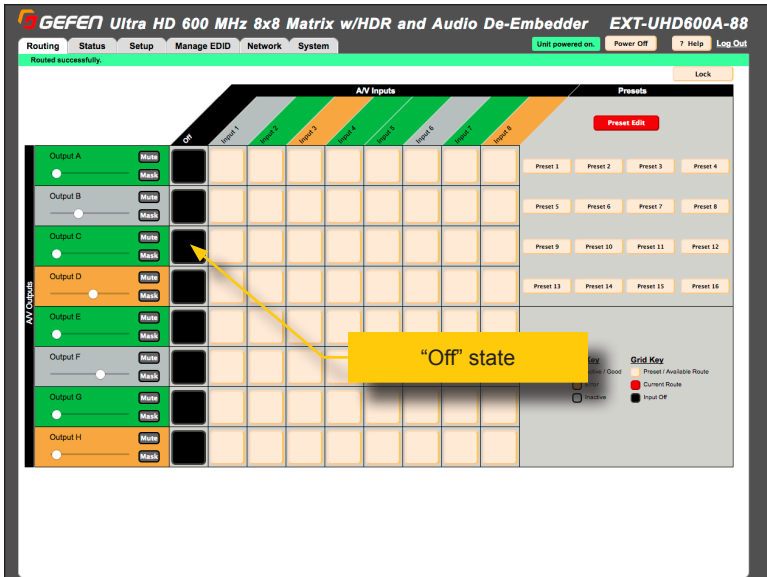

As with any routing operation, if the operation is successful, a green bar will appear at the top of the page with the text “Routed successfully”.

► Masking Outputs

1. Click the **Routing** tab.
2. Mask the desired output by clicking the **Mask** button. The **Mask** button will turn red, indicating that the selected output is masked.

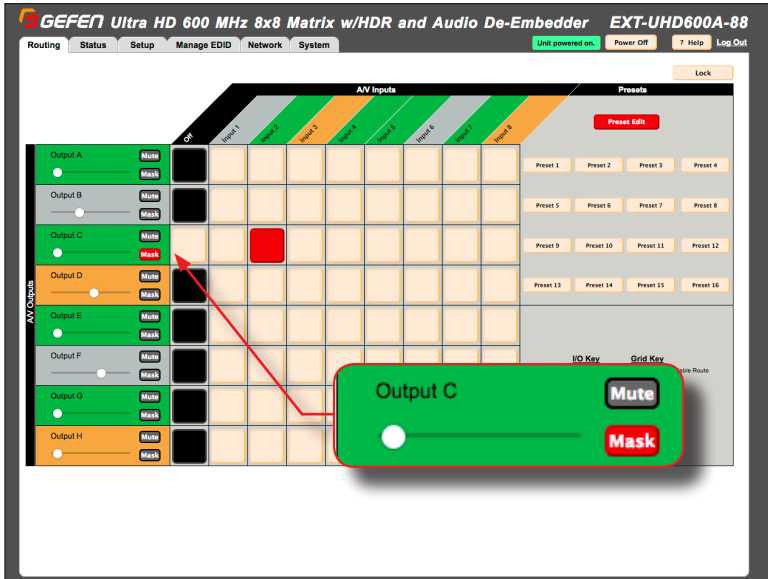

3. To unmask the output, click the **Mask** button again. The button will turn gray.

Routing Presets

► Creating / Editing a Preset

1. Click the **Routing** tab.
2. Under the **Presets** section, click the **Preset Edit** button.

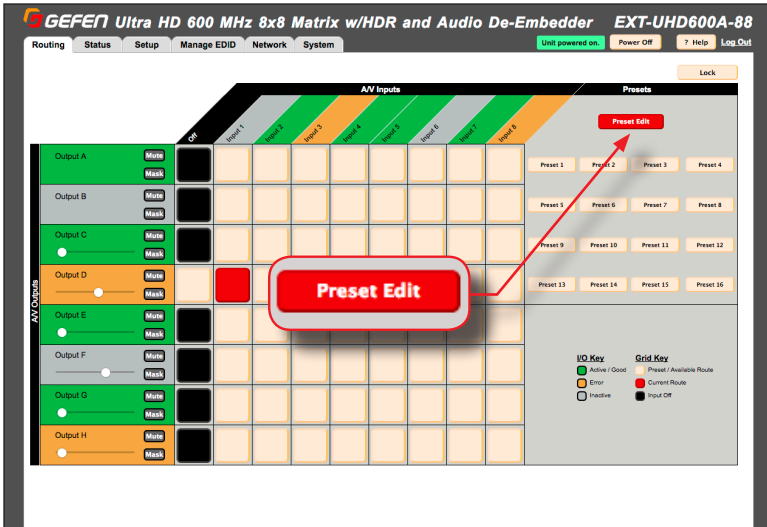

3. The preset buttons will begin to flash and the **Preset Edit** button will read **Choose One**.

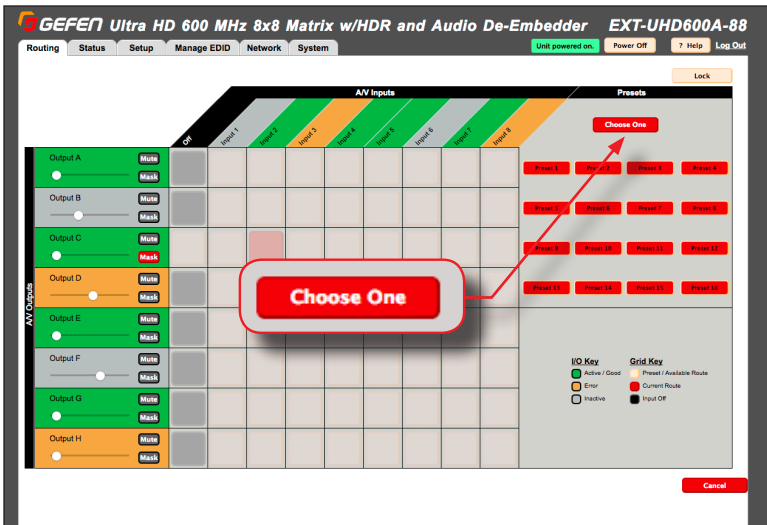

- Click the desired preset to edit.
- The selected preset will be highlighted. In this example, we will select **Preset 6**.

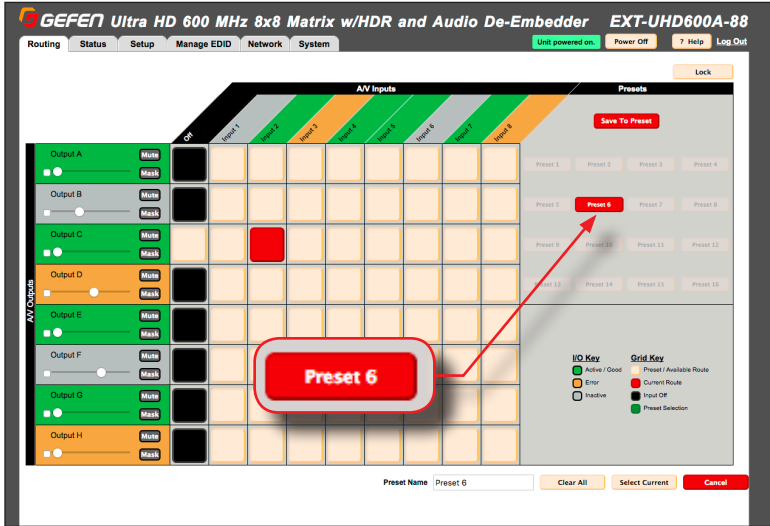

- Select the desired routing state for each input/output. See [Routing Inputs and Masking Outputs](#) (page 75), if necessary. The *preset selections* for the selected preset, will be indicated by a green square, as shown below. Note that an output can also be set to OFF.
- To save/set the audio volume level for an output, click the check box, next to the volume slider, then set the volume slider to the desired level.

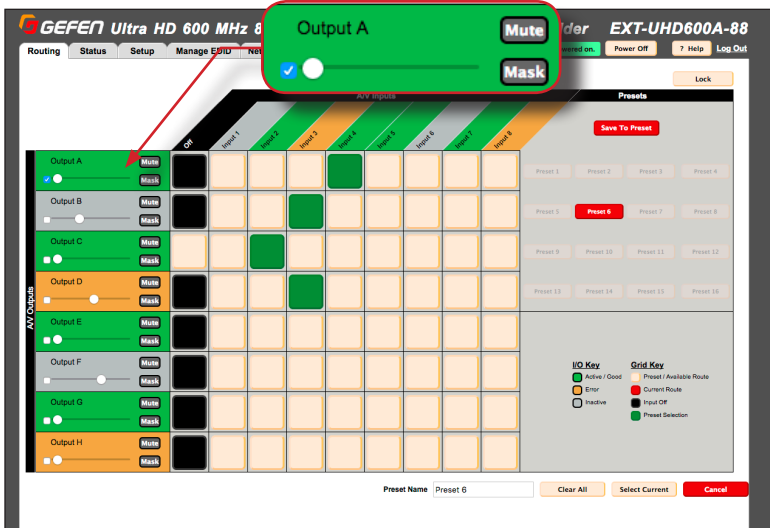

- After the desired routing states, for input/output have been assigned, provide a name for the preset in the **Preset Name** field.

The screenshot displays the GEFEN Ultra HD 600 MHz 8x8 Matrix w/HDR and Audio De-Embedder EKT-UHD600A-88 web interface. The interface is divided into several sections: a top navigation bar with tabs for Routing, Status, Setup, Manage EDID, Network, and System; a main routing matrix; and a bottom control area. The routing matrix shows AV Inputs (Input 1-8) and AV Outputs (Output A-H). A 'Save To Preset' button is highlighted in a red box at the top. Below the matrix, a 'Preset Name' field contains 'SamplePreset'. At the bottom, three buttons are highlighted in red boxes: 'Clear All', 'Select Current', and 'Cancel'.

- ▶ To clear the *preset selections* for the current preset, click the **Clear All** button.
- ▶ To use the current routing state as the preset selection, click the **Select Current** button.
- ▶ To abort the editing of the preset, click the **Cancel** button.

- Click the **Save to Preset** button to save the preset.
- Repeat steps 2 - 8, as desired, for each preset.

▶ Recalling a Preset

- Click the **Routing** tab.
- Click the desired preset button.

Input and Output Status

Provides video and audio information for all inputs and outputs.

1. Click the **Status** tab within the built-in web interface.
2. Information on each input is listed in the top portion of the screen.
3. Information on each output is listed in the bottom portion of the screen.

Input section

Name	Input 1	Input 2	Input 3	Input 4	Input 5	Input 6	Input 7	Input 8
Color Depth		8 bit		8 bit	10 bit			10 bit
Color Space		RGB 4:4:4		RGB 4:4:4	YCbCr 4:4:4			YCbCr 4:4:4
HDR		No		No	No			No
HDCP		1.4		1.4	2.2			2.2
3D		Frame Packing		Frame Packing	Frame Packing			Frame Packing
Active Signal	No	Yes	No	Yes	Yes	No	Yes	No
Vertical Resolution		3840		3840	3840			3840
Horizontal Resolution		2160		2160	2160			2160
Progressive / Interlaced		P		P	P			P
Refresh Rate		120Hz		120Hz	120Hz			120Hz
Video Mode		HDMI		HDMI	HDMI			HDMI

Output section

Name	Output A	Output B	Output C	Output D	Output E	Output F	Output G	Output H
RSENSE	High	Low	High	Low	High	Low	High	Low
HPD	High	Low	High	Low	High	Low	High	Low
HDCP		2.2		2.2	2.2			2.2
Video Mode		HDMI		HDMI	HDMI			HDMI

The table below outlines the information that is available for each section:

Input	Output
<ul style="list-style-type: none"> • Color depth • Color space • HDR • HDCP (version) • 3D (status) • Active Signal • Vertical resolution • Horizontal Resolution • Progressive / interlaced • Refresh rate • Video mode • Audio Format 	<ul style="list-style-type: none"> • Rsense • HDP • HDCP • Video mode

Changing Input and Output Names

By default, the names of each output are **Output A - Output D**. The names of each input are **Input 1 - Input 4**. Each of these names can be changed, as desired, to suit the type of device that is connected to the input or output.



Information

Both input and output names cannot exceed 12 characters in length.

1. Click the **Setup** tab within the built-in web interface.
2. Click the **Names** sub-tab.
3. Click in the field of the desired output or input to be changed.

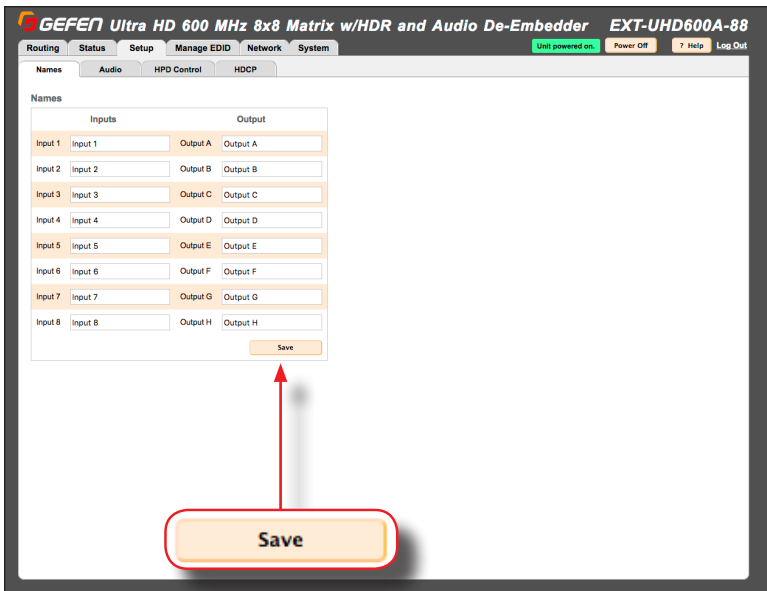

4. Once all changes have been made, click the **Save** button.
5. The new input / output name(s) will be displayed within the **Routing** tab. Note that the new input / output name(s), to the left of each field, will not be changed.

Audio

The **Audio** tab handles how audio is output from the matrix.

1. Click the **Setup** tab within the built-in web interface.
2. Click the **Audio** sub-tab.
3. Click either Fixed or Variable for each output.
 - **Fixed**
In this mode, the output volume is set to 100 and variable adjustment is disabled.
 - **Variable**
In this mode, volume is adjustable between 0 and 100.



HPD Control

HPD (Hot-Plug Detect) is an HDMI feature which senses if the HDMI cable is disconnected, from the source or sink device, and then re-initializes the HDMI link if necessary. Within the web interface, the HPD pulse can be sent to the selected input, and reset the HDMI connection without disconnecting any cables. The connected display will flash when an HPD signal is received.

1. Click the **Setup** tab within the built-in web interface.
2. Click the **HPD Control** sub-tab.
3. Click the **Pulse** button for the desired input. Click the **Pulse All Inputs** button to send an HPD signal to all inputs.

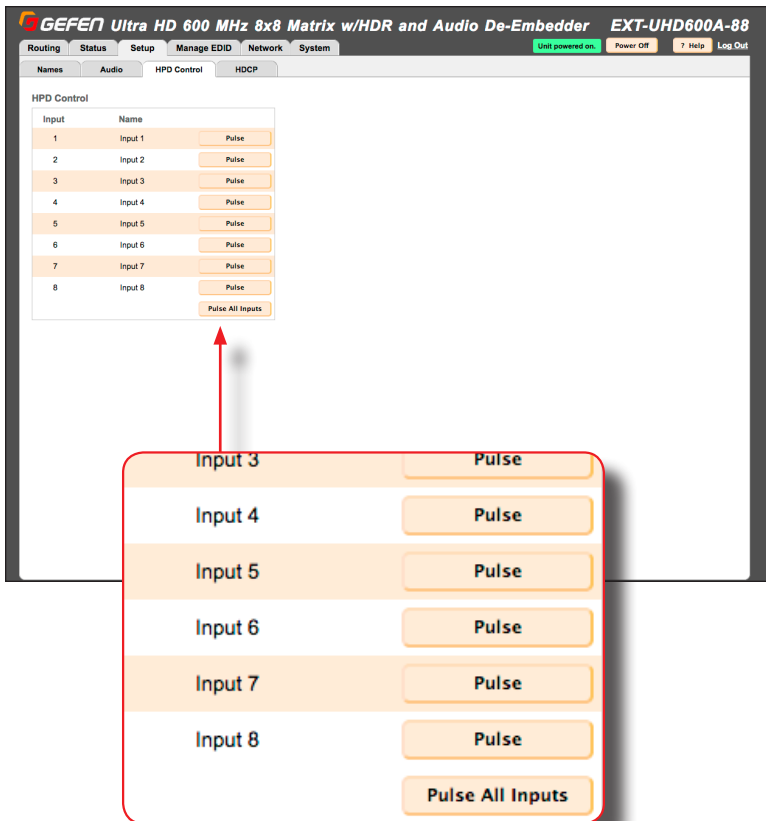

HDCP

This feature allows HDCP content to either be passed-through or rejected on each input. Outputs can either follow the input status or can be set to always encode HDCP. Note that using the “Reject” feature, on an input, does *not* decrypt HDCP content.

1. Click the **Setup** tab within the built-in web interface.
2. Click the **HDCP** sub-tab.
3. For inputs, select the desired button next to the input.
 - ▶ **Reject** - Does not allow HDCP content to be passed through. Click the **Reject All** button to set all inputs to **Reject**.
 - ▶ **2.2** - Click this button if the sink device supports HDCP 2.2. Click the **All 2.2** button to set all inputs to **2.2**.
 - ▶ **1.4** - Click this button if the sink device only supports HDCP 1.4. Click the **All 1.4** button to set all inputs to **1.4**.

The screenshot shows the web interface for the GEFEDA Ultra HD 600 MHz 8x8 Matrix w/HDR and Audio De-Embedder (EXT-UHD600A-88). The interface is in the 'Setup' tab, specifically the 'HDCP' sub-tab. It displays a table for 'HDCP Handshake' configuration.

Input	Name	Reject	2.2	1.4
1	Input 1	Reject	2.2	1.4
2	Input 2	Reject	2.2	1.4
3	Input 3	Reject	2.2	1.4
4	Input 4	Reject	2.2	1.4
5	Input 5	Reject	2.2	1.4
6	Input 6	Reject	2.2	1.4
7	Input 7	Reject	2.2	1.4
8	Input 8	Reject	2.2	1.4

Below the input table, there are buttons for 'Reject All' and 'All 2.2'. To the right, there is a table for 'Output' configuration:

Output	Name	Follow Input	Always Encode
1	Output A	Follow Input	Always Encode
2	Output B	Follow Input	Always Encode
3	Output C	Follow Input	Always Encode
4	Output D	Follow Input	Always Encode
5	Output E	Follow Input	Always Encode
6	Output F	Follow Input	Always Encode
7	Output G	Follow Input	Always Encode

A red callout box highlights the 'Reject' button for Input 1 in the input table.

4. For outputs, select the desired button next to the output.
 - ▶ **Follow Input** - Click this button to have the output follow the setting used on the input. Click the **Follow All** button to set all outputs to **Follow Input**.
 - ▶ **Always Encode** - Encodes the output signal with HDCP 2.2, regardless of the input signal.

Click the **All Encode** button to set all outputs to **Always Encode**.

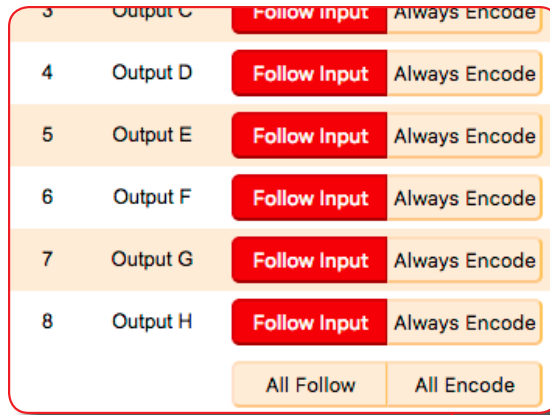

GEFEN Ultra HD 600 MHz 8x8 Matrix w/HDR and Audio De-Embedder EXT-UHD600A-88

Unit powered on | Lower Off | 7 Help | Log Out

Routing | Status | Setup | Manage EDID | Network | System

Names | Audio | HPD Control | HDCP

HDCP Handshake

Input	Name	Reject	2.2	1.4
1	Input 1	Reject	2.2	1.4
2	Input 2	Reject	2.2	1.4
3	Input 3	Reject	2.2	1.4
4	Input 4	Reject	2.2	1.4
5	Input 5	Reject	2.2	1.4
6	Input 6	Reject	2.2	1.4
7	Input 7	Reject	2.2	1.4
8	Input 8	Reject	2.2	1.4
Reject All		All 2.2	All 1.4	

Output	Name	Follow Input	Always Encode
1	Output A	Follow Input	Always Encode
2	Output B	Follow Input	Always Encode
3	Output C	Follow Input	Always Encode
4	Output D	Follow Input	Always Encode
5	Output E	Follow Input	Always Encode
6	Output F	Follow Input	Always Encode
7	Output G	Follow Input	Always Encode
8	Output H	Follow Input	Always Encode
		All Follow	All Encode

Setting the EDID Mode

The **EDID Mode** tab allows the desired EDID mode (internal preset, external, or custom) to be set for each input.

1. Click the **Manage EDID** tab within the built-in web interface.
2. Click the **EDID Mode** sub-tab.
3. Select the desired EDID mode for each input using the drop-down list.

The screenshot shows the 'Manage EDID' section of the web interface. The 'EDID Mode' sub-tab is active. A table lists 8 inputs. For each input, there is a dropdown menu for 'EDID Mode', a text field for 'EDID Name', and a button for 'EDID Lock'. A red box highlights the dropdown menu for Input 2, which is open, showing a list of options: -- Internal --, UHD 4k 600 MHz 2ch, UHD 4k 600 MHz Multi-Ch, UHD 4k 300 MHz 2ch, UHD 4k 300 MHz Multi-Ch, 1080p 2ch, 1080p Multi-Ch, -- External --, External EDID (highlighted in blue), -- Custom --, User-defined, and 1080p Multi-Ch. A red arrow points from the dropdown menu to the 'External EDID' option. Another red box highlights the 'External EDID' option in the dropdown menu.

Input	Input Name	EDID Mode	EDID Name	EDID Lock
1	Input 1	User-defined	Sony	Lock Unlocked
2	Input 2	External EDID	Panasonic	Lock Unlocked
3	Input 3	1080p Multi-Ch	Vizio	Lock Unlocked
4	Input 4	1080p 2ch	BenQ	Lock Unlocked
5	Input 5	1080p Multi-Ch	Sony	Lock Unlocked
6	Input 6	1080p Multi-Ch	Panasonic	Lock Unlocked
7	Input 7	1080p Multi-Ch	Vizio	Lock Unlocked
8	Input 8	1080p Multi-Ch		

If the **EDID Mode** is set to **External**, then the name of the downstream EDID (device) will appear under the EDID Name column, as shown. The **External** modifies the EDID, parsing all outputs to determine optimum compatibility among features for all connected displays.

The close-up shows the 'EDID Name' and 'EDID Lock' columns. The 'EDID Name' column contains the text 'Sony'. The 'EDID Lock' column contains two buttons: 'Lock' and 'Unlocked'. A red circle highlights the 'Lock' button.

► Using a Custom EDID

The **Custom - User-defined** setting is used to store a custom EDID in the selected input. To use a custom EDID, follow the instructions below:

1. Select **Custom - User-defined** from the drop-down list of the desired input.

EDID Mode	EDID Name
User-defined	Sony

2. Copy or upload an EDID to the input that is using the **Custom** mode. See one of the following sections for more information on copying or uploading EDID data:

- [Copying EDID Data \(page 89\)](#).
- [Uploading and Downloading EDID Data \(page 92\)](#).

3. Set the EDID Lock mode to either **Locked** or **Unlocked**:

- **Locked**
Prevents the EDID from being changed on the input..
- **Unlocked**
Allows the EDID to be changed.

Mode	EDID Name	EDID Lock
<input type="text" value="User-defined"/>	Sony	<input type="button" value="Locked"/> <input type="button" value="Unlock"/>
<input type="text" value="User-defined"/>	Panasonic	<input type="button" value="Lock"/> <input type="button" value="Unlocked"/>

4. The name of the custom EDID will appear under the **EDID Name** column.

Copying EDID Data

The **EDID Copy** tab allows an EDID to be copied from an input or output (sink device) to any input. In order to copy an EDID to an input, the input must be set to **Custom - User-defined** mode and then unlocked. See [Setting the EDID Mode \(page 87\)](#) for more information.

1. Click the **Manage EDID** tab within the built-in web interface.
2. Click the **EDID Copy** sub-tab.
3. Click the button of the desired output or input from the **Select EDID to Copy** section. Select only one input or output at a time.

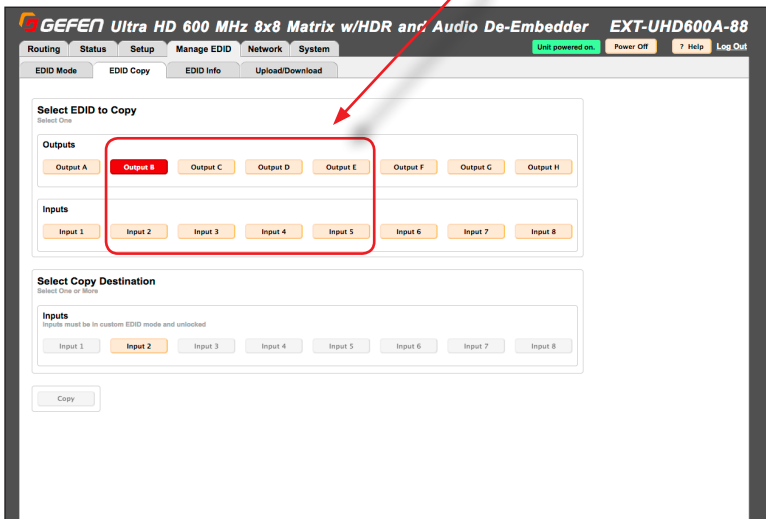
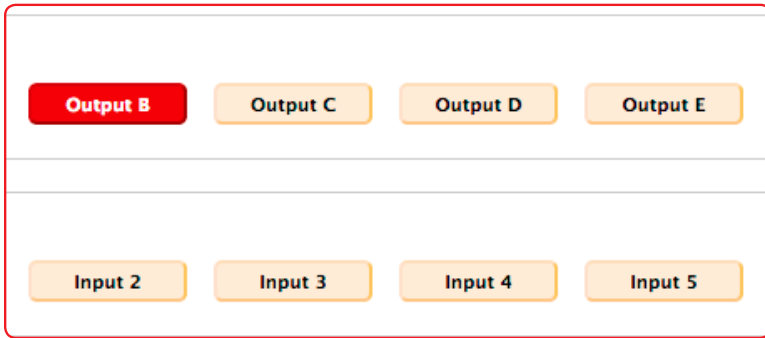

- After the input or output is selected, click the button for the corresponding input where the EDID will be copied. One or more inputs can be selected at a time.

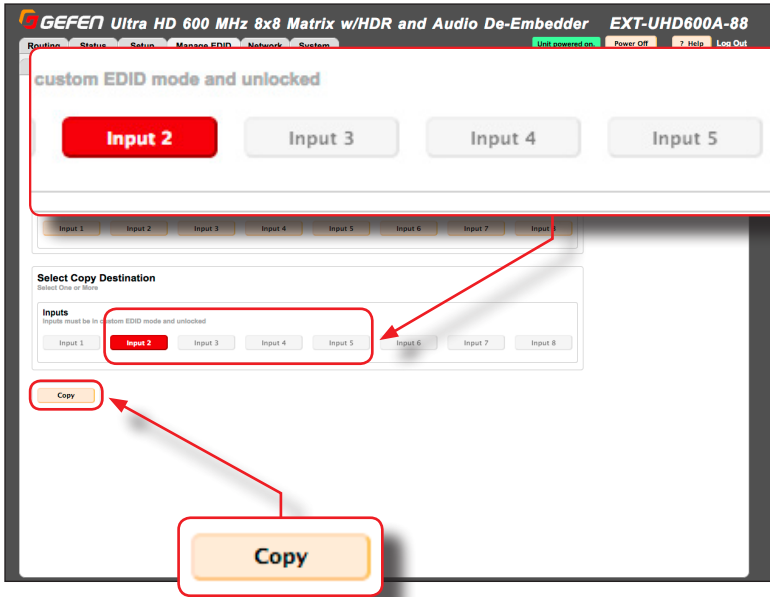

- Click the **Copy** button. The **Copy** can only be pressed when both an output or input (the source) and an input (destination) are selected.
- The EDID copy process is complete. Repeat steps 3 - 5 as desired.



Information

If an Input destination is disabled ("grayed-out"), then this means that the EDID has not been set to "User-Defined". See [Setting the EDID Mode \(page 40\)](#) for information on setting the EDID mode.

Getting EDID Information

The **EDID Info** tab allows the EDID information, from an input or sink device, to be displayed.

1. Click the **Manage EDID** tab within the built-in web interface.
2. Click the **EDID Info** sub-tab.
3. Select the desired input or output from the **Choose EDID** drop-down list.

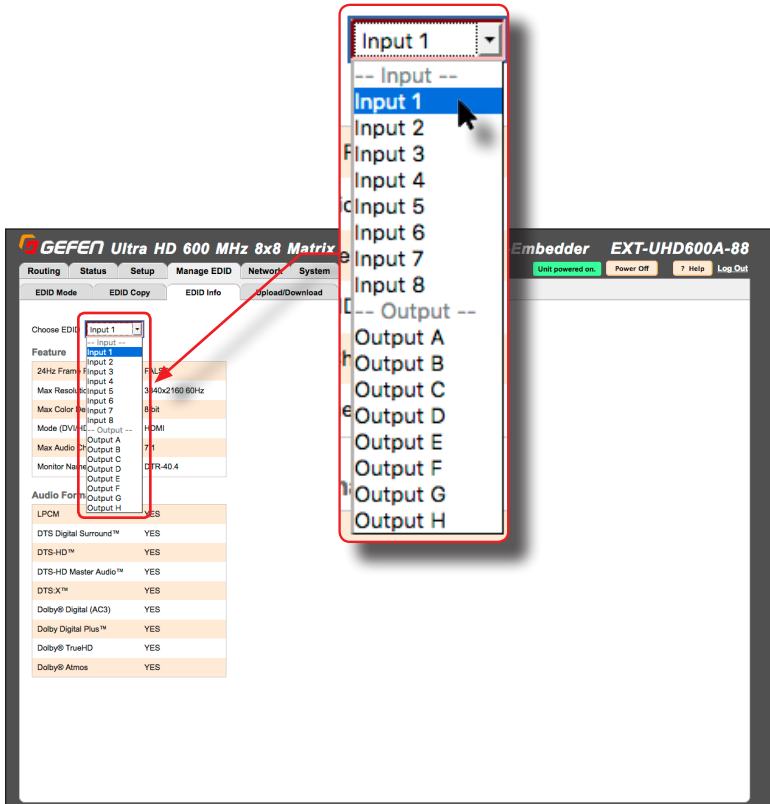

Uploading and Downloading EDID Data

The **Upload / Download** tab allows EDID data from an input, output, or one of the internal EDID presets, to be downloaded and saved as a file on your computer. An EDID file can also be uploaded to any (unlocked) input.

▶ Downloading an EDID

1. Click the **Manage EDID** tab within the built-in web interface.
2. Click the **Upload/Download** sub-tab.
3. Select the desired input, output, or internal EDID preset to be downloaded using the **Select EDID File** drop-down list.
4. Click the **Download** button.

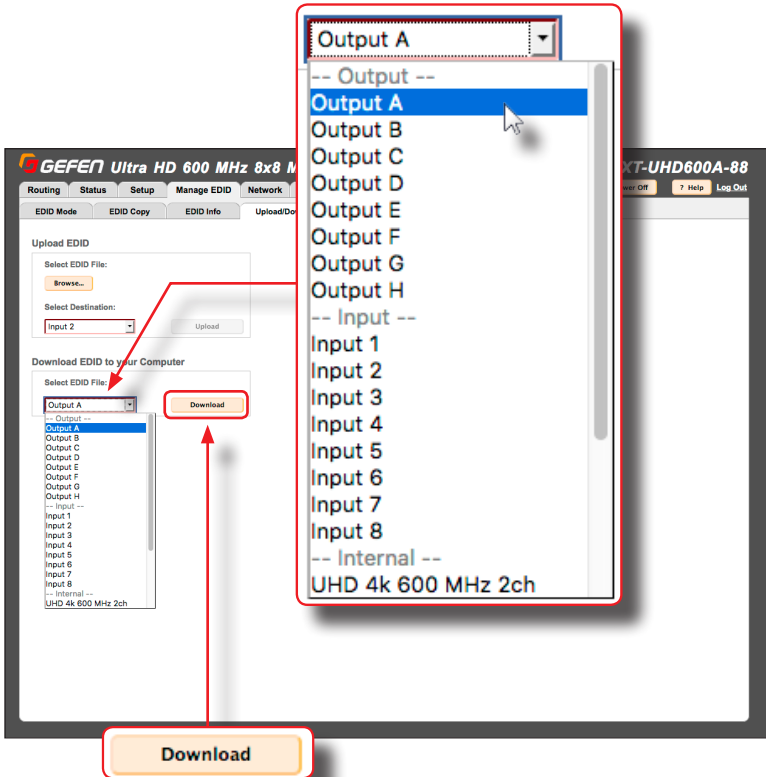

- The following dialog will be displayed:

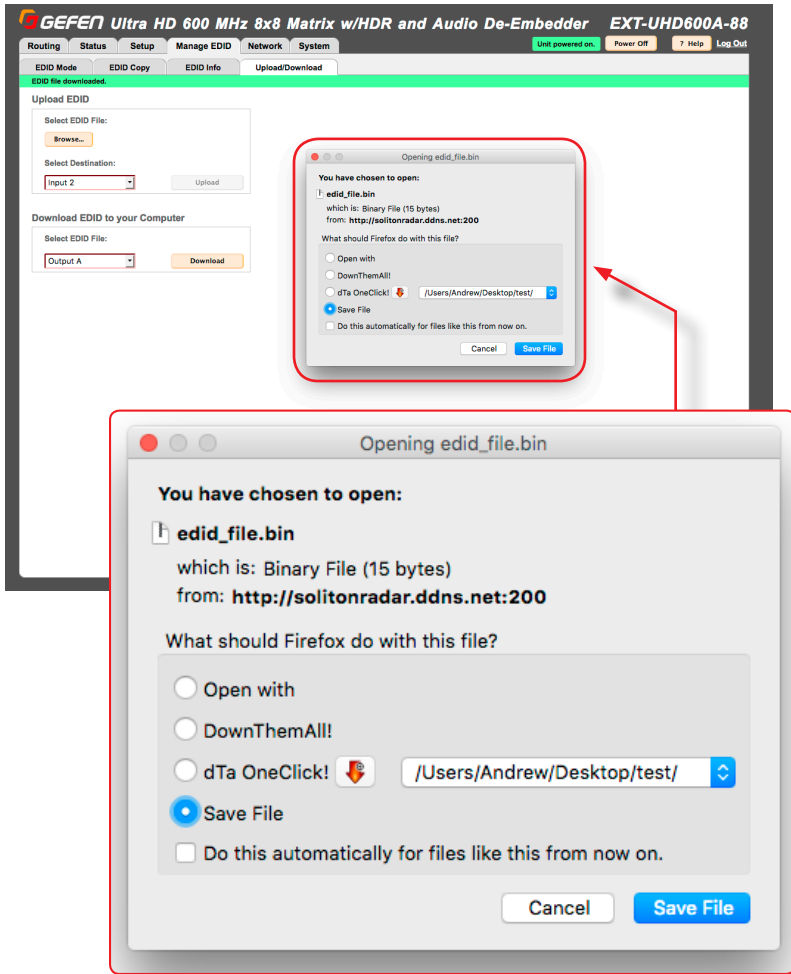

- Click the **Save File** button to save the EDID file to your computer.

- Mac OS X
The file will automatically be saved under
Macintosh HD\Users\[username]\Downloads.
- Windows OS
The file will be saved under
C:\Users\[username]\Downloads.

► Uploading an EDID

1. Click the **Manage EDID** tab within the built-in web interface.
2. Click the **Upload/Download** tab.
3. Set the input, where the EDID file will be uploaded, to **Custom** mode. See [Setting the EDID Mode \(page 87\)](#) for more information.
4. Click the **Browse...** button under **Upload EDID** section.
5. The **File Upload** dialog will be displayed.
6. Select the EDID file from your computer. The EDID file must be in `.bin` format. After the file is selected, click the **OK** button on the dialog box.
7. Select the input where the EDID will be uploaded using the **Select Destination** drop-down list. In order for an input to be selected, it must be unlocked and set to **Custom**. Refer to [Setting the EDID Mode \(page 87\)](#) for more information.
8. Click the **Upload** button.

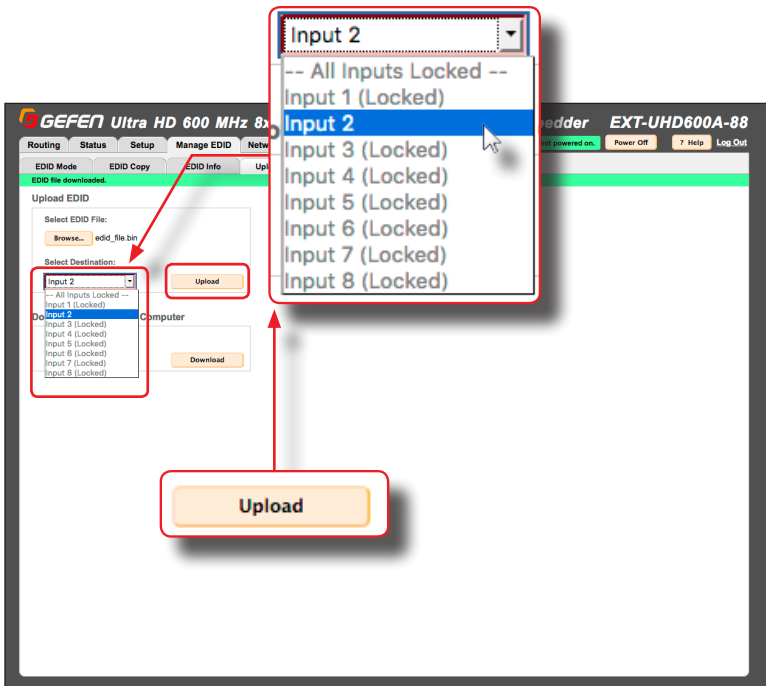

Configuring Network Settings

Once the matrix is configured on the network using Gefen Syner-G, the network settings can be changed within the built-in web interface. To access the network settings, click the **Network** tab in the built-in web interface.

When changing any network setting, click the **Save** button at the bottom of the page. To revert network settings to factory default, click the **Set Network Defaults** button.

► IP Settings

1. Set the network mode by clicking the **Static** or **DHCP** button.
2. If set to **Static** mode, then enter the IP address, subnet mask, and gateway address in the **IP Address**, **Subnet**, and **Gateway** fields, respectively. If set to **DHCP** mode, the DHCP server will assign these values.
3. Enter the HTTP listening port in the **HTTP Port** field.

The screenshot displays the 'Network' configuration page for a Gefen Ultra HD 600 MHz 8x8 Matrix w/HDR and Audio De-Embedder (EXT-UHD600A-88). The 'IP Settings' section is highlighted with a red box, showing the following values:

IP Address	192.168.1.72
Subnet	255.255.255.0
Gateway	192.168.1.254

Below this, the 'IP Settings' form is shown with a red box highlighting the MAC Address (00:1C:91:02:20:03), HTTP Port (80), and Mode (Static) fields. The 'Mode' field has two buttons: 'Static' (selected) and 'DHCP'.

The 'TCP/Telnet Settings' section shows 'TCP Access' as 'Enabled', 'TCP Port' as '23', and 'Require Password on Connect' as 'Enabled'. The 'UDP Settings' section shows 'UDP Access' as 'Enabled', 'UDP Port' as '50007', and 'Remote UDP Access' as 'Enabled'. The 'Remote UDP IP Address' is '192.168.1.129' and the 'Remote UDP Port' is '50008'.

At the bottom of the page, there are buttons for 'Set Network Defaults' and 'Save'.

► TCP / Telnet Settings

For details on configuring TCP, see [Using Telnet, UDP, and RS-232](#) (page 112).

- **TCP Access:** Click the **Enable** button to allow Telnet access to the matrix. Otherwise, click the **Disable** button.
- **TCP Port:** Enter the TCP listening port in this field.
- **Login Message on Connect:** Click the **Show** button to display the welcome message at the beginning of a Telnet session. Otherwise, click the **Hide** button.
- **Require Password on Connect:** Click the **Enable** button to require password credentials at the beginning of a Telnet session.

The screenshot shows the GEFEN Ultra HD web interface with the following settings:

- TCP/Telnet Settings:**
 - TCP Access: **Enabled** (red button) / Disable (yellow button)
 - TCP Port: 23
 - Login Message on Connect: Show (yellow button) / **Hide** (red button)
 - Require Password on Connect: Enable (yellow button) / **Disabled** (red button)
- UDP Settings:**
 - UDP Access: Enable (yellow button) / **Disabled** (red button)
 - UDP Port: 50007
 - Remote UDP Access: Enable (yellow button) / **Disabled** (red button)
 - Remote UDP IP Address: 192.168.1.129
 - Remote UDP Port: 50008
- Web Login Settings:**
 - Username: Operator (yellow button) / **Administrator** (red button)
 - Old Password: []
 - New Password: []
 - Confirm New Password: []
- Discovery Protocol Settings:**
 - Enable Discovery: Enable (yellow button) / **Disabled** (red button)
 - Discover Read Only: Read Only (yellow button) / **Read/Write** (red button)
 - Find Your Device: Show Me (yellow button)
 - Product Description: 4x1 HDMI 2.0 True4K Ultra

Buttons at the bottom: Set Network Defaults (yellow), Save (yellow).

- **User Name:** This field is static and cannot be changed. Telnet sessions are restricted to **Admin** users.
- **Old Password:** Enter the old (current) password in this field. The factory-default password is `admin`.
- **New Password:** Enter the new password in this field.
- **Confirm New Password:** Confirm the new password by entering the new password in this field.



Information

Note that all passwords are case-sensitive.

The screenshot shows the web interface for a GEFEN Ultra HD 600 M7 device. The 'TCP/Telnet Settings' section is highlighted with a red box. The fields within this section are:

- User Name:** Admin
- Old Password:** (empty text input)
- New Password:** (empty text input)
- Confirm New Password:** (empty text input)

Other visible settings include:

- IP Settings:** IP Address (192.168.1.72), Subnet (255.255.255.0), Gateway (192.168.1.254), Mode (Static/DHCP).
- UDP Settings:** UDP Access (Enable/Disabled), Remote UDP Access (Enable/Disabled), Remote UDP IP Address (192.168.1.129), Remote UDP Port (50008).
- Web Login Settings:** Username (Operator/Administrator), Old Password, Confirm New Password.
- Discovery Protocol Settings:** Enable Discovery (Enable/Disabled), Discover Read Only (Read Only/Read/Write), Product Description (4x1 HDMI 2.0 True4K Ultra).

Buttons at the bottom include 'Set Network Defaults' and 'Save'.

► UDP Settings

For details on configuring UDP, see [Using Telnet, UDP, and RS-232](#) (page 112).

- **UDP Access:** Click the **Enable** button to use the UDP protocol with the matrix. Otherwise, click the **Disable** button.
- **UDP Port:** Enter the TCP listening port in this field.
- **Remote UDP Access:** Click the **Enable** button to set the remote UDP address and UDP listening port. This feature only needs to be *enabled* if feedback to the matrix is required. Otherwise, this feature can be *disabled*.

The screenshot shows the web interface for configuring a device (HD600A-88). The 'UDP Settings' section is highlighted with a red box. Within this section, two sub-sections are further highlighted:

- UDP Access:** This sub-section contains a 'UDP Access' toggle with 'Enable' (selected) and 'Disable' buttons, and a 'UDP Port' field containing the value '50007'.
- Remote UDP Access:** This sub-section contains a 'Remote UDP Access' toggle with 'Enable' (selected) and 'Disable' buttons, and three fields: 'Remote UDP IP Address' (192.168.1.129), 'Remote UDP Port' (50008), and 'Remote UDP IP Address' (192.168.1.129).

Other visible settings include:

- IP Settings:** IP Address (192.168.1.72), Subnet (255.255.255.0), Gateway (192.168.1.254).
- TCP/Telnet Settings:** TCP Access (Enabled), TCP Port (23), Login Message on Connect (Show/Hide), Require Password on Connect (Enable/Disabled).
- Web Login Settings:** Username (Operator/Administrator), New Password, Old Password, Confirm New Password.
- Discovery Protocol Settings:** Enable Discovery (Enable/Disabled), Discover Read Only (Read Only/Read/Write), Find Your Device (Show Me), Product Description (4x1 HDMI 2.0 True4K Ultra).

- **Remote UDP IP Address:** Enter the remote UDP IP address in this field.
- **Remote UDP Port:** Enter the remote UDP listening port in this field.

► Web Login Settings

- **Username:** To change the password for the Administrator, click the **Administrator**. Otherwise, click the **Operator** button.
- **New Password:** Enter password for the selected username (above), in this field. Passwords are case-sensitive.
- **Old Password:** Enter the old (current) password in this field. Passwords are case-sensitive.
- **Confirm New Password:** To confirm the new password, re-enter the new password in this field. Passwords are case-sensitive.

The default password for the **Administrator** username is `admin`.

The default password for the **Operator** username is `operator`.

The screenshot shows the 'Web Login Settings' section of a device's web interface. The 'Administrator' button is highlighted in red. Below it, the 'Old Password' and 'Confirm New Password' fields are also highlighted in red. Red arrows indicate the flow from the 'Administrator' button to the 'Old Password' field, and then to the 'Confirm New Password' field.

Operator **Administrator** Old Password
Confirm New Password

Web Login Settings

Username: **Operator** **Administrator**

New Password:

Old Password:

Confirm New Password:

Discovery Protocol Settings

Enable Discovery: **Enable** **Disabled**

Discover Read Only: **Read Only** **Read/Write**

Find Your Device: **Show Me**

Product Description: 4x1 iHDIM 2.0 True4K Ultra

► Discovery Protocol Settings

- Enable Discovery:** Click the **Enable** button to enable “discovery” mode. Otherwise, click the **Disabled** button. In order for Gefen Syner-G to discover the matrix on a network, this feature must be *enabled*.
- Find Your Device:** Click the **Show Me** button to physically locate the matrix on a network. In order for the **Show Me** button to be available, the **Enable Discovery** button must be set to **Enable**. When the **Show Me** button is clicked, the button text will change to **Hide Me** and the buttons, on the front panel, will flash on the front panel of the matrix:



- Discovery Read Only:** When set to **Read Only**, the IP settings for the matrix will be displayed by Syner-G but they cannot be changed. In order to display and change IP settings from within Gefen Syner-G, click the **Read / Write** button.
- Product Description:** EXT-UHD600A-88 is the default product description. This name will be used to identify the matrix when using the Gefen Syner-G software.

The screenshot displays the web interface for the Gefen Syner-G device. The main content area is titled "Discovery Protocol Settings" and contains the following elements:

- Enable Discovery:** A toggle switch currently set to "Disabled".
- Find Your Device:** A button labeled "Show Me".
- Discover Read Only:** A toggle switch currently set to "Read Only".
- Product Description:** A text field containing "4x1 HDMI 2.0 True4K Ultra".

Red annotations highlight these specific controls. A separate inset image shows the physical front panel of the device, labeled "EXT-UHD600A-88", with buttons for "Power Off", "Help", and "Log Out".

System Settings

The **System** tab provides controls for various other matrix features. Each of these controls is described below.

▶ Main RS-232 Feedback

- Click the **Off** button to disable RS-232 feedback.
- Click the **On** button to enable RS-232 feedback.

▶ LED Brightness

Increases / decreases the brightness of the front-panel display.

- Move the slider to the right to increase the brightness.
- Move the slider to the left to decrease the brightness.

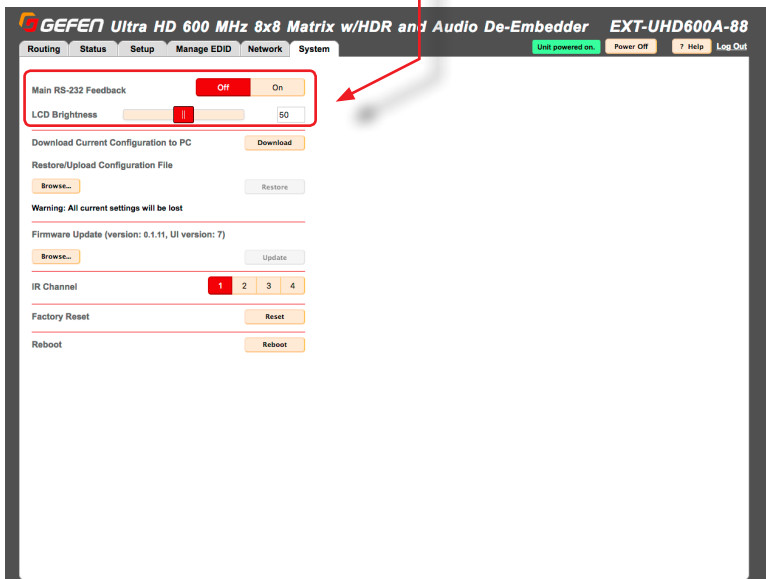

► **Download Current Configuration to PC**

Saves the current matrix configuration to a file on your computer.

1. Click the **Download** button.

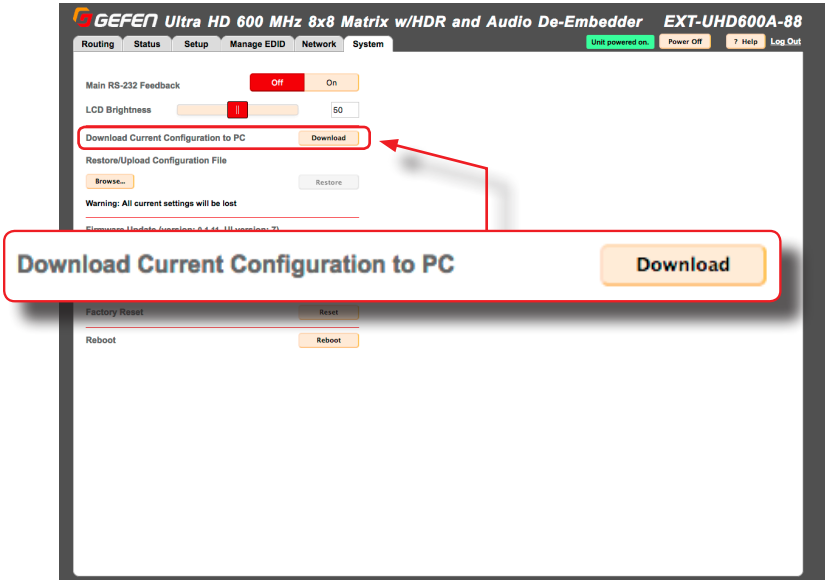

2. The following dialog box will be displayed:

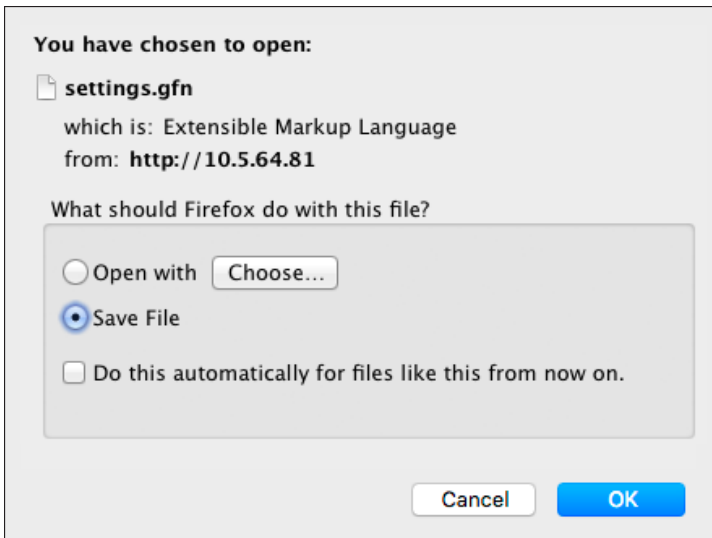

3. Click the **Save File** button to save the configuration file to your computer.

- Mac OS X
The file will automatically be saved under
Macintosh HD\Users\[username]\Downloads
- Windows OS
The file will be saved under
C:\Users\[username]\Downloads

► Restore / Upload Configuration File

Uploads the selected matrix configuration, from a file on your computer, to the matrix.

1. Click the **Browse...** button.

The screenshot shows the web interface for the GEFEN Ultra HD 600 MHz 8x8 Matrix w/HDR and Audio De-Embedder EXT-UHD600A-88. The 'System' tab is selected. In the 'Restore/Upload Configuration File' section, the 'Browse...' button is highlighted with a red box, and the filename 'settings.gfn' is displayed next to it. A red arrow points from the 'Restore' button in this section to a larger, detailed view of the 'Restore/Upload Configuration File' dialog box below. The dialog box shows the 'Browse...' button, the filename 'settings.gfn', and the 'Restore' button.

2. Select the desired configuration file from your computer. After the file has been selected, the filename will appear next to the **Browse...** button.

3. Click the **Restore** button to upload the file.

► Firmware Update

Uploads and applies the latest firmware file to the matrix.

1. Download the latest firmware from the Gefen web site.
2. Click the **Browse...** button.

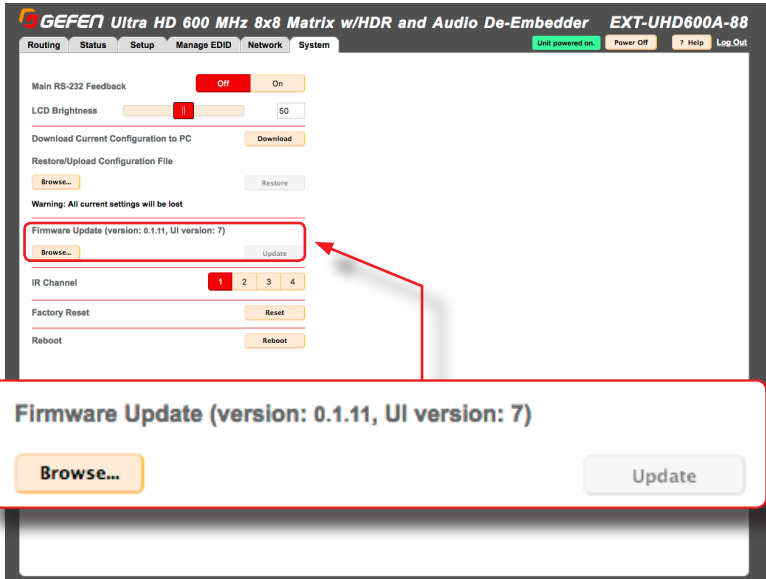

3. Select the firmware file on your computer.

The firmware must be a .bin file and will have the following naming convention: EXT-UHD600A-88 ([version]) (PACK) .bin.

4. Click the **Update** button.
5. The following message box will be displayed:

WARNING: Updating the firmware may overwrite some of your settings. Consider saving the configuration before updating the firmware. Are you sure you want to continue?

To save the configuration, before continuing, click the **Cancel** button on the message box. Refer to the section **Download Current Configuration to PC**.

6. Click the **OK** button on the message box.

7. After a few moments, the following message box will be displayed within the web interface:



8. After the update process completes, the matrix will automatically reboot.

► Setting the IR Channel

Sets the IR channel for the matrix. The matrix must be set to the same IR channel as the included IR remote control, in order for the IR remote control to communicate with the matrix.

1. Click the desired IR channel for the matrix by clicking one of the **IR Channel** buttons (1 - 4).

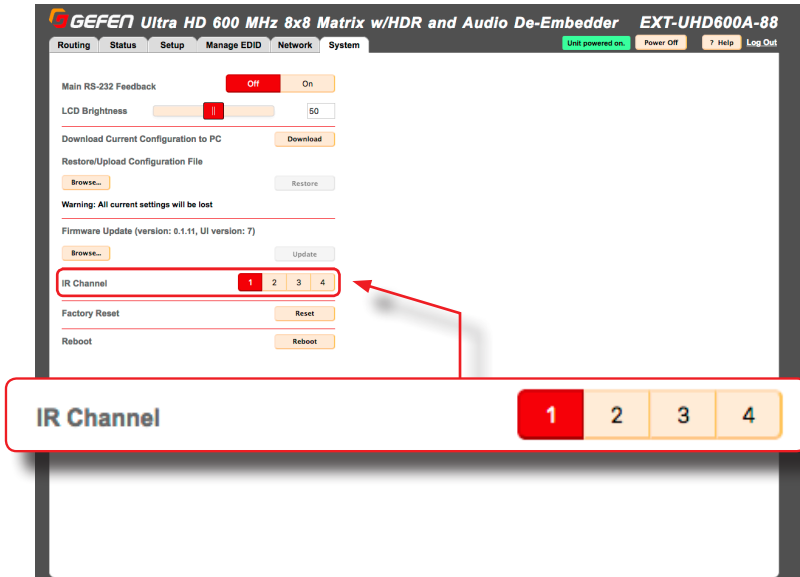

The IR channel setting is automatically saved. Rebooting the matrix is not required.

► Performing a Factory Reset

This feature restores the matrix to original factory-default settings.



Important

Performing this function will erase all current setting in your matrix. IP settings will be retained. To save the configuration, before continuing, refer to the section **Download Current Configuration to PC**.

1. Click the **Reset** button.



2. The following message box will be displayed:

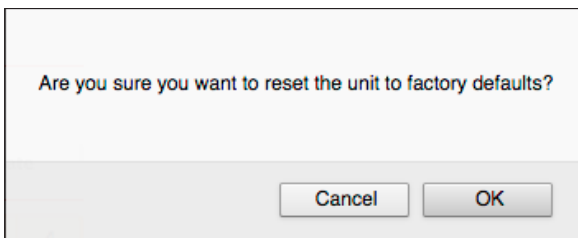

- Click the **OK** button to continue with the reset procedure.
- Click the **Cancel** button to abort the reset procedure and return to the web interface.

► **Rebooting the matrix**

Clicking this button will reboot the matrix.

1. Click the **Reboot** button.

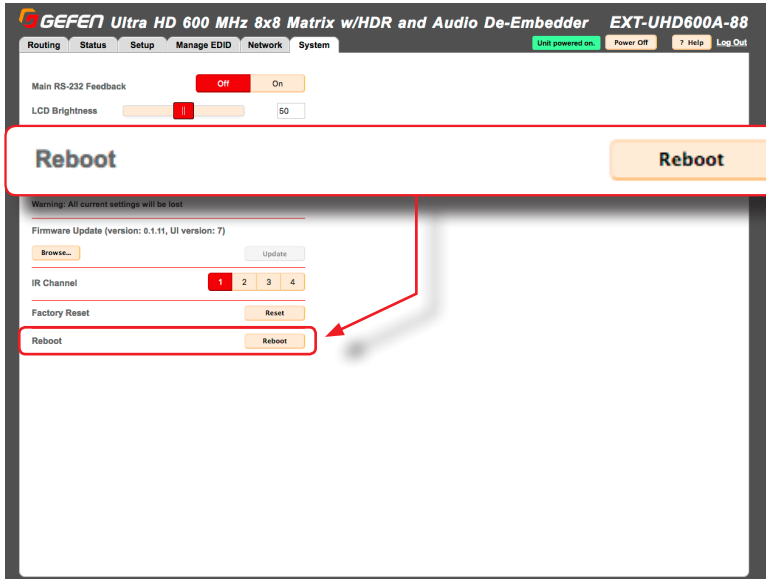

2. The following message box will be displayed:

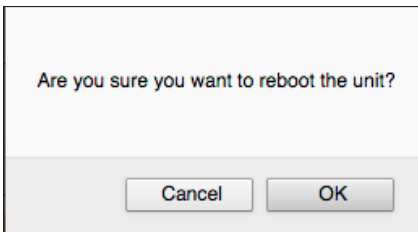

- Click the **OK** button to continue with the reboot procedure.
- Click the **Cancel** button to abort the reboot procedure and return to the web interface.

This page left intentionally blank.

This page left intentionally blank.

600 MHz
4K ULTRA 

8x8 Matrix

w/HDR and Audio De-Embedder

3

Advanced Operation

Telnet Configuration

1. Launch the desired terminal application. For example, on the Windows operation system, we can use Hyperterminal; on Mac OS X, we can use the Terminal application.

2. At the command prompt, type the following:

```
telnet ip_address
```

where `ip_address` is the IP address of the matrix.

3. After correct settings have been used in the terminal program, information similar to the following will be displayed:

```
Welcome to EXT-UHD600A-88 Telnet
```

```
telnet->
```

4. Type `#help` for a list of commands or refer to the tables on the following pages.

UDP Configuration

1. Configure the desired control system for UDP.
2. Click the **Network** tab, within the web interface, and do the following. See [Configuring Network Settings \(page 95\)](#) for more information.
 - a. Click the **Enabled** button next to UDP Access.
 - b. Enter the UDP listening port in the **UDP Port** field. The default UDP listening port is 50007.
 - c. Click the **Enabled** button next to **Remote UDP Access**. This feature only needs to be *enabled* if feedback to the matrix is required. Otherwise, this feature can be *disabled*.
 - d. If enabling Remote UDP Access, enter the remote UDP IP address in the **Remote UDP IP Address** field. This IP address should be the same as the control system. The default IP address is 192.168.1.255.
 - e. If enabling Remote UDP Access, enter the remote UDP listening port in the **Remote UDP Port** field. The default remote UDP listening port is 50008.
 - f. Click the **Save** button at the bottom of the **Network** screen.

RS-232 Configuration

1. Selected the desired COM port.
2. Configure the RS-232 port to the following settings. Note that Only TxD, RxD, and GND pins are used.

Description	Setting
Baud rate	19200
Data bits	8
Parity	None
Stop bits	1
Hardware flow control	None

3. Connect to the RS-232 port.
4. Type `#help` for a list of commands or refer to the tables on the following pages.

Discovery Service

Command	Description
#get_device_desc	Returns the current device-description string
#get_discovery	Returns the current state of the discovery service
#get_discovery_mode	Returns the “discovery” mode
#get_showme	Returns the “show me” state
#set_device_desc	Sets the description of the matrix
#set_discovery	Enables or disables the discovery service
#set_discovery_mode	Sets the “discovery” mode
#set_showme	Enables or disables the “show me” feature

Input Status

Command	Description
#gets_input_hdcp	Returns the HDCP setting of the specified input
#gets_input_hpd	Returns the HPD state of the specified input
#gets_input_mode	Returns the video mode of the specified input
#gets_input_signal	Returns the active signal state of the specified input

Manage EDID

Command	Description
#get_custom_edid	Download the custom EDID from the specified input
#get_edid_lock	Returns the EDID-lock status of the specified input
#get_edid_mode	Returns the EDID mode of the specified input
#get_external_edid	Download the modified external EDID
#get_input_edid	Download the current EDID from an input
#get_internal_edid	Downloads a preset internal EDID
#get_output_edid	Downloads a downstream EDID from an input
#send_custom_edid	Uploads a custom EDID to an input
#set_edid_copy	Enables or disables EDID copy
#set_edid_lock	Sets the EDID lock setting on the specified input
#set_edid_mode	Sets the EDID mode on the specified input

Network Settings

Command	Description
#get_gateway	Returns the gateway IP address of the matrix
#get_ip_address	Returns the IP address of the matrix
#get_ip_mode	Returns the IP mode of the matrix
#get_ipconfig	Returns the matrix IP configuration
#get_mac_addr	Returns the MAC address of the matrix
#get_netmask	Returns the subnet mask of the matrix
#get_remote_udp_access	Returns the remote UDP access state of the matrix
#get_remote_udp_ip	Returns the remote UDP IP address of the matrix
#get_remote_udp_port	Returns the remote UDP listening port
#get_telnet_access	Returns the Telnet access state
#get_telnet_login	Returns the current status of the Telnet login process
#get_telnet_message	Returns the Telnet login welcome message status
#get_telnet_port	Returns the Telnet listening port
#get_udp_access	Returns the UDP access state
#get_udp_port	Returns the UDP listening port
#get_web_port	Returns the HTTP listening port
#set_gateway	Sets the gateway address
#set_ip_address	Sets the IP address
#set_ip_mode	Sets the IP mode
#set_netmask	Sets the subnet mask for the matrix
#set_remote_udp_access	Enables or disables remote UDP access
#set_remote_udp_ip	Sets the remote UDP IP address
#set_remote_udp_port	Sets the remote UDP listening port on the matrix
#set_telnet_access	Enables or disables Telnet access
#set_telnet_login	Enables or disables the Telnet login process
#set_telnet_message	Enables or disable the Telnet welcome message
#set_telnet_port	Sets the Telnet listening port on the matrix
#set_udp_access	Enables or disables UDP access
#set_udp_port	Sets the UDP listening port on the matrix
#set_web_port	Sets the HTTP listening port

Output Status

Command	Description
<code>#gets_output_hdcp</code>	Returns the HDCP state of the specified output
<code>#gets_output_hpd</code>	Returns the HPD state of the specified output
<code>#gets_output_mode</code>	Returns the video mode of the specified output
<code>#gets_output_rsense</code>	Returns the output Rsense

Presets

Command	Description
<code>#get_preset_name</code>	Returns the name of the specified preset
<code>#set_preset_name</code>	Sets the name of the specified preset
<code>p</code>	Recalls the specified preset

Routing

Command	Description
<code>#get_mask</code>	Returns the mask status for the specified output(s)
<code>#lock_matrix</code>	Locks or unlocks the matrix
<code>#set_mask</code>	Sets masking on the specified output(s)
<code>r</code>	Routes an input to an output
<code>s</code>	Returns the current routing state for all inputs/outputs

Setup

Command	Description
#get_audio_output	Returns the audio mode for the specified output(s)
#get_input_hdcp	Returns the HDCP handshake more on an input
#get_io_name	Returns the name of the specified input
#get_output_hdcp	Returns the HDCP setting of the specified output
#send_hpd	Sends an HPD signal to the specified input
#set_audio_output	Sets analog audio mode for the specified output(s)
#set_input_hdcp	Sets the HDCP setting on the specified input
#set_io_name	Sets the name of the specified input or output
#set_output_hdcp	Sets the HDCP setting on the specified output

System Settings

Command	Description
#factory_reset	Resets the matrix to factory-default settings
#get_feedback	Returns the feedback state
#get_firmware_version	Returns the current version of matrix firmware
#get_ir_channel	Returns the current IR channel on the matrix
#get_lcd_brightness	Returns the current LED brightness setting
#help	Returns a list of available commands
#reboot	Reboots the matrix
#set_feedback	Enables or disables unsolicited RS-232 feedback
#set_ir_channel	Sets the IR channel of the matrix
#set_lcd_brightness	Sets the brightness of the LCD display

Volume

Command	Description
#get_mute	Returns the muting status for the specified output(s)
#get_vol	Returns the analog output volume for the output(s)
#set_mute	Sets the audio muting for the specified output(s)
#set_vol	Sets the analog output volume for the output(s)

#factory_reset

Resets the matrix to factory-default settings. If a factory reset is performed through the built-in web interface or Telnet, then IP settings will be preserved. To reset all, including IP settings, this command must be issued using RS-232.

Syntax

```
#factory_reset
```

Parameters

None

Example

```
#factory_reset  
RESET TO FACTORY DEFAULTS  
  
EXT-UHD600A-88 V1.00  
  
OUT:ABCDEFGH  
IN:12345678
```

Related Commands

```
#reboot
```

#get_audio_output

Returns the analog audio mode for the specified output(s). The value returned is one of the following:

Type	Description
F	Fixed
V	Variable

Syntax

```
#get_audio_output out
```

Parameters

Parameters

out

Type: **CHAR / INTEGER**

The alphabetic identifier of the output (A - H). Specify 0 to query all outputs; results are returned in output order A - H.

Example

```
#get_audio_output a  
AUDIO_OUTPUT A V
```

Related Commands

```
#set_audio_output
```

#get_custom_edid

Downloads the customer EDID from the specified input.

Syntax

```
#get_custom_edid input
```

Parameters

Parameters

input

Type: **INTEGER**

The number of the HDMI input (1 - 8).

Example

```
#get_custom_edid 1  
00FFFFFFFFFFFF001CA6000000000000...
```

Related Commands

```
#get_edid_lock  
#get_edid_mode  
#get_external_edid  
#get_input_edid  
#get_internal_edid  
#get_output_edid  
#send_custom_edid  
#set_edid_copy  
#set_edid_lock  
#set_edid_mode
```

#get_device_desc

Returns the description of the matrix.

Syntax

```
#get_device_desc
```

Parameters

None

Example

```
#get_device_desc  
DEVICE DESCRIPTION IS EXT-UHD600A-88
```

Related Commands

```
#set_device_desc
```

#get_discovery

Returns the discovery mode setting. The value returned is one of the following:

Value	Description
0	"Discovery" mode is disabled
1	"Discovery" mode is enabled

Syntax

```
#get_discovery
```

Parameters

None

Example

```
#get_discovery  
DISCOVERY 1
```

Related Commands

```
#set_discovery  
#set_showme
```

#get_discovery_mode

Returns the current “discovery” mode. The value returned is one of the following:

Value	Description
0	Read only
1	Read / Write

Syntax

```
#get_discovery_mode
```

Parameters

None

Example

```
#get_discovery_mode  
#get_discovery_mode 1
```

Related Commands

```
#get_discovery  
#set_discovery  
#set_discovery_mode
```

#get_edid_lock

Returns the current “EDID Lock” state of the specified input. The value returned is one of the following:

Value	Description
0	EDID unlocked
1	EDID locked

Syntax

```
#get_edid_lock input
```

Parameters

input

Type: **INTEGER**

The number of the HDMI input (1 - 8) to query.

Example

```
#get_edid_lock 1  
EDID_LOCK 1 0
```

Related Commands

```
#get_edid_mode  
#set_edid_copy  
#set_edid_lock  
#set_edid_mode
```

#get_edid_mode

Returns the EDID mode of the specified input. The value returned is one of the following:

Value	Description
1	UHD 4K 600 MHz 2Ch
2	UHD 4K 600 MHz Multi
3	UHD 4K 300 MHz 2Ch
4	UHD 4K 600 MHz Multi
5	1080P 2Ch
6	1080 Multi
7	External
8	Custom - User

Syntax

```
#get_edid_mode input
```

Parameters

input

Type: **INTEGER**

The number of the HDMI input (1 - 8) to query.

Example

```
#get_edid_mode 1
#get_edid_mode 1 2
```

Related Commands

```
#get_edid_lock
#set_edid_copy
#set_edid_lock
#set_edid_mode
```

#get_external_edid

Returns the modified external EDID.

Syntax

```
#get_external_edid
```

Parameters

None

Example

```
#get_external_edid  
00FFFFFFFFFFFFFF001CA6000000000000...
```

Related Commands

```
#get_custom_edid  
#get_edid_lock  
#get_edid_mode  
#get_input_edid  
#get_internal_edid  
#get_output_edid  
#send_custom_edid  
#set_edid_copy  
#set_edid_lock  
#set_edid_mode
```

#get_feedback

Returns the feedback status.

Syntax

```
#get_feedback
```

Parameters

None

Example

```
#get_feedback  
FEEDBACK 1
```

Related Commands

```
#factory_reset  
#get_firmware_version  
#get_ir_channel  
#get_lcd_brightness  
#help  
#reboot  
#set_feedback  
#set_ir_channel  
#set_lcd_brightness
```

#get_firmware_version

Returns the current firmware version of the matrix.

Syntax

```
#get_firmware_version
```

Parameters

None

Example

```
#get_firmware_version  
FIRMWARE VERSION IS 1.0
```

Related Commands

```
#factory_reset  
#get_feedback  
#get_ir_channel  
#get_lcd_brightness  
#help  
#reboot  
#set_feedback  
#set_ir_channel  
#set_lcd_brightness
```

#get_gateway

Returns the gateway address of the matrix.

Syntax

```
#get_gateway
```

Parameters

None

Example

```
#get_gateway  
GATEWAY 10.5.64.1
```

Related Commands

```
#get_web_port  
#get_ip_address  
#get_ip_mode  
#get_ipconfig  
#get_mac_addr  
#get_netmask  
#set_gateway  
#set_web_port  
#set_ip_address  
#set_ip_mode  
#set_netmask
```

#get_input_edid

Returns the current EDID from the specified input.

Syntax

```
#get_input_edid input
```

Parameters

input

Type: **INTEGER**

The number of the HDMI input (1 - 8) to query.

Example

```
#get_input_edid  
00FFFFFFFFFFFF001CA6000000000000...
```

Related Commands

```
#get_custom_edid  
#get_external_edid  
#get_edid_lock  
#get_edid_mode  
#get_internal_edid  
#get_output_edid  
#send_custom_edid  
#set_edid_copy  
#set_edid_lock  
#set_edid_mode
```

#get_input_hdcp

Returns the HDCP handshake mode of the specified input.

Syntax

```
#get_input_hdcp
```

Parameters

input

Type: **INTEGER**

The number of the HDMI input (1 - 8) to query. Set this parameter to 0 to return the HDCP handshake mode of all inputs in numerical order.

Example

```
#get_input_hdcp 1  
INPUT_HDCP 1 2
```

Related Commands

```
#set_input_hdcp
```

#get_internal_edid

Returns the specified preset internal EDID.

Syntax

```
#get_internal_edid edidps
```

Parameters

edidps

Type: **INTEGER**

The number of the EDID preset.

EDID	Description
1	UHD 600 4K 2CH
2	UHD 600 4K MULTICH
3	UHD 300 4K 2CH
4	UHD 300 4K MULTICH
5	1080P 2CH
6	1080P MULTICH

Example

```
#get_internal_edid 1  
00FFFFFFFFFFFF001CA6000000000000...
```

#get_io_name

Returns the name given to the specified input or output.

Syntax

```
#get_io_name inout
```

Parameters

input

Type: **INTEGER** or **CHARACTER**

The number of the HDMI input (1 - 8) to query.

Example

```
#get_io_name 1  
IO_NAME 1 Bluray
```

Related Commands

```
#set_io_name
```

#get_ip_address

Returns the current IP address of the matrix.

Syntax

```
#get_ip_address
```

Parameters

None

Example

```
#get_ip_address  
IP_ADDRESS 10.5.64.81
```

Related Commands

```
#get_gateway  
#get_web_port  
#get_ip_mode  
#get_ipconfig  
#get_mac_addr  
#get_netmask  
#set_gateway  
#set_web_port  
#set_ip_address  
#set_ip_mode  
#set_netmask
```

#get_ip_mode

Returns the current IP mode of the matrix. The value returned is one of the following:

Value	Description
0	Static mode
1	DHCP mode

Syntax

```
#get_ip_mode
```

Parameters

None

Example

```
#get_ip_mode  
IP_MODE 0
```

Related Commands

```
#get_gateway  
#get_web_port  
#get_ip_address  
#get_ipconfig  
#get_mac_addr  
#get_netmask  
#set_gateway  
#set_web_port  
#set_ip_address  
#set_ip_mode  
#set_netmask
```

#get_ipconfig

Returns the current IP configuration of the matrix. In addition to providing the MAC address and the broadcast IP address, this command also provides the same information as executing the #get_ip_address, #get_netmask, #get_gateway, and #get_mac_addr ommands.

Syntax

```
#get_ipconfig
```

Parameters

None

Example

```
#get_ipconfig
IP CONFIGURATION IS :
IP: 10.5.64.81
NETMASK: 255.255.255.0
GATEWAY: 10.5.64.1
MAC ADDRESS: 00:1C:91:04:90:03
```

Related Commands

```
#get_gateway
#get_web_port
#get_ip_mode
#get_ip_address
#get_mac_addr
#get_netmask
#set_gateway
#set_web_port
#set_ip_address
#set_ip_mode
#set_netmask
```

#get_ir_channel

Returns the IR channel of the matrix.

Syntax

```
#get_ir_channel
```

Parameters

None

Example

```
#get_ir_channel  
IR_CHANNEL 1
```

Related Commands

```
#set_ir_channel
```

#get_lcd_brightness

Returns the brightness level of the LED indicators on the front panel.

Syntax

```
#get_lcd_brightness
```

Parameters

None

Example

```
#get_lcd_brightness  
LCD_BRIGHTNESS 60
```

Related Commands

```
#set_lcd_brightness
```

#get_mac_addr

Returns the MAC address of the matrix.

Syntax

```
#get_mac_addr
```

Parameters

None

Example

```
#get_mac_addr  
MAC ADDRESS IS: 00:1C:91:04:90:03
```

Related Commands

```
#get_gateway  
#get_web_port  
#get_ip_address  
#get_ip_mode  
#get_ipconfig  
#get_netmask  
#set_gateway  
#set_web_port  
#set_ip_address  
#set_ip_mode  
#set_netmask
```

#get_mask

Returns the mask state for the specified output(s).

Syntax

```
#get_mask output
```

Parameters

output

Type: **CHAR / INTEGER**

The alphabetic identifier of the output (A - H). Specify 0 to query all outputs; results are returned in output order A - H.

Example

```
#get_mask a  
MASK A 0
```

Related Commands

#get_mute

Returns the audio muting status for the specified output(s).

Syntax

```
#get_mute output
```

Parameters

output

Type: **INTEGER**

The alphabetic identifier of the output (A - H). Specify 0 to query all outputs; results are returned in output order A - H.

Example

```
#get_mute A  
#get_mute 0
```

Related Commands

#get_netmask

Returns the current subnet mask of the matrix.

Syntax

```
#get_netmask
```

Parameters

None

Example

```
#get_netmask  
NETMASK 255.255.255.0
```

Related Commands

```
#get_gateway  
#get_web_port  
#get_ip_address  
#get_ip_mode  
#get_ipconfig  
#get_mac_addr  
#set_gateway  
#set_web_port  
#set_ip_address  
#set_ip_mode  
#set_netmask
```

#get_output_edid

Returns the downstream EDID from the specified output.

Syntax

```
#get_output_edid output
```

Parameters

output

Type: **CHAR**

The alphabetic identifier of the output (A - H).

Example

```
#get_output_edid a  
00FFFFFFFFFFFF001CA6000000000000...
```

Related Commands

#get_output_hdcp

Returns the HDCP setting of the specified output. The value returned is one of the following:

Value	Description
0	Follow input
1	Always encode

Syntax

```
#get_output_hdcp output
```

Parameters

output

Type: **CHARACTER**

The identifier of the HDMI output (A - H) to query. Specify 0 to query all outputs; results are returned in output order A - H.

Example

```
#get_output_hdcp c  
OUTPUT_HDCP C 1
```

Related Commands

```
#set_output_hdcp
```

#get_preset_name

Returns the name of the specified preset.

Syntax

```
#get_preset_name preset
```

Parameters

preset

Type: **INTEGER**

The identifier of the preset name (1 - 16) to query.

Example

```
#get_preset_name 5  
PRESET_NAME 5 Kitchen
```

Related Commands

```
#set_preset_name
```

#get_remote_udp_access

Returns the remote UDP access state. The value returned is one of the following:

Value	Description
0	Remote UDP access disabled
1	Remote UDP access enabled

Syntax

```
#get_remote_udp_access
```

Parameters

None

Example

```
#get_remote_udp_access  
REMOTE_UDP_ACCESS 0
```

Related Commands

```
#get_remote_udp_ip  
#get_remote_udp_port  
#get_udp_access  
#get_udp_port  
#set_remote_udp_access  
#set_remote_udp_ip  
#set_remote_udp_port  
#set_udp_access  
#set_udp_port
```

#get_remote_udp_ip

Returns the remote UDP IP address.

Syntax

```
#get_remote_udp_ip
```

Parameters

None

Example

```
#get_remote_udp_access  
REMOTE_UDP_IP 192.168.1.255
```

Related Commands

```
#get_remote_udp_access  
#get_remote_udp_port  
#get_udp_access  
#get_udp_port  
#set_remote_udp_access  
#set_remote_udp_ip  
#set_remote_udp_port  
#set_udp_access  
#set_udp_port
```

#get_remote_udp_port

Returns the remote UDP listening port.

Syntax

```
#get_remote_udp_port
```

Parameters

None

Example

```
#get_remote_udp_port  
REMOTE_UDP_PORT 50008
```

Related Commands

```
#get_remote_udp_access  
#get_remote_udp_ip  
#get_udp_access  
#get_udp_port  
#set_remote_udp_access  
#set_remote_udp_ip  
#set_remote_udp_port  
#set_udp_access  
#set_udp_port
```

#get_showme

Returns the “showme” state.

Value	Description
0	Show me disabled
1	Show me enabled

Syntax

```
#get_showme
```

Parameters

None

Example

```
#get_showme  
SHOW_ME 0
```

Related Commands

#get_telnet_access

Returns the Telnet access state. Use the #set_telnet_access command to enable or disable Telnet access.

Syntax

```
#get_telnet_access
```

Parameters

None

Example

```
#get_telnet_access  
TELNET_ACCESS 1
```

Related Commands

```
#get_telnet_port  
#get_telnet_message  
#set_telnet_access  
#set_telnet_port  
#set_telnet_message
```

#get_telnet_login

Returns the status of the Telnet login process.

Syntax

```
#get_telnet_login
```

Parameters

None

Example

```
#get_telnet_login  
TELNET_LOGIN 0
```

Related Commands

#get_telnet_message

Returns the Telnet welcome message. Use the #set_telnet_message to create a custom welcome message.

Syntax

```
#get_telnet_message
```

Parameters

None

Example

```
#get_telnet_message  
TELNET WELCOME SCREEN IS ENABLED
```

Related Commands

```
#get_telnet_access  
#get_telnet_port  
#set_telnet_access  
#set_telnet_port  
#set_telnet_message
```

#get_telnet_port

Returns the Telnet listening port.

Syntax

```
#get_telnet_port
```

Parameters

None

Example

```
#get_telnet_port  
TELNET_PORT 23
```

Related Commands

```
#get_telnet_access  
#get_telnet_message  
#set_telnet_access  
#set_telnet_port  
#set_telnet_message
```

#get_udp_access

Returns the UDP access state. Use the `#set_udp_access` command to enable or disable UDP access. The value returned is one of the following:

Value	Description
0	UDP access disabled
1	UDP access enabled

Syntax

```
#get_udp_access
```

Parameters

None

Example

```
#get_udp_access  
UDP_ACCESS 0
```

Related Commands

```
#get_remote_udp_access  
#get_remote_udp_ip  
#get_remote_udp_port  
#get_udp_port  
#set_remote_udp_access  
#set_remote_udp_ip  
#set_remote_udp_port  
#set_udp_access  
#set_udp_port
```

#get_udp_port

Returns the local UDP listening port.

Syntax

```
#get_udp_port
```

Parameters

None

Example

```
#get_udp_port  
UDP_PORT 50007
```

Related Commands

```
#get_remote_udp_access  
#get_remote_udp_ip  
#get_remote_udp_port  
#get_udp_access  
#set_remote_udp_access  
#set_remote_udp_ip  
#set_remote_udp_port  
#set_udp_access  
#set_udp_port
```

#get_vol

Returns the analog output volume level for the specified output(s).

Syntax

```
#get_vol output
```

Parameters

output

Type: **CHAR / INTEGER**

The alphabetic identifier of the output (A - H). Specify 0 to query all outputs; results are returned in output order A - H.

Example

```
#get_vol a  
VOL A 100
```

Related Commands

#get_web_port

Returns the HTTP listening port of the matrix.

Syntax

```
#get_web_port
```

Parameters

None

Example

```
#get_web_port  
HTTP_PORT 80
```

Related Commands

```
#get_gateway  
#get_ip_address  
#get_ip_mode  
#get_ipconfig  
#get_mac_addr  
#get_netmask  
#set_gateway  
#set_web_port  
#set_ip_address  
#set_ip_mode  
#set_netmask
```

#gets_input_hdcp

Returns the HDCP mode of the specified input. The value returned is one of the following:

Value	Description
0	Reject
1	HDCP 2.2 and below
2	HDCP 1.4 and below

Syntax

```
#gets_input_hdcp input
```

Parameters

input

Type: **INTEGER**

The number of the HDMI input (1 - 8) to query. Specify 0 to query all inputs; results are returned in input order 1 - 8.

Example

```
#gets_input_hdcp 1  
INPUT_HDCP 1 0
```

Related Commands

```
#get_output_hdcp  
#set_input_hdcp  
#set_output_hdcp
```

#gets_input_hpd

Returns the HPD state of the specified input. The value returned is one of the following:

Value	Description
L	HPD low
H	HPD high

Syntax

```
#gets_input_hpd input
```

Parameters

input

Type: **INTEGER**

The number of the HDMI input (1 - 8) to query. Specify 0 to query all inputs; results are returned in numerical order.

Example

```
#gets_input_hpd 1  
INPUT_HDCP 1 0
```

Related Commands

#gets_input_mode

Returns the video mode of the specified input.

Syntax

```
#gets_input_mode input
```

Parameters

input

Type: **INTEGER**

The number of the HDMI input (1 - 8) to query. Specify 0 to query all inputs; results are returned in input order 1 - 8.

Example

```
#gets_input_mode 1  
INPUT_MODE 1 C
```

Related Commands

#gets_input_signal

Returns the active signal status of the specified input.

Syntax

```
#gets_input_signal input
```

Parameters

input

Type: **INTEGER**

The number of the HDMI input (1 - 8) to query. Specify 0 to query all inputs; results are returned in input order 1 - 8.

Example

```
#gets_input_signal 1  
INPUT_SIGNAL 1 Y
```

#gets_output_hdcp

Returns the HDCP status of the specified output. The value returned will be one of the following:

Value	Description
1	Encrypted (HDCP 1.4)
2	Encrypted (HDCP 2.2)
U	Unencrypted
F	Fail

Syntax

```
#gets_output_hdcp output
```

Parameters

output

Type: **CHAR / INTEGER**

The alphabetic identifier of the output (A - H). Specify 0 to query all outputs; results are returned in output order A - H.

Example

```
#gets_output_hdcp a  
OUTPUT_HDCP A 2
```

#gets_output_hpd

Returns the HPD status of the specified output. The value returned will be one of the following:

Value	Description
L	HPD low
H	HPD high

Syntax

```
#gets_output_hpd output
```

Parameters

output

Type: **CHAR / INTEGER**

The alphabetic identifier of the output (A - H). Specify 0 to query all outputs; results are returned in output order A - H.

Example

```
#gets_output_hpd a  
OUTPUT_HPD A H
```

#gets_output_mode

Returns the video output mode of the specified output. The value returned will be one of the following:

Value	Description
D	DVI signal detected
H	HDMI signal detected

Syntax

```
#gets_output_mode output
```

Parameters

output

Type: **CHAR / INTEGER**

The alphabetic identifier of the output (A - H). Specify 0 to query all outputs; results are returned in output order A - H.

Example

```
#gets_output_mode a  
OUTPUT_MODE A H
```

#gets_output_rsense

Returns the Rsense state of the specified output(s). The value returned will be one of the following:

Value	Description
L	Rsense low
H	Rsense high

Syntax

```
#gets_output_rsense output
```

Parameters

output

Type: **CHAR / INTEGER**

The alphabetic identifier of the output (A - H). Specify 0 to query all outputs; results are returned in output order A - H.

Example

```
#gets_output_rsense a  
OUTPUT_RSENSE A L
```

#help

Returns a list of available commands. The commands listed are specific to either the Sender or Receiver unit.

Syntax

```
#help
```

Parameters

None

Example

```
#help
```

```
[HELP]  
#HELP
```

```
[VOLUME]  
#GET_MUTE  
#GET_VOL  
#SET_MUTE  
#SET_VOL
```

```
[ROUTING]  
#GET_MASK  
#LOCK_MATRIX  
#SET_MASK  
R  
S  
...  
...  
...
```

#lock_matrix

Locks or unlocks the matrix. This command locks the front panel and the built-in web interface of the matrix. Note that if the matrix is locked, settings can still be changed using the command set.

Syntax

```
#lock_matrix state
```

Parameters

state

Type: **INTEGER**

Accepts a number from the table below, specifying the desired state:

state	Description
0	Unlocks the matrix
1	Locks the matrix

Example

```
#lock_matrix 1  
LOCK_MATRIX 1
```

#reboot

Reboots the matrix.

Syntax

```
#reboot
```

Parameters

None

Example

```
#reboot  
UNIT WILL REBOOT SHORTLY
```

Related Commands

```
#factory_reset
```

#send_custom_edid

Uploads a custom EDID to the specified input. The input must first be set to CUSTOM MODE.

Syntax

```
#send_custom_edid input
```

Parameters

input

Type: **INTEGER**

The numeric identifier of the input (1 - 8).

Example

```
#send_custom_edid 1  
SEND_COMPLETE
```

#send_hpd

Sends an HPD (Hot-Plug Detect) pulse to the specified input.

Syntax

```
#send_hpd input
```

Parameters

input

Type: **INTEGER**

The identifier of the HDMI input (1 - 8) where the HPD pulse will be sent. Set this parameter to 0 to send the HPD pulse to all inputs.

Example

```
#send_hpd 1  
HPD SENT
```

#set_audio_output

Sets the analog audio mode for the specified output(s).

Syntax

```
#set_audio_output output audtype
```

Parameters

output

Type: **CHAR / INTEGER**

The alphabetic identifier of the output (A - H). Set this parameter to 0 to set all outputs to the same audio mode. Feedback lists all analog audio modes for outputs in order A - H.

audtype

Type: **CHAR**

The method of how the analog output will be sent to the output. Accepts a value from the table below.

Type	Description
F	Fixed
V	Variable

Example

```
#set_audio_output a f  
AUDIO OUTPUT A F
```

Related Commands

```
#get_audio_output
```

#set_device_desc

Sets the matrix identifier string.

Syntax

```
#set_device_desc name
```

Parameters

name

Type: **STRING**

The device description. This value cannot exceed 30 characters in length.

Example

```
#set_device_desc matrix8x8  
DEVICE DESCRIPTION IS SET TO matrix8x8
```

Related Commands

```
#get_device_desc
```

#set_discovery

Enables or disables the “discovery” feature. This feature is *enabled* by default.

Syntax

```
#set_discovery state
```

Parameters

state

Type: **INTEGER**

Accepts a number from the table below, specifying the desired state:

state	Description
0	Disables “Discovery” mode
1	Enables “Discovery” mode

If set to *disabled*, then the Syner-G Software Suite will be unable to detect the matrix on a network. It is recommended that this feature is *enabled*, until the matrix has been configured for use on a network.

Example

```
#set_discovery 0  
DISCOVERY 0
```

Related Commands

```
#get_discovery  
#get_discovery_mode  
#set_discovery_mode
```

#set_discovery_mode

Sets the “discovery” mode. This mode is set to *read/write* by default.

Syntax

```
#set_discovery_mode mode
```

Parameters

mode

Type: **INTEGER**

Accepts a number from the table below, specifying the desired state:

mode	Description
0	Read-only mode
1	Read / write mode

When set to *read-only* mode, the IP settings for the matrix will be displayed within the Gefen Syner-G Software Suite but cannot be changed. In order to both display and allow changes to the IP settings within Gefen Syner-G, set this feature to *read/write* mode.

Example

```
#set_discovery_mode 0  
DISCOVERY MODE 0
```

Related Commands

```
#get_discovery  
#get_discovery_mode  
#set_discovery
```

#set_edid_copy

Copies the EDID from output or input to the selected input for use in custom EDID mode. In order for an EDID to be copied, the destination input port must be set to Custom mode and must not be locked. See [Copying EDID Data \(page 89\)](#) for more information.

Syntax

```
#set_edid_copy inout input [...input]
```

Parameters

inout

Type: **INTEGER** or **CHARACTER**

This parameter can accept either the identifier of an HDMI input (1 - 8) or an HDMI output (A - H). Only a single input or output can be specified at a time.

input

Type: **INTEGER**

This parameter must be the identifier of an HDMI input (1 - 8). Multiple inputs can be specified.

Example

```
#set_edid_copy a 1
EDID_COPY a 1

#set_edid_copy b 2 5
EDID_COPY b 2 5
```

Related Commands

```
#get_edid_lock
#get_edid_mode
#set_edid_lock
#set_edid_mode
```

#set_edid_lock

Locks to unlocks the EDID when using Custom EDID mode. This command only works if the specified input is set to Custom. See the #set_edid_mode command.

Syntax

```
#set_edid_lock input state
```

Parameters

input

Type: **INTEGER**

This parameter must be the identifier of an HDMI input (1 - 8).

state

Type: **INTEGER**

Accepts a number from the table below, specifying the desired state:

state	Description
0	Unlock the EDID
1	Lock the EDID

Example

```
#set_edid_lock 1 0  
SET_EDID_LOCK 1 0
```

Related Commands

```
#get_edid_lock  
#get_edid_mode  
#set_edid_copy  
#set_edid_mode
```

#set_edid_mode

Sets the EDID mode for the specified input.

Syntax

```
#set_edid_mode input mode
```

Parameters

input

Type: **INTEGER**

This parameter must be the identifier of an HDMI input (1 - 8).

mode

Type: **INTEGER**

Accepts a number from the table below, corresponding to the desired EDID.

mode	Description
1	UHD 4K 600 MHz 2Ch
2	UHD 4K 600 MHz Multi
3	UHD 4K 300 MHz 2Ch
4	UHD 4K 600 MHz Multi
5	1080P 2Ch
6	1080 Multi
7	External
8	Custom - User

Example

```
#set_edid_mode 1 2
EDID_MODE 1 2
```

Related Commands

```
#get_edid_lock
#get_edid_mode
#set_edid_copy
#set_edid_lock
```

#set_feedback

Enables or disables unsolicited RS-232 feedback.

Syntax

```
#set_feedback state
```

Parameters

state

Type: **INTEGER**

Accepts a number from the table below, specifying the desired state:

state	Description
0	Disable RS-232 feedback
1	Enable RS-232 feedback

Example

```
#set_feedback 1  
SET_FEEDBACK 1
```

#set_gateway

Sets the gateway address for the matrix. The gateway address will be changed only if the matrix is in *static* IP mode. If the matrix is using *DHCP* mode, then the gateway address is automatically assigned by the DHCP server. The matrix must be rebooted after executing this command.

Syntax

```
#set_gateway addr
```

Parameters

addr

Type: **IP ADDRESS**

The desired gateway address of the matrix. This address must be entered in dot-decimal notation.

Example

```
#set_gateway 10.5.64.1
GATEWAY 10.5.64.1
REBOOT TO APPLY SETTINGS
```

Related Commands

```
#get_gateway
#get_web_port
#get_ip_address
#get_ip_mode
#get_ipconfig
#get_mac_addr
#get_netmask
#set_web_port
#set_ip_address
#set_ip_mode
#set_netmask
```

#set_input_hdcp

Sets the HDCP mode on the specified input.

Syntax

```
#set_input_hdcp input mode
```

Parameters

input

Type: **INTEGER**

Accepts the number of an HDMI input (1 - 8). Set this parameter to 0 to apply the HDCP setting to all inputs. Feedback lists all HDCP settings for inputs in order 1 - 8.

mode

Type: **INTEGER**

Accepts a number from the table below, corresponding to the desired HDCP mode.

mode	Description
0	Reject HDCP content
1	Allow HDCP version 2.2 and below
2	Allow HDCP version 1.4 and below

Example

```
#set_input_hdcp 1
INPUT_HDCP 1 0
```

Related Commands

```
#gets_input_hdcp
#get_output_hdcp
#set_output_hdcp
```

#set_io_name

Sets the name of the specified input.

Syntax

```
#set_io_name inout name
```

Parameters

inout

Type: **INTEGER** or **CHARACTER**

This parameter can accept either the number of an HDMI input (1 - 8) or the identifier of an HDMI output (A - H). Only one input or output can be specified at one time.

name

Type: **STRING**

The desired name of the specified input / output. The length of the string cannot exceed 30 characters. Strings greater than 30 characters in length will be rejected.

Example

```
#set_io_name 1 Bluray  
IO_NAME 1 Bluray
```

```
#set_io_name d BIG_screen  
IO_NAME D BIG_screen
```

Related Commands

```
#get_io_name
```

#set_ip_address

Sets the IP address of the matrix. The matrix must be rebooted after executing this command.

Syntax

```
#set_ip_address addr
```

Parameters

addr

Type: **IP ADDRESS**

The desired IP address of the matrix. This address must be entered in dot-decimal notation.

Example

```
#set_ip_address 10.5.64.81
IP_ADDRESS 10.5.64.81
REBOOT TO APPLY SETTINGS
```

Related Commands

```
#get_gateway
#get_web_port
#get_ip_address
#get_ip_mode
#get_ipconfig
#get_mac_addr
#get_netmask
#set_gateway
#set_web_port
#set_ip_mode
#set_netmask
```

#set_ip_mode

Sets the IP mode of the matrix. The matrix must be rebooted after executing this command.

Syntax

```
#set_ip_mode mode
```

Parameters

mode

Type: **INTEGER**

Accepts a number from the table below, corresponding to the desired IP mode.

mode	Description
0	Static
1	DHCP
2	Auto

Example

```
#set_ip_mode 1  
IP MODE 1  
REBOOT TO APPLY SETTINGS
```

Related Commands

```
#get_gateway  
#get_web_port  
#get_ip_address  
#get_ip_mode  
#get_ipconfig  
#get_mac_addr  
#get_netmask  
#set_gateway  
#set_web_port  
#set_ip_address  
#set_netmask
```

#set_ir_channel

Sets the IR channel of the matrix. In order to use the included IR remote control with the matrix, both the matrix and the IR remote control must be set to the same IR channel.

Syntax

```
#set_ir_channel irch
```

Parameters

irch

Type: **INTEGER**

Accepts a number from the table below, corresponding to the desired IR channel.

irch	Description
1	IR channel 1
2	IR channel 2
3	IR channel 3
4	IR channel 4

Example

```
#set_ir_channel 2  
IR_CHANNEL 2
```

Related Commands

```
#get_ir_channel
```

#set_lcd_brightness

Sets the brightness level of the LCD display on the front panel of the matrix.

Syntax

```
#set_lcd_brightness level
```

Parameters

level

Type: **INTEGER**

Accepts a number within the range of 0 - 100. The value of 100 represents the brightest setting of the display.

Example

```
#set_lcd_brightness 75  
LCD_BRIGHTNESS 75
```

Related Commands

```
#get_lcd_brightness
```

#set_mask

Sets the masking for the specified output(s).

Syntax

```
#set_mask output state
```

Parameters

output

Type: **CHAR / INTEGER**

The alphabetic identifier of the output (A - H). Set this parameter to 0 to set all outputs to the same masking state. Feedback lists all output masking states in order A - H.

state

Type: **INTEGER**

The masking state. Accepts a value from the table below.

State	Description
0	Unmask
1	Mask

Example

```
#set_mask a 1  
MASK A 1
```

Related Commands

```
#get_mask
```

#set_mute

Sets the audio muting state for the specified output(s).

Syntax

```
#set_mute output
```

Parameters

output

Type: **CHAR / INTEGER**

The alphabetic identifier of the output (A - H). Set this parameter to 0 to set all outputs to the same muting state. Feedback lists all output muting states in order A - H.

state

Type: **INTEGER**

The muting state. Accepts a value from the table below.

State	Description
0	Unmute
1	Mute

Example

```
#set_mute a 0  
MUTE A 0
```

Related Commands

```
#get_mute
```

#set_netmask

Sets the network mask address. The matrix must be rebooted after executing this command.

Syntax

```
#set_netmask addr
```

Parameters

addr

Type: **ADDRESS**

The desired subnet mask of the matrix. This address must be entered in dot-decimal notation.

Example

```
#set_netmask 255.255.255.0  
NETMASK 255.255.255.0  
REBOOT TO APPLY SETTINGS
```

Related Commands

```
#get_gateway  
#get_web_port  
#get_ip_address  
#get_ip_mode  
#get_ipconfig  
#get_mac_addr  
#get_netmask  
#set_gateway  
#set_web_port  
#set_ip_address  
#set_ip_mode
```

#set_output_hdcp

Sets the HDCP mode on the specified output.

Syntax

```
#set_output_hdcp output mode
```

Parameters

output

Type: **CHARACTER**

Accepts the identifier of an HDMI output (A - H). Set this parameter to 0 to set all outputs to the same HDCP mode. Feedback lists all HDCP mode for outputs in order A - H.

mode

Type: **INTEGER**

Accepts a number, from table below, corresponding to the desired HDCP mode.

mode	Description
0	Follow Input
1	Always Encode

Example

```
#set_output_hdcp a 0
OUTPUT_HDCP A 0
```

Related Commands

```
#gets_input_hdcp
#get_output_hdcp
#set_input_hdcp
```

#set_preset_name

Assigns a name to the specified preset.

Syntax

```
#set_preset_name preset name
```

Parameters

preset

Type: **INTEGER**

Accepts the identifier of a Preset (1 - 16).

name

Type: **STRING**

The name of the preset. The name must not exceed 12 characters in length.

No special characters (e.g. #,@,*,&,% , etc.) are allowed. Spaces are permitted.

Example

```
#set_preset_name 1 LivingRoom  
PRESET_NAME 1 LivingRoom
```

Related Commands

```
#get_preset_name
```

#set_remote_udp_access

Enables or disables remote UDP access.

Syntax

```
#set_remote_udp_access state
```

Parameters

state

Type: **INTEGER**

Accepts a number from the table below, corresponding to the desired state.

state	Description
0	Disable remote UDP access
1	Enable remote UDP access

Example

```
#set_remote_udp_access 0  
REMOTE_UDP_ACCESS 0
```

Related Commands

```
#get_remote_udp_access  
#get_remote_udp_ip  
#get_remote_udp_port  
#get_udp_access  
#get_udp_port  
#set_remote_udp_ip  
#set_remote_udp_port  
#set_udp_access  
#set_udp_port
```

#set_remote_udp_ip

Sets the remote UDP IP address of the matrix.

Syntax

```
#set_remote_udp_ip addr
```

Parameters

addr

Type: **IP ADDRESS**

The desired remote UDP IP address of the matrix. The address must be entered in dot-decimal notation.

Example

```
#set_remote_udp_ip 192.168.1.251  
REMOTE_UDP_IP 192.168.1.251
```

Related Commands

```
#get_remote_udp_access  
#get_remote_udp_ip  
#get_remote_udp_port  
#get_udp_access  
#get_udp_port  
#set_remote_udp_access  
#set_remote_udp_port  
#set_udp_access  
#set_udp_port
```

#set_remote_udp_port

Sets the remote UDP listening port for the matrix.

Syntax

```
#set_remote_udp_port port
```

Parameters

port

Type: **INTEGER**

The desired remote UDP port (0 - 65535) of the matrix.

Example

```
#set_remote_udp_port 50008  
REMOTE_UDP_PORT 50008
```

Related Commands

```
#get_remote_udp_access  
#get_remote_udp_ip  
#get_remote_udp_port  
#get_udp_access  
#get_udp_port  
#set_remote_udp_access  
#set_remote_udp_ip  
#set_udp_access  
#set_udp_port
```

#set_showme

Enables or disables the “Show Me” feature. If the “Show Me” feature is enabled, then all the buttons (with the exception of the Power button), will flash slowly. This feature allows the matrix to be visually identified on the network and is useful when multiple matrix units are being used. The default setting is *disabled*.

Syntax

```
#set_showme state
```

Parameters

state

Type: **INTEGER**

Accepts a number from the table below, corresponding to the desired state.

state	Description
0	Disable “Show Me”
1	Enable “Show Me”

Example

```
#set_showme 1  
SET_SHOWME 1
```

Related Commands

```
#get_discovery  
#set_discovery
```

#set_telnet_access

Enables or disables Telnet access on the matrix.

Syntax

```
#set_telnet_access state
```

Parameters

state

Type: **INTEGER**

Accepts a number from the table below, corresponding to the desired state.

state	Description
0	Disable Telnet access
1	Enable Telnet access

Example

```
#set_telnet_access 1  
TELNET_ACCESS 1
```

Related Commands

```
#get_telnet_access  
#get_telnet_port  
#get_telnet_message  
#set_telnet_port  
#set_telnet_message
```

#set_telnet_login

Enable or disable the Telnet login process. When disabled, login credentials are not required.

Syntax

```
#set_telnet_login state
```

Parameters

state

Type: **INTEGER**

Accepts a number, from table below, corresponding to the desired state.

state	Description
0	Disable login process
1	Enable login process

Example

```
#set_telnet_login
```

Related Commands

```
#get_telnet_access  
#get_telnet_port  
#get_telnet_message  
#set_telnet_access  
#set_telnet_message
```

#set_telnet_message

Enables or disables the Telnet welcome message.

Syntax

```
#set_telnet_message state
```

Parameters

state

Type: **INTEGER**

Accepts a number, from table below, corresponding to the desired state.

state	Description
0	Disable welcome message
1	Enable welcome message

Example

```
#set_telnet_message
```

Related Commands

```
#get_telnet_access  
#get_telnet_port  
#get_telnet_message  
#set_telnet_access  
#set_telnet_port
```

#set_telnet_port

Sets the Telnet listening port on the matrix.

Syntax

```
#set_telnet_port port
```

Parameters

port

Type: **INTEGER**

The desired remote Telnet listening port (0 - 65535) of the matrix.

Example

```
#set_telnet_port 23  
TELNET_PORT 23
```

Related Commands

```
#get_telnet_access  
#get_telnet_port  
#get_telnet_message  
#set_telnet_access  
#set_telnet_message
```

#set_udp_access

Enables or disables UDP access.

Syntax

```
#set_udp_access state
```

Parameters

state

Type: **INTEGER**

Accepts a number, from table below, corresponding to the desired state.

state	Description
0	Disable UDP access
1	Enable UDP access

Example

```
#set_udp_access 0  
UDP_ACCESS 0
```

Related Commands

```
#get_remote_udp_access  
#get_remote_udp_ip  
#get_remote_udp_port  
#get_udp_access  
#get_udp_port  
#set_remote_udp_access  
#set_remote_udp_ip  
#set_remote_udp_port  
#set_udp_port
```

#set_udp_port

Sets the local UDP listening port.

Syntax

```
#set_udp_port port
```

Parameters

port

Type: **INTEGER**

The desired UDP listening port (0 - 65535) of the matrix.

Example

```
#set_udp_port 50007
UDP_PORT 50007
```

Related Commands

```
#get_remote_udp_access
#get_remote_udp_ip
#get_remote_udp_port
#get_udp_access
#get_udp_port
#set_remote_udp_access
#set_remote_udp_ip
#set_remote_udp_port
#set_udp_access
```

#set_vol

Sets the analog output volume level for the specified output(s).

Syntax

```
#set_vol output level
```

Parameters

output

Type: **CHAR / INTEGER**

The alphabetic identifier of the output (A - H). Set this parameter to 0 to set all outputs to the same volume level. Feedback lists all volume levels for outputs in order A - H.

level

Type: **INTEGER**

The desired volume level (0 - 100).

Example

```
#set_vol a 100  
VOL A 100
```

Related Commands

```
#get_vol
```

#set_web_port

Sets the HTTP listening port for the matrix.

Syntax

```
#set_gateway port
```

Parameters

port

Type: **INTEGER**

The desired HTTP listening port for the matrix.

Example

```
#set_gateway 192.168.1.1  
GATEWAY 192.168.1.1
```

Related Commands

```
#get_gateway  
#get_web_port  
#get_ip_address  
#get_ip_mode  
#get_ipconfig  
#get_mac_addr  
#get_netmask  
#set_gateway  
#set_ip_address  
#set_ip_mode  
#set_netmask
```

P

Recalls the specified routing preset.

Syntax

```
p preset
```

Parameters

```
preset
```

Type: **INTEGER**

The number of a preset (1 - 16).

Example

```
p 10  
P 10
```

Related Commands

```
r
```

r

Routes the specified input to the one or more specified outputs.

Syntax

```
r input output [...output]
```

Parameters

input

Type: **INTEGER / CHAR**

The number of an HDMI input (1 - 8). This parameter also accepts a character argument of "X". The "X" argument is not case-sensitive. If "X" is specified, then no input is selected. To "turn on" an input that is marked as "X", use an HDMI input (1 - 8) as the argument.

output

Type: **CHARACTER**

The identifier or an HDMI output (A - H). More than one output may be specified. Set this parameter to 0 to route the `input` to all outputs.

Examples

```
R 1 A
R A 1
```

```
R X A
R A X
```

```
R 1 A B C
R A 1 B 1 C 1
```

```
R 1 0
R A 1 B 1 C 1 D 1 E 1 F 1 G 1 H 1
```

Related Commands

[p](#)

S

Returns the routing state for all inputs / outputs. "X" will be displayed when the output is selected to input off.

Syntax

s

Parameters

None

Example

```
s
S A 1 B 2 C 3 D X E 0 F X G 1 H 0
```

Related Commands

r

This page left intentionally blank.

600 MHz
4K ULTRA 

8x8 Matrix

w/HDR and Audio De-Embedder

4 **Appendix**

Front of RJ-45 Connector

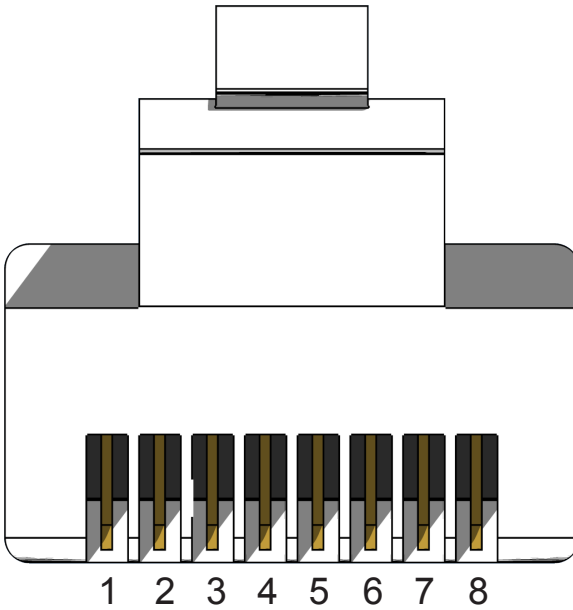

Gefen recommends the TIA/EIA-568-B wiring option. Use the table below when field-terminating cable for use with Gefen products.

Pin	Color	Description
1	Orange / White	TD+ (Transmit Data, positive differential signal)
2	Orange	TD- (Transmit Data, negative differential signal)
3	Green / White	RD+ (Receive Data, positive differential signal)
4	Blue	Unused
5	Blue / White	Unused
6	Green	RD- (Receive Data, negative differential signal)
7	Brown / White	Unused
8	Brown / White	Unused



Information

Shielded CAT-5e (or better) cabling is recommended.

Description	Setting
MAC Address	Device-dependent (cannot be modified)
IP Address	192.168.1.72
Subnet Mask	255.255.255.0
Default Gateway	192.168.1.1
HTTP Listening Port	80
Telnet Listening Port	23
Telnet / TCP Access	Enabled
UDP Port	50007
Enable UDP Access	Disabled
Remote UDP IP Address	192.168.1.255
Remote UDP Port	50008
Remote UDP Access	Disabled
Default Administrator Password	Admin
Default Operator Password	Operator
Gefen Syner-G Discovery	Enabled
Gefen Syner-G Discovery Mode	Read / Write
Gefen Syner-G Show Device	Hide Me

Description	Setting
Output Names	Output A - Output H
A/V Input Names	Input 01 - Input 08
HDCP (each input)	Version 2.2 and below
HDCP (each output)	Follow Input
EDID (each input)	Internal UHD 4K 600Mhz 2Ch
RS-232 Feedback	On
LED Brightness	50
IR Channel	1
Routing	Input 01 > Output A Input 02 > Output B Input 03 > Output C Input 04 > Output D Input 05 > Output E Input 06 > Output F Input 07 > Output G Input 08 > Output H
Preset Names	Preset01 - Preset16
Matrix Lock	Disabled

720p 2-channel audio

Video data block

```
1280x720p @ 60Hz (16:9)
1280x720p @ 50Hz (16:9)
640x480p @ 60Hz (4:3)
720x480p @ 60Hz (16:9)
720x480p @ 60Hz (4:3)
1440x480p @ 60Hz (4:3)
1440x480p @ 60Hz (16:9)
720x576p @ 50Hz (4:3)
1440x480i @ 60Hz (4:3)
1440x480i @ 60Hz (16:9)
720x576p @ 50Hz (16:9)
1440x576i @ 50Hz (4:3)
1440x576i @ 50Hz (16:9)
1440x576p @ 50Hz (4:3)
1440x576p @ 50Hz (16:9)
```

Audio data block

Linear PCM

Max channels: 2

Supported sample rates (kHz): 48 44.1 32

Supported sample sized (bits): 24 20 16

720p Multichannel audio

Video data block

```
640x480p @ 60Hz (4:3)
720x480p @ 60Hz (4:3)
720x480p @ 60Hz (4:3)
1280x720p @ 60Hz (native)
1440x480i @ 60Hz (4:3)
720x576p @ 50Hz (4:3)
720x576p @ 50Hz (16:9)
1280x720p @ 50Hz (16:9)
1440x576i @ 50Hz (4:3)
```

Audio data block

Linear PCM

Max channels: 2

Supported sample rates (kHz): 48 44.1 32

Supported sample sized (bits): 24 20 16

1080p 2-channel audio

Video data block

```
640x480p @ 60Hz (4:3)
720x480p @ 60Hz (16:9)
720x480p @ 60Hz (16:9)
1280x720p @ 60Hz (16:9)
1920x1080i @ 60Hz (16:9)
1440x480i @ 60Hz (4:3)
1440x480i @ 60Hz (16:9)
1440x480p @ 60Hz (4:3)
1440x480p @ 60Hz (16:9)
720x576p @ 50Hz (4:3)
720x576p @ 50Hz (16:9)
1280x720p @ 50Hz (16:9)
1920x1080i @ 50Hz (16:9)
1440x576i @ 50Hz (4:3)
1440x576i @ 50Hz (16:9)
1440x576p @ 50Hz (4:3)
1440x576p @ 50Hz (16:9)
1920x1080p @ 50Hz (16:9)
1920x1080p @ 24Hz (16:9)
1920x1080p @ 25Hz (16:9)
1920x1080p @ 30Hz (16:9)
1920x1080i @ 50Hz (16:9)
1280x720p @ 24Hz (16:9)
1280x720p @ 25Hz (16:9)
1280x720p @ 30Hz (16:9)
1920x1080p @ 60Hz (16:9)
```

Audio data block

Linear PCM

Max channels: 2

Supported sample rates (kHz): 48 44.1 32

Supported sample sized (bits): 24 20 16

1080p Multichannel audio

Video data block

```

640x480p @ 60Hz (4:3)
720x480p @ 60Hz (16:9)
720x480p @ 60Hz (16:9)
1280x720p @ 60Hz (16:9)
1920x1080i @ 60Hz (16:9)
1440x480i @ 60Hz (4:3)
1440x480i @ 60Hz (16:9)
1440x480p @ 60Hz (4:3)
1440x480p @ 60Hz (16:9)
720x576p @ 50Hz (4:3)
720x576p @ 50Hz (16:9)
1280x720p @ 50Hz (16:9)
1920x1080i @ 50Hz (16:9)
1440x576i @ 50Hz (4:3)
1440x576i @ 50Hz (16:9)
1440x576p @ 50Hz (4:3)
1440x576p @ 50Hz (16:9)
1920x1080p @ 50Hz (16:9)
1920x1080p @ 24Hz (16:9)
1920x1080p @ 25Hz (16:9)
1920x1080p @ 30Hz (16:9)
1920x1080i @ 50Hz (16:9)
1280x720p @ 24Hz (16:9)
1280x720p @ 25Hz (16:9)
1280x720p @ 30Hz (16:9)
1920x1080p @ 60Hz (16:9)

```

Audio data block

Linear PCM

Max channels: 2

Supported sample rates (kHz): 192 176.4 96 88.2 48 44.1 32

Supported sample sizes (bits): 24 20 16

Linear PCM

Max channels: 8

Supported sample rates (kHz): 48 44.1 32

Supported sample sizes (bits): 24 20 16

DTS

Max channels: 6

Supported sample rates (kHz): 48 44.1

Maximum bit rate: 0 kHz

AC-3

Max channels: 6

Supported sample rates (kHz): 48 44.1 32

Maximum bit rate: 640 kHz

Enhanced AC-3

Max channels: 8

Supported sample rates (kHz): 48 44.1

4K 2-channel audio

Video data block

```
720x480p @ 60Hz
1280x720p @ 60Hz (16:9)
1920x1080i @ 60Hz (16:9)
1440x480i @ 60Hz (16:9)
1920x1080p @ 60Hz (16:9)
720x576p @ 50Hz (16:9)
1280x720p @ 50Hz (16:9)
1920x1080i @ 50Hz (16:9)
1440x576i @ 50Hz (16:9)
1920x1080p @ 50Hz (16:9)
1920x1080p @ 24Hz (16:9)
1920x1080p @ 25Hz (16:9)
1920x1080p @ 30Hz (16:9)
3840x2160p @ 24Hz (16:9)
3840x2160p @ 25Hz (16:9)
3840x2160p @ 30Hz (16:9)
3840x2160p @ 50Hz (16:9)
3840x2160p @ 60Hz (16:9)
4096x2160p @ 24Hz (256:135)
4096x2160p @ 25Hz (256:135)
4096x2160p @ 30Hz (256:135)
4096x2160p @ 50Hz (256:135)
4096x2160p @ 60Hz (256:135)
```

Audio data block

Linear PCM

```
Max channels: 2
```

```
Supported sample rates (kHz): 192 176.4 96 88.2 48 44.1 32
```

```
Supported sample sizes (bits): 24 20 16
```

4K multichannel audio

Video data block

```

720x480p @ 60Hz
1280x720p @ 60Hz (16:9)
1920x1080i @ 60Hz (16:9)
1440x480i @ 60Hz (16:9)
1920x1080p @ 60Hz (16:9)
720x576p @ 50Hz (16:9)
1280x720p @ 50Hz (16:9)
1920x1080i @ 50Hz (16:9)
1440x576i @ 50Hz (16:9)
1920x1080p @ 50Hz (16:9)
1920x1080p @ 24Hz (16:9)
1920x1080p @ 25Hz (16:9)
1920x1080p @ 30Hz (16:9)
3840x2160p @ 24Hz (16:9)
3840x2160p @ 25Hz (16:9)
3840x2160p @ 30Hz (16:9)
3840x2160p @ 50Hz (16:9)
3840x2160p @ 60Hz (16:9)
4096x2160p @ 24Hz (256:135)
4096x2160p @ 25Hz (256:135)
4096x2160p @ 30Hz (256:135)
4096x2160p @ 50Hz (256:135)
4096x2160p @ 60Hz (256:135)

```

Audio data block

Linear PCM

Max channels: 2

Supported sample rates (kHz): 48 44.1 32

Supported sample sizes (bits): 24 20 16

Linear PCM

Max channels: 8

Supported sample rates (kHz): 96 48 44.1

Supported sample sizes (bits): 24 20 16

AC-3

Max channels: 6

Supported sample rates (kHz): 48

Maximum bit rate: 640 kHz

Enhanced AC-3

Max channels: 8

Supported sample rates (kHz): 192 96 48 44.1

MAT (MLP)

Max channels: 1

Supported sample rates (kHz): 192 96 48 44.1

DTS

Max channels: 6

Supported sample rates (kHz): 96 48 44.1

Maximum bit rate: 1536 kHz

DTS-HD

Max channels: 8

Supported sample rates (kHz): 192 96 48

Supported Formats

Resolutions (max.)	<ul style="list-style-type: none"> • 4096 x 2160 at 60 Hz (4:4:4) • 3860 x 2160 at 60 Hz (4:4:4) • 1080p Full HD • 1920 x 1200 (WUXGA) at 60 Hz
--------------------	---

Connectors, Controls, and Indicators

HDMI Input Connectors	<ul style="list-style-type: none"> • 8 x Type A 19-pin female, locking
HDMI Output Connectors	<ul style="list-style-type: none"> • 8 x Type A 19-pin female, locking
Digital Audio Output Connectors	<ul style="list-style-type: none"> • 8 x TOSLINK® Optical • 8 x RCA Coaxial
Analog L/R Audio Output Connectors	<ul style="list-style-type: none"> • 8 x 3.5mm mini-stereo jack
RS-232 serial port	<ul style="list-style-type: none"> • 1 x DB-9, female
Ethernet (IP Control)	<ul style="list-style-type: none"> • 1 x RJ-45
Front-panel display	<ul style="list-style-type: none"> • 1 x OLED (2x rows, 20 chars / row)
Power Button / Indicator	<ul style="list-style-type: none"> • 1 x Tact-type, bi-color blue/orange backlight
Control Buttons / Indicators	<ul style="list-style-type: none"> • 9 x Tact-type
Reset Button	<ul style="list-style-type: none"> • 1 x Tact-type, recessed
IR Sensor	<ul style="list-style-type: none"> • 1 x located on front panel
IR In/Ext Port	<ul style="list-style-type: none"> • 1 x 3.5mm mini-stereo jack
IR Extender type	<ul style="list-style-type: none"> • EXT-RMT-EXTIRN
DC Power Connector	<ul style="list-style-type: none"> • 1 x 4-pin, locking
Power Supply	<ul style="list-style-type: none"> • 24V DC

Operational

Maximum TMDS Clock	<ul style="list-style-type: none"> • 600 MHz
Total Signal Bandwidth / Data Rate	<ul style="list-style-type: none"> • 18 Gbps
Power Supply	<ul style="list-style-type: none"> • 24V DC
Power Consumption	<ul style="list-style-type: none"> • 45 W
Operating Temperature	<ul style="list-style-type: none"> • +32 to +122 °F (0 to +50 °C)
Operating Humidity	<ul style="list-style-type: none"> • 5% to 90% RH, non-condensing
Storage temperature	<ul style="list-style-type: none"> • -4 to +185 °F (-20 to +85 °C)
Storage humidity	<ul style="list-style-type: none"> • 0% to 95% RH, non-condensing
MTBF	<ul style="list-style-type: none"> • 50000 hours

Physical	
Rack-mount requirements	<ul style="list-style-type: none">Standard 19" rack, 2U high
Dimensions (excluding rack ears and connectors, W x H x D)	<ul style="list-style-type: none">17.25" x 3.5" x 15.75" (440mm x 89mm x 400mm)
Net Unit Weight	<ul style="list-style-type: none">21 lbs (9.5 kg)
Shipping Weight	<ul style="list-style-type: none">29 lbs (13.25 kg)

Features and specifications are subject to change without notice.

All trademarks and registered trademarks are the property of their respective owners.

Copyright© 2017 Core Brands, LLC.

A

Accessing the Menu System 31

Application diagram 11

Audio

muting / unmuting 23

volume, adjusting 21

C

Commands 114

#factory_reset 118, 119

#get_device_desc 120, 121

#get_discovery 122

#get_discovery_mode 123

#get_edid_lock 124

#get_edid_mode 125

#get_gateway 126, 129

#get_http_port 157

#get_input_hdcp 158, 160, 161, 162

#get_io_name 133

#get_ip_address 134

#get_ipconfig 136

#get_ip_mode 135

#get_ir_channel 137

#get_lcd_brightness 138

#get_mac_addr 139

#get_netmask 142

#get_output_hdcp 144

#get_preset_name 145

#get_remote_udp_access 146

#get_remote_udp_ip 147

#get_remote_udp_port 148

#get_telnet_access 150

#get_telnet_port 153

#get_telnet_welcome 152

#get_udp_access 154

#get_udp_port 155

#help 166

#lock_matrix 167

p 203

r 204

#reboot 168

#send_hpd 170

#set_device_desc 172

#set_discovery 173

#set_discovery_mode 174

#set_edid_copy 175

#set_edid_lock 176

#set_edid_mode 177

#set_feedback 178

#set_gateway 179

#set_http_port 202

#set_input_hdcp 180

#set_io_name 181

#set_ip_address 182

#set_ip_mode 183

#set_ir_channel 184

#set_lcd_brightness 185

#set_netmask 188

#set_output_hdcp 189

#set_preset_name 190

#set_remote_udp_access 191

#set_remote_udp_ip 192

#set_remote_udp_port 193

#set_showme 194

#set_telnet_access 195

#set_telnet_port 198

#set_telnet_welcome 197

#set_udp_access 199

#set_udp_port 200

Connection instructions 10

D

Default Settings 209

Discovery Settings 100

E

EDID

copying EDID data 89

custom EDID 88

downloading EDID data 92

EDID mode 87

getting EDID information 91

internal EDID profiles 210

uploading EDID data 94

F

Features *vii*

Firmware Update 104

Front Panel

description 2

Front Panel Controls

accessing the menu system 31

HPD control 35

IP settings

- gateway 46
- HTTP port 47
- IP address 44
- IP mode 44
- subnet mask 45
- IR channel 62
- LCD brightness 60
- locking the matrix
 - using the IR remote control 28
- routing
 - using the IR remote control 20
- routing presets
 - using the front panel 29
 - using the IR remote control 30
- Telnet settings 48
 - TCP access 49
 - TCP port 50
 - welcome message 51
- UDP settings
 - remote UDP access 54
 - remote UDP address 55
 - UDP access 52
 - UDP listening port 53
- unlocking the front panel
 - using the IR remote control 28

H

- HDCP Control 85
- HPD Control 35, 84

I

- IP Settings
 - gateway 46
 - IP address 44
 - IP mode 44
 - subnet mask 45
- IR Remote Control
 - description 5
 - installing batteries 8
 - setting the IR channel 9

L

- Licensing vi
- Locking the Matrix
 - using the IR remote control 28

M

- Masking
 - outputs 77
- Matrix
 - application diagram 10
 - configuration 12
 - connections 10
- Menu System
 - accessing 31
- Muting
 - audio outputs 23

N

- Network
 - cable diagram 208
 - Discovery settings 100
 - IP settings 95
 - TCP / Telnet settings 96
 - Web login settings 99

O

- Operating Notes v
- Output
 - volume, adjusting 21

P

- Packing List viii
- Panel
 - front 2
 - rear 3
- Password
 - default 97
 - setting 97

R

- Rear Panel
 - description 3
- Routing
 - using the IR remote control 20
- RS-232
 - configuration 113
 - feedback 101

S

- Safety Instructions *ii*
- Selecting Routing Presets
 - using the front panel 29*
- Specifications *215*
- Syner-G
 - configuring the matrix 12*

T

- Table of Contents *ix*
- TCP / Telnet Settings
 - TCP access 49*
 - TCP listening port 50*
 - welcome message 51*
- Technical Support *iv*

U

- UDP
 - configuration 112*
 - remote UDP access 54, 98*
 - remote UDP address 55, 98*
 - UDP listening port 53, 98*
- Unlocking the matrix
 - using the IR remote control 28*
- Unmuting
 - audio outputs 23*

V

- Volume
 - muting / unmuting 23*
 - output, adjusting 21*

W

- Warranty Information *iii*
- Web Interface
 - changing input and output names 82*
 - downloading configuration 102*
 - factory reset 107*
 - HDCP 85*
 - HPD control 84*
 - input and output status 81*
 - introduction 68*
 - buttons 70*
 - logging in 68*
 - tabs and sub-tabs 70*
 - LCD brightness 101*
 - locking the matrix 73*
 - masking outputs 77*
 - rebooting the matrix 108*
 - Restoring configuration 103*
 - routing 75*
 - RS-232 feedback 101*
 - setting the EDID mode 87*
 - custom EDID 88*
 - setting the IR channel 106*
 - updating firmware 104*
 - viewing the routing status 74*



1800 S McDowell Blvd. Petaluma CA 94954
(707) 283-5900 (800) 472-5555

Other ManualsLib Projects



www.manualslib.com



www.manualslib.de



www.manualslib.es



www.manualslib.fr



www.manualslib.nl



www.manualslib.mx



www.manualslib.tech 30+ Languages