

KRAMER



USER MANUAL

MODEL:

DIP-20 Automatic Video Switcher



DIP-20 Automatic Video Switcher Quick Start Guide

This guide helps you install and use your product for the first time. For more detailed information, go to <http://www.kramerav.com/manual/DIP-20> to download the latest manual or scan the QR code on the left.

Step 1: Check what's in the box

- ✓ DIP-20 Automatic Video Switcher
- ✓ 1 Quick start guide
- ✓ ADC-DPM/HF DisplayPort (M) to HDMI (F) adapter cable
- ✓ Power adapter (48V)
- ✓ 4 Rubber feet

Step 2: Install the DIP-20

Mount the device in a rack (using the optional **RK-T2B** rack adapter available for purchase) or attach the rubber feet and place the device on a shelf.

Step 3: Connect inputs and outputs

Always switch off the power to all devices before connecting it to your **DIP-20**. For best results, we recommend that you always use Kramer high-performance cables to connect AV equipment to the **DIP-20**.

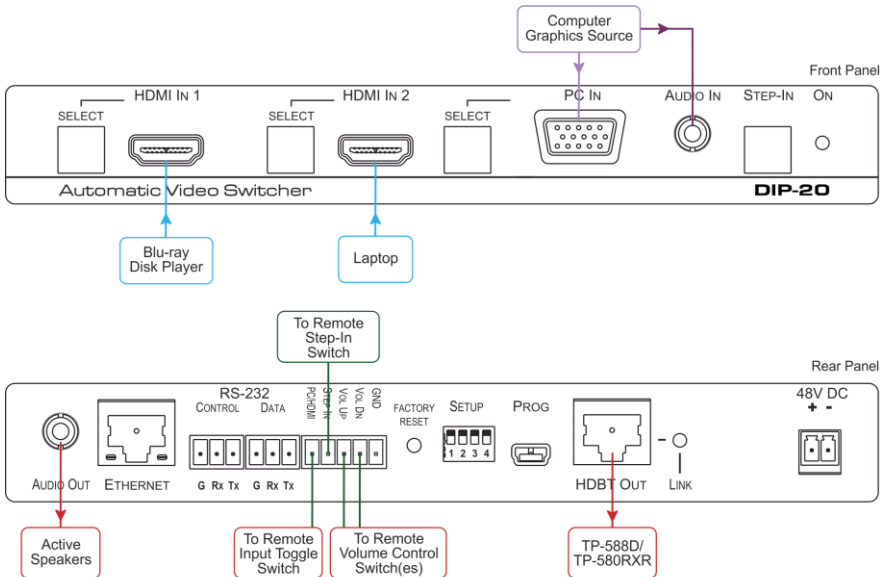

Step 4: Set the DIP-switches

DIP-switch 1	DIP-switch 2	Video Input Selection
Off	Off	Automatic—Last connected. Where more than one source is connected the last one connected has priority
Off	On	Automatic—Priority selection. HDMI 1 → HDMI 2 → PC IN (default, high to low)
On	Off	Manual
On	On	Manual

DIP-switch 3	DIP-switch 4	Audio Input Selection
Off	Off	Automatic—Priority selection. Embedded HDMI → analog Audio In (high to low)
Off	On	Automatic—Priority selection. Analog Audio In → embedded HDMI (high to low)
On	Off	Embedded HDMI
On	On	Analog Audio In

Step 5: Connect the power

Connect the power adapter to the **DIP-20**, and plug the adapter into the mains power. Power on all attached devices.



Step 6: Operate the DIP-20

IP Parameters

Parameter	Values	Default
Device Name	Any alphanumeric string up to 14 chars (can include hyphen, but not at the beginning or end)	KRAMER_
DHCP	ON/OFF	OFF
IP Address	Any valid IP address	192.168.1.39
Mask	Any valid network mask	255.255.0.0
Gateway	Any valid gateway address	192.168.0.1
TCP Port	0 to 65535	5000
UDP Port	0 to 65535	50000

Default Logon Authentication

Parameter	Values
Name	Admin
Password	Admin

To operate the DIP-20:

- ◆ Press the Step-In button to activate the input.
 - ◆ Press the required Select button to switch to that input.
-

Contents

1	Introduction	1
2	Getting Started	2
2.1	Achieving the Best Performance	2
2.2	Safety Instructions	2
2.3	Shielded Twisted Pair/Unshielded Twisted Pair	3
2.4	Recycling Kramer Products	3
3	Overview	4
3.1	About HDBaseT™ Technology	5
4	Defining the Automatic Video Switcher	6
5	Connecting the DIP-20 Automatic Video Switcher	8
5.1	Connecting the Remote Control Switches	10
5.2	Wiring the RJ-45 Connectors	11
6	Principles of Operation	12
6.1	Input Selection	12
6.2	Signal Loss and Unplugged Cable Timeouts	13
6.3	Audio Signal Control	13
6.4	VGA Phase Shift	14
7	Operating the DIP-20	15
7.1	Locking the EDID	15
7.2	Resetting the DIP-20	15
7.3	Analog Audio Output Volume Control	15
8	Configuring the DIP-20	17
8.1	Setting the Configuration DIP-switch	17
8.2	Video Switching Timeouts	18
8.3	Using the Step-in Feature	18
9	Operating the DIP-20 Remotely Using the Web Pages	19
9.1	Browsing the DIP-20 Web Pages	19
9.2	The Switching Page	23
9.3	The Device Settings Page	24
9.4	The Video and Audio Settings Page	27
9.5	The Authentication Page	28
9.6	The EDID Page	29
9.7	The About Us Page	31
10	Technical Specifications	32
10.1	Default IP Parameters	33
10.2	Default Logon Credentials	33
10.3	Supported Resolutions	33
11	Default EDID	35
11.1	HDMI	35
11.2	PC-UXGA	37
12	Protocol 3000	39
12.1	Kramer Protocol 3000 Syntax	39

Figures

Figure 1: DIP-20 Front Panel	6
Figure 2: DIP-20 Rear Panel	7
Figure 3: Connecting the DIP-20	8
Figure 4: Remote Switches Terminal Block	10
Figure 5: TP PINOUT	11
Figure 6: The Configuration DIP-switch	17
Figure 7: Entering Logon Credentials	19
Figure 8: The Default Page	20
Figure 9: The Main Switching Page	21
Figure 10: The Switching Page	23
Figure 11: The Device Settings Page	25
Figure 12: The Video and Audio Settings Page	27
Figure 13: The Authentication Page	28
Figure 14: The EDID Page	29
Figure 15: The About Us Page	31

1 Introduction

Welcome to Kramer Electronics! Since 1981, Kramer Electronics has been providing a world of unique, creative, and affordable solutions to the vast range of problems that confront video, audio, presentation, and broadcasting professionals on a daily basis. In recent years, we have redesigned and upgraded most of our line, making the best even better!

Our 1,000-plus different models now appear in 14 groups that are clearly defined by function: GROUP 1: Distribution Amplifiers; GROUP 2: Switchers and Routers; GROUP 3: Control Systems; GROUP 4: Format/Standards Converters; GROUP 5: Range Extenders and Repeaters; GROUP 6: Specialty AV Products; GROUP 7: Scan Converters and Scalers; GROUP 8: Cables and Connectors; GROUP 9: Room Connectivity; GROUP 10: Accessories and Rack Adapters; GROUP 11: Sierra Video Products; GROUP 12: Digital Signage; GROUP 13: Audio; and GROUP 14: Collaboration.

Congratulations on purchasing your Kramer **DIP-20 Automatic Video Switcher** which are part of the Kramer Audio Distribution System and are ideal for:

- Display systems requiring simple, automatic input selection
- Multimedia and presentation source selection
- Video distribution in hotel rooms and schools

2 Getting Started

We recommend that you:

- Unpack the equipment carefully and save the original box and packaging materials for possible future shipment
- Review the contents of this user manual



Go to <http://www.kramerav.com/downloads/DIP-20> to check for up-to-date user manuals, application programs, and to check if firmware upgrades are available (where appropriate).

2.1 Achieving the Best Performance

To achieve the best performance:

- Use only good quality connection cables (we recommend Kramer high-performance, high-resolution cables) to avoid interference, deterioration in signal quality due to poor matching, and elevated noise levels (often associated with low quality cables)
- Do not secure the cables in tight bundles or roll the slack into tight coils
- Avoid interference from neighboring electrical appliances that may adversely influence signal quality
- Position your **DIP-20 Automatic Video Switcher** away from moisture, excessive sunlight and dust



This equipment is to be used only inside a building. It may only be connected to other equipment that is installed inside a building.

2.2 Safety Instructions



Caution: There are no operator serviceable parts inside the unit

Warning: Use only the power cord that is supplied with the unit

Warning: Do not open the unit. High voltages can cause electrical shock! Servicing by qualified personnel only

Warning: Disconnect the power and unplug the unit from the wall before installing

2.3 Shielded Twisted Pair/Unshielded Twisted Pair

Kramer engineers have developed special twisted pair cables to best match our digital twisted pair products; the Kramer **BC-HDKat6a** (CAT 6 23 AWG) HDBaseT certified, and the Kramer **BC-DGKat7a23** (CAT 7a 23 AWG) cables. These specially built cables significantly outperform regular CAT 6 and CAT 7a cables.

2.4 Recycling Kramer Products

The Waste Electrical and Electronic Equipment (WEEE) Directive 2002/96/EC aims to reduce the amount of WEEE sent for disposal to landfill or incineration by requiring it to be collected and recycled. To comply with the WEEE Directive, Kramer Electronics has made arrangements with the European Advanced Recycling Network (EARN) and will cover any costs of treatment, recycling and recovery of waste Kramer Electronics branded equipment on arrival at the EARN facility. For details of Kramer's recycling arrangements in your particular country go to our recycling pages at <http://www.kramerelectronics.com/support/recycling/>.

3 Overview

The **DIP-20** accepts an HDMI and PC graphics video input, an Ethernet signal, serial data, and an unbalanced stereo audio input (which is embedded into the output signal), and transmits the signal via HDBaseT (Twisted Pair) cable to a compatible receiver (for example, the **TP-588D** or the **TP-580RXR**). The **DIP-20** is a PoE (Power over Ethernet) provider and can power compatible PoE acceptors, (for example, the **TP-588D** and the **TP-590RXR**).

The **DIP-20** provides a range of up to 130m (427ft) in normal mode for 1080p@60Hz @36bpp, and 100m (328ft) for 4K @30Hz. When using an extended range receiver and **BC-HDKat6a** cables, the range is up to 180m (590ft) for 1080p@60Hz @24bpp. To use the **DIP-20** in extended range mode you must edit the EDID.



For optimum range and performance, use Kramer's **BC-HDKat6a** and **BC-DGKat7a23** shielded twisted pair (STP) cables. Note that the transmission range depends on the signal resolution, graphics card and display used. The distance using non-Kramer CAT 6 and CAT 7 cables may not reach these ranges.

The **DIP-20 Automatic Video Switcher** features:

- Support for 4K UHD (data rate of up to 10.2Gbps)
- Automatic live input detection based on video clock presence
- Automatic input selection based on priority selection or last connected input
- Manual input selection
- Automatic analog audio detection and embedding
- Power over Ethernet which passes electrical power along with data over Ethernet cabling. This allows a single cable to provide both data connection and electrical power to compatible devices
- Control via Kramer Protocol 3000 and embedded Web pages over a LAN
- HDTV support
- HDMI with Deep Color, x.v.Color™ and 3D
- HDCP compliancy—works with sources that support HDCP repeater mode

- I-EDIDPro™ Kramer Intelligent EDID Processing™ – Intelligent EDID handling & processing algorithm ensures Plug and Play operation for HDMI systems
- A lockable EDID
- Step-in control when connected to a device that provides step-in support
- Remote control via contact-closure switches
- Equalization and re-clocking of the data
- Support for digital audio formats

3.1 About HDBaseT™ Technology

HDBaseT™ is an advanced, all-in-one connectivity technology (supported by the HDBaseT Alliance). It is particularly suitable in the ProAV – and also the home – environment as a digital networking alternative, where it enables you to replace numerous cables and connectors by a single LAN cable used to transmit, for example, uncompressed, full high-definition video, audio, IR, as well as various control signals.



The products described in this user manual are HDBaseT certified.

4 Defining the Automatic Video Switcher

Figure 1 defines the front panel of the DIP-20.

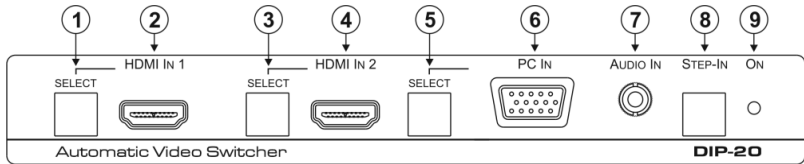

Figure 1: DIP-20 Front Panel

#	Feature	Function
1	<i>HDMI IN 1</i>	SELECT Button Press to select the HDMI 1 input. When HDMI 1 is selected, the button: <ul style="list-style-type: none"> • Lights red when analog Audio In audio is selected • Lights green when embedded audio is selected
2		HDMI 1 Connector Connect to the first HDMI source
3	<i>HDMI IN 2</i>	SELECT Button Press to select the HDMI 2 input. When HDMI 2 is selected, the button: <ul style="list-style-type: none"> • Lights red when analog Audio In audio is selected • Lights green when embedded audio is selected
4		HDMI 2 Connector Connect to the second HDMI source
5	<i>PC IN</i>	SELECT Button Press to select the PC graphics input. When PC graphics is selected, the button: <ul style="list-style-type: none"> • Lights red when analog Audio In audio is selected • Lights green when embedded audio from embedded HDMI is selected, (see Section 8.1)
6		PC Graphics 15-pin HD Connector Connect to the PC graphics source, (for example, a laptop)
7	<i>AUDIO IN</i> 3.5mm Mini Jack	Connect to the unbalanced, stereo audio source, (for example, the audio output of the laptop)
8	<i>Step-In</i> Button	Press to take control of the input that this device is connected to on a compatible switcher
9	<i>ON</i> LED	The LED indicates the following: <ul style="list-style-type: none"> • Lights green—power is provided by a power adapter • Lights red—power is provided via PoE to another device

Figure 2 defines the rear panel of the **DIP-20**.

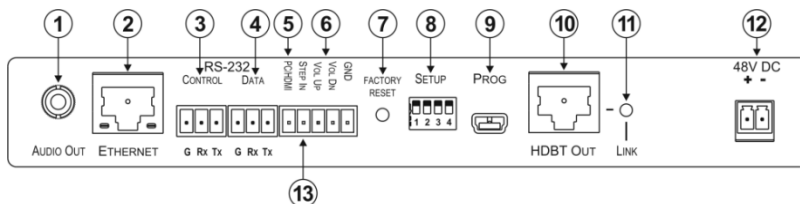

Figure 2: DIP-20 Rear Panel

#	Feature	Function	
1	AUDIO OUT 3.5mm Mini Jack	Connect to the unbalanced, stereo audio acceptor, (for example, active speakers)	
2	ETHERNET RJ-45 Connector	Connect to the LAN, (Ethernet traffic or PC controller)	
3	RS-232	CONTROL 3-pin Terminal Block	Connect to a serial controller or PC
4		DATA 3-pin Terminal Block	Connect to a serial data source or acceptor, (RS-232 data over HDBT)
5	PC/HDMI Remote Toggle Switch Terminal Block	Connect to a remote switch to toggle between the PC graphics and HDMI inputs	
6	Remote Contact-closure 4-pin Terminal Block	Connect to remote momentary switches to control input selection, step-in, and volume up and down	
7	FACTORY RESET Button	Short press to reboot, long press to reset the device to factory default parameters	
8	SETUP 4-way DIP-switch	Switches for setting the device behavior, (see Section 8.1)	
9	PROG Mini USB Connector	Connect to a PC to perform a firmware upgrade	
10	HDBT OUT RJ-45 TP Connector	Connect to a compatible HDBT TP switcher or receiver (for example, the TP-588D/TP-580Rxr)	
11	LINK LED	Lights green when there is a valid HDBT link	
12	48V DC Connector	Connect to the supplied power adapter	
13	STEP IN Remote Toggle Switch Terminal Block	Connect to a remote switch to activate the step in function	

5 Connecting the DIP-20 Automatic Video Switcher



Always switch off the power to each device before connecting it to your **DIP-20**. After connecting your **DIP-20**, connect the power to each of them and then switch on the power to each device.

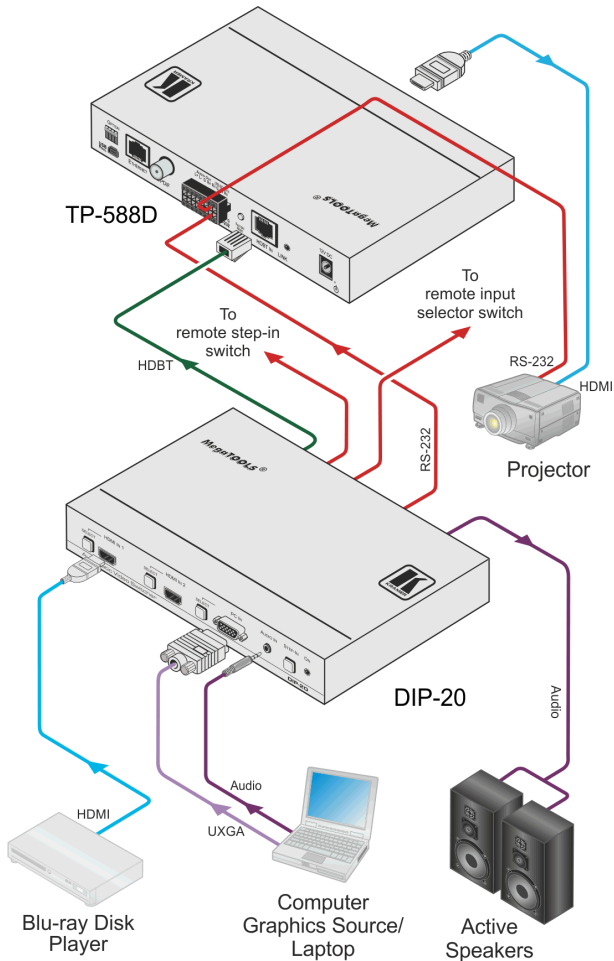

Figure 3: Connecting the DIP-20



You do not have to connect all the inputs and outputs, connect only those that are required.

To connect the DIP-20 as illustrated in [Figure 3](#):

1. Connect an HDMI source, (for example, a Blu-ray disk player) to the HDMI IN 1 input.
2. Connect a PC graphics source, (for example, a laptop) to the PC In input.
3. Connect an unbalanced stereo audio source, (for example, the audio output from the laptop) to the AUDIO IN 3.5mm mini jack.
4. Connect the HDBT OUT RJ-45 connector on the rear panel of the **DIP-20** to an HDBT-compatible receiver (for example, the **TP-588D** or **TP-580Rxr**).
5. Connect the HDMI output of the HDBT acceptor, (for example, the **TP-588D** or **TP-580Rxr**) to the HDMI acceptor, (for example, a projector).
6. Connect the AUDIO OUT 3-pin terminal block on the rear panel of the **DIP-20** to the unbalanced, stereo audio acceptor, (for example, active speakers).
7. Connect the STEP IN 2-way terminal block to a momentary, contact-closure switch, (see [Section 5.1](#)).
8. Connect the PC/HDMI 2-way terminal block to a momentary, contact-closure switch, (see [Section 5.1](#)).
9. Connect the RS-232 DATA 3-pin terminal block to the device to be controlled, (for example, the projector connected in step 5).
10. Connect the power adapter to the **DIP-20** and to the mains power, (not shown in [Figure 3](#)).

5.1 Connecting the Remote Control Switches

You can connect remote, momentary-contact contact-closure switches to the terminal block on the rear panel of the **DIP-20** to control the device.

[Figure 4](#) illustrates the connections from the terminal block to the contact-closure switches.

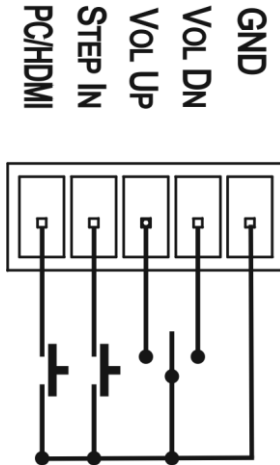

Figure 4: Remote Switches Terminal Block

#	Feature	Function
1	PC/HDMI—input selection/VGA phase shift adjustment	Short press—Input toggle Long press—Adjusts the VGA phase shift, (see Section 6.4)
2	STEP IN	Activates the step-in function if relevant
3	VOL UP—analog audio output volume increase control, (see Section 7.3)	Short press—Increases the volume one step Long press—Increases the volume from 0% to 100% in 10 seconds
4	VOL DN—analog audio output volume decrease control, (see Section 7.3)	Short press—Decreases the volume one step Long press—Decreases the volume from 100% to 0% in 10 seconds
G	GND	Connect to the common side of the switches

5.2 Wiring the RJ-45 Connectors

This section defines the TP pinout, using a straight pin-to-pin cable with RJ-45 connectors.

EIA /TIA 568B	
PIN	Wire Color
1	Orange / White
2	Orange
3	Green / White
4	Blue
5	Blue / White
6	Green
7	Brown / White
8	Brown

Figure 5: TP PINOUT

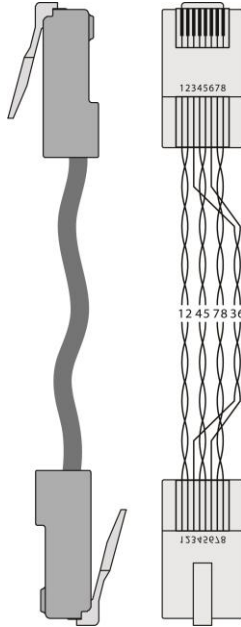

6 Principles of Operation

The **DIP-20** selects video and audio inputs based on the rules described below.

6.1 Input Selection

The video mode selection is set by the DIP-switches (see [Section 8.1](#)) to either of the following modes:

- Manual
- Auto—Last connected or priority mode

In manual mode switching occurs whether or not there is a live signal present on the input. You manually select an input using any of the following methods:

- Front panel buttons
- Remote input selection switches
- RS-232 control
- The Web pages

In auto mode, the switching selection is performed based on either last connected or priority input.

In last connected mode, if the signal on the current input is lost, the **DIP-20** automatically selects the last connected input, (the delay depending on a configurable timeout).

In priority mode, when the input sync signal is lost for any reason, the input with a live signal and next in priority is selected automatically, (the delay depending on the configurable signal-lost timeout). This priority is configurable; the default setting is HDMI 1 → HDMI 2 → PC.

Note: In both last connected and priority modes, manually selecting an input (using the remote input selection switches or any of the above methods) overrides automatic selection.

6.2 Signal Loss and Unplugged Cable Timeouts

In both last connected and priority modes, when the input signal sync is lost (but the cable is not removed) there is a default delay (ten seconds for video, not applicable to the PC input, and five seconds for analog audio) before another input is automatically selected. When an input cable is removed, there is a delay before automatic switching takes place.

Both timeouts are configurable, (see [Section 8.1](#)).

Note: Analog audio is not output when there is no display connected. If a display is connected analog audio is output even in the absence of a video signal.

6.3 Audio Signal Control

The Option DIP-switches 3 and 4 (see [Section 8.1](#)) control the manner in which audio is handled.

The following table describes which audio signal is embedded in the output.

Selected Video Input	HDMI Embedded Audio Detected	Analog Audio In Detected	DIP-switch 3	DIP-switch 4	Audio on HDBT Output
VGA	N/A	Yes	N/A	N/A	Analog Audio In
VGA	N/A	No	N/A	N/A	No audio
HDMI	N/A	N/A	Manual	Embedded	Embedded HDMI audio
HDMI	N/A	N/A	Manual	Analog	Analog Audio In
HDMI	Yes	No	Auto	N/A	Embedded HDMI audio
HDMI	Yes	Yes	Auto	Embedded	Embedded HDMI audio
HDMI	Yes	Yes	Auto	Analog	Analog Audio In
HDMI	No	Yes	Auto	N/A	Analog Audio In
HDMI	No	No	Auto	N/A	No audio

When there is an audio signal but no video signal the output is a black video pattern in conjunction with the external analog Audio In signal.

Note: The default timeout for audio switching when the input signal is lost is five seconds. This can be changed using either P3000 commands or the Web pages.

6.4 VGA Phase Shift

To minimize phase on the input VGA signal, the VGA sampling phase can be shifted using the following methods:

- A long press on the PC IN select button on the front panel.
Each long press steps the phase shift up one step, starting from 0 and going to 31. When set to 31, another long press steps the shift to 0
- A remote, contact-closure switch connected to pins 1 and G of the Remote terminal block.
Each long press steps the phase shift up one step, starting from 0 and going to 31. When set to 31, another long press steps the shift to 0
- Using the Web pages, (see [Section 9.1](#))
- Protocol 3000 commands over RS-232 (see [Section 12](#))

7 Operating the DIP-20

The DIP-20 can be operated using any of the following methods:

- Front panel buttons
- Protocol 3000 command, (see [Section 12](#))
- Remote contact-closure switch, (see [Section 5.1](#))
- Web pages, (see [Section 9](#))

7.1 Locking the EDID

To prevent the stored EDID (either default or read from a device) from being overwritten, either send a Protocol 3000 command or use the Web pages.

7.2 Resetting the DIP-20

To perform a soft reset of the DIP-20:

- Briefly press the Reset button.
The device resets

To reset the DIP-20 to factory default parameters:

- Press and hold the Reset button for five seconds.
The device is reset to factory default parameters

7.3 Analog Audio Output Volume Control

The analog audio output volume can be controlled using the Web pages, (see [Section 9.1](#)) or via the remote, contact-closure switches connected to pins 3 and 4 of the Remote terminal block, (see [Section 5.1](#)).

The up/down volume steps per press are detailed in the table below.

Volume Reading	Volume (dB)
100	0
99	-0.5
98	-1.0
97	-1.5
96	-2.0
...	(0.5dB steps)
12	-44.0
11	-44.5
10	-45.0
9	-45.5
...	(2.0dB steps)
8	-47.0
7	-49.0
6	-51.0
5	-53.0
4	-55.0
3	-57.0
2	-59.0
1	-61.0
0	-63.0

8 Configuring the DIP-20

8.1 Setting the Configuration DIP-switch

The 4-way dip-switch provides the ability to configure a number of device functions. A switch that is down is on; a switch that is up is off. By default, all the switches are up (off).

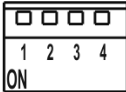

Figure 6: The Configuration DIP-switch

Note: After changing a dip-switch you must power cycle the device to implement the change.

Video Switching Selection

DIP-switch 1	DIP-switch 2	Video Input Selection
Off	Off	Automatic—Last connected. Where more than one source is connected the last one connected has priority
Off	On	Automatic—Priority selection. HDMI 1 → HDMI 2 → PC IN (default, high to low)
On	Off	Manual
On	On	Manual

Audio Switching Selection

DIP-switch 3	DIP-switch 4	Audio Input Selection
Off	Off	Automatic—Priority selection. Embedded HDMI → analog Audio In (high to low)
Off	On	Automatic—Priority selection. Analog Audio In → embedded HDMI (high to low)
On	Off	Embedded HDMI
On	On	Analog Audio In

8.2 Video Switching Timeouts

When the **DIP-20** is configured for auto switching, the timeouts before a new input is automatically selected can be changed as shown in the table below.

	Signal Loss, Power Present	Signal and Power Loss
Default Timeout	10 seconds	0 seconds

Note: The minimum value of “Signal Loss, Power Present” is five seconds.

8.3 Using the Step-in Feature

To be able to use the Step-in feature, you need to assign the RS-232 signal that is transmitted over the HDBT link to control, (see [Section 9.2](#)). The Step-in button on the front panel will now operate in conjunction with a compatible receiver, for example, the **VS-62H**).

9 Operating the DIP-20 Remotely Using the Web Pages

The **DIP-20** can be operated remotely using the embedded Web pages. The Web pages are accessed using a Web browser and an Ethernet connection.

Before attempting to connect:

- Ensure that your browser is supported (see [Section 10.1](#))
- Ensure that JavaScript is enabled

9.1 Browsing the DIP-20 Web Pages

Note: In the event that a Web page does not update correctly, clear your Web browser's cache by pressing CTRL+F5.

To browse the DIP-20 Web pages:

1. Open your Internet browser.
2. Type the IP number of the device (see [Section 10.1](#)) in the Address bar of your browser.



Note: If authentication is enabled, the following window appears ([Figure 7](#)) and you must enter the valid username and password to access the Web pages.

For default authentication details, see [Section 10.2](#).

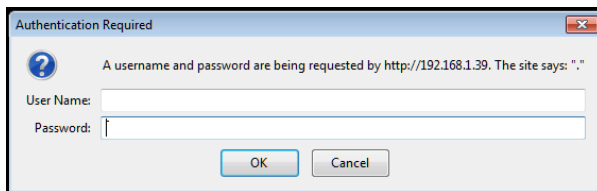

Figure 7: Entering Logon Credentials

Following a successful logon, the screen shown in [Figure 8](#) is displayed.

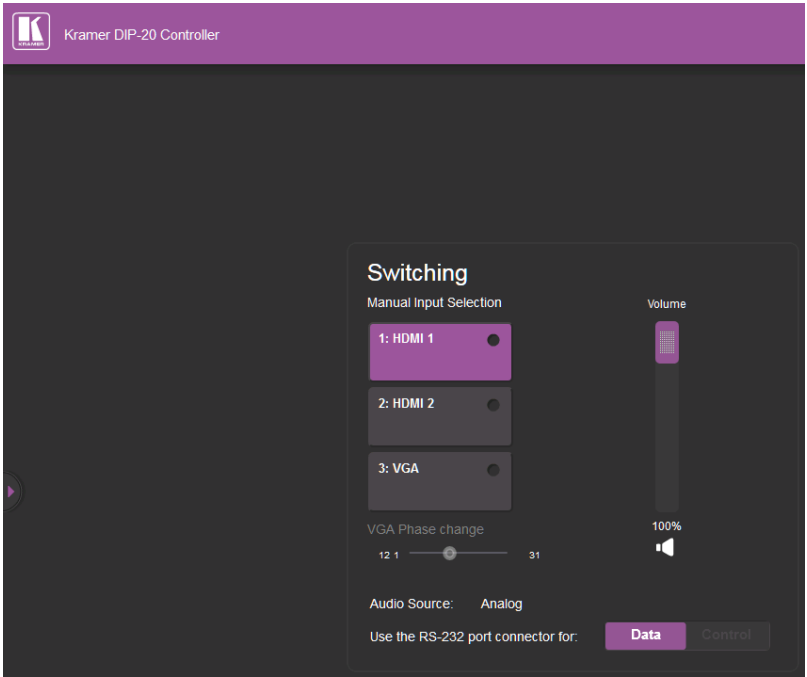

Figure 8: The Default Page

Click the Reveal button to open the left hand side page panel.

The Switching page appears as shown in [Figure 9](#).

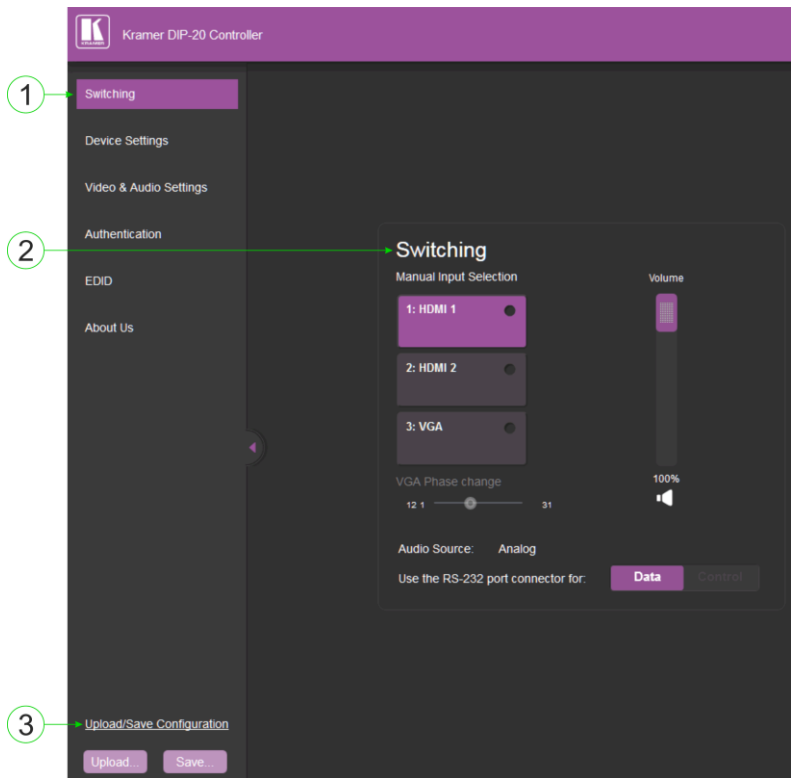

Figure 9: The Main Switching Page

The areas of the main switching page are described in the following table.

#	Item	Description
1	Page Selection Panel	Click one of the buttons to select a page
2	Switching Selection	Switching and control section. Click one of the buttons to select a video input. Adjust the VGA phase shift. Adjust the audio volume. Select data routing mode
3	Upload/Save Configuration Area	Click one of the buttons to save or retrieve a configuration, (see Section 9.1.1)

There are six Web pages described in the following sections:

- Switching (see [Section 9.2](#))
- Device Settings (see [Section 9.3](#))
- Video and Audio Settings (see [Section 9.4](#))
- Authentication (see [Section 9.5](#))
- EDID (see [Section 9.6](#))
- About Us (see [Section 9.7](#))

9.1.1 The Upload/Save Configuration Facility

The Upload/Save Configuration facility (see item 4 in [Figure 9](#)) lets you retrieve and save a configuration.

To upload a configuration:

1. Click the Upload button.
The File Upload browser window appears.
2. Browse to the required file and press Open.
The configuration is retrieved and the success message is displayed.

To save the current configuration:

1. Click the Save button.
The Save Configuration success message is displayed.
2. Do either of the following:
 - Click Download to either open the file or save it to the required location
—OR—
 - Click OK to complete the procedure

9.2 The Switching Page

The Switching page lets you select a video input manually and adjust the audio volume.

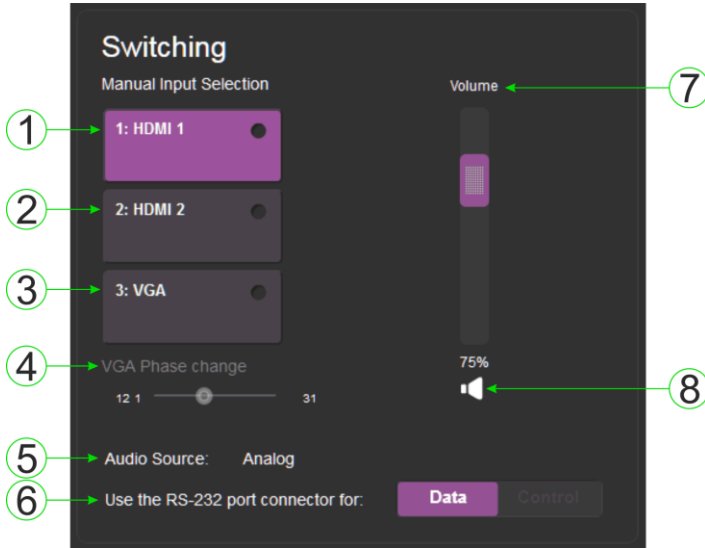

Figure 10: The Switching Page

#	Item	Description
1	<i>HDMI 1</i> Button	Click to select the HDMI 1 input. The button color indicates whether or not there is a live signal on the input
2	<i>HDMI 2</i> Button	Click to select the HDMI 2 input
3	<i>VGA</i> Button	Click to select the VGA input
4	<i>VGA Phase Change</i> Slider	Click and slide to the left or right to adjust the VGA phase change
5	<i>Audio Source:</i> Indicator	Indicates the source of the audio that is transmitted on the output
6	<i>Use the RS-232 port connector for:</i> Button	Assigns the use of the RS-232 signal over HDBT to either data or control: <ul style="list-style-type: none"> <i>Data</i> for passive mode to route RS-232 traffic transparently <i>Control</i> for active mode to route RS-232 commands to the microprocessor to control the DIP-20, (mandatory when the step-in function is required)
7	<i>Volume</i> Slider	Click and slide up and down to increase or decrease the audio output volume
8	Mute Button	Click to mute or unmute the output audio

Note: To be able to use the Step-in feature, you need to assign the RS-232 signal that is transmitted over the HDBT link to control. The Step-in button on the front panel will now operate in conjunction with a compatible receiver, for example, the **VS-62H**).

9.3 The Device Settings Page

The Device Settings page lets you:

- View some of the device characteristics, (for example, model and Web version)
- Edit IP settings, (for example, name and IP address)
- Upgrade the firmware
- Reset the device to factory default settings

Note: After making any change to the parameters on the Device Settings page, you must power cycle the device to activate the changes.



Figure 11: The Device Settings Page

#	Item	Description
1	Information Section	Displays information regarding the device, such as, the model, serial number, and MAC address
2	DNS name	The DNS name of the device. To set a new name, enter the new alphanumeric name and click Set. (For restrictions regarding the name, see Section 10.2)
3	DHCP Buttons	Click ON to turn DHCP on; click OFF to turn DHCP off and use static IP addressing
4	IP address	The IP address of the device. To set a new IP address, enter the new valid IP address and click Set
5	Mask	The network mask of the device. To set a new mask, enter the new valid mask and click Set
6	Gateway	The network gateway for the device. To set a new network gateway, enter the new valid gateway and click Set
7	TCP Port	The TCP port number of the device. To set a new TCP port number, enter the new valid port number or use the spin controls and click Set
8	UDP Port	The UDP port number of the device. To set a new UDP port number, enter the new valid port number or use the spin controls and click Set

#	Item	Description
9	Firmware upgrade Section	BROWSE button Click to open a window to browse to the new firmware file
10		START UPGRADE button Click to start the upgrade process following the selection of the new firmware file
11	Factory Reset Button	Click to reset the device to factory default parameters. After the success message is displayed, power cycle the device
12	Set Button	Click to store a changed parameter. Note: If you do not click the Set button, the new parameter is not stored

To upgrade the firmware:

1. Click the Browse button.
The Windows Browser opens.
2. Browse to the required file.
3. Select the required file and click Open.
The firmware file name is displayed in the Firmware Upgrade page.
4. Click Start Upgrade.
The firmware file is loaded and a progress bar is displayed.



Do not interrupt the process or the **DIP-20** may be damaged.

5. When the process is complete reboot the device.
The firmware is upgraded.

To reset the DIP-20 to factory default parameters:

1. Click the Factory reset button.
The confirmation message is displayed.
2. Click OK to continue or Cancel to exit the procedure.
3. Click OK.
The progress message is displayed.
On completion, the success message is displayed.

- Click OK.

9.4 The Video and Audio Settings Page

The Video and Audio Settings page lets you modify the video, audio and timeout parameters.

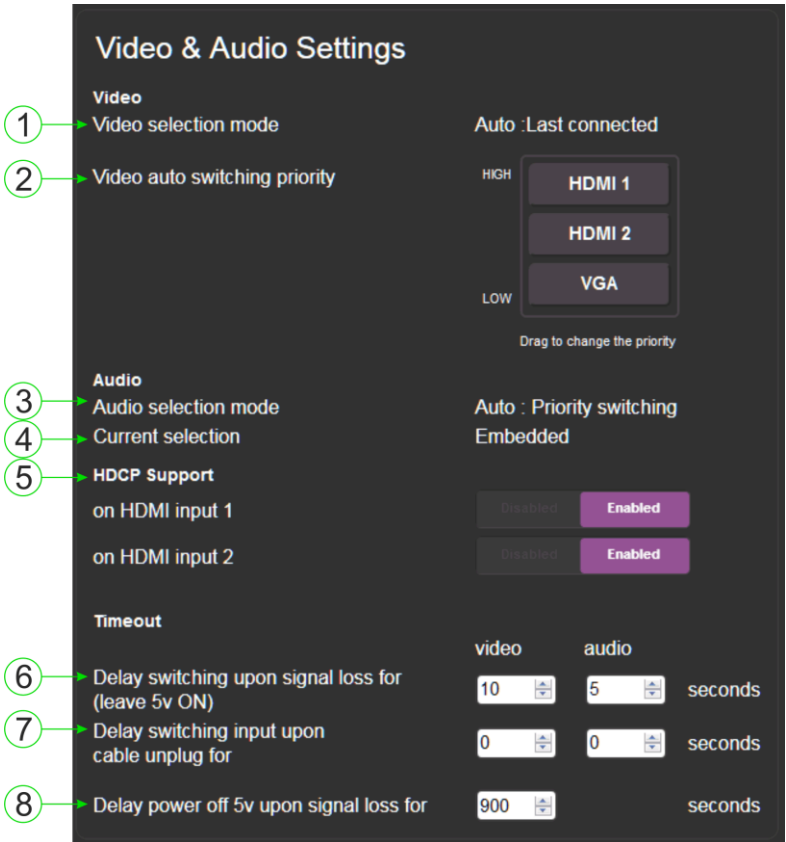

Figure 12: The Video and Audio Settings Page

#	Item	Description
1	Video selection mode Indicator	Indicates the current video selection mode; manual, auto, or auto last connected
2	Video auto switching priority Buttons	Click and drag the buttons to the required priority level to use when in auto mode

#	Item	Description
3	Audio selection mode Indicator	Indicates the current audio selection; manual, auto, or auto last connected
4	Current selection Audio Indicator	Indicates the current audio selection; Embedded or analog
5	HDCP Support (on HDMI input) Buttons	Select HDCP support for HDMI 1 and HDMI 2 Disabled—HDCP encrypted content is not passed Enabled—HDCP support is dictated by the display
6	Delay switching upon signal loss for (leave 5V on) Box	Sets the delay for video and audio before switching (in auto mode) because of a signal loss on the currently selected input. Value in seconds
7	Delay switching input upon cable unplug for Box	Sets the delay for video and audio before switching (in auto mode) because the currently selected input cable is unplugged. Value in seconds
8	Delay power off 5V upon signal loss for Box	Sets the delay for turning off the 5V output because of a signal loss on the currently selected input. Value in minutes

9.5 The Authentication Page

The Authentication page lets you assign or change logon authentication details.

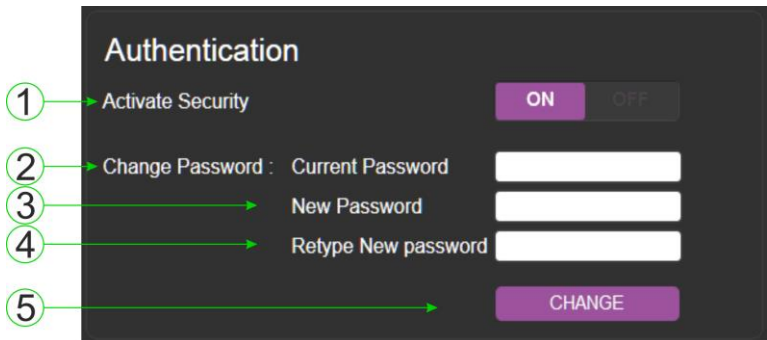

Figure 13: The Authentication Page

#	Item	Description
1	Activate Security Button	Click to enable/disable security settings. When enabled, the valid username and password must be provided to allow Web page access

#	Item	Description	
2	Current Password box	Enter the current password	
3	Change Password	New Password box	Enter the new password, (up to 15 printable ASCII characters)
4		Retype New Password box	Retype the new password
5	CHANGE button	Click CHANGE to save the new authentication details	

9.6 The EDID Page

The EDID page lets you copy EDID data to either or both of the inputs from the following sources:

- Output
- Input
- Default EDID
- EDID data file

From this page you can also lock the EDID on each input independently.

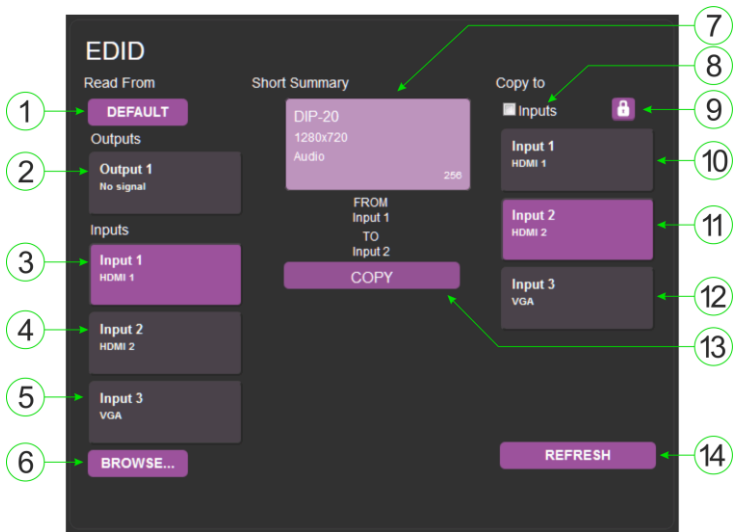

Figure 14: The EDID Page

Note: The display is not updated automatically when the status of an EDID changes on the device caused by outputs being exchanged. Click Refresh to update the display, (see item 11 in the following table).

#	Item	Description
1	<i>Read from Section</i>	<i>DEFAULT EDID</i> button
2		<i>Output 1</i> button
3		<i>Input 1</i> button
4		<i>Input 2</i> button
5		<i>Input 3</i> button
6		<i>BROWSE</i> button
7	<i>Short Summary</i> Information Section	Displays the current election of EDID source, destination, video resolution, audio availability, and status
8	<i>Copy to Section</i>	<i>Inputs</i> selection box
9		Lock button
10		<i>Input 1</i> button
11		<i>Input 2</i> button
12		<i>Input 3</i> button
13	<i>COPY</i> Button	
14	<i>REFRESH</i> Button	

To copy EDID data from a source to one or both inputs:

1. Click the source button from which to read the EDID (default, output, input, or EDID file).
The button changes color and the EDID summary information reflects the selection and EDID data.
2. Click a destination input, or select both inputs by checking the Inputs check-box.
All selected input buttons change color and the EDID summary information reflects the selection and EDID data.
3. Click the Copy button.
The “EDID was copied” success message is displayed and the EDID data is copied to the selected input(s).

4. Click OK.

9.7 The About Us Page

The **DIP-20** About Us page displays the Web page version and Kramer Electronics Ltd company details.



Figure 15: The About Us Page

10 Technical Specifications

INPUTS:	Video:	2 HDMI on HDMI connectors 1 VGA on a 15-pin HD (F) connector
	Audio:	1 Unbalanced stereo audio 1V RMS (nominal) on a 3.5mm mini jack
OUTPUTS:	Video:	1 HDBaseT on an RJ-45 connector
	Audio:	1 Unbalanced stereo audio 1V RMS (nominal) on a 3.5mm mini jack
PORTS:	1 Ethernet on an RJ-45 connector 1 RS-232 3-pin terminal block control port 1 RS-232 3-pin terminal block data port 1 USB on mini USB connector	
CONTROLS:	Remote switches for input switching, step-in, volume control, and device reset switch	
STANDARDS:	HDMI with Deep Color, x.v.Color™ and 3D HDCP—works with sources that support HDCP repeater mode HDBT certified	
MAXIMUM ANALOG AUDIO LEVELS:	3.1V p-p	
THD:	0.013%	
SNR:	75dB	
SUPPORTED WEB BROWSERS:	Windows 7 and higher: <ul style="list-style-type: none"> • Internet Explorer (32/64 bit) version 11 • Firefox version 30 • Chrome version 35 MAC: <ul style="list-style-type: none"> • Chrome version 35 • Firefox version 27 • Safari version 7 Android OS: <ul style="list-style-type: none"> • Chrome version 35 iOS: <ul style="list-style-type: none"> • Chrome version 35 • Safari version 7 	
MAXIMUM TRANSMISSION DISTANCE:	180m (590ft) up to 1080p @60Hz @24bpp in extended mode 130m (430ft) up to 1080p @60Hz @36bpp in normal mode	
POWER CONSUMPTION:	48V DC, 630mA	
OPERATING TEMPERATURE:	0° to +40°C (32° to 104°F)	
STORAGE TEMPERATURE:	-40° to +70°C (-40° to 158°F)	
HUMIDITY:	10% to 90%, RHL non-condensing	
COOLING:	Convection	
ENCLOSURE TYPE:	Aluminium	

DIMENSIONS:	18.75cm x 11.5cm x 2.54cm (7.38" x 4.53" x 1.0") W, D, H
WEIGHT:	0.46kg (1.01lbs) approx.
SHIPPING WEIGHT:	1.16kg (2.56lbs) approx.
ENVIRONMENTAL REGULATORY COMPLIANCE:	Complies with appropriate requirements of RoHs and WEEE
INCLUDED ACCESSORIES:	Power adapter 48V DC 1.36A ADC-DPM/HF DisplayPort (M) to HDMI (F) adapter cable Power cord
OPTIONS:	Rack adapter RK-T2B
WARRANTY:	7 years parts and labor

10.1 Default IP Parameters

Parameter	Values	Default
Device Name	Any alphanumeric string up to 14 chars (can include hyphen, but not at the beginning or end)	KRAMER_
DHCP	ON/OFF	OFF
IP Address	Any valid IP address	192.168.1.39
Mask	Any valid network mask	255.255.0.0
Gateway	Any valid gateway address	192.168.0.1
TCP Port	0 to 65535	5000
UDP Port	0 to 65535	50000

10.2 Default Logon Credentials

Parameter	Values
Name	Admin
Password	Admin

10.3 Supported Resolutions

10.3.1 HDMI

Resolution	Refresh Rate (Hz)
640x480p	85Hz; 75Hz; 72Hz; 60Hz; 59.95Hz
720x480p	60Hz
720x480i	30Hz
720x576p	50Hz
800x600p	85Hz; 75Hz; 72Hz; 60Hz
848x480p	60Hz
852x480p	60Hz

Resolution	Refresh Rate (Hz)
1024x768p	85Hz; 75Hz; 70Hz; 60Hz
1152x864p	75Hz
1280x768p	60Hz
1280x800p	60Hz
1280x960	60Hz
1280x1024p	75Hz; 60Hz
1360x768p	60Hz
1366x768	60Hz; 50Hz
1400x1050p	60Hz
1440x900p	60Hz
1600x900p	60Hz
1600x1200p	60Hz
1680x1050p	60Hz
1920x1080p	50Hz; 60Hz; 30Hz; 24Hz;
1920x1080i	50Hz; 60Hz;
3840x2160	30Hz
4096x2160	30Hz

10.3.2 VGA

Resolution	Refresh Rate
640x480p	60Hz
720x480p	60Hz
800x600p	60Hz
848x480p	60Hz
1024x768p	60Hz
1152x864	75Hz
1280x720p	60Hz; 50Hz
1280x768	60Hz
1280x800	60Hz
1280x960p	60Hz
1280x1024p	60Hz
1360x768	60Hz;
1366x768	60Hz; 50Hz
1400x1050	60Hz
1440x900	60Hz
1920x1080p	60Hz
1920x1200	60Hz; 50Hz

11 Default EDID

Each input on the **DIP-20** is loaded with a factory default EDID.

11.1 HDMI

Monitor

Model name.....DIP-20
Manufacturer..... KMR
Plug and Play ID..... KMR1200
Serial number..... n/a
Manufacture date..... 2015, ISO week 255
Filter driver..... None

EDID revision..... 1.3
Input signal type..... Digital
Color bit depth..... Undefined
Display type..... RGB color
Screen size..... 520 x 320 mm (24.0 in)
Power management..... Standby, Suspend, Active off/sleep
Extension blocs..... 1 (CEA-EXT)

DDC/CI..... n/a

Color characteristics

Default color space..... Non-sRGB
Display gamma..... 2.20
Red chromaticity..... Rx 0.674 - Ry 0.319
Green chromaticity..... Gx 0.188 - Gy 0.706
Blue chromaticity..... Bx 0.148 - By 0.064
White point (default).... Wx 0.313 - Wy 0.329
Additional descriptors... None

Timing characteristics

Horizontal scan range.... 30-83kHz
Vertical scan range..... 56-76Hz
Video bandwidth..... 170MHz
CVT standard..... Not supported
GTF standard..... Not supported
Additional descriptors... None
Preferred timing..... Yes
Native/preferred timing.. 1280x720p at 60Hz (16:10)
Modeline..... "1280x720" 74.250 1280 1390 1430 1650 720 725 730 750 +hsync +vsync

Standard timings supported

720 x 400p at 70Hz - IBM VGA
720 x 400p at 88Hz - IBM XGA2
640 x 480p at 60Hz - IBM VGA
640 x 480p at 67Hz - Apple Mac II
640 x 480p at 72Hz - VESA
640 x 480p at 75Hz - VESA
800 x 600p at 56Hz - VESA
800 x 600p at 60Hz - VESA
800 x 600p at 72Hz - VESA
800 x 600p at 75Hz - VESA
832 x 624p at 75Hz - Apple Mac II
1024 x 768i at 87Hz - IBM
1024 x 768p at 60Hz - VESA
1024 x 768p at 70Hz - VESA
1024 x 768p at 75Hz - VESA
1280 x 1024p at 75Hz - VESA
1152 x 870p at 75Hz - Apple Mac II
1280 x 1024p at 75Hz - VESA STD
1280 x 1024p at 85Hz - VESA STD
1600 x 1200p at 60Hz - VESA STD
1024 x 768p at 85Hz - VESA STD

800 x 600p at 85Hz - VESA STD
640 x 480p at 85Hz - VESA STD
1152 x 864p at 70Hz - VESA STD
1280 x 960p at 60Hz - VESA STD

EIA/CEA-861 Information

Revision number..... 3
IT underscan..... Supported
Basic audio..... Supported
YCbCr 4:4:4..... Supported
YCbCr 4:2:2..... Supported
Native formats..... 1
Detailed timing #1..... 1920x1080p at 60Hz (16:10)
 Modeline..... "1920x1080" 148.500 1920 2008 2052 2200 1080 1084 1089 1125 +hsync +vsync
Detailed timing #2..... 1920x1080i at 60Hz (16:10)
 Modeline..... "1920x1080" 74.250 1920 2008 2052 2200 1080 1084 1094 1124 interlace +hsync
+vsync
Detailed timing #3..... 1280x720p at 60Hz (16:10)
 Modeline..... "1280x720" 74.250 1280 1390 1430 1650 720 725 730 750 +hsync +vsync
Detailed timing #4..... 720x480p at 60Hz (16:10)
 Modeline..... "720x480" 27.000 720 736 798 858 480 489 495 525 -hsync -vsync

CE audio data (formats supported)

LPCM 2-channel, 16/20/24 bit depths at 32/44/48 kHz

CE video identifiers (VICs) - timing/formats supported

1920 x 1080p at 60Hz - HDTV (16:9, 1:1)
1920 x 1080i at 60Hz - HDTV (16:9, 1:1)
1280 x 720p at 60Hz - HDTV (16:9, 1:1) [Native]
720 x 480p at 60Hz - EDTV (16:9, 32:27)
720 x 480p at 60Hz - EDTV (4:3, 8:9)
720 x 480i at 60Hz - Doublescan (16:9, 32:27)
720 x 576i at 50Hz - Doublescan (16:9, 64:45)
640 x 480p at 60Hz - Default (4:3, 1:1)
NB: NTSC refresh rate = (Hz*1000)/1001

CE vendor specific data (VSDB)

IEEE registration number. 0x000C03
CEC physical address..... 1.0.0.0
Maximum TMDs clock..... 165MHz

CE speaker allocation data

Channel configuration... 2.0
Front left/right..... Yes
Front LFE..... No
Front center..... No
Rear left/right..... No
Rear center..... No
Front left/right center.. No
Rear left/right center... No
Rear LFE..... No

Report information

Date generated..... 09/08/2015
Software revision..... 2.60.0.972
Data source..... File
Operating system..... 6.1.7601.2.Service Pack 1

Raw data

00,FF,FF,FF,FF,FF,FF,00,2D,B2,00,12,00,00,00,00,FF,19,01,03,80,34,20,78,EA,B3,25,AC,51,30,B4,26,
10,50,54,FF,FF,80,81,8F,81,99,A9,40,61,59,45,59,31,59,71,4A,81,40,01,1D,00,72,51,D0,1E,20,6E,28,
55,00,07,44,21,00,00,1E,00,00,00,FD,00,38,4C,1E,53,11,00,0A,20,20,20,20,20,00,00,00,FC,00,41,
56,53,2D,33,32,20,20,20,20,20,00,00,00,00,00,00,00,00,00,00,00,00,00,00,00,00,00,00,01,B7,
02,03,1B,F1,23,09,07,07,48,10,05,84,03,02,07,16,01,65,03,0C,00,10,00,83,01,00,00,02,3A,80,18,71,
38,2D,40,58,2C,45,00,07,44,21,00,00,1E,01,1D,80,18,71,1C,16,20,58,2C,25,00,07,44,21,00,00,9E,01,
1D,00,72,51,D0,1E,20,6E,28,55,00,07,44,21,00,00,1E,8C,0A,D0,8A,20,E0,2D,10,10,3E,96,00,07,44,21,
00,00,18,00,47

11.2 PC-UXGA

Monitor

Model name..... DIP-20
Manufacturer..... KMR
Plug and Play ID..... KMR1200
Serial number..... n/a
Manufacture date..... 2015, ISO week 255
Filter driver..... None

EDID revision..... 1.3
Input signal type..... Analog 0.700,0.000 (0.7V p-p)
Sync input support..... Separate, Composite, Sync-on-green
Display type..... RGB color
Screen size..... 520 x 320 mm (24.0 in)
Power management..... Standby, Suspend, Active off/sleep
Extension blocs..... None

DDC/CI..... n/a

Color characteristics

Default color space..... sRGB
Display gamma..... 2.20
Red chromaticity..... Rx 0.674 - Ry 0.319
Green chromaticity..... Gx 0.188 - Gy 0.706
Blue chromaticity..... Bx 0.148 - By 0.064
White point (default).... Wx 0.313 - Wy 0.329
Additional descriptors... None

Timing characteristics

Horizontal scan range.... 30-83kHz
Vertical scan range..... 56-76Hz
Video bandwidth..... 170MHz
CVT standard..... Not supported
GTF standard..... Not supported
Additional descriptors... None
Preferred timing..... Yes
Native/preferred timing.. 1280x720p at 60Hz (16:10)
Modeline..... "1280x720" 74.250 1280 1390 1430 1650 720 725 730 750 +hsync +vsync

Standard timings supported

720 x 400p at 70Hz - IBM VGA
720 x 400p at 88Hz - IBM XGA2
640 x 480p at 60Hz - IBM VGA
640 x 480p at 67Hz - Apple Mac II
640 x 480p at 72Hz - VESA
640 x 480p at 75Hz - VESA
800 x 600p at 56Hz - VESA
800 x 600p at 60Hz - VESA
800 x 600p at 72Hz - VESA
800 x 600p at 75Hz - VESA
832 x 624p at 75Hz - Apple Mac II
1024 x 768i at 87Hz - IBM
1024 x 768p at 60Hz - VESA
1024 x 768p at 70Hz - VESA
1024 x 768p at 75Hz - VESA
1280 x 1024p at 75Hz - VESA
1152 x 870p at 75Hz - Apple Mac II
1280 x 1024p at 75Hz - VESA STD
1280 x 1024p at 85Hz - VESA STD
1600 x 1200p at 60Hz - VESA STD
1024 x 768p at 85Hz - VESA STD
800 x 600p at 85Hz - VESA STD
640 x 480p at 85Hz - VESA STD
1152 x 864p at 70Hz - VESA STD
1280 x 960p at 60Hz - VESA STD

EIA/CEA-861 Information

Revision number..... 3
IT underscan..... Supported

12 Protocol 3000

The **Automatic** Video Switcher can be operated using serial commands from a PC, remote controller or touch screen using the Kramer Protocol 3000.

This section describes:

- Kramer Protocol 3000 syntax (see [Section 12.1](#))
- Kramer Protocol 3000 commands (see [Section 12.1.8](#))

12.1 Kramer Protocol 3000 Syntax

12.1.1 Host Message Format

Start	Address (optional)	Body	Delimiter
#	<i>Device_id@</i>	Message	CR

12.1.1.1 Simple Command

Command string with only one command without addressing:

Start	Body	Delimiter
#	Command SP <i>Parameter_1,Parameter_2,...</i>	CR

12.1.1.2 Command String

Formal syntax with commands concatenation and addressing:

Start	Address	Body	Delimiter
#	<i>Device_id@</i>	Command_1 <i>Parameter1_1,Parameter1_2,...</i> Command_2 <i>Parameter2_1,Parameter2_2,...</i> Command_3 <i>Parameter3_1,Parameter3_2,...</i> ...	CR

12.1.2 Device Message Format

Start	Address (optional)	Body	Delimiter
~	<i>Device_id@</i>	Message	CR LF

12.1.2.1 Device Long Response

Echoing command:

Start	Address (optional)	Body	Delimiter
~	<i>Device_id@</i>	Command SP [<i>Param1 ,Param2 ...</i>] result	CR LF

CR = Carriage return (ASCII 13 = 0x0D)

LF = Line feed (ASCII 10 = 0x0A)

SP = Space (ASCII 32 = 0x20)

12.1.3 Command Terms

Command

A sequence of ASCII letters ('A'-'Z', 'a'-'z' and '-').

Command and parameters must be separated by at least one space.

Parameters

A sequence of alphanumeric ASCII characters ('0'-'9', 'A'-'Z', 'a'-'z' and some special characters for specific commands). Parameters are separated by commas.

Message string

Every command entered as part of a message string begins with a **message starting character** and ends with a **message closing character**.

Note: A string can contain more than one command. Commands are separated by a pipe ('|') character.

Message starting character

'#' – For host command/query

'~' – For device response

Device address (Optional, for K-NET)

K-NET Device ID followed by '@'

Query sign

'?' follows some commands to define a query request.

Message closing character

CR – For host messages; carriage return (ASCII 13)

CRLF – For device messages; carriage return (ASCII 13) + line-feed (ASCII 10)

Command chain separator character

When a message string contains more than one command, a pipe ('|') character separates each command.

Spaces between parameters or command terms are ignored.

12.1.4 Entering Commands

You can directly enter all commands using a terminal with ASCII communications software, such as HyperTerminal, Hercules, etc. Connect the terminal to the serial or Ethernet port on the Kramer device. To enter **CR** press the Enter key.

(**LF** is also sent but is ignored by command parser).

For commands sent from some non-Kramer controllers like Crestron, some characters require special coding (such as, /X##). Refer to the controller manual.

12.1.5 Command Forms

Some commands have short name syntax in addition to long name syntax to allow faster typing. The response is always in long syntax.

12.1.6 Chaining Commands

Multiple commands can be chained in the same string. Each command is delimited by a pipe character ("|"). When chaining commands, enter the **message starting character** and the **message closing character** only once, at the beginning of the string and at the end.

Commands in the string do not execute until the closing character is entered.

A separate response is sent for every command in the chain.

12.1.7 Maximum String Length

64 characters

12.1.8 System Commands

Command	Description
#	Protocol handshaking
BUILD-DATE?	Get device build date
FACTORY	Reset to factory default configuration
HELP	Get command list
MODEL?	Get device model
PROT-VER?	Get device protocol version
RESET	Reset device
SN?	Get device serial number
VERSION?	Get device firmware version
AV-SW-MODE	Set/get auto switch mode
AV-SW-TIMEOUT	Set/get auto switching timeout
DISPLAY?	Get output HPD status
FPGA-VER?	Get current FPGA version
HDCP-MOD	Set/get HDCP mode
HDCP-STAT?	Get HDCP signal status
LDFW	Load new firmware file
NAME	Set/get machine (DNS) name
NAME-RST	Reset machine name to factory default (DNS)
PRIORITY	Set/get priority for all channels
SIGNAL?	Get input signal lock status

Command - #		Command Type - System-mandatory	
Command Name		Permission	Transparency
Set:	#	End User	Public
Get:	-	-	-
Description		Syntax	
Set:	Protocol handshaking	# <input type="text"/>	
Get:	-	-	
Response			
~ <input type="text"/> @ <input type="text"/> SPOK _{CR LF}			
Parameters			
Response Triggers			
Notes			
Validates the Protocol 3000 connection and gets the machine number Step-in master products use this command to identify the availability of a device			

Command - BUILD-DATE		Command Type - System-mandatory	
Command Name		Permission	Transparency
Set:	-	-	-
Get:	BUILD-DATE?	End User	Public
Description		Syntax	
Set:	Get device build date	#BUILD-DATE <input type="text"/>	
Get:	-	-	
Response			
~ <input type="text"/> @BUILD-DATE <input type="text"/> SPdate <input type="text"/> SPtime _{CR LF}			
Parameters			
<i>date</i> - Format: YYYY/MM/DD where YYYY = Year, MM = Month, DD = Day <i>time</i> - Format: hh:mm:ss where hh = hours, mm = minutes, ss = seconds			
Response Triggers			
Notes			

Command - HELP		Command Type - System-mandatory	
Command Name		Permission	Transparency
Set:	-	-	-
Get:	HELP	End User	Public
Description		Syntax	
Set:	-	-	
Get:	Get command list or help for specific command	2 options: 1. #HELP _{CR} 2. #HELP _{SP} <i>command_name</i> _{CR}	
Response			
1. Multi-line: ~nn@Device available protocol 3000 commands: _{CR LF} <i>command</i> _{SP} <i>command...</i> _{CR LF}			
To get help for command use: HELP (COMMAND_NAME) _{CR LF}			
2. Multi-line: ~nn@HELP _{SP} <i>command</i> : _{CR LF} <i>description</i> _{CR LF} USAGE: <i>usage</i> _{CR LF}			
Parameters			
Response Triggers			
Notes			

Command - MODEL?		Command Type - System-mandatory	
Command Name		Permission	Transparency
Set:	-	-	-
Get:	MODEL?	End User	Public
Description		Syntax	
Set:	-	-	
Get:	Get device model	#MODEL? _{CR}	
Response			
~nn@MODEL _{SP} <i>model_name</i> _{CR LF}			
Parameters			
model_name - String of up to 19 printable ASCII chars			
Response Triggers			
Notes			
This command identifies equipment connected to Step-in master products and notifies of identity changes to the connected equipment. The Matrix saves this data in memory to answer REMOTE-INFO requests			

Command - PROT-VER?		Command Type - System-mandatory	
Command Name		Permission	Transparency
Set:	-	-	-
Get:	PROT-VER?	End User	Public
Description		Syntax	
Set:	-	-	
Get:	Get device protocol version	# PROT-VER? <input type="checkbox"/> CR	
Response			
~nn@ PROT-VER <input type="checkbox"/> SP3000:version <input type="checkbox"/> CR LF			
Parameters			
Version - XX.XX where X is a decimal digit			
Response Triggers			
Notes			

Command - RESET		Command Type - System-mandatory	
Command Name		Permission	Transparency
Set:	RESET	Administrator	Public
Get:	-	-	-
Description		Syntax	
Set:	Reset device	# RESET <input type="checkbox"/> CR	
Get:	-	-	
Response			
~nn@ RESET <input type="checkbox"/> SPOK <input type="checkbox"/> CR LF			
Parameters			
Response Triggers			
Notes			
To avoid locking the port due to a USB bug in Windows, disconnect USB connections immediately after running this command. If the port was locked, disconnect and reconnect the cable to reopen the port.			

Command - SN?		Command Type - System-mandatory	
Command Name		Permission	Transparency
Set:	-	-	-
Get:	SN?	End User	Public
Description		Syntax	
Set:	-	-	
Get:	Get device serial number	# SN? _{CR}	
Response			
~ nn @ SN _{SP} serial_number _{CR LF}			
Parameters			
serial_number - 11 decimal digits, factory assigned			
Response Triggers			
Notes			
For new products with 14 digit serial numbers, use only the last 11 digits			

Command - VERSION?		Command Type - System-mandatory	
Command Name		Permission	Transparency
Set:	-	-	-
Get:	VERSION?	End User	Public
Description		Syntax	
Set:	-	-	
Get:	Get firmware version number	# VERSION? _{CR}	
Response			
~ nn @ VERSION _{SP} firmware_version _{CR LF}			
Parameters			
firmware_version - XX.XX.XXXX where the digit groups are: major.minor.build version			
Response Triggers			
Notes			

Command - AV-SW-MODE		Command Type - System	
Command Name		Permission	Transparency
Set:	AV-SW-MODE	End user	Public
Get:	AV-SW-MODE?	End user	Public
Description		Syntax	
Set:	Set input auto switch mode (per output)	# AV-SW-MODE _{SP} layer,output_id,mode _{CR LF}	
Get:	Get input auto switch mode (per output)	# AV-SW-MODE? _{SP} layer,output_id _{CR}	
Response			
~ _{nn} @AV-SW-MODE _{SP} layer,output_id,mode _{CR LF}			
Parameters			
layer (see Section 12.1.17)			
output_id - 1...num of system outputs			
mode - 0 - manual			
1 - priority switch			
2 - last connected switch			
Response Triggers			
Notes			

Command - AV-SW-TIMEOUT		Command Type - System	
Command Name		Permission	Transparency
Set:	AV-SW-TIMEOUT	End User	Public
Get:	AV-SW-TIMEOUT?	End User	Public
Description		Syntax	
Set:	Set auto switching timeout	#AV-SW-TIMEOUT _{SP} action,time_out _{CR}	
Get:	Get auto switching timeout	#AV-SW-TIMEOUT? _{SP} action _{CR}	
Response			
~ _{nn} @AV-SW-TIMEOUT _{SP} action,time_out _{CR}			
Parameters			
action (see Section 12.1.18)			
timeout - timeout in seconds			
Response Triggers			
Notes			

Command - DISPLAY?		Command Type - System	
Command Name		Permission	Transparency
Set:	-	-	-
Get:	DISPLAY?	End User	Public
Description		Syntax	
Set:	-	-	
Get:	Get output HPD status	# DISPLAY? _{SP} out_id _{CR}	
Response			
~ _{hh} @ DISPLAY _{SP} out_id,status _{CR LF}			
Parameters			
out_id - output number status - HPD status according to signal validation			
Response Triggers			
After execution, response is sent to the com port from which the Get was received Response is sent after every change in output HPD status ON to OFF Response is sent after every change in output HPD status OFF to ON and ALL parameters (new EDID, etc.) are stable and valid			
Notes			

Command - FPGA-VER?		Command Type - System	
Command Name		Permission	Transparency
Set:	-	-	-
Get:	FPGA-VER?	End User	Public
Description		Syntax	
Set:	-	-	
Get:	Get current FPGA version	# FPGA-VER? _{SP} id _{CR}	
Response			
~ _{hh} @ FPGA-VER _{SP} id, expected_ver, actual_ver _{CR LF}			
Parameters			
id - FPGA id expected_ver - expected FPGA version for current firmware actual_ver - actual FPGA version			
Response Triggers			
Notes			

Command - HDCP-MOD		Command Type - System	
Command Name		Permission	Transparency
Set:	HDCP-MOD	Administrator	Public
Get:	HDCP-MOD?	End User	Public
Description		Syntax	
Set:	Set HDCP mode	#HDCP-MOD _{SP} inp_id,mode _{CR}	
Get:	Get HDCP mode	#HDCP-MOD? _{SP} stage_id _{CR}	
Response			
Set / Get: ~ _{NN} @HDCP-MOD _{SP} stage_id,mode _{CR LF}			
Parameters			
inp_id - input number (1.. max number of inputs)			
mode - HDCP mode			
Response Triggers			
Response is sent to the com port from which the Set (before execution) / Get command was received			
Response is sent to all com ports after execution if HDCP-MOD was set by any other external control device (button press, device menu and similar) or HDCP mode changed			
Notes			
Set HDCP working mode on the device input: HDCP supported - HDCP_ON [default] HDCP not supported - HDCP OFF HDCP support changes following detected sink - MIRROR OUTPUT			

Command - HDCP-STAT		Command Type - System	
Command Name		Permission	Transparency
Set:	-	-	-
Get:	HDCP-STAT?	End User	Public
Description		Syntax	
Set:	None	-	
Get:	Get HDCP signal status	#HDCP-STAT? _{SP} stage,stage_id _{CR}	
Response			
Set / Get: - _{nr} @HDCP-STAT _{SP} stage,stage_id,mode _{CR LF}			
Parameters			
<i>stage</i> – input/output <i>stage_id</i> - number of chosen stage (1.. max number of inputs/outputs) <i>actual_status</i> - signal encryption status - valid values ON/OFF			
Response Triggers			
Response is sent to the com port from which the Set (before execution) / Get command was received Response is sent to all com ports after execution if HDCP-STAT was set by any other external control device (button press, device menu and similar) or HDCP mode changed			
Notes			
On output – sink status On input – signal status			

Command - LDFW		Command Type - System - Packets	
Command Name		Permission	Transparency
Set:	LDFW	Internal SW	Public
Get:	-	-	-
Description		Syntax	
Set:	Load new firmware file	Step 1: # LDFW _{SP} size _{CR} Step 2: If ready was received, send FIRMWARE_DATA	
Get:	-	-	
Response			
Response 1: ~ nn @ LDFW _{SP} size _{SP} READY _{CR LF} or ~ nn @ LDFW _{SP} ERRnn _{CR LF}			
Response 2: ~ nn @ LDFW _{SP} size _{SP} OK _{CR LF}			
Parameters			
<i>size</i> - size of firmware data that is sent			
FIRMWARE_DATA - HEX or KFW file in protocol packets (see Section 4)			
Response Triggers			
Notes			
In most devices firmware data is saved to flash memory, but the memory does not update until receiving the "UPGRADE" command and is restarted. Use this command in dedicated SW application			

Command - NAME		Command Type - System (Ethernet)	
Command Name		Permission	Transparency
Set:	NAME	Administrator	Public
Get:	NAME?	End User	Public
Description		Syntax	
Set:	Set machine (DNS) name	# NAME _{SP} <i>machine_name</i> _{CR}	
Get:	Get machine (DNS) name	# NAME? _{CR}	
Response			
Set: ~ nn @ NAME _{SP} <i>machine_name</i> _{CR LF}			
Get: ~ nn @ NAME? _{SP} <i>machine_name</i> _{CR LF}			
Parameters			
<i>machine_name</i> - String of up to 14 alpha-numeric chars (can include hyphen, not at the beginning or end)			
Response Triggers			
Notes			
The machine name is not the same as the model name. The machine name is used to identify a specific machine or a network in use (with DNS feature on)			

Command - NAME-RST		Command Type - System (Ethernet)	
Command Name		Permission	Transparency
Set:	NAME-RST	Administrator	Public
Get:	-	-	-
Description		Syntax	
Set:	Reset machine (DNS) name to factory default	# NAME-RST <input type="checkbox"/>	
Get:	-	-	
Response			
~ <input type="checkbox"/> @ NAME-RST <input type="checkbox"/> OK <input type="checkbox"/>			
Parameters			
Response Triggers			
Notes			
Factory default of machine (DNS) name is "KRAMER_" + 4 last digits of device serial number			

Command - PRIORITY		Command Type - System	
Command Name		Permission	Transparency
Set:	PRIORITY	Administrator	Public
Get:	PRIORITY?	Administrator	Public
Description		Syntax	
Set:	Set input priority	# PRIORITY <input type="checkbox"/> layer,PRIORITY1, PRIORITY2... PRIORITYn <input type="checkbox"/>	
Get:	Get input priority	# PRIORITY? layer <input type="checkbox"/>	
Response			
~ <input type="checkbox"/> @ PRIORITY <input type="checkbox"/> layer,PRIORITY1, PRIORITY2... PRIORITYn <input type="checkbox"/>			
Parameters			
layer (see Section 12.1.17) PRIORITY1 - priority of first input PRIORITYn- priority of input n			
Response Triggers			
Notes			
WP-577VH – layer parameter is not used			

Command - SIGNAL		Command Type - System	
Command Name		Permission	Transparency
Set:	-	-	-
Get	SIGNAL?	End User	Public
Description		Syntax	
Set:	-	-	
Get:	Get input signal lock status	# SIGNAL? _{SP} <i>inp_id</i> _{CR}	
Response			
~ <i>nn</i> @ SIGNAL _{SP} <i>inp_id,status</i> _{CR LF}			
Parameters			
<i>inp_id</i> - input number <i>status</i> - lock status according to signal validation			
Response Triggers			
After execution, a response is sent to the com port from which the Get was received Response is sent after every change in input signal status ON to OFF, or OFF to ON			
Notes			

12.1.9 File System Commands

Command	Description
DEL	Delete file
DIR	List files in device
FORMAT	Format file system
FS-FREE?	Get file system free space
GET	Get file
LOAD	Load file to device

Command - DEL		Command Type - File System	
Command Name		Permission	Transparency
Set:	DEL	Administrator	Public
Get:	-	-	-
Description		Syntax	
Set:	Delete file	#DEL _{SP} file_name _{CR LF}	
Get:			
Response			
-nn@DEL _{SP} file_name _{CR LF}			
Parameters			
file_name - name of file to delete (file names are case-sensitive)			
Response Triggers			
Notes			

Command - DIR		Command Type - File System	
Command Name		Permission	Transparency
Set:	DIR	Administrator	Public
Get:	-	-	-
Description		Syntax	
Set:	List files in device	#DIR _{CR}	
Get:	-	-	
Response			
Multi Line:			
~nn@DIR _{CR LF}			
file_name _{TAB} file_size _{SP} bytes _{SP} ID _{SP} file_id _{CR LF}			
_{TAB} free_size _{SP} bytes _{CR LF}			
Parameters			
file_name - name of file			
file_size - file size in bytes. A file can take more space on device memory			
file_id - internal ID for file in file system			
free_size - free space in bytes in device file system			
Response Triggers			
Notes			

Command - FORMAT		Command Type - File System	
Command Name		Permission	Transparency
Set:	FORMAT	Administrator	Public
Get:	-	-	-
Description		Syntax	
Set:	Format file system	#FORMAT _{CR}	
Get:	-	-	
Response			
~nn@FORMAT _{SP} OK _{CR LF}			
Parameters			
Response Triggers			
Notes			
Response could take some time (seconds) until formatting completes			

Command - FS-FREE?		Command Type - File System	
Command Name		Permission	Transparency
Set:	-	-	-
Get:	FS-FREE?	Administrator	Public
Description		Syntax	
Set:	-	-	
Get:	Get file system free space	#FS-FREE? <input type="checkbox"/> CR	
Response			
- <input type="checkbox"/> <input type="checkbox"/> @FS_FREE <input type="checkbox"/> free_size <input type="checkbox"/> CR LF			
Parameters			
<i>free_size</i> - free size in device file system in bytes			
Response Triggers			
Notes			

Command - GET		Command Type - File System	
Command Name		Permission	Transparency
Set:	-	-	-
Get:	GET	Administrator	Public
Description		Syntax	
Set:	-	-	
Get:	Get file	#GET <input type="checkbox"/> file_name <input type="checkbox"/> CR	
Response			
Multi-line:			
- <input type="checkbox"/> <input type="checkbox"/> @GET <input type="checkbox"/> file_name, file_size <input type="checkbox"/> READY <input type="checkbox"/> CR LF			
<i>contents</i>			
- <input type="checkbox"/> <input type="checkbox"/> @GET <input type="checkbox"/> file_name <input type="checkbox"/> OK <input type="checkbox"/> CR LF			
Parameters			
<i>file_name</i> - name of file to get contents			
<i>contents</i> - byte stream of file contents			
<i>file_size</i> - size of file (device sends it in response to give user a chance to get ready)			
Response Triggers			
Notes			

Command - LOAD		Command Type - System - Packets	
Command Name		Permission	Transparency
Set:	LOAD	Administrator	Public
Get:	-	-	-
Description		Syntax	
Set:	Load file to device	#LOAD _{SP} file_name,size _{CR}	
Get:	-	-	
Response			
Data sending negotiation:			
* Device -			
-01@LOAD _{SP} file_name,size _{SP} READY _{CR LF}			
* End User (+Device)-			
Send file in Protocol Packets			
* Device -			
-01@LOAD _{SP} file_name, size _{SP} OK _{CR LF}			
Parameters			
file_name - name of file to save on device			
size - size of file data that is sent.			
Response Triggers			
Notes			
See the Protocol Packet reference			

12.1.10 Authentication Commands

Command	Description
LOGIN	Set/get protocol permission
LOGOUT	Cancel current permission level
PASS	Set/get password for login level
SECUR	Set/get current security state

Command - LOGIN		Command Type - Authentication	
Command Name		Permission	Transparency
Set:	LOGIN	Not Secure	Public
Get:	LOGIN?	Not Secure	Public
Description		Syntax	
Set:	Set protocol permission	#LOGIN _[SP] login_level,password _[CR]	
Get:	Get current protocol permission level	#LOGIN? _[CR]	
Response			
Set: ~nn@LOGIN _[SP] login_level,password _[SP] OK _[CR LF] or ~nn@LOGIN _[SP] ERR _[SP] 004 _[CR LF] (if bad password entered) Get: ~nn@LOGIN _[SP] login_level _[CR LF]			
Parameters			
<i>login_level</i> - level of permissions required (End User or Admin) <i>password</i> - predefined password (by PASS command). Default password is an empty string			
Response Triggers			
Notes			
For devices that support security, LOGIN allows to the user to run commands with an End User or Administrator permission level In each device, some connections can be logged in to different levels and some do not work with security at all Connection may logout after timeout The permission system works only if security is enabled with the "SECUR" command			

Command - LOGOUT		Command Type - Authentication	
Command Name		Permission	Transparency
Set:	LOGOUT	Not Secure	Public
Get:	-	-	-
Description		Syntax	
Set:	Cancel current permission level	# LOGOUT <input type="checkbox"/>	
Get:	-	-	
Response			
- <input type="checkbox"/> @ LOGOUT <input type="checkbox"/> OK <input type="checkbox"/>			
Parameters			
Response Triggers			
Notes			
Logs out from End User or Administrator permission levels to Not Secure			

Command - PASS		Command Type - Authentication	
Command Name		Permission	Transparency
Set:	PASS	Administrator	Public
Get:	PASS?	Administrator	Public
Description		Syntax	
Set:	Set password for login level	# PASS <input type="checkbox"/> login_level, password <input type="checkbox"/>	
Get:	Get password for login level	# PASS? <input type="checkbox"/> login_level <input type="checkbox"/>	
Response			
- <input type="checkbox"/> @ PASS <input type="checkbox"/> login_level, password <input type="checkbox"/>			
Parameters			
login_level - level of login to set (End User or Administrator). password - password for the login_level. Up to 15 printable ASCII chars			
Response Triggers			
Notes			
The default password is an empty string			

Command - SECUR		Command Type - Authentication	
Command Name		Permission	Transparency
Set:	SECUR	Administrator	Public
Get:	SECUR?	Not Secure	Public
Description		Syntax	
Set:	Start/stop security	# SECUR _{SP} security_mode _{CR}	
Get:	Get current security state	# SECUR? _{CR}	
Response			
~ _{hh} @ SECUR _{SP} security_mode _{CR LF}			
Parameters			
security_mode – 1/ON - enables security, 0/OFF - disables security			
Response Triggers			
Notes			
The permission system works only if security is enabled with the "SECUR" command			

12.1.11 Switching/Routing Commands

Command	Description
ROUTE	Set/get layer routing

Command - ROUTE		Command Type - Routing	
Command Name		Permission	Transparency
Set:	ROUTE	End User	Public
Get:	ROUTE?	End User	Public
Description		Syntax	
Set:	Set layer routing	#ROUTE _{SP} /layer, dest, src _{CR}	
Get:	Get layer routing	#ROUTE? _{SP} /layer, dest _{CR}	
Response			
~nn@ ROUTE _{SP} /layer, dest, src _{CR LF}			
Parameters			
<i>layer</i> (see Section 12.1.17) <i>dest</i> - * - ALL x - disconnect, otherwise destination id <i>src</i> - source id			
Response Triggers			
Notes			
This command replaces all other routing commands The GET command identifies input switching on Step-in clients The SET command is for remote input switching on Step-in clients (essentially via by the Web)			

12.1.12 Video Commands

Command	Description
VMUTE	Set/get video on output mute

Command - VMUTE		Command Type - Video	
Command Name		Permission	Transparency
Set:	VMUTE	End User	Public
Get:	VMUTE?	End User	Public
Description		Syntax	
Set:	Set enable/disable video on output	#VMUTE _{SP} output_id, flag _{CR}	
Get:	Get video on output status	#VMUTE? _{SP} output_id _{SP} _{CR}	
Response			
Set / Get: ~ _{hn} @ VMUTE _{SP} output_id, flag _{CR LF}			
Parameters			
<i>output_id</i> - 1...num of system outputs <i>flag</i> - 0 - disable video on output 1 - enable video on output 2 - blank video			
Response Triggers			
Notes			

12.1.13 Audio Commands

Command	Description
AUD-EMB	Set/get audio in video embedding status
AUD-LVL	Set/get audio level in specific amplifier stage
AUD-SIGNAL?	Get audio input signal status

Command - AUD-EMB		Command Type - Audio	
Command Name		Permission	Transparency
Set:	AUD-EMB	End User	Public
Get:	AUD-EMB?	End User	Public
Description		Syntax	
Set:	Set audio in video embedding status	#AUD-EMB _{SP} _{in,out,status} _{CR}	
Get:	Get audio in video embedding status	#AUD-EMB? _{SP} _{in,out} _{CR}	
Response			
Set/Get: ~ _{in} @AUD-EMB _{SP} _{in,out,status} _{CR LF}			
Parameters			
<i>in</i> - audio input to be embedded number (1... max number of inputs)			
<i>out</i> - video output to embed into number (1 .. max number of outputs)			
<i>status</i> - embedded (ON), or not (OFF) status			
Response Triggers			
Response is sent to the com port from which the Set (before execution)/Get command was received			
After execution, response is sent to all com ports if AUD-EMB was set by any other external control device (button press, device menu and similar)			
Notes			

Command - AUD-LVL		Command Type - Audio	
Command Name		Permission	Transparency
Set:	AUD-LVL	End User	Public
Get:	AUD-LVL?	End User	Public
Description		Syntax	
Set:	Set audio level in specific amplifier stage	# AUD-LVL _{SP} stage, channel, volume _{CR LF}	
Get:	Get audio level in specific amplifier stage	# AUD-LVL? _{SP} stage, channe _{CR}	
Response			
~ nn @ AUD-LVL _{SP} stage, channel, volume _{CR LF}			
Parameters			
<i>stage</i> - input/output or numeric value of present audio processing stage For example: '1' for input level, '2' for output <i>channel</i> - input or output number <i>volume</i> - audio parameter in Kramer units, minus sign precedes negative values. ++ increase current value, -- decrease current value			
Response Triggers			
Notes			
Command - AUD-SIGNAL		Command Type - Audio	
Command Name		Permission	Transparency
Set:	-	-	-
Get:	AUD-SIGNAL?	End User	Public
Description		Syntax	
Set:	-	-	
Get:	Get audio input signal status	# AUD-SIGNAL? _{SP} inp_id _{CR}	
Response			
~ nn @ AUD-SIGNAL _{SP} inp_id, status _{CR LF}			
Parameters			
<i>inp_id</i> - input number (1 .. max input number) <i>status</i> - 0 - OFF (no signal) 1 - ON (signal present)			
Response Triggers			
After execution, response is sent to the com port from which the Get was received Response is sent to all com ports if audio status state was changed on any input			
Notes			

Command - MUTE		Command Type - Audio	
Command Name		Permission	Transparency
Set:	MUTE	End User	Public
Get:	MUTE?	End User	Public
Description		Syntax	
Set:	Set audio mute	#MUTE _{SP} channel,mute_mode _{CR}	
Get:	Get audio mute	#MUTE? _{SP} channel _{CR}	
Response			
~ _{hh} @MUTE _{SP} channel,mute_mode _{CR LF}			
Parameters			
<i>channel</i> - output number			
<i>mute_mode</i> - 0 or OFF / 1 or ON			
Response Triggers			
Notes			

12.1.14 Communication Commands

Command	Description
ETH-PORT	Set/get Ethernet port protocol
NET-DHCP	Set/get DHCP mode
NET-GATE	Set/get gateway IP
NET-IP	Set/get IP address
NET-MAC?	Get MAC address
NET-MASK	Set/get subnet mask

Command - ETH-PORT		Command Type - Communication	
Command Name		Permission	Transparency
Set:	ETH-PORT	Administrator	Public
Get:	ETH-PORT?	End User	Public
Description		Syntax	
Set:	Set Ethernet port protocol	# ETH-PORT _[SP] <i>portType</i> , <i>ETHPort</i> _[CR]	
Get:	Get Ethernet port protocol	# ETH-PORT? _[SP] <i>portType</i> _[CR]	
Response			
~ nn @ ETH-PORT _[SP] <i>portType</i> , <i>ETHPort</i> _[CR LF]			
Parameters			
<i>portType</i> - TCP/UDP			
<i>ETHPort</i> - TCP/UDP port number			
Response Triggers			
Notes			

Command - NET-DHCP		Command Type - Communication	
Command Name		Permission	Transparency
Set:	NET-DHCP	Administrator	Public
Get:	NET-DHCP?	End User	Public
Description		Syntax	
Set:	Set DHCP mode	# NET-DHCP _{SP} mode _{CR}	
Get:	Get DHCP mode	# NET-DHCP? _{CR}	
Response			
- _{nn} @ NET-DHCP _{SP} mode _{CR LF}			
Parameters			
mode - 0 - Do not use DHCP. Use the IP set by the factory or using the IP set command 1 - Try to use DHCP. If unavailable, use IP as above			
Response Triggers			
Notes			
Connecting Ethernet to devices with DHCP may take more time in some networks To connect with a randomly assigned IP by DHCP, specify the device DNS name (if available) using the command "NAME". You can also get an assigned IP by direct connection to USB or RS-232 protocol port if available For proper settings consult your network administrator			

Command - NET-GATE		Command Type - Communication	
Command Name		Permission	Transparency
Set:	NET-GATE	Administrator	Public
Get:	NET-GATE?	End User	Public
Description		Syntax	
Set:	Set gateway IP	# NET-GATE _{SP} ip_address _{CR}	
Get:	Get gateway IP	# NET-GATE? _{CR}	
Response			
- _{nn} @ NET-GATE _{SP} ip_address _{CR LF}			
Parameters			
ip_address - format: xxx.xxx.xxx.xxx			
Response Triggers			
Notes			
A network gateway connects the device via another network and maybe over the Internet. Be careful of security problems. For proper settings consult your network administrator			

Command - NET-IP		Command Type - Communication	
Command Name		Permission	Transparency
Set:	NET-IP	Administrator	Public
Get:	NET-IP?	End User	Public
Description		Syntax	
Set:	Set IP address	# NET-IP _[SP] <i>ip_address</i> _[CR]	
Get:	Get IP address	# NET-IP? _[CR]	
Response			
~ nn @ NET-IP _[SP] <i>ip_address</i> _[CR LF]			
Parameters			
<i>ip_address</i> - format: xxx.xxx.xxx.xxx			
Response Triggers			
Notes			
For proper settings consult your network administrator			

Command - NET-MAC?		Command Type - Communication	
Command Name		Permission	Transparency
Set:	-	-	-
Get:	NET-MAC?	End User	Public
Description		Syntax	
Set:	-	-	
Get:	Get MAC address	# NET-MAC? _[CR]	
Response			
~ nn @ NET-MAC _[SP] <i>mac_address</i> _[CR LF]			
Parameters			
<i>mac_address</i> - Unique MAC address. Format: XX-XX-XX-XX-XX-XX where X is hex digit			
Response Triggers			
Notes			

Command - NET-MASK		Command Type - Communication	
Command Name		Permission	Transparency
Set:	NET-MASK	Administrator	Public
Get:	NET-MASK?	End User	Public
Description		Syntax	
Set:	Set subnet mask	# NET-MASK <input type="checkbox"/> <i>net_mask</i> <input type="checkbox"/>	
Get:	Get subnet mask	# NET-MASK? <input type="checkbox"/>	
Response			
~ <input type="checkbox"/> @ NET-MASK <input type="checkbox"/> <i>net_mask</i> <input type="checkbox"/> <input type="checkbox"/>			
Parameters			
<i>net_mask</i> - format: xxx.xxx.xxx.xxx			
Response Triggers			
The subnet mask limits the Ethernet connection within the local network For proper settings consult your network administrator			
Notes			

12.1.15 EDID Handling Commands

Command	Description
CPEDID	Copy EDID data from the output to the input EEPROM
GEDID	Set/get EDID data
LDEDID	Load EDID data
LOCK-EDID	Lock last read EDID

Command - CPEDID		Command Type - EDID Handling	
Command Name		Permission	Transparency
Set:	CPEDID	End User	Public
Get:	-	-	-
Description		Syntax	
Set:	Copy EDID data from the output to the input EEPROM	#CPEDID _{SP} src_type, src_id, dst_type, dest_bitmap _{CR}	
Get:	-	-	
Response			
~nn@CPEDID _{SP} src_stg, src_id, dst_type, dest_bitmap _{CR LF}			
Parameters			
<p>src_type - EDID source type (usually output)</p> <p>src_id - number of chosen source stage (1.. max number of inputs/outputs)</p> <p>dst_type - EDID destination type (usually input)</p> <p>dest_bitmap - bitmap representing destination IDs. Format: XXXX...X, where X is hex digit. The binary form of every hex digit represents corresponding destinations. Setting '1' says that EDID data has to be copied to this destination</p>			
Response Triggers			
Response is sent to the com port from which the Set was received (before execution)			
Notes			
<p>Destination bitmap size depends on device properties (for 64 inputs it is a 64-bit word)</p> <p>Example: bitmap 0x0013 means inputs 1,2 and 5 are loaded with the new EDID</p>			

Command - GEDID		Command Type - EDID Handling	
Command Name		Permission	Transparency
Set:	GEDID	Administrator	Public
Get:	GEDID?	End User	Public
Description		Syntax	
Set:	Set EDID data from device	#GEDID _{SP} stage, stage_id _{CR}	
Get:	Get EDID support on certain input/output	#GEDID? _{SP} stage, stage_id _{CR}	
Response			
Set:			
Multi-line response:			
~nn@GEDID _{SP} stage,stage_id,size _{CR LF}			
EDID_data _{CR LF}			
~nn@GEDID _{SP} stage,stage_id _{SP} OK _{CR LF}			
Get:			
~nn@GEDID _{SP} stage,stage_id,size _{CR LF}			
Parameters			
stage - input/output			
stage_id - number of chosen stage (1.. max number of inputs/outputs)			
size - EDID data size. For Set, size of data to be sent from device, for Get, 0 means no EDID support			
Response Triggers			
Response is sent to the com port from which the Set (before execution) / Get command was received			
Notes			
For Get, size=0 means EDID is not supported			
For old devices that do not support this command, ~nn@ ERR 002 _{CR LF} is received			

Command - LDEDID		Command Type - EDID Handling	
Command Name		Permission	Transparency
Set:	LDEDID	End User	Public
Get:	-	-	-
Description		Syntax	
Set:	Write EDID data from external application to device	Multi-step syntax (see following steps)	
Get:	None	None	
Communication Steps (Command and Response)			
<p>Step 1: #LDEDID_[SP]dst_type, dest_bitmask, size, safe_mode_[CR]</p> <p>Response 1: ~nn@LDEDID_[SP]dst_type, dest_bitmask, size, safe_mode_[SP]READY_[CR LF] or ~nn@LDEDID_[SP]ERRnn_[CR LF]</p> <p>Step 2: If ready was received, send EDID_DATA</p> <p>Response 2: ~nn@LDEDID_[SP]dst_type, dest_bitmask, size, safe_mode_[SP]OK_[CR LF] or ~nn@LDEDID_[SP]ERRnn_[CR LF]</p>			
Parameters			
<p>dst_type - EDID destination type (usually input)</p> <p>dest_bitmask - bitmap representing destination IDs. Format: 0x******, where * is ASCII presentation of hex digit. The binary presentation of this number is a bit mask for destinations. Setting '1' means EDID data has to be copied to this destination</p> <p>size - EDID data size</p> <p>safe_mode - 0 - Device accepts the EDID as is without trying to adjust 1 - Device tries to adjust the EDID</p> <p>EDID_DATA - data in protocol packets</p>			
Response Triggers			
Response is sent to the com port from which the Set (before execution)			
Notes			
<p>When the unit receives the LDEDID command it replies with READY and enters the special EDID packet wait mode. In this mode the unit can receive only packets and not regular protocol commands.</p> <p>If the unit does not receive correct packets for 30 seconds or is interrupted for more than 30 seconds before receiving all packets, it sends timeout error ~nn@LDEDID_[SP]ERR01_[CR LF] and returns to the regular protocol mode. If the unit received data that is not a correct packet, it sends the corresponding error and returns to the regular protocol mode.</p> <p>See Protocol Packet reference</p>			

Command – LOCK-EDID		Command Type – EDID Handling	
Command Name		Permission	Command Name
Set:	LOCK-EDID	End User	End User
Get:	LOCK-EDID?	End User	End User
Description		Syntax	
Set:	Lock last read EDID	# LOCK-EDID _{SP} <i>input_id,lock_mode</i> _{CR}	
Get :	Get EDID lock state	# LOCK-EDID? _{SP} <i>input_id</i> _{CR}	
Response			
- nn @ LOCK-EDID _{SP} <i>input_id,lock_mode</i> _{CR LF}			
Parameters			
<i>input_id</i> - 1...num of system inputs			
<i>lock_mode</i> - 0/OFF - unlocks EDID, 1/ON - locks EDID			
Response Triggers			
Notes			

12.1.16 Factory Commands

Command	Description
UPGRADE	Perform firmware upgrade

Command - UPGRADE		Command Type - System	
Command Name		Permission	Transparency
Set:	UPGRADE	Administrator	Internal
Get:	-	-	-
Description		Syntax	
Set:	Perform firmware upgrade	#UPGRADE <input type="checkbox"/> CR	
Get:	-	-	
Response			
~nn@UPGRADE <input type="checkbox"/> SP OK <input type="checkbox"/> CR LF			
Parameters			
Response Triggers			
Notes			
<p>Not necessary for some devices Firmware usually uploads to a device via a command like LDFW Reset the device to complete the process</p>			

12.1.17 Layer

Number	Value
1	Video
2	Audio
3	Data
4	IR
5	USB

12.1.18 Video/Audio Signal Changes

Number	Value
0	Video signal lost
1	New video signal detected
2	Audio signal lost
3	Audio signal detected
4	Disable 5V on video output if no input signal detected
5	Video cable unplugged
6	Audio cable unplugged

LIMITED WARRANTY

The warranty obligations of Kramer Electronics for this product are limited to the terms set forth below:

What is Covered

This limited warranty covers defects in materials and workmanship in this product.

What is Not Covered

This limited warranty does not cover any damage, deterioration or malfunction resulting from any alteration, modification, improper or unreasonable use or maintenance, misuse, abuse, accident, neglect, exposure to excess moisture, fire, improper packing and shipping (such claims must be presented to the carrier), lightning, power surges, or other acts of nature. This limited warranty does not cover any damage, deterioration or malfunction resulting from the installation or removal of this product from any installation, any unauthorized tampering with this product, any repairs attempted by anyone unauthorized by Kramer Electronics to make such repairs, or any other cause which does not relate directly to a defect in materials and/or workmanship of this product. This limited warranty does not cover cartons, equipment enclosures, cables or accessories used in conjunction with this product.

Without limiting any other exclusion herein, Kramer Electronics does not warrant that the product covered hereby, including, without limitation, the technology and/or integrated circuit(s) included in the product, will not become obsolete or that such items are or will remain compatible with any other product or technology with which the product may be used.

How Long Does this Coverage Last

Seven years as of this printing; please check our Web site for the most current and accurate warranty information.

Who is Covered

Only the original purchaser of this product is covered under this limited warranty. This limited warranty is not transferable to subsequent purchasers or owners of this product.

What Kramer Electronics will do

Kramer Electronics will, at its sole option, provide one of the following three remedies to whatever extent it shall deem necessary to satisfy a proper claim under this limited warranty:

1. Elect to repair or facilitate the repair of any defective parts within a reasonable period of time, free of any charge for the necessary parts and labor to complete the repair and restore this product to its proper operating condition. Kramer Electronics will also pay the shipping costs necessary to return this product once the repair is complete.
2. Replace this product with a direct replacement or with a similar product deemed by Kramer Electronics to perform substantially the same function as the original product.
3. Issue a refund of the original purchase price less depreciation to be determined based on the age of the product at the time remedy is sought under this limited warranty.

What Kramer Electronics will not do Under This Limited Warranty

If this product is returned to Kramer Electronics or the authorized dealer from which it was purchased or any other party authorized to repair Kramer Electronics products, this product must be insured during shipment, with the insurance and shipping charges prepaid by you. If this product is returned uninsured, you assume all risks of loss or damage during shipment. Kramer Electronics will not be responsible for any costs related to the removal or re-installation of this product from or into any installation. Kramer Electronics will not be responsible for any costs related to any setting up this product, any adjustment of user controls or any programming required for a specific installation of this product.

How to Obtain a Remedy under this Limited Warranty

To obtain a remedy under this limited warranty, you must contact either the authorized Kramer Electronics reseller from whom you purchased this product or the Kramer Electronics office nearest you. For a list of authorized Kramer Electronics resellers and/or Kramer Electronics authorized service providers, please visit our web site at www.kramerelectronics.com or contact the Kramer Electronics office nearest you.

In order to pursue any remedy under this limited warranty, you must possess an original, dated receipt as proof of purchase from an authorized Kramer Electronics reseller. If this product is returned under this limited warranty, a return authorization number, obtained from Kramer Electronics, will be required. You may also be directed to an authorized reseller or a person authorized by Kramer Electronics to repair the product.

If it is decided that this product should be returned directly to Kramer Electronics, this product should be properly packed, preferably in the original carton, for shipping. Cartons not bearing a return authorization number will be refused.

Limitation on Liability

THE MAXIMUM LIABILITY OF KRAMER ELECTRONICS UNDER THIS LIMITED WARRANTY SHALL NOT EXCEED THE ACTUAL PURCHASE PRICE PAID FOR THE PRODUCT. TO THE MAXIMUM EXTENT PERMITTED BY LAW, KRAMER ELECTRONICS IS NOT RESPONSIBLE FOR DIRECT, SPECIAL, INCIDENTAL OR CONSEQUENTIAL DAMAGES RESULTING FROM ANY BREACH OF WARRANTY OR CONDITION, OR UNDER ANY OTHER LEGAL THEORY. Some countries, districts or states do not allow the exclusion or limitation of relief, special, incidental, consequential or indirect damages, or the limitation of liability to specified amounts, so the above limitations or exclusions may not apply to you.

Exclusive Remedy

TO THE MAXIMUM EXTENT PERMITTED BY LAW, THIS LIMITED WARRANTY AND THE REMEDIES SET FORTH ABOVE ARE EXCLUSIVE AND IN LIEU OF ALL OTHER WARRANTIES, REMEDIES AND CONDITIONS, WHETHER ORAL OR WRITTEN, EXPRESS OR IMPLIED. TO THE MAXIMUM EXTENT PERMITTED BY LAW, KRAMER ELECTRONICS SPECIFICALLY DISCLAIMS ANY AND ALL IMPLIED WARRANTIES, INCLUDING, WITHOUT LIMITATION, WARRANTIES OF MERCHANTABILITY AND FITNESS FOR A PARTICULAR PURPOSE. IF KRAMER ELECTRONICS CANNOT LAWFULLY DISCLAIM OR EXCLUDE IMPLIED WARRANTIES UNDER APPLICABLE LAW, THEN ALL IMPLIED WARRANTIES COVERING THIS PRODUCT, INCLUDING WARRANTIES OF MERCHANTABILITY AND FITNESS FOR A PARTICULAR PURPOSE, SHALL APPLY TO THIS PRODUCT AS PROVIDED UNDER APPLICABLE LAW.

IF ANY PRODUCT TO WHICH THIS LIMITED WARRANTY APPLIES IS A "CONSUMER PRODUCT" UNDER THE MAGNUSON-MOSS WARRANTY ACT (15 U.S.C.A. §2301, ET SEQ.) OR OTHER APPLICABLE LAW, THE FOREGOING DISCLAIMER OF IMPLIED WARRANTIES SHALL NOT APPLY TO YOU, AND ALL IMPLIED WARRANTIES ON THIS PRODUCT, INCLUDING WARRANTIES OF MERCHANTABILITY AND FITNESS FOR THE PARTICULAR PURPOSE, SHALL APPLY AS PROVIDED UNDER APPLICABLE LAW.

Other Conditions

This limited warranty gives you specific legal rights, and you may have other rights which vary from country to country or state to state.

This limited warranty is void if (i) the label bearing the serial number of this product has been removed or defaced, (ii) the product is not distributed by Kramer Electronics or (iii) this product is not purchased from an authorized Kramer Electronics reseller. If you are unsure whether a reseller is an authorized Kramer Electronics reseller, please visit our Web site at www.kramerelectronics.com or contact a Kramer Electronics office from the list at the end of this document.

Your rights under this limited warranty are not diminished if you do not complete and return the product registration form or complete and submit the online product registration form. Kramer Electronics thanks you for purchasing a Kramer Electronics product. We hope it will give you years of satisfaction.

KRAMER



P/N: 2900-300490



Rev: 2



SAFETY WARNING

Disconnect the unit from the power supply before opening and servicing

For the latest information on our products and a list of Kramer distributors, visit our Web site where updates to this user manual may be found.

We welcome your questions, comments, and feedback.

www.kramerAV.com
info@kramerel.com