

**Kramer Electronics, Ltd.**

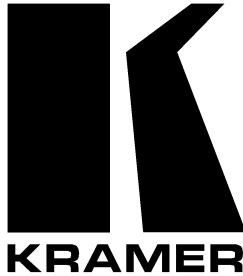

# **USER MANUAL**

**Model:**

**VP-214DS**

*4 Channel Automatic XGA Switcher*

## Contents

<b>1</b>	<b>Introduction</b>	<b>1</b>
<b>2</b>	<b>Getting Started</b>	<b>1</b>
<b>3</b>	<b>Overview</b>	<b>1</b>
<b>4</b>	<b>Your VP-214DS 4 Channel Automatic XGA Switcher</b>	<b>2</b>
<b>5</b>	<b>Installing on a Rack</b>	<b>6</b>
5.1	Before Installing on a Rack	6
5.1.1	 CAUTION!!	6
5.2	Instructions for Rack-Mounting	6
<b>6</b>	<b>Connecting a VP-214DS 4 Channel Automatic XGA Switcher</b>	<b>7</b>
6.1	Connecting a Single Unit or Several VP-214DS Machines	7
6.2	Controlling via RS-232 (for example, using a PC)	9
6.3	Controlling via RS-485	9
6.4	Controlling via ETHERNET	10
6.4.1	Connecting the ETHERNET port via a Crossover Cable	10
6.4.2	Connecting the ETHERNET via a Straight-Through Cable	12
6.5	Setting the Dipswitches	12
6.5.1	MACH. NO. (Machine Number) Dipswitches Setup	13
6.6	Connecting Several VP-214DS Machines	14
6.7	Control Configuration via the Ethernet Port	15
6.8	Resetting the Unit	15
<b>7</b>	<b>Operating the VP-214DS</b>	<b>16</b>
7.1	Selecting the Master Source Signal	16
7.2	Connecting the REMOTE Connector	18
<b>8</b>	<b>Firmware Upgrading</b>	<b>19</b>
8.1	Downloading from the Internet	19
8.2	Connecting the PC to the RS-232 Port	19
8.3	Upgrading Firmware	19
<b>9</b>	<b>Technical Specifications</b>	<b>24</b>
<b>10</b>	<b>Table of Hex Codes for Serial Communication</b>	<b>24</b>
10.1	Hex Codes for Assigning the Master Status	24
10.2	Hex Codes for Request Status of a video Output	25
10.3	Hex Codes for Request whether a Valid Input is Detected	25
10.4	Hex Codes for Lock Front Panel	25
<b>11</b>	<b>Kramer Protocol 2000</b>	<b>26</b>

## Figures

Figure 1: VP-214DS 4 Channel Automatic XGA Switcher	3
Figure 2: VP-214DS Underside Panel	5
Figure 3: Connecting the VP-214DS	8
Figure 4: Connecting a PC without using a Null-modem Adapter	9
Figure 5: RJ-45 PINOUT	10
Figure 6: Local Area Connection Properties Window	11
Figure 7: Internet Protocol (TCP/IP) Properties Window	11
Figure 8: VP-214DS Dipswitches	12
Figure 9: Connecting Several VP-214DS Machines	15
Figure 10: Remote Terminal Block Connector	18
Figure 11: Splash Screen	20
Figure 12: Atmel – Flip Window	20
Figure 13: Device Selection Window	20
Figure 14: Selecting the Device from the Selection Window	21
Figure 15: Loading the Hex	21
Figure 16: RS-232 Window	22
Figure 17: Atmel – Flip Window (Connected)	22
Figure 18: Atmel – Flip Window (Operation Completed)	23

## Tables

Table 1: Front Panel VP-214DS 4 Channel Automatic XGA Switcher Features	4
Table 2: Rear Panel VP-214DS 4 Channel Automatic XGA Switcher Features	4
Table 3: VP-214DS Underside Panel Features	5
Table 4: Recommended Ambient Temperature and Humidity Range	6
Table 5: Crossover Cable RJ-45 PINOUT	10
Table 6: Straight-through Cable RJ-45 PINOUT	12
Table 7: Dipswitch Settings	12
Table 8: MACH. NO. Dipswitch Settings	13
Table 9: Input Button Indications	16
Table 10: Input Button Functionality	17
Table 11: Technical Specifications of the VP-214DS	24
Table 12: VP-214DS Hex Codes for Assign of Master Status	24
Table 13: VP-214DS Hex Codes for Request Status of a Video Output	25
Table 14: VP-214DS Hex Codes for Requesting Detection of Valid Input	25
Table 15: Protocol Definitions	26
Table 16: Instruction Codes for Protocol 2000	27

## 1 Introduction

Welcome to Kramer Electronics (since 1981): a world of unique, creative and affordable solutions to the infinite range of problems that confront the video, audio and presentation professional on a daily basis. In recent years, we have redesigned and upgraded most of our line, making the best even better! Our 350-plus different models now appear in 8 Groups<sup>1</sup>, which are clearly defined by function.

Congratulations on purchasing your Kramer **VP-214DS 4 Channel Automatic XGA Switcher**, which is ideal for any system requiring multi-channel automatic computer and presentation XGA routing.

The package includes the following items:

- **VP-214DS 4 Channel Automatic XGA Switcher**
- Power cord and Null-modem adapter
- Windows®-based Configuration Manager, XPort software and Com Port Redirector
- Windows®-based Kramer control software
- This user manual<sup>2</sup>

## 2 Getting Started

We recommend that you:

- Unpack the equipment carefully and save the original box and packaging materials for possible future shipment
- Review the contents of this user manual
- Use Kramer high performance high resolution cables<sup>3</sup>

## 3 Overview

The high performance **VP-214DS 4 Channel Automatic XGA Switcher** is a high performance 2x1 4-channel automatic switcher for computer graphics signals. The **VP-214DS** detects the presence of the active XGA-type input signal, and automatically switches to the active input. If signals are present on

---

1 GROUP 1: Distribution Amplifiers; GROUP 2: Video and Audio Switchers, Matrix Switchers and Controllers; GROUP 3: Video, Audio, VGA/XGA Processors; GROUP 4: Interfaces and Sync Processors; GROUP 5: Twisted Pair Interfaces; GROUP 6: Accessories and Rack Adapters; GROUP 7: Scan Converters and Scalers; and GROUP 8: Cables and Connectors

2 Download up-to-date Kramer user manuals from our Web site at <http://www.kramerelectronics.com>

3 The complete list of Kramer cables is on our Web site at <http://www.kramerelectronics.com>

both inputs, by default, the master source signal is selected<sup>1</sup>.

In addition, the **VP-214DS**:

- Has a video bandwidth of 300MHz, to ensure transparent operation at the highest resolutions
- Includes 4 automatic 2x1 switchers
- Features automatic input signal detection
- Includes ID BIT control<sup>2</sup> for each channel
- Includes a looping XGA input with a loop termination switch
- Includes remote control contact closure
- Has a PANEL LOCK button for locking the front panel to prevent unintentional operation

Control the **VP-214DS** using the front panel buttons, or remotely via:

- RS-485 or RS-232 serial commands transmitted by a touch screen system, PC, or other serial controller
- Ethernet
- Remote control contact closure

The **VP-214DS** is dependable, rugged and fits into one vertical space (1U) of a standard 19" rack.

To achieve the best performance:

- Connect only good quality connection cables, thus avoiding interference, deterioration in signal quality due to poor matching, and elevated noise-levels (often associated with low quality cables)
- Avoid interference from neighboring electrical appliances and position your Kramer **VP-214DS** away from moisture, excessive sunlight and dust

## 4 Your VP-214DS 4 Channel Automatic XGA Switcher

Figure 1 illustrates the front and rear panels of the **VP-214DS**. Table 1 and Table 2 define the front and rear panels of the **VP-214DS**, respectively.

---

<sup>1</sup> You can select the master source signal via front panel buttons (IN 1 or IN 2 for each channel), or remotely via PC

<sup>2</sup> Sometimes notebook computers refuse to output a XGA signal to an external XGA monitor. By setting the ID BIT to ON, the notebook will output to an external XGA monitor

# Your VP-214DS 4 Channel Automatic XGA Switcher

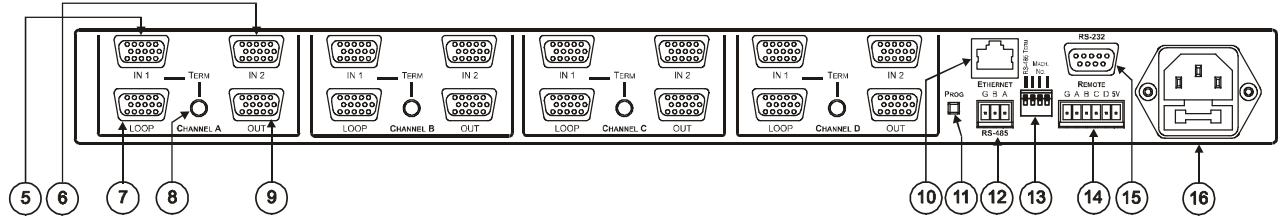
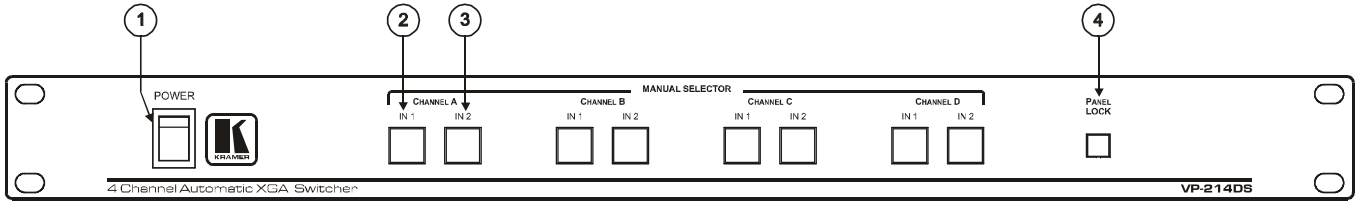

Figure 1: VP-214DS 4 Channel Automatic XGA Switcher

Table 1: Front Panel VP-214DS 4 Channel Automatic XGA Switcher Features

#	Feature	Function
1	POWER Switch	Illuminated switch supplying power to the unit
2	MANUAL SELECTOR CHANNEL A <sup>1</sup>	<b>IN 1 Button</b> Press to select input 1 as the Master Source signal (see section 7.1): The red LED illuminates when <i>IN 1</i> is the Master Source and the signal on the input is inactive The blue LED illuminates when <i>IN 1</i> is not the Master Source and the signal on the input is active Both the blue and red LEDs illuminate (creating purple) when <i>IN 1</i> is the Master Source and the signal on the input is active Button is not illuminated when <i>IN 1</i> is not the Master Signal and the signal is inactive
3		<b>IN 2 Button</b> Press to select input 2 as the Master Source signal (see section 7.1): The red LED illuminates when <i>IN 2</i> is the Master Source and the signal on the input is inactive The blue LED illuminates when <i>IN 2</i> is not the Master Source and the signal on the input is active Both the blue and red LEDs illuminate (creating purple) when <i>IN 2</i> is the Master Source and the signal on the input is active Button is not illuminated when <i>IN 2</i> is not the Master Signal and the signal is inactive
4	PANEL LOCK Button	Press to lock/unlock the front panel to prevent unintentional operation

Table 2: Rear Panel VP-214DS 4 Channel Automatic XGA Switcher Features

#	Feature	Function	
5	CHANNEL A <sup>1</sup>	HD15F IN 1 Connector	Connects to the <i>IN 1</i> XGA source
6		HD15F IN 2 Connector	Connects to the <i>IN 2</i> XGA source
7		HD15F LOOP Connector	Connects to a monitor looped to IN1
8		TERM Button	Release to terminate <i>IN 1</i> with 75Ω when connecting a monitor to the LOOP connector
9		HD15F OUT Connector	Connects to the output XGA acceptor
10	ETHERNET Connector	Connects to the PC or other controller through computer networking	
11	PROG Button	Push in to program for upgrading to the latest Kramer firmware (see section 8.2), or release for Normal (the factory default)	
12	RS-485 Connector	Use for bi-directional communication with another unit	
13	Setup Dipswitches	Set for machine setup (see section 6.5)	
14	REMOTE Terminal Block	Connects to a dry contact switch (see section 7.2)	
15	RS-232 DB 9F Connector	Connects to the PC or other Serial Controller	
16	Power Connector with Fuse	AC connector enabling power supply to the unit	

<sup>1</sup> For each of the four channels: A, B, C and D

Figure 2 illustrates the relevant underside of the **VP-214DS** unit and Table 3 defines the underside features.

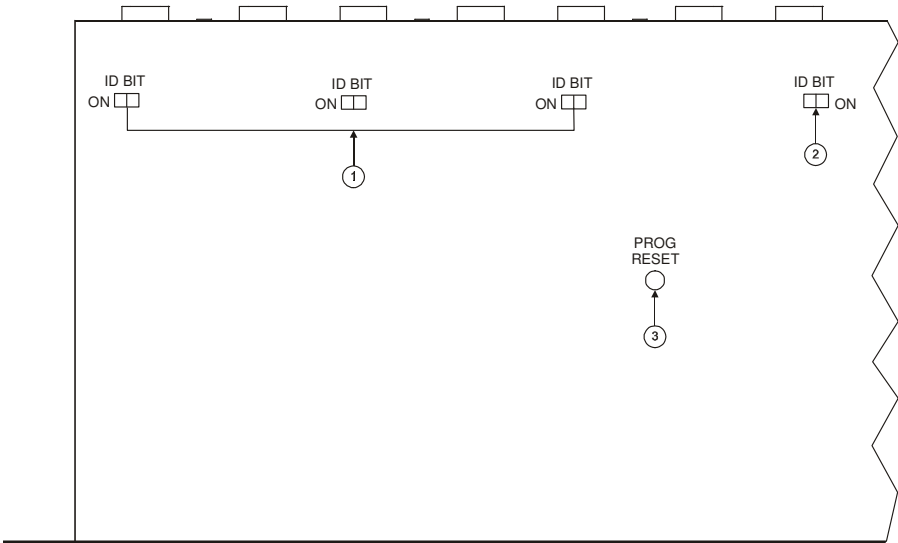

Figure 2: VP-214DS Underside Panel

Table 3: VP-214DS Underside Panel Features

#	Feature	Function
1	ID BIT Switches <sup>1</sup>	Slide switch to the left to set to ON <sup>2</sup> ; and to the right to set to OFF
2	ID BIT Switch <sup>3</sup>	Slide switch to the right to set to ON <sup>2</sup> and to the left to set to OFF
3	PROG RESET	Press to reset the unit prior to a firmware upgrade (see section 6.8)

1 For channels: A, B and C

2 Enabling the notebook to output an XGA signal to an external XGA monitor

3 For channel D

## 5 Installing on a Rack

This section describes what to do before installing on a rack (see section 5.1) and how to install on a rack (see section 5.2).

### 5.1 Before Installing on a Rack

Before installing the machine in a 19" rack, be sure that the environment is within the recommended range:

*Table 4: Recommended Ambient Temperature and Humidity Range*

Operating temperature range	+5 to +45 Deg. Centigrade
Operating humidity range	5 to 65 % RHL, non-condensing
Storage temperature range	-20 to +70 Deg. Centigrade
Storage humidity range	5 to 95% RHL, non-condensing

#### 5.1.1 CAUTION!!

When installing the **VP-214DS** in a 19" rack, avoid hazards by taking care that:

1. It is located within the recommended environmental conditions, as the operating ambient temperature of a closed or multi-unit rack assembly may exceed the room ambient temperature.
2. Once rack-mounted, enough air will still flow around the machine.
3. The machine is placed straight in the correct horizontal position.
4. You do not overload the circuit(s). When connecting the machine to the supply circuit, overloading the circuits might have a detrimental effect on overcurrent protection and supply wiring. Refer to the appropriate nameplate ratings for information. For example, for fuse replacement, see the value printed on the product label.
5. The machine is earthed (grounded) in a reliable way and is connected only to an electricity socket with grounding. Pay particular attention to supply connections other than direct connections to the branch circuit (for example, the use of power strips), and that you use only the power cord that is supplied with the machine.

### 5.2 Instructions for Rack-Mounting

To install the **VP-214DS** in a 19" rack, place the rack ears of the machine against the rack rails of the rack, and insert the proper rack screws through each of the four holes in the rack ears<sup>1</sup>.

<sup>1</sup> Always mount the machine in the rack before you attach any cables or connect the machine to the power. If you are using a Kramer rack adapter kit (for a machine that is not 19"), refer to the Rack Adapters user manual (download it at: <http://www.kramerelectronics.com>) for installation instructions

## 6 Connecting a VP-214DS 4 Channel Automatic XGA Switcher

This section describes how to:

- Connect the **VP-214DS** unit (see section 6.1)
- Connect the **VP-214DS** for control via RS-232 (see section 6.2), RS-485 (see section 6.3) and/or the Ethernet (see sections 6.4 and 6.7)
- Connect several **VP-214DS** machines (see section 6.6)
- Set the dipswitches (see section 6.5)
- Reset the unit (see section 6.8)

### 6.1 Connecting a Single Unit or Several VP-214DS Machines

To connect the **VP-214DS 4 Channel Automatic XGA Switcher**, connect the following to the rear panel (see Figure 3):

1. For each channel<sup>1</sup> (A, B, C and D):
  - Connect XGA sources to the IN 1 and IN 2 connectors (for example a computer or a laptop)
  - Connect the OUT connector to a computer graphics acceptor (for example, a monitor or a projector)
  - Connect an additional monitor to the LOOP connector if required<sup>2</sup>
2. Connect the power cord<sup>3</sup> (not shown in Figure 3)
3. Connect to a controlling device (optional – see sections 6.2, 6.3 and 6.4).
4. Connect the RS-485 port to additional units (optional – section 6.6).
5. Set the dipswitches (see section 6.5).

---

<sup>1</sup> You do not have to connect the inputs on all channels

<sup>2</sup> When connecting an additional monitor, press the channel's TERM button

<sup>3</sup> We recommend that you use only the power cord that is supplied with this machine

## Connecting a VP-214DS 4 Channel Automatic XGA Switcher

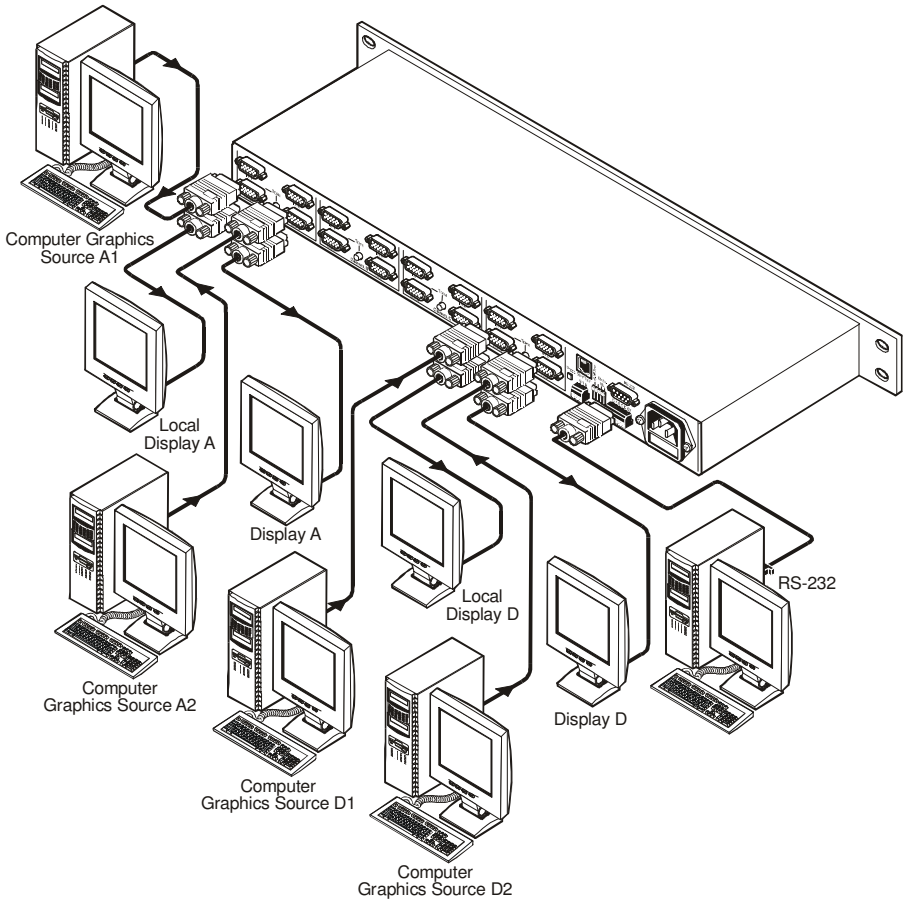

Figure 3: Connecting the VP-214DS



## 6.4 Controlling via ETHERNET

To control your **VP-214DS** via the Ethernet, connect the Ethernet port of the **VP-214DS** to the LAN port of your PC via a crossover cable (see section 6.4.1) or a straight through cable (see section 6.4.2)<sup>1</sup>.

### 6.4.1 Connecting the ETHERNET port via a Crossover Cable

Connect the Ethernet port of the **VP-214DS** to the LAN port on your PC, via a crossover cable with RJ-45 connectors, as Table 5 and Figure 5 define.

Figure 5: RJ-45 PINOUT

Table 5: Crossover Cable RJ-45 PINOUT

EIA /TIA 568A Side 1		EIA /TIA 568B Side 2	
PIN	Wire Color	PIN	Wire Color
1	White-orange	1	White-green
2	Orange	2	Green
3	White-green	3	White-orange
4	Blue	4	Blue
5	White-blue	5	White-blue
6	Green	6	Orange
7	White-brown	7	White-brown
8	Brown	8	Brown
Pair 1	4 and 5	Pair 1	4 and 5
Pair 2	1 and 2	Pair 2	3 and 6
Pair 3	3 and 6	Pair 3	1 and 2
Pair 4	7 and 8	Pair 4	7 and 8

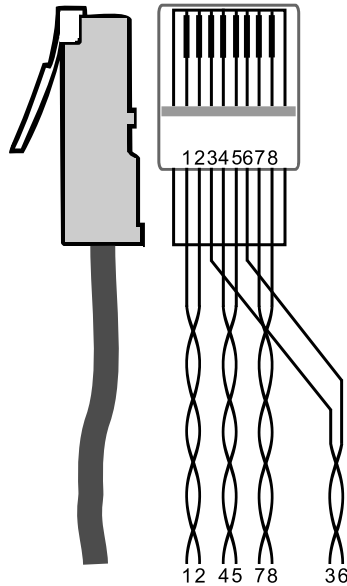

This type of connection is recommended for identification of the factory default IP Address of the **VP-214DS** during the initial configuration

After connecting the Ethernet port, configure your PC as follows:

1. Right-click the My Network Places icon on your desktop.
2. Select **Properties**.

<sup>1</sup> After connecting the Ethernet port, you have to install and configure your Ethernet Port and also install the COM Port Redirector. For detailed instructions, see the "Ethernet Configuration (Lantronix) guide.pdf" file in the technical support section on our Web site: <http://www.kramerelectronics.com>

3. Right-click Local Area Connection Properties.
4. Select **Properties**.  
The Local Area Connection Properties window appears.
5. Select the Internet Protocol (TCP/IP) and click the **Properties** Button (see Figure 6).

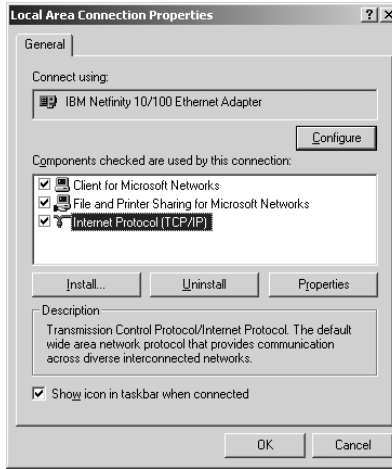

Figure 6: Local Area Connection Properties Window

6. Select Use the following IP Address, and fill in the details as shown in Figure 7.
7. Click **OK**.

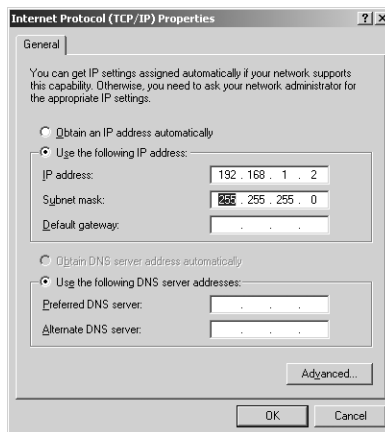

Figure 7: Internet Protocol (TCP/IP) Properties Window

## 6.4.2 Connecting the ETHERNET via a Straight-Through Cable

If connecting the Ethernet port of the **VP-214DS** to the LAN port on a network hub or network router, use a straight-through cable with RJ-45 connectors, as Table 6 defines:

Table 6: Straight-through Cable RJ-45 PINOUT

Side 1		Side 2	
PIN	Wire Color	PIN	Wire Color
1	White-orange	1	White-orange
2	Orange	2	Orange
3	White-green	3	White-green
4	Blue	4	Blue
5	White-blue	5	White-blue
6	Green	6	Green
7	White-brown	7	White-brown
8	Brown	8	Brown

## 6.5 Setting the Dipswitches

This section describes the machine set-up and dipswitch selection.

By default, all the **VP-214DS** dipswitches are set to OFF. Figure 8 and Table 7 describe the **VP-214DS** unit dipswitches.

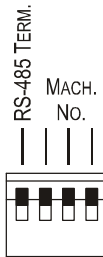

Figure 8: VP-214DS Dipswitches

Table 7: Dipswitch Settings

DIPS	Function	Description
1,	RS-485 TERM	ON for RS-485 Line Termination OFF for no RS-485 Line Termination
2, 3, 4	MACH. NO.	Determines the position of the machine in the sequence

### 6.5.1 MACH. NO. (Machine Number) Dipswitches Setup

The MACH. NO. dipswitches determine the position<sup>1</sup> of a **VP-214DS** machine, when several units connect to a PC or serial controller. Set the MACH. NO. dipswitches on each **VP-214DS** unit according to Table 8.

Determine the machine number of each connected unit according to the following guidelines:

- When connecting a single unit<sup>2</sup>, set the MACH. NO. dipswitches to 1
- When connecting other machines, set the MACH. NO. to subsequent numbers. For example, set the first unit that is closest to the PC as 1, set the second unit as 2, and so on
- If a remote controller is connected via RS-485 (see section 6.3), set the MACH. NO. on the first **VP-214DS** unit as 2, set the second unit as 3, and so on

*Table 8: MACH. NO. Dipswitch Settings*

MACH. NO.	DIPS		
	2	3	4
1	OFF	OFF	OFF
2	OFF	OFF	ON
3	OFF	ON	OFF
4	OFF	ON	ON
5	ON	OFF	OFF
6	ON	OFF	ON
7	ON	ON	OFF
8	ON	ON	ON

<sup>1</sup> For example, set the second unit to 2, the third unit to 3, and so on (see Figure 9); when operating a single unit, set MACH. NO. to 1 (the Master unit)

<sup>2</sup> Except if controlling via RS-485

## 6.6 Connecting Several VP-214DS Machines

For certain applications, you may need more than just 4 channels for switching. Cascading **VP-214DS** units enables you to expand the number of 2x1 switchers to be used.

You can cascade up to 8 individual **VP-214DS** units. For example, 3 **VP-214DS** units, connected via RS-232 and RS-485, will operate separately, forming 12 separate 2x1 XGA switchers.

To cascade up to 8 individual **VP-214DS** units (see Figure 9), do the following:

1. Connect the XGA sources and acceptors as section 6.1 describes.
2. Turn ON the power.
3. Connect the RS-232 port on the first **VP-214DS** unit to the PC using the Null-modem adapter provided with the machine (recommended), as section 6.2 describes<sup>1</sup>.
4. Connect the RS-485 terminal block port on the first **VP-214DS** unit to the RS-485 port on the second **VP-214DS** unit and so on, connecting all the RS-485 ports.
5. Set the Machine dipswitches as follows:
  - Set the first **VP-214DS** unit MACH. NO. dipswitches to Machine # 1 and the following units to Machine # 2, Machine # 3, and so on – up to the last connected **VP-214DS** unit (according to Table 8)
  - Set the RS-485 TERM dipswitch ON on the first (Master) and last **VP-214DS** unit (terminating the RS-485 line) and set it OFF on the remaining units

---

<sup>1</sup> Or connect via the Ethernet port as section 6.7 describes

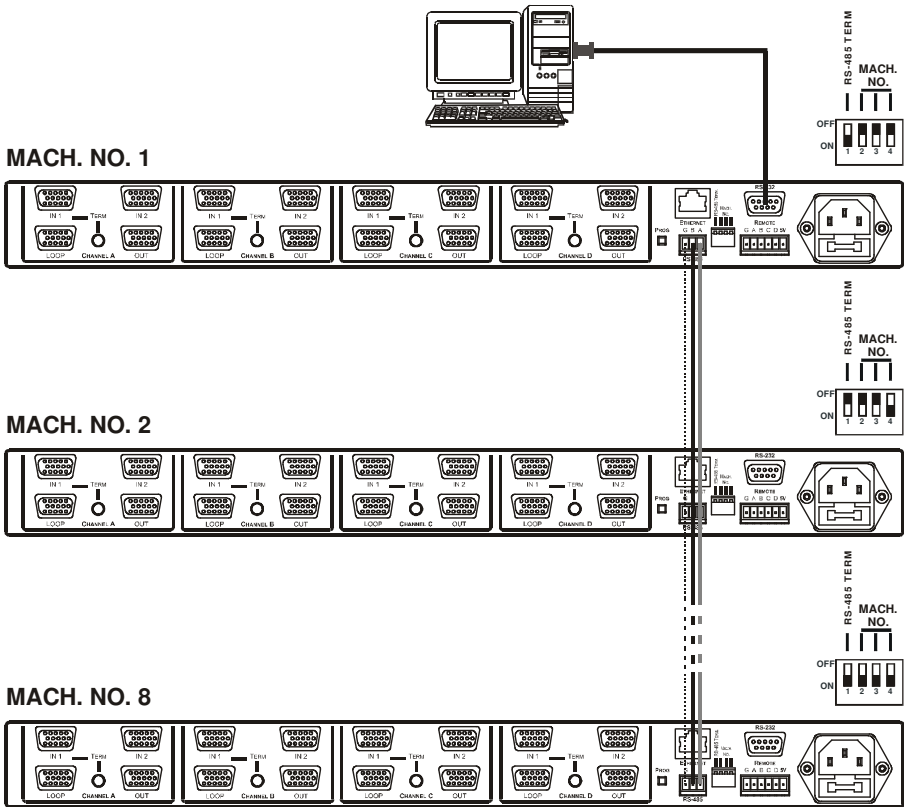

Figure 9: Connecting Several VP-214DS Machines

## 6.7 Control Configuration via the Ethernet Port

To control several units via the Ethernet, connect the Master unit (MACH NO. 1) via the Ethernet port to the LAN port of your PC. Use your PC initially to configure the settings (see section 6.4).

## 6.8 Resetting the Unit

Push the RESET button, located on the underside of the unit, only prior to upgrading to the latest Kramer firmware (see section 8.2).

## 7 Operating the VP-214DS

This section describes how to:

- Select the Master Source signal (see section 7.1)
- Connect the REMOTE connector (see section 7.2)

### 7.1 Selecting the Master Source Signal

Select the Master Source signal by pressing the appropriate input button<sup>1</sup>.

The **VP-214DS** automatically switches to the Master Source if it is connected to an active signal. If the Master Source signal is inactive, the machine automatically switches to the other input signal and once the Master Source signal becomes active, the machine automatically switches back.

The MANUAL SELECTOR IN button indications are summarized in Table 9:

*Table 9: Input Button Indications*

Input Button LED	Master Source	Signal
Red	Yes	No
Blue	No	Yes
Purple (Red +Blue)	Yes	Yes
Not illuminated	No	No

---

<sup>1</sup> Press the IN 1 button to select input 1 to be the Master Source signal; press the IN 2 button to select input 2 as the Master Source signal (for channels A, B, C, and D)

To understand how the input button LEDs function, consider the following examples<sup>1</sup>:

Table 10: Input Button Functionality

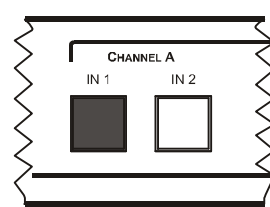
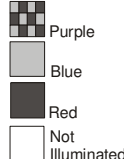
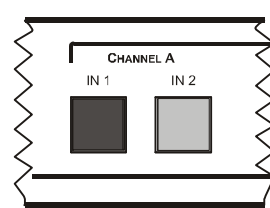
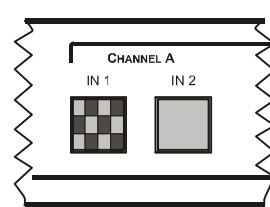
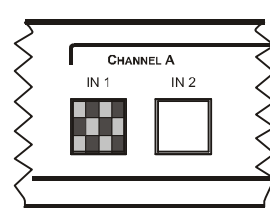
<ul style="list-style-type: none"> <li>➤ IN 1 is the Master Input</li> <li>➤ Input 1 is inactive</li> <li>➤ Input 2 is inactive</li> </ul>		
<ul style="list-style-type: none"> <li>➤ IN 1 is the Master Input</li> <li>➤ Input 1 is inactive</li> <li>➤ Input 2 is active</li> </ul> <p><b>IN 2 automatically takes priority over IN 1</b></p>		
<ul style="list-style-type: none"> <li>➤ IN 1 is the Master Input</li> <li>➤ Input 1 is active</li> <li>➤ Input 2 is active</li> </ul> <p><b>IN 1 automatically takes priority over IN 2</b></p>		
<ul style="list-style-type: none"> <li>➤ IN 1 is the Master Input</li> <li>➤ Input 1 is active</li> <li>➤ Input 2 is inactive</li> </ul> <p><b>VP-214DS Automatically switches to IN 1</b></p>		

<sup>1</sup> In this example, IN 1 is selected to be the Master Source but you can select IN 2 to be the Master Source by pressing the IN 2 button

## 7.2 Connecting the REMOTE Connector

You may reverse the presently routed connection by using the remote control contact closure<sup>1</sup>. To do so, connect the appropriate channel<sup>2</sup> pin on the REMOTE terminal block connector to the G (Ground) pin<sup>3</sup>, as Figure 10 illustrates. You can also connect several channels to G.

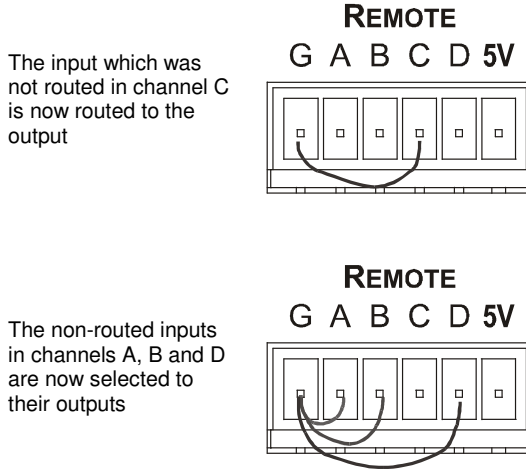

Figure 10: Remote Terminal Block Connector

<sup>1</sup> For example, if channel A inputs are set according to the second example in Table 10, input 1 will be routed to the output even if it does not have an active signal

<sup>2</sup> Channel A, B, C and/or D

<sup>3</sup> Note that the connection should be permanent, since the VP-214DS will revert to an automatic switcher when the connection is removed

## 8 Firmware Upgrading

The **VP-214DS** firmware is located in FLASH memory, which lets you upgrade to the latest Kramer firmware version in minutes! The process involves:

- Downloading from the Internet (see section 8.1)
- Connecting the PC to the RS-232 port (see section 8.2)
- Upgrading firmware (see section 8.3)

### 8.1 Downloading from the Internet

You can download the up-to-date file from the Internet. To do so:

1. Go to our Web site at <http://www.kramerelectronics.com> and download the appropriate file<sup>1</sup> from the Technical Support section.
2. Extract the downloaded file to a folder (for example, C:\Program Files\Kramer Flash).
3. Create a shortcut on your desktop to the file: “*FLIP.EXE*”.

### 8.2 Connecting the PC to the RS-232 Port

Before installing the latest Kramer firmware version on a **VP-214DS** unit, do the following:

1. Connect the RS-232 DB9 rear panel port on the **VP-214DS** unit to the Null-modem adapter and connect the Null-modem adapter with a 9-wire flat cable to the RS-232 DB9 COM port on your PC (see section 6.2).
2. Connect the power to the **VP-214DS** unit and switch it ON.
3. Push in the PROG button to the Program position.
4. On the underside panel push the reset button, using a screwdriver (see Figure 2).

### 8.3 Upgrading Firmware

Follow these steps to upgrade the firmware:

1. Double click the desktop icon: “*Shortcut to FLIP.EXE*”.  
The Splash screen appears as follows:

---

<sup>1</sup> For example, “*FLIP\_VP214DS.zip*”

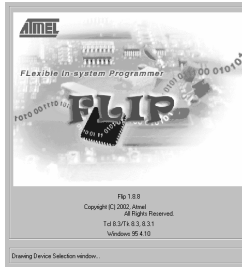

Figure 11: Splash Screen

2. After a few seconds, the Splash screen is replaced by the “Atmel – Flip” window:

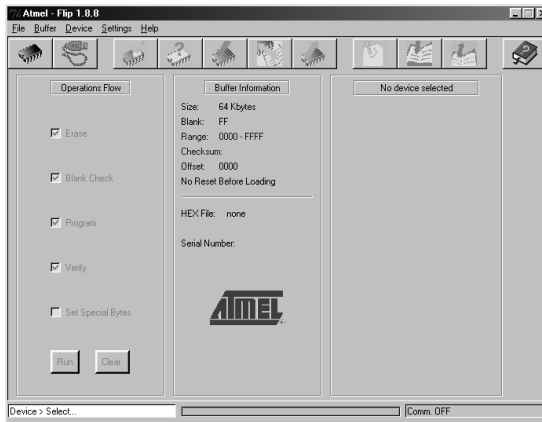

Figure 12: Atmel – Flip Window

3. Press the keyboard shortcut key F2 (or select the “Select” command from the Device menu, or press the integrated circuit icon in the upper right corner of the window).  
The “Device Selection” window appears:



Figure 13: Device Selection Window

- Click the button next to the name of the device and select from the list:  
AT89C51RD2:

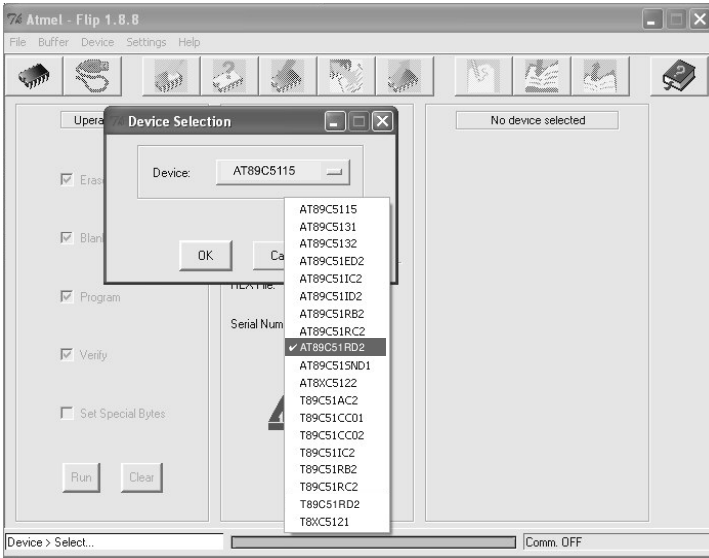

Figure 14: Selecting the Device from the Selection Window

- Click OK and select “Load Hex” from the File menu.

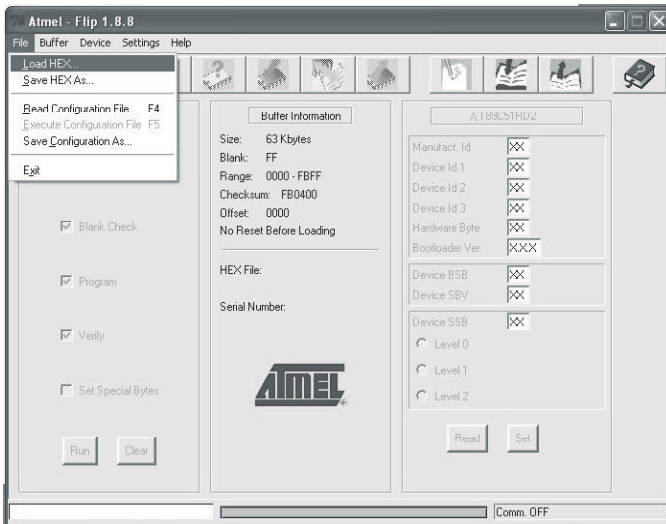

Figure 15: Loading the Hex

6. The Open File window opens. Select the correct HEX file that contains the updated version of the firmware for **VP-214DS** (for example, 214DSM\_V1p2.hex) and click Open.
7. Press the keyboard shortcut key F3 (or select the “Communication / RS232” command from the Settings menu, or press the keys: Alt SCR). The “RS232” window appears. Change the COM port according to the configuration of your computer and select the 9600 baud rate:

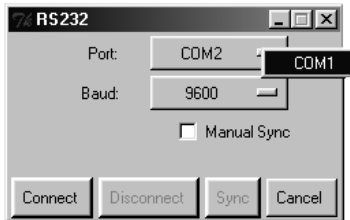

Figure 16: RS-232 Window

8. Click Connect.  
In the “Atmel – Flip” window, in the Operations Flow column, the Run button is active, and the name of the chip appears as the name of the third column: AT89C51RD2.  
Verify that in the *Buffer Information* column, the appropriate HEX File appears<sup>1</sup>.

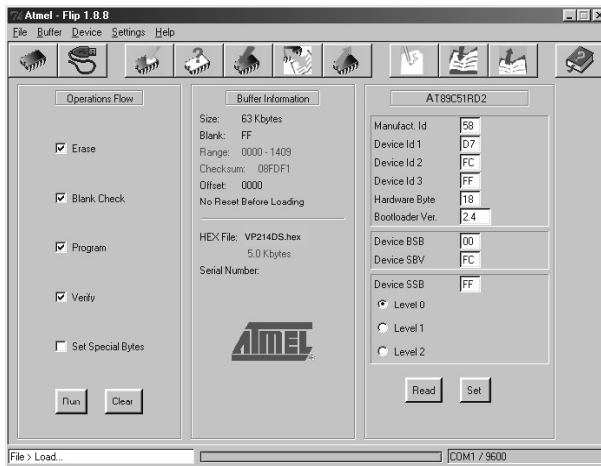

Figure 17: Atmel – Flip Window (Connected)

<sup>1</sup> For example, “VP214DS.hex”

9. Click *Run*.

Upon completion of each stage of the operation, the check-box for that stage turns green<sup>1</sup>.

When the operation is completed, all 4 check-boxes will be colored green and the status bar message: *Memory Verify Pass* appears<sup>2</sup>:

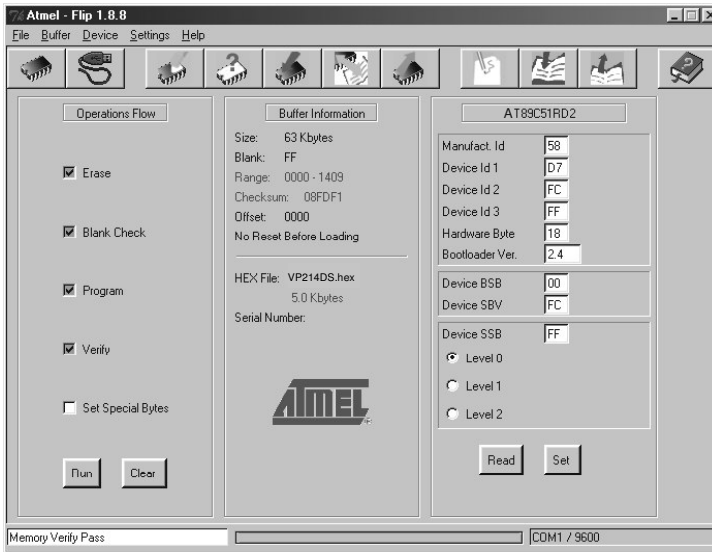

Figure 18: Atmel – Flip Window (Operation Completed)

10. Close the “Atmel – Flip” window.

11. Disconnect the power on the **VP-214DS**.

12. If required, disconnect the RS-232 rear panel port on the **VP-214DS** unit from the Null-modem adapter.

13. Connect the power on the **VP-214DS**.

<sup>1</sup> See also the blue progress indicator on the status bar

<sup>2</sup> If an error message: “Not Finished” shows, click Run again

## 9 Technical Specifications

Table 11 includes the technical specifications.

*Table 11: Technical Specifications<sup>1</sup> of the VP-214DS*

INPUTS:	4 x (2 XGA + loop) on HD15F connectors
OUTPUTS:	4 XGA on HD15F connectors
MAX. OUTPUT LEVEL:	1.5Vpp
BANDWIDTH (-3dB):	320MHz
DIFF. GAIN:	0.04%
DIFF. PHASE:	0.07 Deg.
K-FACTOR:	<0.05%
S/N RATIO:	73dB
CROSTALK (all hostile):	-57dB @ 5MHz, -42dB @ 100MHz
CONTROLS:	4 sets of 2 manual selector front panel touch switches, RS-232, RS-485, or Ethernet, termination at input, panel lock
POWER SOURCE:	230VAC, 50/60 Hz (115 VAC, USA) 4.6VA
DIMENSIONS:	19 inch (W), 7 inch (D), 1U (H) rack mountable
WEIGHT:	2.7 kg (6 lbs.) approx.
ACCESSORIES:	Power cord, Null modem adapter, Windows®-based control software, Windows®-based Configuration Manager XPort software and Com Port Redirector

## 10 Table of Hex Codes for Serial Communication

The following sections contain the tables of hex codes for assigning the master status, request status of a video output, request whether a valid input is detected and lock front panel respectively.

### 10.1 Hex Codes for Assigning the Master Status

Table 12 lists the Hex codes for assign of Master status.

*Table 12: VP-214DS Hex Codes for Assign of Master Status*

	Channel A (OUT 1)	Channel B (OUT 2)	Channel C (OUT 3)	Channel D (OUT 4)
<b>In 1</b>	01 81 81 81	01 81 82 81	01 81 83 81	01 81 84 81
<b>In 2</b>	01 82 81 81	01 82 82 81	01 82 83 81	01 82 84 81

<sup>1</sup> Specifications are subject to change without notice

## 10.2 Hex Codes for Request Status of a video Output

Table 13 Lists the Hex values for request status of a video output.

*Table 13: VP-214DS Hex Codes for Request Status of a Video Output*

Channel A (OUT 1)	Channel B (OUT 2)	Channel C (OUT 3)	Channel D (OUT 4)
05 80 81 81	05 80 82 81	05 80 83 81	05 80 84 81

Reply to the request is:

- 45 80 80 81, if IN 1 is selected as Master
- 45 80 81 81, if IN 2 is selected as Master

## 10.3 Hex Codes for Request whether a Valid Input is Detected

Table 14 lists the Hex values for request whether a valid input is detected:

*Table 14: VP-214DS Hex Codes for Requesting Detection of Valid Input<sup>1</sup>*

	Channel A (OUT 1)	Channel B (OUT 2)	Channel C (OUT 3)	Channel D (OUT 4)
<b>In 1</b>	0F 81 81 81	0F 83 81 81	0F 85 81 81	0F 87 81 81
<b>In 2</b>	0F 82 81 81	0F 84 81 81	0F 86 81 81	0F 88 81 81

Reply to the request for channel A, IN 1, is:

- 4F 81 80 81, if no valid input is detected
- 4F 81 81 81, if a valid input is detected

Reply to the request for channel C, IN 2, is:

- 4F 81 80 81, if no valid input is detected
- 4F 81 81 81, if a valid input is detected

## 10.4 Hex Codes for Lock Front Panel

Hex code for lock front panel:

1E 81 80 81

for unlock front panel:

1E 80 80 81

The Hex code for request whether panel is locked:

1F 80 80 81

Reply is:

1F 80 80 81

if panel is unlocked

Reply is:

1F 80 81 81

if panel is locked

<sup>1</sup> The valid input is an input, in which the signal is present (is detected)

## 11 Kramer Protocol 2000

The **VP-214DS** is compatible with Kramer’s Protocol 2000 (version 0.46) (below). This RS-232/RS-485 communication protocol uses four bytes of information as defined below.

For RS-232, a null-modem connection between the machine and controller is used. The default data rate is 9600 baud, with no parity, 8 data bits and 1 stop bit.

*Table 15: Protocol Definitions*

	MSB							LSB
	DESTINATION	INSTRUCTION						
0	D	N5	N4	N3	N2	N1	N0	
7	6	5	4	3	2	1	0	
1st byte								
	INPUT							
1	I6	I5	I4	I3	I2	I1	I0	
7	6	5	4	3	2	1	0	
2nd byte								
	OUTPUT							
1	O6	O5	O4	O3	O2	O1	O0	
7	6	5	4	3	2	1	0	
3rd byte								
	MACHINE NUMBER							
1	OVR	X	M4	M3	M2	M1	M0	
7	6	5	4	3	2	1	0	
4th byte								

1<sup>st</sup> BYTE: Bit 7 – Defined as 0.

D – “DESTINATION”: 0 - for sending information to the switchers (from the PC);

1 - for sending to the PC (from the switcher).

N5...N0 – “INSTRUCTION”

The function that is to be performed by the switcher(s) is defined by the INSTRUCTION (6 bits). Similarly, if a function is performed via the machine’s keyboard, then these bits are set with the INSTRUCTION NO., which was performed. The instruction codes are defined according to the table below (INSTRUCTION NO. is the value to be set for N5...N0).

2<sup>nd</sup> BYTE: Bit 7 – Defined as 1.

I6...I0 – “INPUT”.

When switching (ie. instruction codes 1 and 2), the INPUT (7 bits) is set as the input number which is to be switched. Similarly, if switching is done via the machine’s front-panel, then these bits are set with the INPUT NUMBER which was switched. For other operations, these bits are defined according to the table.

3<sup>rd</sup> BYTE: Bit 7 – Defined as 1.

O6...O0 – “OUTPUT”.

When switching (ie. instruction codes 1 and 2), the OUTPUT (7 bits) is set as the output number which is to be switched. Similarly, if switching is done via the machine’s front-panel, then these bits are set with the OUTPUT NUMBER which was switched. For other operations, these bits are defined according to the table.

4<sup>th</sup> BYTE: Bit 7 – Defined as 1.

Bit 5 – Don’t care.

OVR – Machine number override.

M4...M0 – MACHINE NUMBER.

Used to address machines in a system via their machine numbers. When several machines are controlled from a single serial port, they are usually configured together with each machine having an individual machine number. If the OVR bit is set, then all machine numbers will accept (implement) the command, and the addressed machine will reply.

For a single machine controlled via the serial port, always set M4...M0 = 1, and make sure that the machine itself is configured as MACHINE NUMBER = 1.

Table 16: Instruction Codes for Protocol 2000

Note: All values in the table are decimal, unless otherwise stated.

INSTRUCTION		DEFINITION FOR SPECIFIC INSTRUCTION		NOTE
#	DESCRIPTION	INPUT	OUTPUT	
0	RESET VIDEO	0	0	1
1	SWITCH VIDEO	Set equal to video input which is to be switched (0 = disconnect)	Set equal to video output which is to be switched (0 = to all the outputs)	2, 15
2	SWITCH AUDIO	Set equal to audio input which is to be switched (0 = disconnect)	Set equal to audio output which is to be switched (0 = to all the outputs)	2
3	STORE VIDEO STATUS	Set as SETUP #	0 - to store 1 - to delete	2, 3, 15
4	RECALL VIDEO STATUS	Set as SETUP #	0	2, 3, 15
5	REQUEST STATUS OF A VIDEO OUTPUT	Set as SETUP #	Equal to output number whose status is reqd	4, 3
6	REQUEST STATUS OF AN AUDIO OUTPUT	Set as SETUP #	Equal to output number whose status is reqd	4, 3
7	VIS SOURCE	Set as input # when OUTPUT byte = 6; OR set as output # when OUTPUT byte = 7; OR set as blank period (in steps of 25ms) when OUTPUT byte = 32; OR set = 0. ****	0 - No VIS (immediate) 1 - Input # 1 2 - External digital sync 3 - External analog sync 4 - Dynamic sync 5 - Inter-machine sync 6 - Input # (INPUT byte) 7 - Output # (INPUT byte) 8 - User-defined sync 32 - RGBHV seamless switching 64 - Set for delayed switch 65 - Execute delayed switch 66 - Cancel delayed switch setting	2, 5, 17, 18
8	BREAKAWAY SETTING	0	0 - audio-follow-video 1 - audio breakaway	2
		1	0 - FOLLOW mode 1 - Normal mode	15
9	VIDEO / AUDIO TYPE SETTING	0 - for video	0 - CV                    4 - SDI 1 - YC                    5 - CV+YC 2 - YUV                  6 - VGA scaler 3 - RGBS                7 - DVI	2
		1 - for audio	O0=0 – Unbalanced audio O0=1 – Balanced audio O1=0 – Digital audio O1=1 – Analog audio O4=0, O3=0, O2=0-Mono O4=0, O3=0, O2=1-Stereo	
		2 - for VGA and DVI	1 - 640X480 2 - 800X600 3 - 1024X768	
10	REQUEST VIS SETTING	Set as SETUP #, or set to 126 or 127 to request if machine has this function	0 - VIS source 1 - Input # or output # of source 2 - Vertical sync freq (Hz)	3, 4, 6, 7
11	REQUEST BREAKAWAY SETTING	Set as SETUP #, or set to 126 or 127 to request if machine has this function	0 - Request audio breakaway setting 1 - Request "FOLLOW" setting	3, 4, 6, 15
12	REQUEST VIDEO / AUDIO TYPE SETTING	Set as SETUP #, or set to 126 or 127 to request if machine has this function	0 - for video 1 - for audio 2 - for VGA	3, 4, 6
13	SET HIGHEST MACHINE ADDRESS	0 - for video 1 - for audio	Set equal to highest machine address	2
14	REQUEST HIGHEST MACHINE ADDRESS	0 - for video 1 - for audio	0	4

INSTRUCTION		DEFINITION FOR SPECIFIC INSTRUCTION		NOTE
#	DESCRIPTION	INPUT	OUTPUT	
15	REQUEST WHETHER SETUP IS DEFINED / VALID INPUT IS DETECTED	SETUP # or Input #	0 - for checking if setup is defined 1 - for checking if input is valid	8
16	ERROR / BUSY	For invalid / valid input (i.e. OUTPUT byte = 4 or OUTPUT byte = 5), this byte is set as the input #	0 - error 1 - invalid instruction 2 - out of range 3 - machine busy 4 - invalid input 5 - valid input	9, 25
17	RESERVED	----	----	10
18	RESET AUDIO	0	0	1
19	STORE AUDIO STATUS	Set as SETUP #	0 - to store 1 - to delete	2, 3
20	RECALL AUDIO STATUS	Set as SETUP #	0	2, 3
21	SET VIDEO PARAMETER	Equal to input / output number whose video parameter is to be set (0 = all)	Set as parameter value	2, 11, 24
22	SET AUDIO PARAMETER	Equal to input / output number whose gain is to be set (0 = all)	Set as parameter value	2, 11, 24
23	INCREASE / DECREASE VIDEO PARAMETER	Equal to input / output number whose video parameter is to be increased / decreased (0 = all)	0 - increase video gain 1 - decrease video gain 2 - increase contrast 3 - decrease contrast 4 - increase brightness 5 - decrease brightness 6 - increase colour 7 - decrease colour 8 - increase hue 9 - decrease hue 16 - increase H-phase 17 - decrease H-phase 18 - increase V-position 19 - decrease V-position	24
24	INCREASE / DECREASE AUDIO PARAMETER	Equal to input / output number whose parameter is to be increased / decreased (0 = all)	0 - increase output 1 - decrease output 2 - increase left output 3 - decrease left output 4 - increase right output 5 - decrease right output 6 - increase input 7 - decrease input 8 - increase left input 9 - decrease left input 10 - increase right input 11 - decrease right input	24
25	REQUEST AUDIO PARAMETER	Equal to input / output number whose parameter is requested	0	6, 24
26	REQUEST VIDEO PARAMETER	Equal to input / output number whose video parameter is requested	0	6, 24
30	LOCK FRONT PANEL	0 - Panel unlocked 1 - Panel locked	0	2
31	REQUEST WHETHER PANEL IS LOCKED	0	0	16
32 to 35	RESERVED	----	----	10
40	DIRECT MEMORY SAVE	Memory address	Data	20

INSTRUCTION		DEFINITION FOR SPECIFIC INSTRUCTION		NOTE
#	DESCRIPTION	INPUT	OUTPUT	
42	AUDIO PARAMETER SETTINGS FOR INSTRUCTIONS 22, 24, 25	INPUT Bit: 10 - 0=input; 1=output 11 - Left 12 - Right	0 - Gain 1 - Bass 2 - Treble 3 - Midrange	24
43	VIDEO PARAMETER SETTINGS FOR INSTRUCTIONS 21, 23, 26	1 - Input 2 - Output	0 - video gain 1 - contrast 2 - brightness 3 - colour 4 - hue 5 - H-phase 6 - V-position	24
56	CHANGE TO ASCII	0	1 - SVS protocol 2 - Generic protocol	19
57	SET AUTO-SAVE	13 - no save 14 - auto-save	0	12, 2
58	EXECUTE LOADED DATA	Set as 0, or as SETUP #.	1-Take 2-Cancel	22, 3
59	LOAD VIDEO DATA	Set equal to video input (0 = disconnect) ----- (127 = load SETUP #)	Set equal to video output (0 = to all the outputs) ----- or SETUP #	22, 23
60	LOAD AUDIO DATA	Set equal to audio input (0 = disconnect) ----- (127 = load SETUP #)	Set equal to audio output (0 = to all the outputs) ----- or SETUP #	22, 23
61	IDENTIFY MACHINE	1 - video machine name 2 - audio machine name 3 - video software version 4 - audio software version 5 - RS422 controller name 6 - RS422 controller version 7 - remote control name 8 - remote software version 9 - Protocol 2000 revision	0 - Request first 4 digits 1 - Request first suffix 2 - Request second suffix 3 - Request third suffix 10 - Request first prefix 11 - Request second prefix 12 - Request third prefix	13
62	DEFINE MACHINE	1 - number of inputs 2 - number of outputs 3 - number of setups	1 - for video 2 - for audio 3 - for SDI 4 - for remote panel 5 - for RS-422 controller	14
63	EXTENDED DATA	7 MSBs for INPUT data	7 MSBs for OUTPUT data	20

NOTES on the above table:

**NOTE 1** - When the master switcher is reset, (e.g. when it is turned on), the reset code is sent to the PC. If this code is sent to the switchers, it will reset according to the present power-down settings.

**NOTE 2** - These are bi-directional definitions. That is, if the switcher receives the code, it will perform the instruction; and if the instruction is performed (due to a keystroke operation on the front panel), then these codes are sent. For example, if the HEX code

01            85            88            83

was sent from the PC, then the switcher (machine 3) will switch input 5 to output 8. If the user switched input 1 to output 7 via the front panel keypad, then the switcher will send HEX codes:

41            81            87            83

to the PC.

When the PC sends one of the commands in this group to the switcher, then, if the instruction is valid, the switcher replies by sending to the PC the same four bytes that it was sent (except for the first byte, where the DESTINATION bit is set high).

**NOTE 3** - SETUP # 0 is the present setting. SETUP # 1 and higher are the settings saved in the switcher's memory, (i.e. those used for Store and Recall).

**NOTE 4** - The reply to a "REQUEST" instruction is as follows: the same instruction and INPUT codes as were sent are returned, and the OUTPUT is assigned the value of the requested parameter. The replies to instructions 10 and 11 are as per the definitions in instructions 7 and 8 respectively. For example, if the present status of machine number 5 is breakaway setting, then the reply to the HEX code

0B            80            80            85

would be HEX codes

4B            80            81            85

**NOTE 5** – For the OUTPUT byte set as 6, the VIS source is the input selected using the OUTPUT byte. Similarly, for the OUTPUT byte set as 7, the VIS source is the output selected using the OUTPUT byte. Note also, that on some machines the sync source is not software selectable, but is selected using switches, jumpers, etc!

**NOTE 6** – If INPUT is set to 127 for these instructions, then, if the function is defined on this machine, it replies with OUTPUT=1. If the function is not defined, then the machine replies with OUTPUT=0, or with an error (invalid instruction code).

If the INPUT is set to 126 for these instructions, then, if possible, the machine will return the current setting of this function, even for the case that the function is not defined. For example, for a video switcher which always switches during the VIS of input #1, (and its VIS setting cannot be programmed otherwise), the reply to the HEX code

0A FE 80 81 (ie. request VIS setting, with INPUT set as 126<sub>dec</sub>)

would be HEX codes

4A FE 81 81 (ie. VIS setting = 1, which is defined as VIS from input #1).

**NOTE 7** – Setting OUTPUT to 0 will return the VIS source setting as defined in instruction #7. Setting to 1 will return the input # or output # of the sync source (for the case where the VIS source is set as 6 or as 7 in instruction #7). Setting to 2 returns the vertical sync frequency (0 for no input sync, 50 for PAL, 60 for NTSC, 127 for error).

**NOTE 8** - The reply is as in TYPE 3 above, except that here the OUTPUT is assigned with the value 0 if the setup is not defined / no valid input is detected; or 1 if it is defined / valid input is detected.

**NOTE 9** - An error code is returned to the PC if an invalid instruction code was sent to the switcher, or if a parameter associated with the instruction is out of range (e.g. trying to save to a setup greater than the highest one, or trying to switch an input or output greater than the highest one defined). This code is also returned to the PC if an RS-232 instruction is sent while the machine is being programmed via the front panel. Reception of this code by the switcher is not valid.

**NOTE 10** – This code is reserved for internal use.

**NOTE 11** – For machines where the video and / or audio gain is programmable.

**NOTE 12** - Under normal conditions, the machine's present status is saved each time a change is made. The "power-down" save (auto-save) may be disabled using this code. Note that whenever the machine is turned on, the auto-save function is set.

**NOTE 13** - This is a request to identify the switcher/s in the system. If the OUTPUT is set as 0, and the INPUT is set as 1, 2, 5 or 7, the machine will send its name. The reply is the decimal value of the INPUT and OUTPUT. For example, for a 2216, the reply to the request to send the audio machine name would be (HEX codes):

7D 96 90 81 (i.e. 128<sub>dec</sub>+ 22<sub>dec</sub> for 2<sup>nd</sup> byte, and 128<sub>dec</sub>+ 16<sub>dec</sub> for 3<sup>rd</sup> byte).

If the request for identification is sent with the INPUT set as 3 or 4, the appropriate machine will send its software version number. Again, the reply would be the decimal value of the INPUT and OUTPUT - the INPUT representing the number in front of the decimal point, and the OUTPUT representing the number after it. For example, for version 3.5, the reply to the request to send the version number would be (HEX codes):

7D 83 85 81 (i.e. 128<sub>dec</sub>+ 3<sub>dec</sub> for 2<sup>nd</sup> byte, 128<sub>dec</sub>+ 5<sub>dec</sub> for 3<sup>rd</sup> byte).

If the OUTPUT is set as 1, then the ASCII coding of the lettering following the machine's name is sent. For example, for the VS-7588YC, the reply to the request to send the first suffix would be (HEX codes):

7D D9 C3 81 (i.e. 128<sub>dec</sub>+ ASCII for "Y"; 128<sub>dec</sub>+ ASCII for "C").

**NOTE 14** - The number of inputs and outputs refers to the specific machine which is being addressed, *not* to the system. For example, if six 16X16 matrices are configured to make a 48X32 system (48 inputs, 32 outputs), the reply to the HEX code

3E 82 81 82 (ie. request the number of outputs)

would be HEX codes

7E 82 90 82

ie. 16 outputs

**NOTE 15** – When the OVR bit (4<sup>th</sup> byte) is set, then the "video" commands have universal meaning. For example, instruction 1 (SWITCH VIDEO) will cause all units (including audio, data, etc.) to switch. Similarly, if a machine is in "FOLLOW" mode, it will perform any "video" instruction.

**NOTE 16** - The reply to the "REQUEST WHETHER PANEL IS LOCKED" is as in NOTE 4 above, except that here the OUTPUT is assigned with the value 0 if the panel is unlocked, or 1 if it is locked.

**NOTE 17** – For clean switching of RGBHV video, the "seamless switching" option may be used. The blanking period for the transition of the RGB sources may be set in this case, in steps of 25 milliseconds.

For example, to set for 350ms blanking time (14 steps), send HEX codes

07 8E A0 81

**NOTE 18** – Delayed execution allows switching after a delay dictated by RS-232. To do this, the user sends instruction 7 with the “Set for delayed switch” option (64<sub>dec</sub>) before sending the switch command (instruction 1) or pressing via front panel. The switch is not executed (unless timed-out) until the “Execute delayed switch” code is sent, or the “Set for delayed switch” code is sent again. (The mode is automatically cancelled after implementation of the switch if the “execute” command is used).

For example, to connect input 4 to output 3 after a delay, send HEX codes

07	80	C0	81	(set for delayed switch)
01	84	83	81	(switch code)

then, after the required delay, send HEX codes

07	80	C1	81	(execute delayed switch)
----	----	----	----	--------------------------

to implement the switch.

**NOTE 19** – After this instruction is sent, the unit will respond to the ASCII command set defined by the OUTPUT byte. The ASCII command to operate with the HEX command set must be sent in order to return to working with HEX codes.

**NOTE 20** – When data (ie. the INPUT and/or OUTPUT bytes) of more than 7 bits is required, this instruction is sent before sending the instruction needing the additional bits. The data in this instruction then becomes the Most Significant Bits of that next instruction. For example, to set the audio gain (instruction 22) of output 3 to 681<sub>dec</sub> (2A9<sub>hex</sub>), you would first send HEX codes

3F	80	85	81
----	----	----	----

and then send HEX codes

16	83	A9	81.
----	----	----	-----

To set the audio gain of output 6 to 10013<sub>dec</sub> (271D<sub>hex</sub>), first send HEX codes

3F	80	CE	81
----	----	----	----

followed by HEX codes

16	86	9D	81.
----	----	----	-----

**NOTE 21** – To store data in the non-volatile memory of the unit, eg. the EEPROM for saving SETUPS. The EEPROM address is sent using the INPUT byte, and the data to be stored is sent using the OUTPUT byte. To use this instruction, it is necessary to understand the memory map, and memory structure of the particular machine.

**NOTE 22** – Instruction 59 and instruction 60 load data for sending to the crosspoint switcher (or for storing in a SETUP), ie. the data is “lined-up” to be executed later. Instruction 58 executes the loaded data.

**NOTE 23** – If the INPUT byte is set as 127<sub>dec</sub>, then the data stored in a SETUP is loaded. The SETUP # is in the OUTPUT byte.

**NOTE 24** – Further information needed in instructions 21, 22, 25 and 26, is sent using instruction 42 – which is sent prior to the instruction. For example, to request the audio gain value of right input # 9, send hex codes

2A	84	80	81
----	----	----	----

and then send HEX codes

19	89	81	81.
----	----	----	-----

**NOTE 25** – For units which detect the validity of the video inputs, Instruction 16 will be sent whenever the unit detects a change in the state of an input (in real-time).

For example, if input 3 is detected as invalid, the unit will send the HEX codes

10	83	84	81
----	----	----	----

If input 7 is detected as valid, then the unit will send HEX codes

10	87	85	81.
----	----	----	-----

---

## LIMITED WARRANTY

Kramer Electronics (hereafter *Kramer*) warrants this product free from defects in material and workmanship under the following terms.

### HOW LONG IS THE WARRANTY

Labor and parts are warranted for three years from the date of the first customer purchase.

### WHO IS PROTECTED?

Only the first purchase customer may enforce this warranty.

### WHAT IS COVERED AND WHAT IS NOT COVERED

Except as below, this warranty covers all defects in material or workmanship in this product. The following are not covered by the warranty:

1. Any product which is not distributed by Kramer, or which is not purchased from an authorized Kramer dealer. If you are uncertain as to whether a dealer is authorized, please contact Kramer at one of the agents listed in the Web site [www.kramerelectronics.com](http://www.kramerelectronics.com).
2. Any product, on which the serial number has been defaced, modified or removed.
3. Damage, deterioration or malfunction resulting from:
  - i) Accident, misuse, abuse, neglect, fire, water, lightning or other acts of nature
  - ii) Product modification, or failure to follow instructions supplied with the product
  - iii) Repair or attempted repair by anyone not authorized by Kramer
  - iv) Any shipment of the product (claims must be presented to the carrier)
  - v) Removal or installation of the product
  - vi) Any other cause, which does not relate to a product defect
  - vii) Cartons, equipment enclosures, cables or accessories used in conjunction with the product

### WHAT WE WILL PAY FOR AND WHAT WE WILL NOT PAY FOR

We will pay labor and material expenses for covered items. We will not pay for the following:

1. Removal or installations charges.
2. Costs of initial technical adjustments (set-up), including adjustment of user controls or programming. These costs are the responsibility of the Kramer dealer from whom the product was purchased.
3. Shipping charges.

### HOW YOU CAN GET WARRANTY SERVICE

1. To obtain service on you product, you must take or ship it prepaid to any authorized Kramer service center.
2. Whenever warranty service is required, the original dated invoice (or a copy) must be presented as proof of warranty coverage, and should be included in any shipment of the product. Please also include in any mailing a contact name, company, address, and a description of the problem(s).
3. For the name of the nearest Kramer authorized service center, consult your authorized dealer.

### LIMITATION OF IMPLIED WARRANTIES

All implied warranties, including warranties of merchantability and fitness for a particular purpose, are limited in duration to the length of this warranty.

### EXCLUSION OF DAMAGES

The liability of Kramer for any effective products is limited to the repair or replacement of the product at our option. Kramer shall not be liable for:

1. Damage to other property caused by defects in this product, damages based upon inconvenience, loss of use of the product, loss of time, commercial loss; or:
2. Any other damages, whether incidental, consequential or otherwise. Some countries may not allow limitations on how long an implied warranty lasts and/or do not allow the exclusion or limitation of incidental or consequential damages, so the above limitations and exclusions may not apply to you.

This warranty gives you specific legal rights, and you may also have other rights, which vary from place to place.

**NOTE:** All products returned to Kramer for service must have prior approval. This may be obtained from your dealer. This equipment has been tested to determine compliance with the requirements of:

- EN-50081: "Electromagnetic compatibility (EMC);  
generic emission standard.  
Part 1: Residential, commercial and light industry"
- EN-50082: "Electromagnetic compatibility (EMC) generic immunity standard.  
Part 1: Residential, commercial and light industry environment".
- CFR-47: FCC Rules and Regulations:  
Part 15: "Radio frequency devices  
Subpart B – Unintentional radiators"

### CAUTION!

- ☒ Servicing the machines can only be done by an authorized Kramer technician. Any user who makes changes or modifications to the unit without the expressed approval of the manufacturer will void user authority to operate the equipment.
- ☒ Use the supplied DC power supply to feed power to the machine.
- ☒ Please use recommended interconnection cables to connect the machine to other components.



---

**For the latest information on our products and a list of Kramer distributors, visit our Web site: [www.kramerelectronics.com](http://www.kramerelectronics.com), where updates to this user manual may be found. We welcome your questions, comments and feedback.**



**Caution**

**Safety Warning:**

Disconnect the unit from the power supply before opening/servicing.



---

**Kramer Electronics, Ltd.**

Web site: [www.kramerelectronics.com](http://www.kramerelectronics.com)

E-mail: [info@kramerel.com](mailto:info@kramerel.com)

**P/N: 2900-00053 REV 1**