



KRAMER ELECTRONICS LTD.

# USER MANUAL

MODEL:

**VP-725NA**  
Presentation Switcher/Scaler

---

P/N: 2900-000739 Rev 4

# VP-725NA Quick Start Guide

This guide takes you through a basic installation and first-time use of your **VP-725NA**. For more detailed information, see the **VP-725NA** user manual. You can download the latest manual at <http://www.kramerelectronics.com>.

## Step 1: Check what's in the box

- The **725NA** Presentation Switcher Scaler
- 2 C-SF/2RVM cables
- IR remote control transmitter with batteries
- 1 Null-modem adapter
- 1 Set of rack ears
- 4 Rubber feet
- 1 Power cord
- 1 Quick start guide
- 1 User Manual

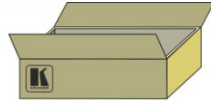

Save the original box and packaging materials in case your Kramer product needs to be returned to the factory for service.

## Step 2: Install the VP-725NA

Mount the machine in a rack or place on a table.

## Step 3: Connect inputs and outputs

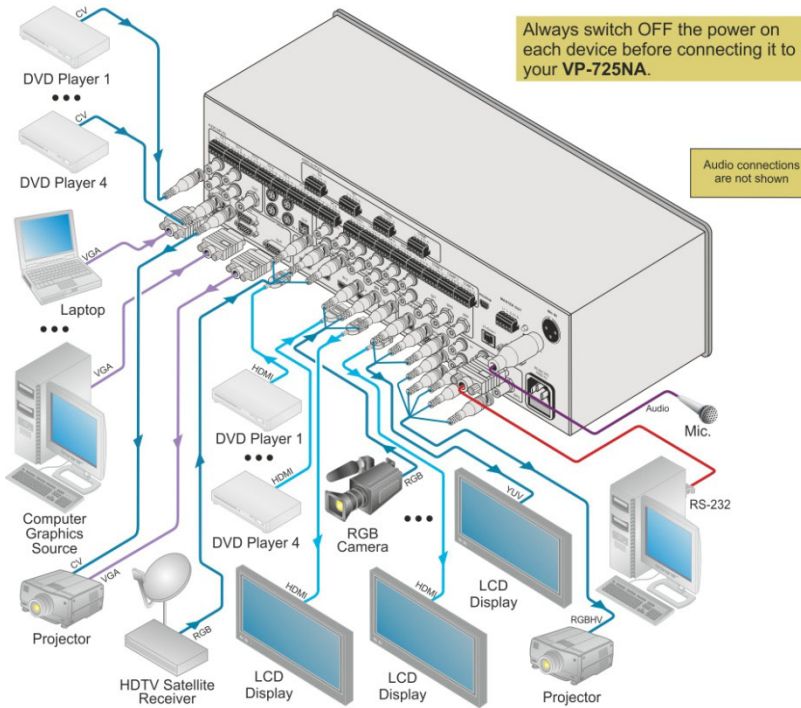

For best results, we recommend that you always use Kramer high-performance cables to connect AV equipment to the **VP-725NA**.

## Step 4: Connect the power

Connect AC power to the rear of the **VP-725NA**, switch on its power and then switch on the power on each device.

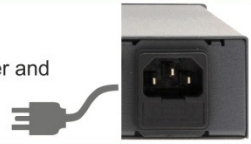

## Step 5: Operate via the front panel buttons and the remote control transmitter

Push the OSD button to access the menu and show the main menu screen on your display or projector.

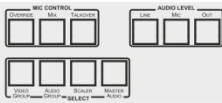

Select the microphone control mode. Select the Audio Level, using the VOL +/- buttons (below). Select the operation mode.

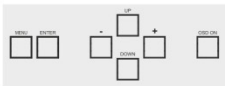

Press the MENU button to access the menu and show the main OSD menu. The arrow buttons and ENTER button let you navigate within the OSD menu. The VOL buttons set the audio level.

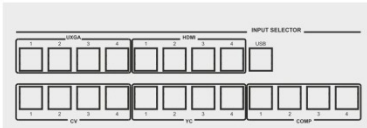

Press to select an input on each of the five independent 4x1 switchers. Press one of the 21 inputs to the scaled outputs.

If you cannot see any images, verify that the output cable to your display, TV, or projector is in good working order and is connected to the **VP-725NA**.

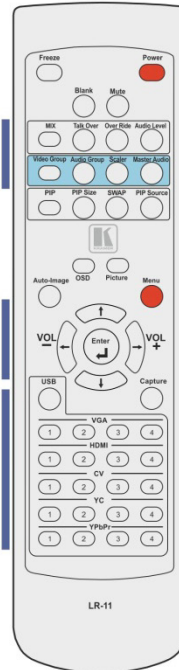

**POWER**  
Cycles power

## Step 6: Configure and operate the OSD menu



# Contents

<b>1</b>	<b>Introduction</b>	<b>1</b>
<b>2</b>	<b>Getting Started</b>	<b>2</b>
2.1	Achieving the Best Performance	2
<b>3</b>	<b>Overview</b>	<b>3</b>
3.1	Defining EDID	5
3.2	About HDMI	6
3.3	About HDCP	7
3.4	Defining the VP-725NA Presentation Switcher/Scaler	7
<b>4</b>	<b>Installing in a Rack</b>	<b>13</b>
<b>5</b>	<b>Connecting the VP-725NA Presentation Switcher/Scaler</b>	<b>14</b>
5.1	Connecting the VP-725NA	14
5.2	The RGBS and RGSB Pinouts	17
5.3	Connecting to the VP-725NA via RS-232	17
5.4	Connecting the VP-725NA via the ETHERNET port	18
5.5	Connecting the Balanced/Unbalanced Stereo Audio Input/Output	20
<b>6</b>	<b>Operating the VP-725NA Presentation Switcher/Scaler</b>	<b>21</b>
6.1	Using the Operating Modes	21
6.2	Switching an Input to an Output	23
6.3	Understanding the Audio Features	24
6.4	Understanding the PIP Feature	26
6.5	Locking and Unlocking the Front Panel	27
6.6	Freezing the Image	28
6.7	Displaying a Blank Screen	28
<b>7</b>	<b>Configuring and Controlling the VP-725NA</b>	<b>29</b>
7.1	Configuring the VP-725NA via the OSD MENU Screens	29
7.2	Operating via the LCD Display	46
7.3	Operating via ETHERNET/Serial Port	46
7.4	Operating via the Infrared Remote Control Transmitter	47
<b>8</b>	<b>Using Text Overlay</b>	<b>48</b>
<b>9</b>	<b>Technical Specifications</b>	<b>50</b>
<b>10</b>	<b>VP-725NA Communication Protocol</b>	<b>54</b>
10.1	Error Codes	66

# Figures

Figure 1: VP-725NA Presentation Switcher/Scaler Front Panel	8
Figure 2: VP-725NA Presentation Switcher/Scaler Rear Panel	11
Figure 3: Connecting to the VP-725NA Presentation Switcher/Scaler	16
Figure 4: Crossed Cable RS-232 Connection	17
Figure 5: Straight Cable RS-232 Connection with a Null Modem Adapter	18
Figure 6: Local Area Connection Properties Window	19
Figure 7: Internet Protocol (TCP/IP) Properties Window	19
Figure 8: Connecting a Balanced Stereo Audio Input/Output	20
Figure 9: Connecting an Unbalanced Stereo Audio Input	20
Figure 10: Connecting an Unbalanced Stereo Audio Output	20
Figure 11: Connecting an Unbalanced Stereo Audio Output	22
Figure 12: Adjusting the Audio Input and Audio Output Levels	25
Figure 13: MENU Items	29
Figure 14: Input Screen	30
Figure 15: Picture Screen	31
Figure 16: Output Screen	32
Figure 17: PIP Screen	35
Figure 18: Audio Screen	36
Figure 19: Audio Level Screen	37
Figure 20: Geometry Screen	38
Figure 21: Setup Screen	39
Figure 22: Advanced Setup Screen	41
Figure 23: Misc Setup Screen	42
Figure 24: Input Setup Screen	43
Figure 25: Output Setup Screen	44
Figure 26: Active Video Functions	45
Figure 27: Information Screen	45
Figure 28: Example of How to Use the LCD Display	46
Figure 29: Infrared Remote Control Transmitter	47
Figure 30: Text Overlay Application Screen	48

---

# 1 Introduction

Welcome to Kramer Electronics! Since 1981, Kramer Electronics has been providing a world of unique, creative, and affordable solutions to the vast range of problems that confront the video, audio, presentation, and broadcasting professional on a daily basis. In recent years, we have redesigned and upgraded most of our line, making the best even better!

Our 1,000-plus different models now appear in 11 groups that are clearly defined by function: GROUP 1: Distribution Amplifiers; GROUP 2: Switchers and Matrix Switchers; GROUP 3: Control Systems; GROUP 4: Format/Standards Converters; GROUP 5: Range Extenders and Repeaters; GROUP 6: Specialty AV Products; GROUP 7: Scan Converters and Scalers; GROUP 8: Cables and Connectors; GROUP 9: Room Connectivity; GROUP 10: Accessories and Rack Adapters and GROUP 11: Sierra Products.

Congratulations on purchasing your Kramer **VP-725NA** *Presentation Switcher/Scaler*, which is ideal for the following typical applications:

- Projection systems (with full audio capability) in conference rooms, board rooms, auditoriums, hotels, and churches
- Any application in which high quality conversion and switching of multiple and different video signals to graphical data is required for projection and large display purposes (with full audio capability)

---

## 2 Getting Started

We recommend that you:

- Unpack the equipment carefully and save the original box and packaging materials for possible future shipment
- Review the contents of this user manual
  - Use Kramer high performance high resolution cables
  - Use only the power cord that is supplied with this machine



Go to <http://www.kramerelectronics.com> to check for up-to-date user manuals, application programs, and to check if firmware upgrades are available (where appropriate).

### 2.1 Achieving the Best Performance

To achieve the best performance:

- Use only good quality connection cables to avoid interference, deterioration in signal quality due to poor matching, and elevated noise levels (often associated with low quality cables)
- Avoid interference from neighboring electrical appliances that may adversely influence signal quality
- Position your Kramer **VP-725NA** away from moisture, excessive sunlight and dust

---

## 3 Overview

The **VP-725NA** is a presentation scaler/switcher with multiple signal format sections and balanced stereo audio. The unit has five independent 4x1 video sections: composite, s-Video (Y/C), component (RGB), computer graphics, and HDMI, plus a single USB input. Each section can be operated as an individual switcher contained in one box. It also scales any of the 21 inputs up or down to a selectable graphics or HDTV output resolution and provides glitch-free switching between sources through FTB™ (fade-thru-black) switching technology.

In particular, the **VP-725NA** features include:

- Silicon Optix HQV® Video Processing (Hollywood Quality Video) which represents the state-of-the-art in video processing technology, with the highest quality de-interlacing, noise reduction, and scaling performance for both standard-definition and high-definition signals
- High-quality 3:2 and 2:2 pull down, de-interlacing and full up- and down-scaling of computer graphics video input signals  
Accommodates the frame-rate of a converted movie (24 frames per second) to video frequencies (25 frames per second (PAL); 30 frames per second (NTSC).
- HDTV Compatibility and HDCP compliance  
The HDCP (High Definition Content Protection) license agreement allows copy-protected data on the HDMI input to pass to the HDMI output only.
- Fade-Thru-Black (FTB™) Switching – The video fades to black and then the new input fades from black for smooth, glitch-free switching. The output signal provides constant sync so the display never glitches
- K-IIT XL™ Picture-in-Picture Image Insertion Technology –Ultra stable picture-in-picture, picture-and-picture, and split screen capability. Any video source can be inserted into or positioned next to a computer graphics video source or vice versa with window positioning and sizing controls (see [Section 6.4](#))
- Multi-Formats – Auto, NTSC (3.58/4.43), PAL (M/N/60) and SECAM
- Scaled computer & HDTV outputs – A single output signal in three formats (15-pin HD, RGBHV, and HDMI) simultaneously
- HDTV output resolutions – 720p, 1080i, and 1080p

- A USB port on the front panel for reading and displaying JPEG picture files
- Multiple color space – RGB or YUV output
- Embedded audio on the HDMI inputs and outputs  
The embedded audio feature is not available for the **RGB** resolutions 1920x1200 and 1920x1080. (It is available for 1080p)
- HDMI channel support of up to 2.25Gbps bandwidth per graphic channel  
Suitable for resolutions up to UXGA at 60Hz, and for all HD resolutions.
- Projector Anywhere™ technology – horizontal & vertical geometry controls that compensate for off-axis projector placement
- A wide choice of computer graphics output resolutions up to WUXGA/1080p, plus user-definable custom output resolutions with selectable refresh rates  
Recommended for advanced users only – non-standard settings may not be recognized by the display device.
- Multiple aspect ratio selections: standard, letterbox, follow output, virtual wide, follow input, and user definable settings
- Six possible operation modes via the Video Group, the Audio Group, the Scaler and the Master Audio buttons.  
These modes function simultaneously and independently, letting you switch the audio and video signals separately (breakaway mode) or in the audio-follow-video mode  
**VIDEO GROUP** – selects the video input from each group: CV, YC, COMP, UXGA, HDMI for switching to its local (group) output  
**AUDIO GROUP** – selects the audio input from each group for switching  
**SCALER MODE** – converts the selected input (one of 21) to the SCALED OUTPUTS  
**MASTER AUDIO MODE** - routes the selected audio input (one of 20) to the MASTER OUT terminal block connector
- An independent Master Audio output that has a rich set of ProcAmp features, including bass and treble controls (via the MENU, LCD status display, OSD, RS-232 and the infrared remote control transmitter)
- An adjustable volume on each input and output
- A microphone input that can be used by mixing, switching or talk-over
- Built-in ProcAmp: color, hue, sharpness, contrast, and brightness are set individually for each input
- A built-in time base corrector that stabilizes the sync in unstable video sources

- A built-in TBC (time base corrector) that stabilizes the sync in unstable video sources
- A slideshow feature, letting you run a slideshow via the USB port
- Front panel freeze frame
- Video blanking, with a selectable blue or black screen
- Screenshot capture

In addition, the **VP-725NA**:

- Scales and zooms (to up to 400% of the original size)
- Can be firmware upgraded in the field via the USB port on the front panel
- Includes worldwide power supply – 100-240V AC on a standard 19" rack mount size, 3U Rack "ears" included
- HDMI channel supports up to 2.25Gbps bandwidth per graphic channel  
Suitable for resolutions up to UXGA at 60Hz, and for all HD resolutions.

Control the **VP-725NA** from the front panel and a user-friendly menu-driven OSD (see [Section 7.1](#)), or:

- From the front panel high contrast LCD Display (see [Section 7.2](#))
- Via the Ethernet (see [Section 7.3](#))
- Remotely, from the infrared remote control transmitter (see [Section 7.4](#))
- Remotely, via RS-232 (see [Section 5.3](#))

### 3.1 Defining EDID

The Extended Display Identification Data (EDID) is a data-structure provided by a display, to describe its capabilities to a graphics card (that is connected to the display's source). The EDID enables the **VP-725NA** to "know" what kind of monitor is connected to the output. The EDID includes the manufacturer's name, the product type, the timing data supported by the display, the display size, luminance data and (for digital displays only) the pixel mapping data.

EDID is defined by a standard published by the Video Electronics Standards Association (VESA).

## 3.2 About HDMI

High-Definition Multimedia Interface (HDMI) is an uncompressed all-digital audio/video interface, widely supported in the entertainment and home cinema industry. HDMI ensures an all-digital rendering of video without the losses associated with analog interfaces and their unnecessary digital-to-analog conversions. It delivers the maximum high-definition image and sound quality in use today. Note that Kramer Electronics Limited is an HDMI Adopter and an HDCP Licensee.

HDMI, the HDMI logo and High-Definition Multimedia Interface are trademarks or registered trademarks of HDMI licensing LLC.

In particular, HDMI:

- Provides a simple interface between any audio/video source, such as a set-top box, DVD player, or A/V receiver and video monitor, such as a digital flat LCD / plasma television (DTV), over a single lengthy cable

**SIMPLICITY** - With video and multi-channel audio combined into a single cable, the cost, complexity, and confusion of multiple cables currently used in A/V systems is reduced

**LENGTHY CABLE** - HDMI technology has been designed to use standard copper cable construction at up to 15m
- Supports standard, enhanced, high-definition video, and multi-channel digital audio on a single cable

**MULTI-CHANNEL DIGITAL AUDIO** - HDMI supports multiple audio formats, from standard stereo to multi-channel surround-sound. HDMI has the capacity to support Dolby 5.1 audio and high-resolution audio formats
- Transmits all ATSC HDTV standards and supports 8-channel digital audio, with bandwidth to spare to accommodate future enhancements and requirements
- Benefits consumers by providing superior, uncompressed digital video quality via a single cable, and user-friendly connector

HDMI provides the quality and functionality of a digital interface while also supporting uncompressed video formats in a simple, cost-effective manner
- Is backward-compatible with DVI (Digital Visual Interface)
- Supports CEC, two-way communication between the video source (such as a DVD player) and the digital television, enabling new functionality such as automatic configuration and one-button play
- Has the capacity to support existing high-definition video formats (720p, 1080i, and 1080p, 2K and 4K), standard definition formats such as NTSC or PAL, as well as 480p and 576p

### 3.3 About HDCP

The High-Bandwidth Digital Content Protection (HDCP) standard developed by Intel, protects digital video and audio signals transmitted over DVI or HDMI connections between two HDCP-enabled devices to eliminate the reproduction of copyrighted material. To protect copyright holders (such as movie studios) from having their programs copied and shared, the HDCP standard provides for the secure and encrypted transmission of digital signals.

### 3.4 Defining the VP-725NA Presentation Switcher/Scaler

This section defines the **VP-725NA**.

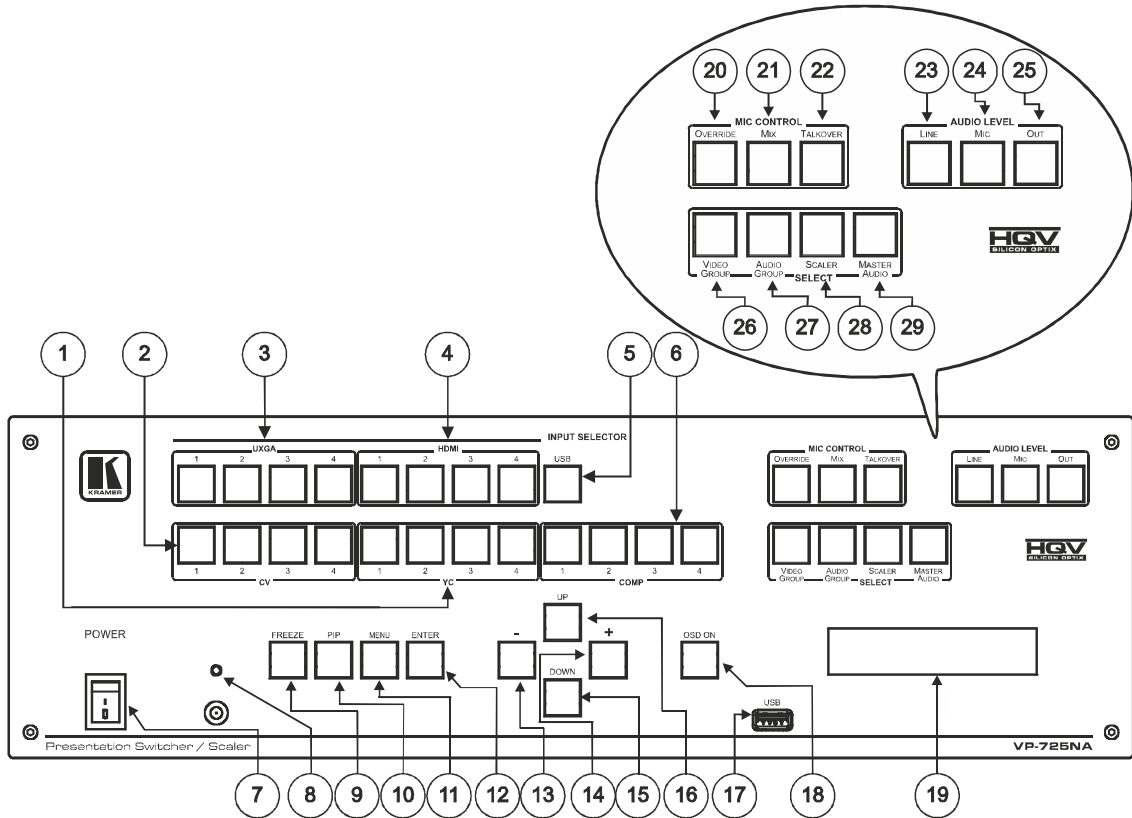

Figure 1: VP-725NA Presentation Switch/Scaler Front Panel

Front Panel		
#	Feature	Function
1	INPUT SELECT OR Buttons	YC
2		CV
3		UXGA
4		HDMI
5		USB
6		COMP
7	POWER Switch	Illuminated switch for turning the unit ON or OFF
8	IR Receiver/LED	Green when ON; red when OFF OFF in this case means that the outputs and the front-panel are disabled
9	FREEZE Button	Freezes the output video image Applicable to the Scaler outputs only
10	PIP Button	Selects the picture-in-picture function (see <a href="#">Section 6.4</a> )
11	MENU Button	Displays the OSD Menu screen (or returns to the previous level in the OSD screen)
12	ENTER Button	Moves to the next level in the OSD screen Press for about 3 seconds to lock/unlock the front panel buttons
13	- Button	Decreases the range by one step
14	+ Button	Increases the range by one step
15	DOWN Button	Moves down one step (in the same level) in the OSD screen
16	UP Button	Moves up one step (in the same level) in the OSD screen
17	USB Connector	Connect to a USB drive to read JPEG files
18	OSD ON Button	Activates/deactivates access to the OSD Menu  The OSD ON front panel button is activated (illuminated) by default, and pressing the MENU front panel button (or the MENU key on the infrared remote control transmitter (see <a href="#">Figure 29</a> )) displays the OSD Menu. To prevent OSD display, press the OSD ON front panel button (or the OSD key). The front panel button no longer illuminates, and the front panel LCD now operates independently of the OSD (when the OSD is OFF, the LCD is still operational)
19	LCD Status Display	Displays the status

Front Panel			
#	Feature		Function
20	MIC CONTROL Button	Override	Routes the signal from the microphone to the Master output instead of from the Line, whose signal is blocked  When no MIC CONTROL button is selected, the audio input is routed to the MASTER output, ignoring the Mic input
21		Mix	Routes the combined signals from the Mic and the Line to the Master output  Only one of the group buttons can be ON, or all buttons can be OFF (pressing a button will select that button, and turn OFF the previously selected button. If the selected button is pressed, it will turn it OFF)
22		Talkover	Routes the selected input to the output until an audio signal is detected on the microphone input. When this happens the selected input is faded out (to be faded back in when no input is detected on the microphone)
23	AUDIO LEVEL Button	Line	Press this button and adjust the audio level using the -/+ buttons (see <a href="#">Section 6.3.1</a> ). The level is displayed in the LCD Display and OSD
24		Mic	Only one of the group buttons can be ON, or all buttons can be OFF (pressing a button will select that button, and turn OFF the previously selected button. If the selected button is pressed, it will turn it OFF)
25		Out	Selecting OUT when the Audio Group button illuminates, lets you select the group (scrolling through CV, YC, VGA, Component and DVI, displaying the selection on the LCD (and OSD when appropriate) using the UP and DOWN buttons
26	SELECTButtons	Video Group	Select the Video Group operation mode; within each group, select which input (from 1 to 4) to switch to the output. The selected input button within each group is illuminated. If the AUDIO GROUP button is also illuminated, the audio follows the video  When selected, this button illuminates
27		Audio Group	Press to select the Audio Group mode: within each group, select the audio input (from 1 to 4) from each group for switching. If the VIDEO GROUP button is also illuminated, the audio follows the video  The VIDEO GROUP and AUDIO GROUP buttons set can be pressed simultaneously or independently; the SCALER and the MASTER OUTPUT buttons set can be pressed simultaneously or independently
28		Scaler	Select the Scaler mode: press an input button (1 of 21), to select the input to be scaled at the SCALED OUTPUTS. The selected input button illuminates. If the MASTER AUDIO button is also illuminated, the audio follows the video
29		Master Audio	Press to select the Master Audio mode: press an input button (1 of 20), to select the audio input to switch to the MASTER OUT terminal block connector. The selected input button illuminates. If the SCALER button is also illuminated, the audio follows the video

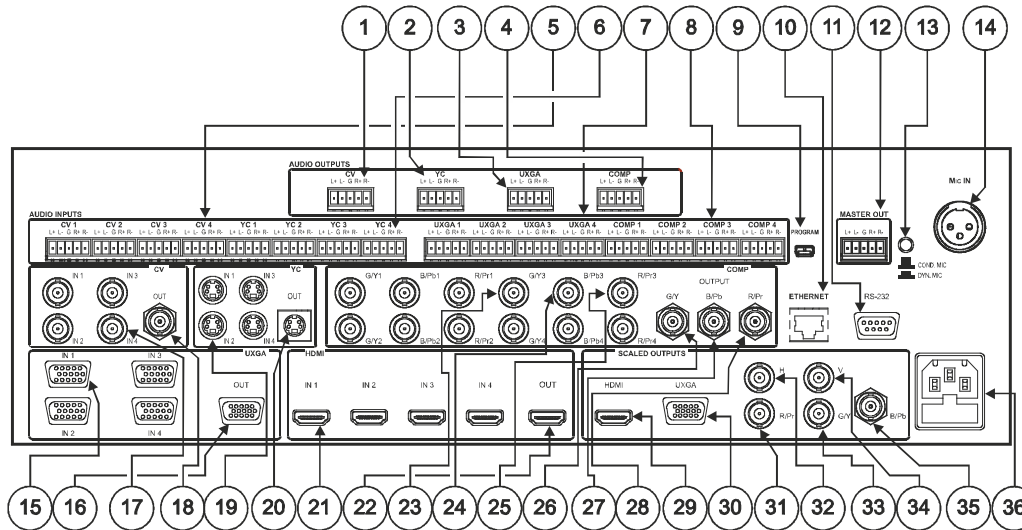

Figure 2: VP-725NA Presentation Switcher/Scaler Rear Panel

Rear Panel			
#	Feature		Function
1	<b>AUDIO OUTPUT Terminal Block Connector</b>	CV	Connects to the balanced audio acceptor (for composite)
2		YC	Connects to the balanced audio acceptor (for s-Video)
3		UXGA	Connects the balanced audio acceptor (for UXGA)
4		COMP	Connects to the balanced audio acceptor (for component)
5	<b>AUDIO INPUT Terminal Block Connector</b>	CV	Connects to the balanced audio sources, from 1 to 4 (for composite)
6		YC	Connects to the balanced audio sources, from 1 to 4 (for s-Video)
7		UXGA	Connects to the balanced audio sources, from 1 to 4 (for UXGA)
8		COMP	Connects to the balanced audio sources, from 1 to 4 (for component)

Rear Panel				
#	Feature	Function		
9	PROGRAM USB Connector	Connect to upgrade to the latest audio firmware		
10	ETHERNET port	Connects to your LAN		
11	RS-232 9-pin D-sub Connector	Connects to a PC or Serial Controller		
12	MASTER OUT Terminal Block Connector	Connects to the routed balanced audio channel		
13	COND. MIC / DYN. MIC Button	Pushed in selects a dynamic microphone, released selects a condenser microphone		
14	MIC IN XLR Connector	Connects to the microphone		
15	UXGA IN 15-pin HD Connectors	Connects to the UXGA (analog interface) graphics sources (from 1 to 4)		
16	UXGA OUT 15-pin HD Connector	Connects to the UXGA (analog interface) graphics acceptor		
17	CV IN BNC Connectors	Connects to the composite video sources (from 1 to 4)		
18	CV OUT BNC Connector	Connects to the composite video acceptor		
19	YC IN 4-pin Connectors	Connects to the s-Video (Y/C) sources (from 1 to 4)		
20	YC OUT 4-pin Connector	Connects to the s-Video (Y/C) acceptor		
21	HDMI IN Connectors	Connects to the HDMI sources (from 1 to 4)		
22	HDMI OUT Connector	Connects to the HDMI acceptor		
23	COMP Input BNC Connector	G/Y	Connect to the component video source or RGB source from (1 to 4)	
24		B/Pb		
25		R/Pr		
26	COMP OUTPUT BNC Connector	G/Y		Connect to the component video or RGB acceptor
27		B/Pb		
28		R/Pr		
29	SCALED OUTPUTS	HDMI Connector	Connects to the HDMI acceptor	
30		UXGA 15-pin HD Connector	Connects to the UXGA (analog interface) graphics acceptor	
31		BNC Connector	R/Pr	Connect to the component video or RGBHV acceptor
32			H	
33			G/Y	
34			V	
35	B/Pb			
36	Power Connector with FUSE	AC connector enabling power supply to the unit		

## 4 Installing in a Rack

This section provides instructions for rack mounting the unit.

**Before installing in a rack**, be sure that the environment is within the recommended range:

OPERATING TEMPERATURE:	0° to +55°C (32° to 131°F)
STORAGE TEMPERATURE:	-45° to +72°C (-49° to 162°F)
HUMIDITY:	10% to 90%, RHL non-condensing



### CAUTION!

When installing on a 19" rack, avoid hazards by taking care that:

1. It is located within the recommended environmental conditions, as the operating ambient temperature of a closed or multi unit rack assembly may exceed the room ambient temperature.
2. Once rack mounted, enough air will still flow around the machine.
3. The machine is placed straight in the correct horizontal position.
4. You do not overload the circuit(s). When connecting the machine to the supply circuit, overloading the circuits might have a detrimental effect on overcurrent protection and supply wiring. Refer to the appropriate nameplate ratings for information. For example, for fuse replacement, see the value printed on the product label.
5. The machine is earthed (grounded) in a reliable way and is connected only to an electricity socket with grounding. Pay particular attention to situations where electricity is supplied indirectly (when the power cord is not plugged directly into the socket in the wall), for example, when using an extension cable or a power strip, and that you use only the power cord that is supplied with the machine.

**To rack-mount a machine:**

1. Attach both ear brackets to the machine. To do so, remove the screws from each side of the machine (5 on each side), and replace those screws through the ear brackets.

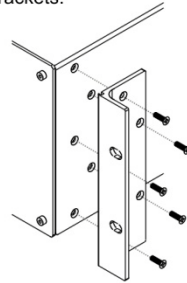

2. Place the ears of the machine against the rack rails, and insert the proper screws (not provided) through each of the four holes in the rack ears.

Note:

- In some models, the front panel may feature built-in rack ears
- Detachable rack ears can be removed for desktop use
- Always mount the machine in the rack before you attach any cables or connect the machine to the power
- If you are using a Kramer rack adapter kit (for a machine that is not 19"), see the Rack Adapters user manual for installation instructions available from our Web site

---

## 5 Connecting the VP-725NA Presentation Switcher/Scaler

This section describes how to connect the **VP-725NA**. In particular, how to connect the:

- **VP-725NA** rear panel (see [Section 5.1](#))
- Interlaced and progressive RGSB and RGsB inputs (see [Section 5.2](#))
- PC (see [Section 5.3](#))
- Ethernet port (see [Section 5.4](#))
- Audio inputs/outputs (see [Section 5.5](#))

Using the **VP-725NA** you can select any one of the 21 inputs and scale that input to up to three scaled outputs (at the identical resolution).

### 5.1 Connecting the VP-725NA

To connect the **VP-725NA**, connect the following to the rear panel, as the example in [Figure 3](#) illustrates:



Always switch off the power to each device before connecting it to your **VP-725NA**. After connecting your **VP-725NA**, connect its power and then switch on the power to each device.

1. Connect one or more of the following video sources:
  - Up to four UXGA graphics sources (for example, computers) to the 15-pin HD input connectors  
These connectors also accept interlaced and progressive RGSB and RGsB signals (see [Section 5.2](#))
  - Up to four composite video sources (for example, DVD players) to the BNC input connectors
  - Up to four s-Video sources to the 4-pin input connectors (not illustrated in [Figure 3](#))

- Up to four component video (sometimes called YUV, or Y, B-Y, R-Y, or Y, Pb/Cb, Pr/Cr) sources or four RGB sources to the four sets of 3 BNC connectors, G/Y, B/Pb, and R/Pr.  
For example, an HDTV satellite receiver to COMP IN 1 and an RGB camera connected to COMP IN 4.
  - Up to four HDMI sources (for example, DVD players) to the HDMI connectors
2. Connect one or more of the following balanced stereo audio sources (not illustrated in [Figure 3](#)):
    - UXGA sources 1 to 4 to the UXGA AUDIO INPUT terminal block connectors (from 1 to 4)
    - CV sources 1 to 4 to the CV AUDIO INPUT terminal block connectors (from 1 to 4)
    - s-Video sources 1 to 4 to the YC AUDIO INPUT terminal block connectors (from 1 to 4)
    - Component video/ RGB sources 1 to 4 to the COMP AUDIO INPUT terminal block connectors (from 1 to 4)
  3. Connect a microphone to the Mic IN XLR connector, and push in or release the Dyn/Con switch as appropriate.
  4. Connect the CV OUT BNC connector, and the UXGA OUT 15-pin HD connector to the respective video inputs on the projector. Connect the respective AUDIO OUTPUT terminal block connectors (CV and UXGA) to balanced audio acceptors (for example, audio amplifiers).
  5. Connect the COMP OUTPUT BNC connectors: G/Y, B/Pb, and R/Pr to the respective component video inputs on the LCD monitor.
  6. Connect up to three SCALED OUTPUTS, as follows:
    - Connect the RGBHV connectors (G/Y, B/Pb, R/Pr, H, and V) to the RGBHV acceptor (for example, a projector)
    - Connect the HDMI connector to the HDMI acceptor (for example, an LCD display)

- Connect the UXGA connector to the UXGA acceptor, for example, a monitor (not illustrated in [Figure 3](#))
- 7. Connect the MASTER OUT terminal block connector to the balanced audio input on the audio amplifier, and route the audio input (corresponding to the converted video input) to the MASTER OUT.
- 8. Connect the power cord (not illustrated in [Figure 3](#)).  
We recommend that you use only the power cord that is supplied with this machine.
- 9. If required connect:
  - A PC (see [Section 5.3](#)).
  - The Ethernet port (see [Section 5.4](#)).

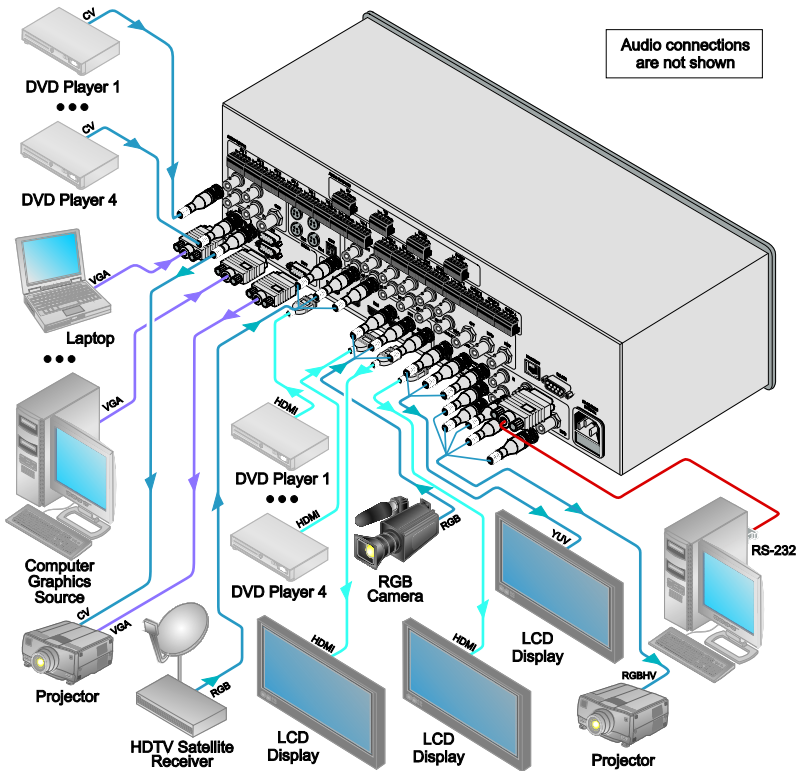

Figure 3: Connecting to the VP-725NA Presentation Switcher/Scaler

## 5.2 The RGBS and RGsB Pinouts

The following table defines the input progressive (a display mode in which all the horizontal lines of an image are displayed in a single frame, one field) and interlaced (a display mode in which a frame consists of two separate fields with the first field consisting of odd horizontal lines and the second field even horizontal lines) RGBS and RGsB pinouts:

RGBS and RGsB Pinouts		
Input	Color Space	PINOUT
VGA	RGsB	Red to PIN 1 Green + sync, to PIN 2 Blue to PIN 3
	RGBS	Red to PIN 1 Green to PIN 2 Blue to PIN 3 Hs (H and V) to PIN 13
YUV	YPbPr	Green + sync to Y Blue to Pb Red to Pr

## 5.3 Connecting to the VP-725NA via RS-232

You can connect to the unit via a crossed RS-232 connection, using for example, a PC. A crossed cable or null-modem is required as shown in method A and B respectively. If a shielded cable is used, connect the shield to pin 5.

**Method A (Figure 4)**—Connect the RS-232 9-pin D-sub port on the unit via a crossed cable (only pin 2 to pin 3, pin 3 to pin 2, and pin 5 to pin 5 need be connected) to the RS-232 9-pin D-sub port on the PC.

**Note:** There is no need to connect any other pins.

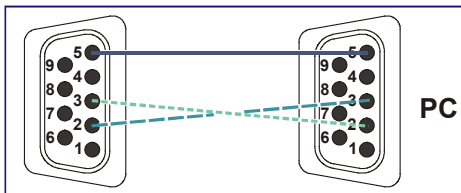

Figure 4: Crossed Cable RS-232 Connection

Hardware flow control is not required for this unit. In the rare case where a controller requires hardware flow control, short pin 1 to 7 and 8, and pin 4 to 6 on the controller side.

**Method B (Figure 5)**—Connect the RS-232 9-pin D-sub port on the unit via a straight (flat) cable to the null-modem adapter, and connect the null-modem adapter to the RS-232 9-pin D-sub port on the PC. The straight cable usually contains all nine wires for a full connection of the D-sub connector. Because the null-modem adapter (which already includes the flow control jumpering described in Method A above) only requires pins 2, 3 and 5 to be connected, you are free to decide whether to connect only these 3 pins or all 9 pins.

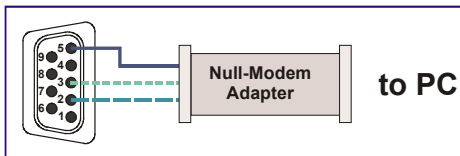

Figure 5: Straight Cable RS-232 Connection with a Null Modem Adapter

## 5.4 Connecting the VP-725NA via the ETHERNET port

You can connect the **VP-725NA** via the Ethernet, using a crossover cable (see [Section 5.4.1](#)) for direct connection to the PC or a straight through cable (see [Section 5.4.2](#)) for connection via a network hub or network router. See [Section 7.3](#) for Ethernet configuration.

### 5.4.1 Connecting the ETHERNET Port directly to a PC (Crossover Cable)

You can connect the Ethernet port of the **VP-725NA** to the Ethernet port on your PC, via a crossover cable with RJ-45 connectors.



This type of connection is recommended for identification of the factory default IP Address of the **VP-725NA** during the initial configuration.

After connecting the Ethernet port, configure your network card as follows:

1. Right-click the My Network Places icon on your desktop.
2. Select Properties and right-click Local Area Connection Properties.

3. Select Properties.

The Local Area Connection Properties window appears.

4. Select **Internet Protocol (TCP/IP)** and click the Properties Button (see [Figure 6](#)).

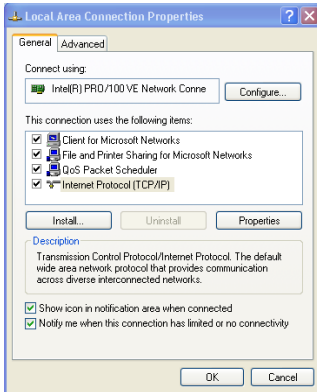

Figure 6: Local Area Connection Properties Window

5. Select **Use the following IP Address**, and fill in the details as shown in [Figure 7](#).

This IP address is compatible with the factory default IP address of the unit.

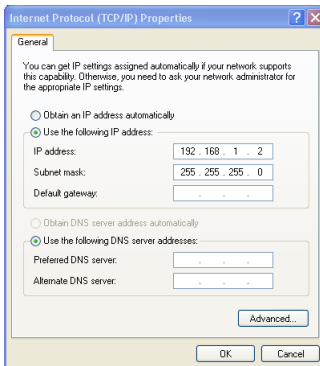

Figure 7: Internet Protocol (TCP/IP) Properties Window

6. Click OK.

### 5.4.2 Connecting the ETHERNET Port via a Network Hub (Straight-Through Cable)

You can connect the Ethernet port of the **VP-725NA** to the Ethernet port on a network hub or network router, via a straight-through cable with RJ-45 connectors.

## 5.5 Connecting the Balanced/Unbalanced Stereo Audio Input/Output

[Figure 8](#), [Figure 9](#), and [Figure 10](#) illustrate how to wire a balanced/unbalanced input and/or output connection:

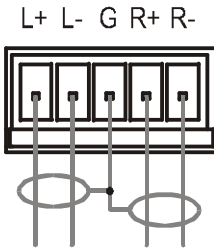

Figure 8: Connecting a Balanced Stereo Audio Input/Output

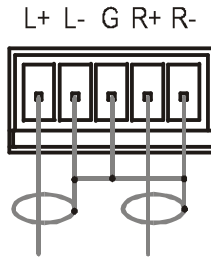

Figure 9: Connecting an Unbalanced Stereo Audio Input

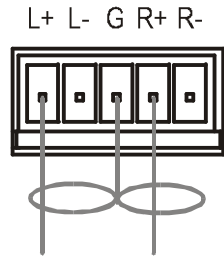

Figure 10: Connecting an Unbalanced Stereo Audio Output

---

## 6 Operating the VP-725NA Presentation Switcher/Scaler

The **VP-725NA** includes the following front panel buttons:

- A set of 21 INPUT SELECTOR buttons
- A set of Video Group and Audio Group SELECT buttons as well as Scaler Mode and Master Audio buttons

The VIDEO GROUP SELECT button selects the video input from each group to switch to its group output. The SCALER SELECT button scales the selected video input (one of 21) at each of the SCALED OUTPUTS.

- A PIP button
- A FREEZE button
- A set of 7 OSD buttons: OSD ON, MENU, ENTER, -, +, UP, and DOWN

This section describes how to:

- Use the different operating modes (see [Section 6.1](#))
- Switch an input to an output (see [Section 6.2](#))
- Understand the audio features (see [Section 6.3](#))
- Use the PIP feature (see [Section 6.4](#))
- Lock and unlock the front panel buttons (see [Section 6.5](#))
- Freeze the image (see [Section 6.6](#))
- Display a blank screen (see [Section 6.7](#))

### 6.1 Using the Operating Modes

The **VP-725NA** operates as five independent 4x1 switchers and as a scaler that switches one of the 21 inputs to the scaled outputs. These modes operate simultaneously, as well as independently.

Composite video, s-Video, component video (RGB or YPbPr), HDMI and UXGA

The four buttons in the SELECT area on the front panel let you select one of six operating modes, as defined in [Figure 11](#).





Five Independent Switchers		One Scaler		Definition
VIDEO GROUP	AUDIO GROUP	SCALER	MASTER AUDIO	
				<p><b>Video only:</b> switch the video signal of the input from 1 to 4 to the output in each of the five Video Groups</p> <p>Composite video, s-Video, component video (RGB or YPbPr), HDMI and UXGA</p>
				<p><b>Audio only:</b> switch the audio signal of the video input (from 1 to 4) to the output in each of the five Video Groups</p>
				<p><b>Video and Audio:</b> switch the video and audio signals of the input to the output in each of the five Video Groups</p>
				<p><b>Scaler Video only:</b> select one of the 21 video inputs to switch to the scaled outputs</p>
				<p><b>Master Audio only:</b> select one of the 20 audio inputs to switch to the Master Audio output</p> <p>The USB connector does not include an audio signal. However, you can assign an audio signal to the USB signal via the OSD menu</p>
				<p><b>Scaler Video and Master Audio:</b> select one of the 20 audio and video inputs to switch to the scaled outputs and Master Audio output</p>

Figure 11: Connecting an Unbalanced Stereo Audio Output

## 6.2 Switching an Input to an Output

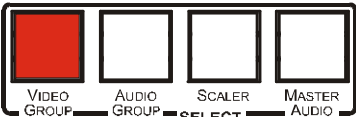
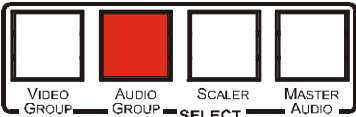
This section describes how to switch an input to an output when the **VP-725NA** operates as five independent switchers (see [Section 6.2.1](#)) and when it functions as a scaler (see [Section 6.2.2](#)).

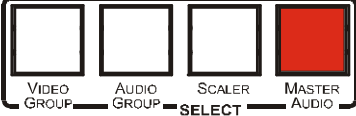

To switch an input to an output you have to first select the operating mode via the SELECT button and then select the desired inputs via the INPUT SELECTOR buttons.

### 6.2.1 Switching the VP-725NA as Five Independent Switchers

When operating the **VP-725NA** as five independent switchers, the selected input in each group is switched to the output of that group.

To operate the **VP-725NA** as five independent video switchers:  
Alternatively, press the AUDIO GROUP button to switch the audio signal only.

1. Press the VIDEO GROUP button.  
Only the VIDEO GROUP button illuminates.
2. Press an input button to switch to the output for each of the five independent switchers. For example, in the:
  - UXGA group, press INPUT 1
  - HDMI group, press INPUT 1  
The HDMI Group Output is momentarily lost during switch transitions in the unit
  - CV group, press INPUT 2
  - YC group, press INPUT 3
  - COMP group, press INPUT 4

To operate the **VP-725NA** as five independent audio-video switchers:

1. Press both the VIDEO GROUP and the AUDIO GROUP buttons.  
Both buttons illuminate.
2. Press an input button to switch to the output for each of the five independent switchers. The Audio follows the video.

## 6.2.2 Switching the VP-725NA as a Scaler

To operate the **VP-725NA** as a scaler, press the SCALER button (it illuminates) and then switch one of the 21 inputs to the scaled video outputs. If you also press the MASTER AUDIO button, the audio follows the scaled video output.

When the **VP-725NA** is in use, both modes operate simultaneously, as well as independently, that is, the Scaler output is available even when switching in the VIDEO GROUP mode, and vice versa.

## 6.3 Understanding the Audio Features

This section describes:

- Adjusting the audio level (see [Section 6.3.1](#))
- Using the Microphone CONTROL Modes (see [Section 6.3.2](#))

### 6.3.1 Adjusting the Audio Level

You can set the audio level to determine the volume for each Group input and output, as well as for the Master In, Master Out, and Mic In.

To adjust the group audio level via the front panel:

1. Press the AUDIO GROUP button.
2. Press the AUDIO LEVEL LINE button to adjust the group audio input level or press the AUDIO LEVEL OUT button to adjust the group audio output level. An OSD audio level adjustment box appears on the screen. Press the UP and DOWN buttons to scroll through the various groups.
3. Press the + and – buttons to adjust the audio level.  
Audio level within the group is adjusted for the selected input only. When selecting a different input within the group, that input updates automatically

To adjust Master Audio level via the front panel:

1. Press the MASTER AUDIO button.
2. Press the AUDIO LEVEL LINE button to adjust the master audio input level or press the AUDIO LEVEL OUT button to adjust the master audio output level.

An OSD audio level adjustment box appears on the screen.

Any selected input can have its audio level adjusted either via the MASTER AUDIO mode or the AUDIO GROUP mode and the last setting is maintained even when a different operating mode is selected. The MASTER AUDIO output level and the GROUP AUDIO output level set the master audio output and the group audio output, respectively, as illustrated in the example in [Figure 12](#).

For example, if CV input 3 audio level is set to 2 in the AUDIO GROUP mode, and then you set it at 5 in the MASTER AUDIO mode, the audio level will still be 5 (not 2) when returning to the AUDIO GROUP mode.

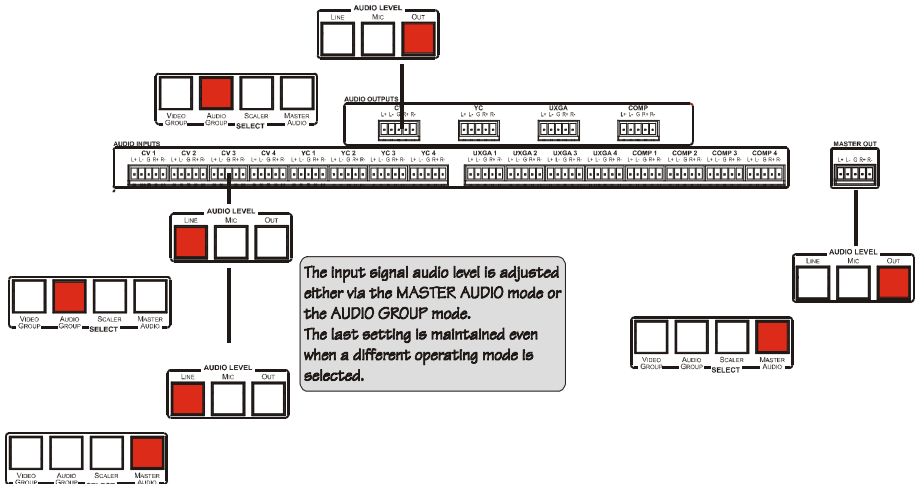

Figure 12: Adjusting the Audio Input and Audio Output Levels

### 6.3.2 Using the Microphone CONTROL Modes

The MIC CONTROL section buttons include these:

Only one of the three buttons can be ON, or all three buttons can be OFF (pressing a button will select that button, and turn OFF the previously selected button. If the selected button is pressed, it will turn it OFF)

- **Override**, that blocks the input signal and enables the microphone input to be routed to the Master output  
When no MIC CONTROL button is selected, the audio input is routed to the MASTER output, ignoring the mic input
- **Mix**, that sends the combined signals from the microphone and the line to the Master output
- **Talkover**, that routes the selected input to the output, until an audio signal is detected on the microphone input. When detected, the selected input is faded out (to be faded back in when no input is detected on the microphone)

### 6.4 Understanding the PIP Feature

The Picture-in-Picture inserter (PIP) (see [Section 7.1.2](#)) is used to display video and graphic sources simultaneously. It lets you display:

- An inserted video source (composite, s-Video) PIP over a graphic source (HDMI or UXGA or component)
- An inserted graphic source PIP over a video source

When selecting a PIP source, the Presentation Switcher/Scaler automatically recognizes and displays the selected graphic PIP source on any video source or the selected video source on any graphic source (even if the input signal is not connected. In this case the PIP appears over a blank screen.)

Main Source	PIP Source				
	VIDEO		GRAPHIC		
	CV	YC	VGA	HDMI	COMP
<b>CV</b>	No	No	Yes	Yes	Yes
<b>YC</b>	No	No	Yes	Yes	Yes
<b>VGA</b>	Yes	Yes	No	No	No
<b>HDMI</b>	Yes	Yes	No	No	No
<b>COMP</b>	Yes	Yes	No	No	No
<b>USB</b>	Yes	Yes	No	No	No

In this machine COMP is considered a graphic source even in the case where it is at video resolutions.

**Activate the PIP Feature by:**

- Pressing the PIP front panel button
- Switching on the PIP functionality via the OSD Menu (see [Section 7.1](#))
- Pressing the PIP key on the remote control transmitter (see [Section 7.3](#))

**Toggle between the PIP and screen source by:**

- Pressing the SWAP key on the remote control transmitter (see [Section 7.3](#))

**Resize the PIP by:**

- Using the OSD menu (see [Section 7.1](#))
- Pressing the PIP Size key on the remote control transmitter (see [Section 7.3](#))

**Move the position of the PIP by:**

- Using the OSD menu (see [Section 7.1](#))

**Choose a new PIP source by:**

- Pressing the "PIP Source" button on the remote control transmitter followed by the button of the desired PIP input
- Pressing and holding down the PIP front panel button and then pressing the button of the desired PIP input (while the PIP button is still pressed)

## 6.5 Locking and Unlocking the Front Panel

To prevent accidental changes to settings or unauthorized tampering with the front panel, you can lock the front panel.

To lock the front panel, press and hold the ENTER front panel button for about 3 seconds. (This does not apply to the ENTER key on the infrared remote control transmitter.)

The front panel buttons lock (except for the ENTER button on the front panel). Operation via the infrared remote transmitter or RS-232 serial commands (remote controller or PC) and/or ETHERNET is still available. The LCD displays: Keypad Lock On.

To unlock the front panel buttons (releasing the protection mechanism), press and hold the ENTER front panel button for about 3 seconds.

## 6.6 Freezing the Image

To freeze the image, press the Freeze key on the infrared remote control transmitter (see [Figure 29](#)) or the FREEZE front panel button.

The image freezes and the FREEZE front panel button illuminates.

The LCD displays: Freeze.

You can define the function of the FREEZE button (freeze and mute, freeze or mute) via the OSD menu.

## 6.7 Displaying a Blank Screen

To display a blank screen, press the Blank key on the infrared remote control transmitter (see [Figure 29](#)). You can set the blank color to blue or black and also define the function of the Blank key via the OSD menu (blank and mute, blank or mute.)

## 7 Configuring and Controlling the VP-725NA

This section describes how to configure and control the **VP-725NA** via the:

- OSD menu (see [Section 7.1](#))
- LCD display (see [Section 7.2](#))
- Infrared remote control transmitter (see [Section 7.4](#))

You can also control the **VP-725NA** via the Ethernet (see [Section 7.3](#))

### 7.1 Configuring the VP-725NA via the OSD MENU Screens

The OSD superimposes a menu on the screen from which you can configure and control each input signal on your **VP-725NA**, using the MENU, ENTER, -, +, UP and DOWN OSD buttons on the front panel and the remote transmitter.

To use the OSD menus:

1. Select the desired input signal.
2. Use the menu buttons as follows:
  - To display the main MENU screen with eight interactive icons (see [Figure 13](#)), press the MENU button on the front panel or the MENU key on the infrared remote control transmitter (see [Section 7.3](#))  
Each icon represents a Level 1 function. In addition to Level 1, the OSD structure includes Level 2 (a subset of level 1), Level 3 (a subset of level 2) and a numerical range.
  - To move to the previous level in the OSD screen (Esc), press the MENU button on the front panel or the MENU key on the infrared remote control transmitter
  - To select menu icons, press the + and – buttons and then press ENTER
  - To increase and decrease the (numerical) rate, use + and – buttons respectively



Figure 13: MENU Items

## 7.1.1 The Input Screen

Figure 14 defines the Input screen.

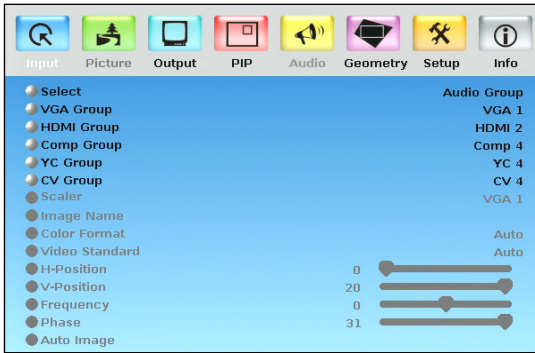

Figure 14: Input Screen

Input Screen		
Setting	Function	Default
Select	Select the group: Video Group, Scaler	Scaler
VGA Group	Select the VGA input: From 1 to 4 In the Video Group operation mode	VGA 1
HDMI Group	Select the HDMI input: From 1 to 4	HDMI 1
Comp Group	Select the Comp input: From 1 to 4	Comp 1
YC Group	Select the YC input: From 1 to 4	YC 1
CV Group	Select the CV input: From 1 to 4	CV 1
Scaler	Select the source to scale (in the Scaler operation mode): From VGA 1 to VGA 4; from HDMI 1 to HDMI 4; from COMP 1 to COMP 4; from YC 1 to YC 4; from CV 1 to CV 4, and USB	VGA 1
Image Name	Shows the file name that is displayed when the USB port is connected Supports JPEG format only. The JPEG file should not exceed a resolution of 2048x1536. If the image file is not within the definition a blank screen appears and the machine displays the message: "File too big" or "File too small" (smaller than 320x240)	
Color Format	Select the color format: Auto, RGB or YUV	Auto
Video Standard	Select the video standard: Auto, NTSC, PAL, PAL-M, PAL-N, NTSC 4.43, SECAM or PAL-60	
H-Position	Set the horizontal position (For UXGA and component video inputs): The range changes according to the input mode	Auto
V-Position	Set the vertical position: The range changes according to the input mode	
Frequency	Adjust the frequency (for the UXGA inputs): The range changes according to the input mode	
Phase	Adjust the phase: 0 to 31	0
Auto image	Assesses the image and improves the quality accordingly, by automatically adjusting the phase, frequency and position. Upon completion, the relevant OSD values are updated (Hpos, Vpos, Phase and Frequency)	

## 7.1.2 The Picture Screen

Figure 15 defines the Picture screen.

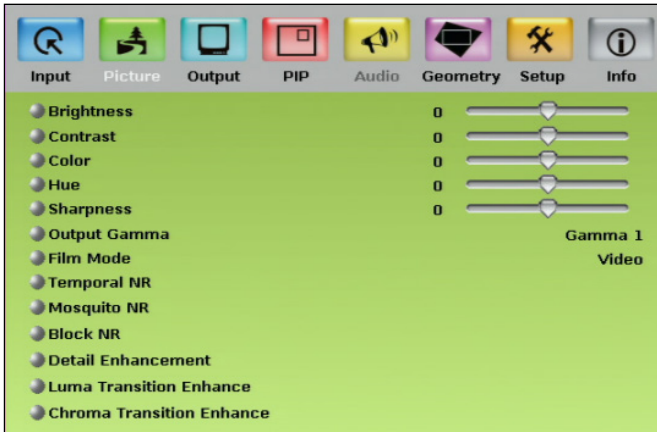

Figure 15: Picture Screen

Picture Screen		
Setting	Function	Default
Brightness	Adjust the brightness: -50 to 50	0
Contrast	Adjust the contrast: -50 to 50	0
Color	Adjust the color: -50 to 50	0
Hue	Adjust the hue: -180 to 180	0
Sharpness	Adjust the sharpness: -50 to 50	0
Output Gamma	Adjust the gamma: Gamma 1 to Gamma 5	Gamma 1
Film Mode	Set the film mode: Auto, Video, Film	Auto
Temporal NR	Set the temporal noise reduction level: Off, Low, Medium, High	High
You do not have to press ENTER after selecting the desired parameter to change it		
Mosquito NR	Set the Mosquito noise reduction level: Off, Low, Medium, High	Low
Block NR	Set the block noise reduction level: Off, On	Off
Detail Enhancement	Set the detail enhancement: Off, Low, Medium, High Set to Off for VGA and HDMI inputs; set to Medium for CV/YC/YUV inputs	Medium
Luma Transition Enhance	Set the luminance transition enhance level: Off, Low, High	Low
Chroma Transition Enhance	Set the chrominance transition enhance level: Off, Low, High	Off

### 7.1.3 The Output Screen

Figure 16 defines the Output screen.



Figure 16: Output Screen

Output Screen			
Setting	Function	Selection/Range	Default
Resolution	Set the resolution: Any change in the resolution must be confirmed via the count-down message that appears on the screen	Native HDMI, 640x480x60Hz, 640x480x75Hz, 800x600x50Hz, 800x600x60Hz, 800x600x75Hz, 1024x768x50Hz, 1024x768x60Hz, 1024x768x75Hz, 1280x768x50Hz, 1280x768x60Hz, 1280x720x60Hz, 1280x800x60Hz, 1280x1024x50Hz, 1280x1024x60Hz, 1280x1024x75Hz, 1366x768x50Hz, 1366x768x60Hz, 1400x1050x50Hz, 1400x1050x60Hz, 1600x1200x50Hz, 1600x1200x60Hz, 1680x1050x60Hz, 1920x1080x60Hz, 1920x1200x60Hz, 480px60Hz, 576px60Hz, 720px50Hz, 720px60Hz, 1080ix50Hz, 1080ix60Hz, 1080px50Hz, 1080px60Hz, 1080p@24Hz, 480p@59.94Hz, 720p@59.94Hz, 1080i@59.94Hz, 1080p@23.98Hz, 1080p@29.97Hz, 1080p@59.94Hz, or one of 4 Custom resolutions	If Native HDMI is not available, the default is 1024x768@60Hz
HDMI Type	Set the HDMI type: Auto, HDMI, DVI		auto

Output Screen			
Setting	Function	Selection/Range	Default
Aspect Ratio	Set the aspect ratio: <b>Best Fit</b> - The best possible compromise between the input and the output aspect ratios <b>Letterbox</b> <b>Follow Output</b> - Scales the picture to fill the entire output screen  When the input and output aspect ratios are the same, the only available option will be Follow Output. (The HQV considers 16:10 (for example, WUXGA, i.e. 1920x1200) and 16:9 resolutions to be the same in this regard) <b>Virtual Wide</b> <b>Follow Input</b> - Shows the picture without scaling it (pixel-to-pixel mapping) <b>Custom</b>		Follow Output
H-Pan	Horizontal pan: -16 to 16 Available when selecting Custom aspect ratio		0
V-Pan	Vertical pan: -16 to 16 Available when selecting Custom aspect ratio		0
H-Zoom	Horizontal zoom: -8 to 8 Available when selecting Custom aspect ratio		0
V-Zoom	Vertical zoom: -8 to 8 Available when selecting Custom aspect ratio		0
Zoom	Set the Zoom: 100%, 150%, 200%, 225%, 250%, 275%, 300%, 325%, 350%, 375%, 400%, Custom Available when selecting Custom aspect ratio The zoom feature is disabled in cases such as when the aspect ratio is set to custom or when the PIP feature is on		100%
Custom Zoom	Set the Zoom: From 0 to 32 (this range is equivalent to 100% to 400%) The zoom feature is disabled when the aspect ratio is set to custom or when the PIP feature is on		
Zoom H-Pan	-16 to 16 Not available if the zoom is set to 100%		0
Zoom V-Pan	-16 to 16 Not available if the zoom is set to 100%		0
HQV Color Setting	Color saturation: Adjust RGB and CMY (Cyan, Magenta and Yellow) individually (-100 to 100)		

## 7.1.1 Selecting the Correct Aspect Ratio

You can configure the aspect ratio of any output image to fit your application. The **VP-725NA** offers six different aspect ratio settings: Best Fit, Letterbox, Follow Output, Virtual Wide, Follow Input, and Custom. Here is how each of these settings works.

**BEST FIT** – This setting re-sizes the video or graphics input signal to “best fit” the output resolution while maintaining the aspect ratio of the input signal. For example, a composite video signal (4:3 aspect ratio) will “best fit” to the top and bottom of a widescreen output image, resulting in black pillars on either side.



**LETTERBOX** – This setting compresses the top and bottom edges of the input signal, but fills the width of the screen.



**FOLLOW OUTPUT** – The aspect ratio and resolution of the input signal is re-sized to precisely match the aspect ratio and resolution of the **VP-725NA** output signal. This may result in some distortion to the input signal images



**VIRTUAL WIDE** – The input signal is stretched horizontally to fit the width of a widescreen output image from the **VP-725NA**. This setting is used to expand anamorphic (horizontally compressed) video images from DVDs



**FOLLOW INPUT** – The aspect ratio and resolution of the input video or graphics signal are both preserved. For example, a composite video image with a 4:3 aspect ratio will appear with the same aspect ratio on a 1080p (16:9) output image, surrounded by black bars



**CUSTOM** – Use this menu to define a custom aspect ratio by adjusting the output image horizontal size (width) and vertical size (height)



## 7.1.2 The PIP Screen

Figure 17 defines the PIP screen.

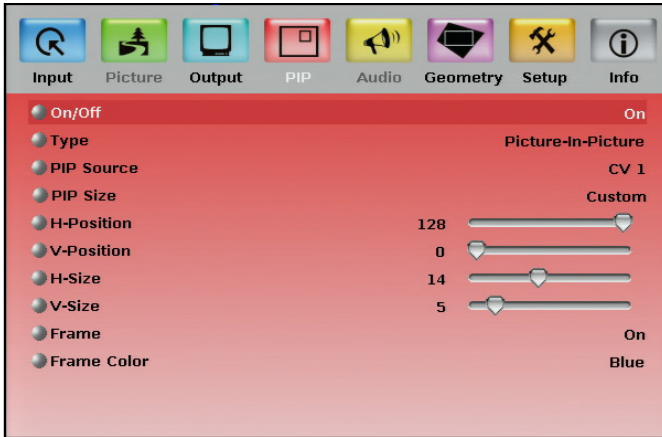

Figure 17: PIP Screen

PIP Screen		
Setting	Function	Default
On/Off	Activate/deactivate the PIP feature: On/Off When PIP is activated and that input is not connected, the PIP window appears black. If the zoom function is ON, the OSD prompts "cancel zoom?"	Off
Type	Select the PIP type: Picture-In-Picture, Picture + Picture or Split Maintains the aspect ratio	Picture-In-Picture
PIP Source	Select the PIP source: See the table in <a href="#">Section 6.2</a> When changing the PIP source, the display fades through black	
PIP Size	Select the PIP size: 1/25, 1/16, 1/9, 1/4, or Custom	1/4
H-Position	Set the horizontal position of the PIP on the display: 0 to 128	3
V-Position	Set the vertical position of the PIP on the display: 0 to 128	0
H-Size	Set custom size: 1 to 255 The actual range depends upon the input resolution	14
V-Size	Set custom size: 1 to 255 The actual range depends upon the input resolution	5
Frame	Turn the PIP frame on or off: On/Off	On
Frame Color	Select the color of the PIP frame: Red, Green or Blue	Blue

### 7.1.3 The Audio Screen

Figure 18 defines the Audio screen.

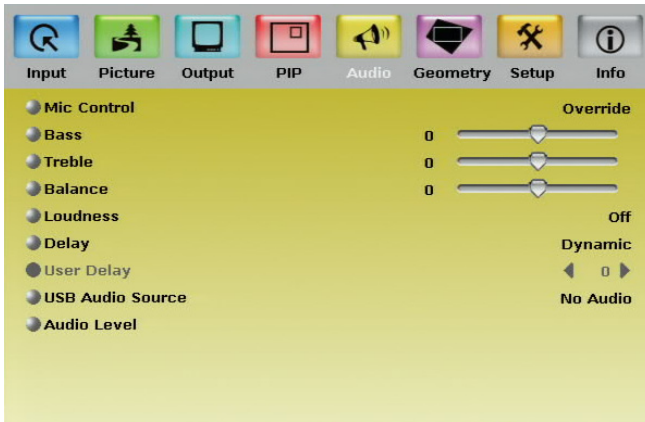

Figure 18: Audio Screen

Audio Screen			
Setting	Function	Default	
Mic Control	Set the microphone control mode: All off, Override, Mix, Talkover	All off	
Bass	Adjust the bass: -40 to 40	0	
Treble	Adjust the treble: -40 to 40	0	
Balance	Adjust the balance: -25 to 25	0	
Loudness	Set the loudness: On/Off	Off	
Delay	Define the delay type: Dynamic or User Define Dynamic means that the audio delay is equal to the pipeline video delay	Dynamic	
User Delay	Available when selecting the User Defined delay: 0 to 120 (msec) In steps of 1msec	0	
USB Audio Source	Select the USB audio source to follow the USB signal: No Audio, VGA (from 1 to 4), Comp (from 1 to 4), YC (from 1 to 4), CV (from 1 to 4)		
Audio Level	Adjust the audio input and output gains for each group (abbreviated as "Grp" in the OSD), see Figure 19:		
	VGA Grp In	VGA Grp Out	HDMI Grp In
	HDMI Grp Out	Comp Grp In	Comp Grp Out
	YC Grp In	YC Grp Out	CV Grp In
	CV Grp Out	Master In	Master Out
	Mic In		
	The audio level range for the Master Out and for the Mic In is from -100 to 24; for the Master In and group inputs and outputs it is from -30 to 10		

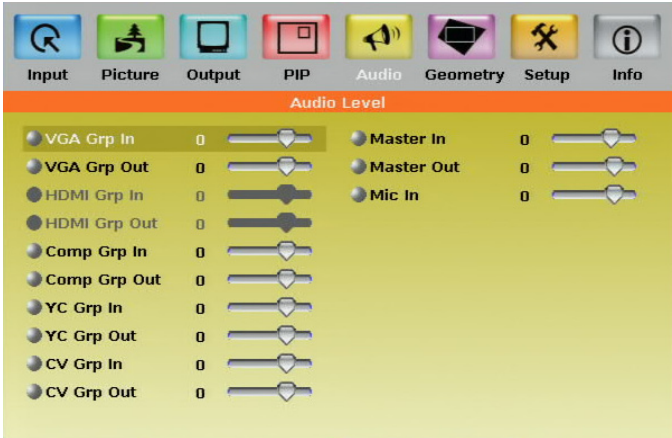

Figure 19: Audio Level Screen

## 7.1.4 The Geometry Screen

Figure 20 defines the Geometry screen, allowing the user flexibility in positioning his projector relative to the screening surface.

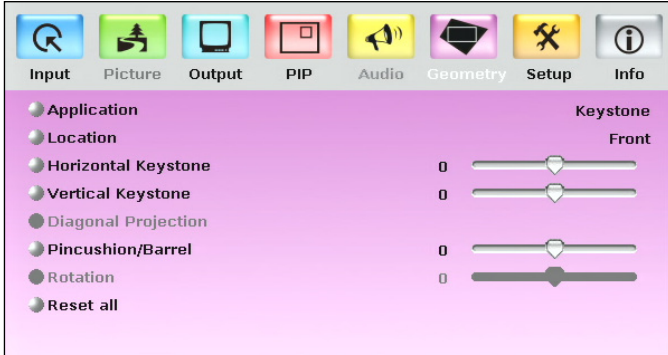

Figure 20: Geometry Screen

Geometry Screen		
Setting	Function	Default
Application	Select the output application: Keystone, Anyplace or Rotation	Keystone
Location	Select the location of the display: Front, Ceiling, Rear or Rear ceiling	Front
Horizontal Keystone	Adjust the horizontal keystone: -40 to 40 If the projector is located at an angle to the left or right of the screen	0
Vertical Keystone	Adjust the vertical keystone: -30 to 30 If the projector is located at an angle above or below the screen	0
Diagonal Projection	Move the location of each corner of the display separately, horizontally and vertically: Top Left, Top Right, Bottom Left, Bottom Right or Reset (to reset diagonal projections settings)	Top Left
Pincushion/Barrel	Adjust the pincushion or barrel appearance of the screen: -20 to 20 For projection onto curved surfaces	0
Rotation	Rotate the display clockwise or counterclockwise (in 1° increments): -180 to 180	0
Reset all	Resets the geometry settings to their default values	

Available settings for each application are listed here:

Application	Available Settings
Keystone	Location, horizontal keystone, vertical keystone, pincushion/barrel and Reset all
Anyplace	Location, Diagonal Projection and Reset all
Rotation	Location, pincushion/barrel, Rotation and Reset all

## 7.1.5 The Setup Screen

Figure 21 defines the Setup screen.



Figure 21: Setup Screen

Setup Screen		
Setting	Function	Default
Save	Save a profile: From Profile 1 to Profile 8	
Recall	Recall a profile: From Profile 1 to Profile 8	
Slideshow	Set speed for slide show (see <a href="#">Section 7.1.6</a> ): Min, Low, Mid, Long, Max, Off	Off
Frame Lock	Locks the vertical refresh rate of the output to that of the input: On/Off  Note that seamless switching is not possible when working in the Frame Lock mode unless all sources are frame synchronized.  In cases where the output resolution can support the vertical refresh rate of the input, the output refresh rate changes according to the input refresh rate	Off
Auto Image	Automatically adjust and align the picture each time one of the UXGA inputs is selected or if the UXGA input resolution has changed: Manual, Auto	Manual
Switching Mode	Select seamless switching (fade-through-Black) or fast switching which is faster but may cause glitches on the output (applies only when switching between analog inputs): Seamless, Fast	Seamless
Factory Reset	Reset your <b>VP-725NA</b> to its preset default settings: Confirm, Yes, No	
Advanced Setup	Open the advanced setups (see <a href="#">Figure 22</a> ): Mode Set, OSD, Misc., Input, Output (see <a href="#">Section 7.1.7</a> )	
EDID EEPROM Protect	EDID writing protection: On/Off  When an EDID file update is required, set the EDID protection to OFF	

Setup Screen		
Setting	Function	Default
HDMI Switch Behavior	Set to DVD/Normal or PC/Bypass: Normal/Bypass When an EDID file update is required, set the EDID protection to OFF	Normal
HDMI Input HDCP	Set to On or Off for each HDMI input HDCP support can be enabled (On) or disabled (Off) for each of the HDMI inputs, allowing the source to transmit a non-HDCP signal if required (for example, when working with a Mac computer)	ON
HDMI Group Output	Set to On or Off Set to On to enable the HDMI group or to Off to disable the HDMI group	ON

### 7.1.6 The Slideshow Feature

The **VP-725NA** lets you run a slideshow via the USB input and set the slideshow speed via the slideshow feature.

To prepare a slideshow:

1. Load the slideshow JPEG images to a USB memory stick.  
The slides appear in alphabetical order.  
JPEG files are recognized up to 2048x1536.
2. Open the Setup menu and set the desired speed in the slideshow item and then close the menu.
3. Connect the Memory stick to the USB connector on the front panel.
4. Select the USB INPUT button on the front panel.  
The slideshow begins at the set speed.



Before you run the slideshow, you must set the slideshow parameters

You can control the slide show by pressing the:

- FREEZE button to pause
- USB button to play and stop the slideshow
- Up button to go to the previous slide
- Down button to go to the next slide

## 7.1.7 The Advanced Setup Screen

Figure 22 to Figure 25 define the Advanced Setup screens.

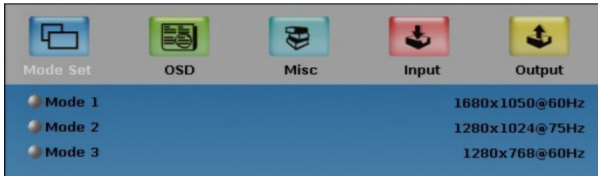

Figure 22: Advanced Setup Screen

The Mode Set functions define the desired working resolution and refresh rate when the system cannot distinguish between similar resolutions and refresh rate values.

Mode Set Functions			
Setting	Function	Selection/Range	Default
Mode 1	Set mode 1	1400x1050x60Hz 1680x1050x60Hz	1400x1050x60Hz
Mode 2	Set mode 2	1280x1024x75Hz 1280x1024x76Hz	1280x1024x75Hz
Mode 3	Set mode 3	1280x768x60Hz 1366x768x60Hz	1280x768x60Hz

OSD Functions			
Setting	Function	Selection/Range	Default
Menu Position	Set the location of the OSD menu: Center, Top Left, Top Right Bottom Left, Bottom Right		Top Right
Time Out (sec)	Set the OSD menu timeout: 5, 10, 20, 30, 60, 90 or Off		30

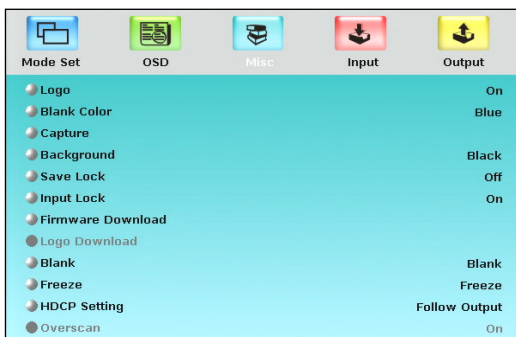

Figure 23: Misc Setup Screen

Misc Setup Screen		
Setting	Function	Default
Logo	Choose: <b>ON</b> for the start up logo to appear on the screen <b>OFF</b> for it not to appear <b>Custom</b> to download a custom Logo (Flash ROM) Obtained via the Capture function or downloaded via USB	Kramer Logo (On)
Blank Color	Set the blank color (the color that appears on the screen when the blank button is pressed): Black or Blue	Blue
Capture	Press to capture the desired image input to Flash ROM for using as a logo or as the background Prompts "Capture" The captured image is saved as the "Custom" background and/or logo The capture image size may not exceed 1280x1024	
Background	Set the background screen color: Blue, Black, Custom Selecting Custom will automatically bring up a custom (captured) screen image, that can be obtained via the Capture function or downloaded via USB (Logo Download)	Default
Save Lock	Set the Save Lock option to ON to save the lock status when the machine is powered down (On/Off)	Off
Input Lock	Set the Input Lock to OFF so you can still use the SOURCE buttons on the front panel even when the lock button is on (On/Off)	Off
Firmware Download	Download the firmware via the USB connection Select the correct file from the memory stick and Confirm. Do not press any buttons during firmware download.	
Logo Download	Download a new logo via the USB connection Available when input is not set to USB	
Blank	N/A	
Freeze	N/A	

Misc Setup Screen		
Setting	Function	Default
HDCP Setting	<p>Define whether the HDCP follows the input or the output: Follow Input, Follow Output</p> <p>When <b>Follow Input</b> is selected, the Scaler changes its HDCP output setting (for the HDMI output) according to the HDCP of the input. This option is recommended when the HDMI Scaler output is connected to a splitter/switcher (in this mode, switching may not be glitch-free)</p> <p>When <b>Follow Output</b> is selected, the Scaler matches its HDCP output to the HDCP setting of the HDMI acceptor to which it is connected. This ensures smooth switching, regardless of the input</p>	Follow output
Overscan	<p>Allows stretching of the outputted picture: On, Off</p> <p>Enabled only for HD input resolutions</p>	Off

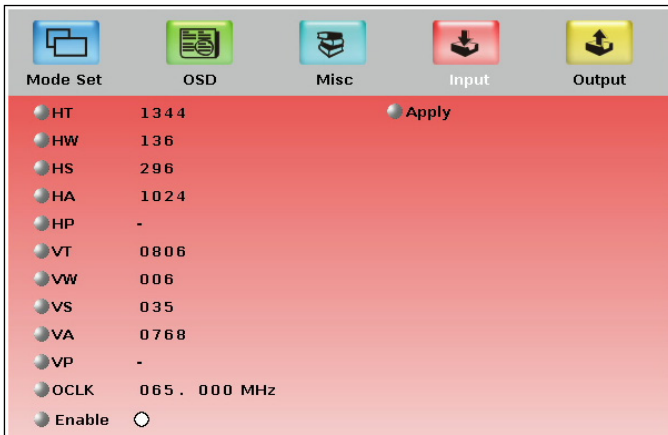

Figure 24: Input Setup Screen

Input Setup Screen			
Setting	Function	Range	Default
HT	Horizontal Total		1344
HW	Horizontal sync pulse width		136
HS	Horizontal active start point		296
HA	Horizontal active region		1024
HP	Horizontal polarity		
VT	Vertical Total		806
VW	Vertical sync pulse width		6
VS	Vertical active start point		35
VA	Vertical active region		768
VP	Vertical polarity		
OCLK	Output clock		65
Enable			off
Apply	Press to apply settings		N/A

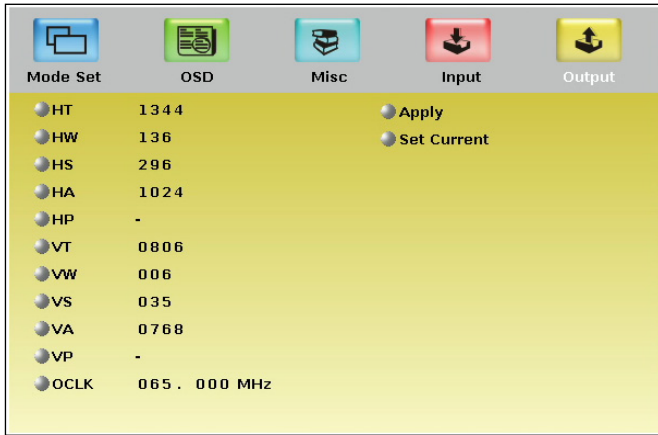

Figure 25: Output Setup Screen

Output Functions		
Setting	Function	Default
HT	Horizontal total	1344
HW	Horizontal sync pulse width	136
HS	Horizontal active start point	296
HA	Horizontal active region	1024
HP	Horizontal polarity	
VT	Vertical total	806
VW	Vertical sync pulse width	6
VS	Vertical active start point	35
VA	Vertical active region	768
VP	Vertical polarity	
OCLK	Output clock	65
Apply	Press to apply the settings	
Set Current	Import the values of the currently selected output resolution into the User Mode Setting	N/A

Figure 26 illustrates horizontal and vertical sync pulse width, timing and active video area for a typical frame of video.

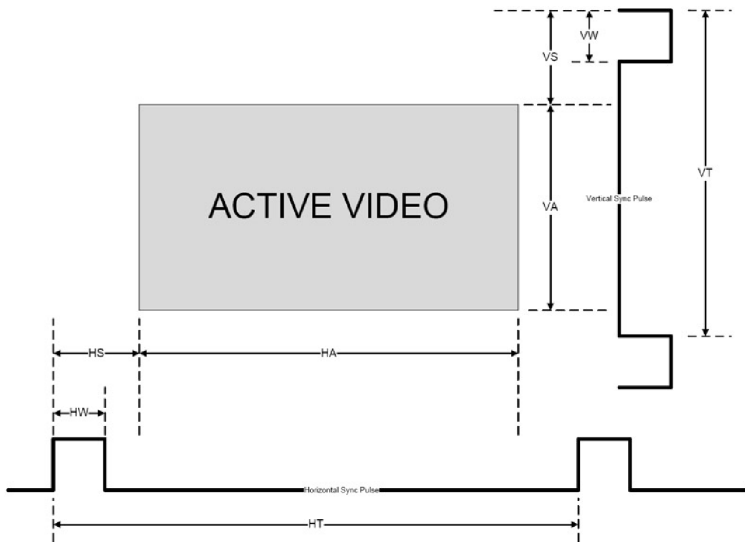

Figure 26: Active Video Functions

## 7.1.8 The Info Screen

From the Information screen (see Figure 27), you can verify the scaler source, the master audio source, the PIP source, the video group source, the output resolution, the SYNC mode (Frame lock or Free run), as well as the firmware version number and the audio board firmware version (for example, 1.2):

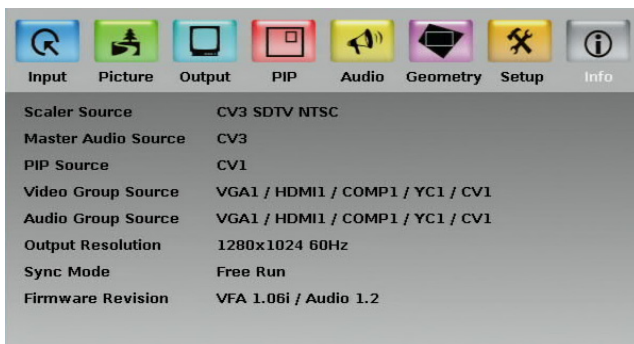

Figure 27: Information Screen

## 7.2 Operating via the LCD Display

You can control the **VP-725NA** from the front panel high contrast LCD Display. You can operate the **VP-725NA** via the LCD Display, using the:

- Front panel OSD buttons: *MENU*, *ENTER*, *-*, *+*, *UP* and *DOWN*
- Infrared remote control transmitter (see [Section 7.3](#)) keys: *MENU*, and the navigation keys

For example, to set the Keystone to 6 via the LCD Display, using the front panel buttons, do the following:

To keep the picture rectangular. [Figure 28](#) illustrates how to adjust the Keystone via the OSD Menu

1. Turn the **VP-725NA** unit ON, and press the OSD ON button (if selected) to deselect it.
2. Press the appropriate front panel OSD buttons (as defined in [Figure 28](#)).

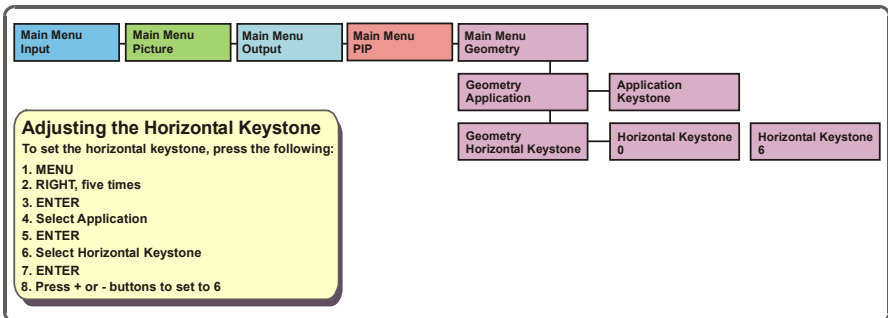

Figure 28: Example of How to Use the LCD Display

## 7.3 Operating via ETHERNET/Serial Port

To control your **VP-725NA** via the Ethernet/Serial Port:

- Connect the ETHERNET port of the **VP-725NA** to the Ethernet port of your PC, or connect the serial port of your VP-725NA to the serial port of your PC (see [Section 5.3](#))
- Download the Ethernet Application from our Web site on <http://www.kramerelectronics.com>
- Install and configure the Ethernet Application

## 7.4 Operating via the Infrared Remote Control Transmitter

You can control the **VP-725NA** remotely, from the infrared remote control transmitter (that has a range of up to 15 meters and is powered by two AAA size 1.5V DC batteries), as defined in [Figure 29](#):

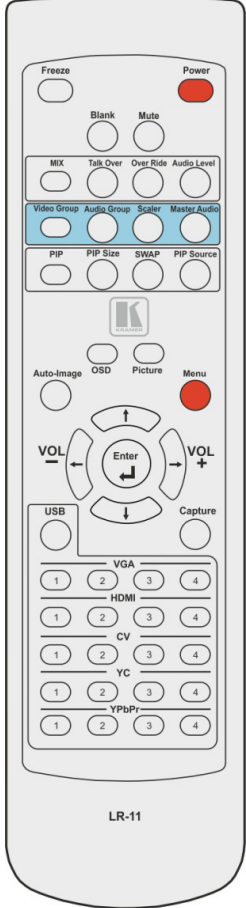

Key	Function
Freeze	Pauses the output video
Power	Cycles power
Blank	Toggles between a blank screen (blue or black screen) and the display
Mute	Mutes the audio output
MIX	Routes the combined signals from the Mic and the Line to the Master output
Talk Over	Routes the selected input to the output until an audio signal is detected on the microphone input
Over Ride	Routes the signal from the microphone to the Master output instead of from the Line, whose signal is blocked
Audio Level	Set the audio level
Video Group	Selects the Video group operation mode
Audio Group	Select the Audio Group operation mode
Scaler	Selects the Scaler operation mode
Master Audio	Select the Master Audio operation mode
PIP	Toggles the picture-in-picture function and illuminates/turns off the PIP button
PIP Size	Toggles the PIP size
SWAP	Toggles between the PIP content and the parent screen content
PIP Source	Selects the PIP source Press the PIP Source key and then an input key
Auto Image	Assesses the image and improves the quality accordingly, by automatically adjusting the phase, frequency and position
OSD	Activates/deactivates access to the OSD Menu
Picture	Opens the Picture menu Opens the menu on the LCD display and if the OSD button illuminates, opens the relevant OSD
Menu	Opens the Main menu
Navigation Arrows	Allows maneuvering within an OSD screen (left, right, up and down, as well as the Enter arrow at the center)
USB	Selects the USB source (JPEG files on a USB memory stick)
Capture	Captures an image to place as a logo or background
VGA	Selects the VGA (UXGA) source (from 1 to 4)
HDMI	Selects the HDMI source (from 1 to 4)
CV	Selects the CV source (from 1 to 4)
YC	Selects the YC source (from 1 to 4)
YPbPr	Selects the YPbPr (COMP) source (from 1 to 4)

Figure 29: Infrared Remote Control Transmitter

## 8 Using Text Overlay

The text overlay feature is accessed via the Application Program (AP).

You can download the latest software from our Web site: <http://www.kramerelectronics.com>.

Running this AP with the PC connected to the **VP-725NA** lets you display text over the screen, with features including text color and speed, transparency, text position and repetition. Current text overlay settings can be saved and loaded to the AP.

**Figure 30** defines the Text Overlay Application Screen:

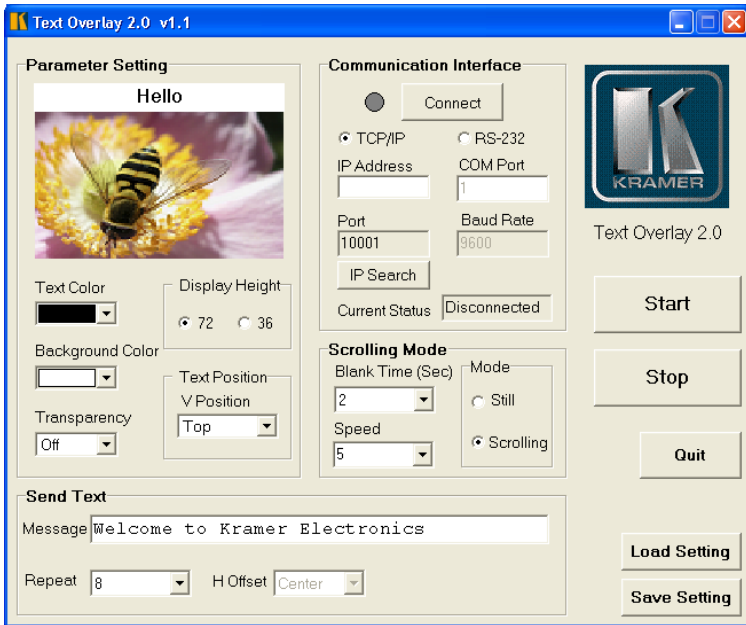

Figure 30: Text Overlay Application Screen

Text Overlay Application Screen	
Feature	Function
<b>Parameter Setting Area</b>	
<i>Text Color</i> Dropdown Box	Select the Text color
<i>Background Color</i> Dropdown Box	Set the text background color
<i>Transparency</i> Dropdown Box	Select On for a transparent background or Off for a non-transparent background
<i>Display Height</i> Check Box	Set the thickness of the background stripe (72 or 36)
<i>Text Position – V-Position</i>	Set the vertical position of the text background on the display screen (Top, Center or Bottom)
<b>Communication Interface Area</b>	
<i>Connect/Disconnect</i>	Connect the machine or disconnect
<i>TCP/IP</i> Check box	When selected, set the <i>IP Address</i> and <i>Port</i> to connect via Ethernet, or search the IP address
<i>RS-232</i> Check box	When selected, set the <i>COM port</i> and <i>Baud Rate</i> (9600) to connect via the RS-232 connector
<b>Scrolling Mode Area</b>	
<i>Blank Time (Sec) Dropdown Box</i>	Set the blank delay time (from 1 to 5)
<i>Speed</i> Dropdown Box	Set the speed at which the text moves on the display (from 1 to 5)
<i>Mode</i>	Set to <i>Still</i> (fixed text) or <i>Scrolling</i> (text moves across the display)
<b>Send Text Area</b>	
<i>Message</i>	Type the desired text in the <i>Message</i> box
<i>Repeat</i> Dropdown Box	Set the number of times that the text message scrolls across the screen (1 to 20), or set to <i>Forever</i> to repeat the text message continuously For example, set to 2 to repeat the text twice
<i>H-Offset</i> Dropdown Box	After selecting the <i>Static</i> mode, use the <i>H-Offset</i> box to select the horizontal position of the text (Left Center or Right)
<i>Start</i> Button	Click to display the text on screen
<i>Stop</i> Button	Click to stop scrolling on screen
<i>Quit</i> Button	Click to quit the program
<i>Load Setting</i> Button	Click to load a previously saved setting
<i>Save Setting</i> Button	Click to save the current setting

## 9 Technical Specifications

INPUTS:	4 x CV 1Vpp/75Ω on BNC connectors; 4 x YC 1Vpp (Y); 0.3Vpp (C)/75Ω on 4-pin connectors; 4 x Component (Y/G, Pb/B, Pr/R or RGsB) (progressive and interlaced) on BNC connectors; 4 x VGA (VGA through UXGA, RGBS or RGsB) on 15-pin HD connectors; 4 x HDMI on HDMI connectors; 16 x balanced stereo audio on terminal block connectors, 4dBu nominal; microphone on a female XLR connector
GROUP OUTPUTS:	1x CV 1Vpp/75Ω on a BNC connector; 1 x YC 1Vpp (Y); 0.3Vpp (C)/75Ω on a 4-pin connector; 1 x Component (Y/G, Pb/B, Pr/R) on BNC connectors; 1 x VGA (VGA through UXGA) on a 15-pin HD connector; 1 x HDMI on an HDMI connector; 5 x balanced stereo audio on terminal block connectors, 4dBu nominal
SCALED OUTPUTS:	1x UXGA a 15-pin HD connector; 1 x RGBHV/YPbPr on BNC connectors; 1 x HDMI on an HDMI connector
OUTPUT RESOLUTIONS:	Native HDMI, 640x480x60Hz, 640x480x75Hz, 800x600x50Hz, 800x600x60Hz, 800x600x75Hz, 1024x768x50Hz, 1024x768x60Hz, 1024x768x75Hz, 1280x768x50Hz, 1280x768x60Hz, 1280x720x60Hz, 1280x800x60Hz, 1280x1024x50Hz, 1280x1024x60Hz, 1280x1024x75Hz, 1366x768x50Hz, 1366x768x60Hz, 1400x1050x50Hz, 1400x1050x60Hz, 1600x1200x50Hz, 1600x1200x60Hz, 1680x1050x60Hz, 1920x1080@60Hz, 1920x1200@60Hz (Reduced blanking), 480px60Hz, 576px60Hz, 720px50Hz, 720px60Hz, 1080i@50Hz, 1080i 60Hz, 1080px50Hz, 1080px60Hz, 1080p@24Hz, 480p@59.94Hz, 720p@59.94Hz, 1080i@59.94Hz, 1080p@23.98Hz, 1080p@29.97Hz, 1080p@59.94Hz, or one of 4 Custom resolutions If the Native HDMI is 1920x1080x60, the preferred mode is defined as 1920x1080x60(CEA-861)
CONTROL:	Front panel buttons, IR remote control, RS-232, Ethernet; with OSD and front panel LCD
ADDITIONAL CONTROLS:	Freeze, zoom, different selectable vertical refresh rates, output image scaling, Picture-In-Picture, aspect ratio change, Geometry settings, text overlay, and so on
POWER SOURCE:	100-240V AC, 50/60Hz 38VA
DIMENSIONS:	19" x 9.3" x 3U W, D, H, rack mountable
WEIGHT:	5.5kg (12.2lbs) approx.
ACCESSORIES:	IR remote control, power cord, rack "ears", null-modem adaptor, control application programs via RS-232 (PC) and via Ethernet (i-Phone® and PC)
<p>Specifications are subject to change without notice For the most up-to-date resolution list, go to our Web site at <a href="http://www.kramerelectronics.com">http://www.kramerelectronics.com</a></p>	

Technical Specifications of the RGBHV/RGBS (PC)/RGsB (PC) Input Signal					
Resolution	Vertical Frequency (Hz)	Notes	Resolution	Vertical Frequency (Hz)	Notes
640x480 (480p)	60	VESA	1152x870	75	Mac21
640x480	67	Mac13	1152x900	66	Sun
640x480	72	VESA	1152x900	76	Sun
640x480	75	VESA	1280x720	60	VESA
640x480	85	VESA	1280x800	60	VESA
720x400	70		1280x960	60	VESA
720x400	85	VESA	1280x960	85	VESA
800x600	56	VESA	1280x768	60	VESA
800x600	60	VESA	1280x1024	60	VESA
800x600	72	VESA	1280x1024	75	VESA
800x600	75	VESA	1280x1024	76	Sun
800x600	85	VESA	1280x1024	85	VESA
832x624	75	Mac16	1366x768	60	VESA
1024x768	60	VESA	1440x900	60	VESA
1024x768	70	VESA	1400x1050	60	VESA
1024x768	75	VESA	1400x1050	75	VESA
1024x768	75	Mac19	1600x1200	60	VESA
1024x768	85	VESA	1680x1050	60	VESA
1024x800	84	Sun	1920x1080	60	VESA
1152x864	75	VESA	1920x1200	60	VESA

Technical Specifications of the Y/C, Video Signal	
<b>Standard</b>	NTSC, NTSC4.43, PAL, PAL-M, PAL-N, SECAM, PAL-60

Technical Specifications of the HDMI Input Signal (for RGB or YUV Colorspace)		
Resolution	Vertical Frequency (Hz)	Notes
1080i	60	YPbPr
1080i	50	YPbPr
1080p	60	YPbPr
1080p	50	YPbPr
1080P	24fps	YPbPr
720p	60	YPbPr
720p	50	YPbPr
480i	60	YPbPr
480p	60	YPbPr
576i	50	YPbPr
576p	50	YPbPr

Technical Specifications of the Component Input Signal		
Resolution	Vertical Frequency (Hz)	Notes
1080i	60	YPbPr
1080i	50	YPbPr
1080p	60	YPbPr
1080p	50	YPbPr
720p	60	YPbPr
720p	50	YPbPr
480i	60	YPbPr
480p	60	YPbPr
576i	50	YPbPr
576p	50	YPbPr

Technical Specifications of the RGBHV/Comp/YPbPr Output Signal					
Resolution	Vertical Frequency (Hz)	Notes	Resolution	Vertical Frequency (Hz)	Notes
640x480	60	VESA	1366x768	60	VESA
640x480	75	VESA	1400x1050	50	
800x600	50		1400x1050	60	VESA
800x600	60	VESA	1600x1200	50	
800x600	75	VESA	1600x1200	60	VESA
1024x768	50		1920x1080	60	VESA
1024x768	60	VESA	1920x1200	60	VESA
1024x768	75	VESA	1680x1050	60	VESA
1280x720	60	VESA	1080i	60	Comp/YPbPr
1280x768	50		1080i	50	
1280x768	60	VESA	720p	60	
1280x800	60	VESA	720p	50	
1280x1024	50		480p	60	
1280x1024	60	VESA	576p	50	
1280x1024	75	VESA	1080p	50	
1366x768	50		1080p	60	

Technical Specifications of the HDMI/DVI/RGB Output Signal					
Resolution	Vertical Frequency (Hz)	Remark	Resolution	Vertical Frequency (Hz)	Remark
640x480	60	VESA	1366x768	60	VESA
640x480	75	VESA	1400x1050	50	
800x600	50		1400x1050	60	VESA
800x600	60	VESA	1600x1200	50	
800x600	75	VESA	1600x1200	60	VESA
1024x768	50		1920x1080	60	VESA
1024x768	60	VESA	1920x1200	60	VESA
1024x768	75	VESA	1680x1050	60	VESA
1280x720	60	VESA	1080i	60	HDMI
1280x768	50		1080i	50	
1280x768	60	VESA	720p	60	
1280x800	60	VESA	720p	50	
1280x1024	50		480p	60	
1280x1024	60	VESA	576p	50	
1280x1024	75	VESA	1080p	50	
1366x768	50		1080p	60	

---

## 10 VP-725NA Communication Protocol

Communication Confirmation:

Send: CR

Reply: CR>

Set and Get command:

**Set** Command: Y ■ Control\_Type ■ Function ■ Param ■ CR

**Reply:** Z ■ Control\_Type ■ Function ■ Param ■ CR>

**Get** Command: Y ■ Control\_Type ■ Function ■ CR

**Reply:** Z ■ Control\_Type ■ Function ■ Param ■ CR>

Example 1 (select VGA1 as video input channel):

"Y ■ 0 ■ 157 ■ 0 ■ CR"

"Z ■ 0 ■ 157 ■ 0 ■ CR>"

Example 2 (get selected current input channel):

"Y ■ 1 ■ 157 ■ CR"

"Z ■ 1 ■ 157 ■ 0 ■ CR>" (0 = VGA 1)

Definition:

■: ASCII Code 0x20

CR: ASCII Code 0x0D

After a set type Command setting, system responds with a string "Done".

The default data rate is 9600 Baud, with no parity, 8 data bits and 1 stop bit.

Communication Protocol of the VP-725NA				
Control Type		Function	Parameter	Description
Set	Get			
0	1	5	0: Auto 1: RGB 2: YUV	Input Color Format
0	1	6	0: Auto 1: NTSC 2: PAL 3: PAL-M 4: PAL-N 5: NTSC 4.43 6: SECAM 7: PAL-60	Input Video Standard
0	1	7	0 ~ 40	Input H-Position (the parameter range is set according to the input mode)
0	1	8	0 ~ 100	Input V-Position (the parameter range is set according to the input mode)
0	1	9	-50 ~ 50	Input Frequency (the parameter range is set according to the input mode)
0	1	10	0 ~ 31	Input Phase
0	-	11	N/A	Input Auto Image
0	1	12	-50 ~ 50	Picture Brightness
0	1	13	-50 ~ 50	Picture Contrast
0	1	14	-50 ~ 50	Picture Color
0	1	15	-180 ~ 180	Picture Hue
0	1	16	-50 ~ 50	Picture Sharpness
0	1	17	0: Gamma 1 1: Gamma 2 2: Gamma 3 3: Gamma 4 4: Gamma 5	Picture Output Gamma
0	1	18	0: Auto 1: Video 2: Film	Picture Film Mode
0	1	19	0: Off 1: Low 2: Medium 3: High	Picture Temporal NR
0	1	20	0: Off 1: Low 2: Medium 3: High	Picture Mosquito NR
0	1	21	0: Off 1: On	Picture Block NR
0	1	22	0: Off 1: Low 2: Medium 3: High	Picture Detail Enhancement
0	1	23	0: Off 1: Low 2: High	Picture Luma Transition Enhance
0	1	24	0: Off 1: Low 2: High	Picture Chroma Transition Enhance

### Communication Protocol of the VP-725NA

Control Type		Function	Parameter	Description
Set	Get			
0	1	25	0: Native HDMI 1: 640x480@60Hz 2: 640x480@75Hz 3: 800x600@50Hz 4: 800x600@60Hz 5: 800x600@75Hz 6: 1024x768@50Hz 7: 1024x768@60Hz 8: 1024x768@75Hz 9: 1280x768@50Hz 10: 1280x768@60Hz 11: 1280x720@60Hz 12: 1280x800@60Hz 13: 1280x1024@50Hz 14: 1280x1024@60Hz 15: 1280x1024@75Hz 16: 1366x768@50Hz 17: 1366x768@60Hz 18: 1400x1050@50Hz 19: 1400x1050@60Hz 20: 1600x1200@50Hz 21: 1600x1200@60Hz 22: 1680x1050@60Hz 23: 1920x1080@60Hz 24: 1920x1200@60Hz 25: 480p@60Hz 26: 576p@60Hz 27: 720p@50Hz 28: 720p@60Hz 29: 1080i@50Hz 30: 1080i@60Hz 31: 1080p@50Hz 32: 1080p@60Hz 33: 1080p@24Hz 34: 480p@59.94Hz 35: 720p@59.94Hz 36: 1080i@59.94Hz 37: 1080p@23.98Hz 38: 1080p@29.97Hz 39: 1080p@59.94Hz 96: Custom1 97: Custom2 98: Custom3 99: Custom4	Output Resolution
0	1	26	0: Auto 1: HDMI 2: DVI	Output HDMI Type
0	1	27	0: Best Fit 1: Letterbox 2: Follow Output 3: Virtual Wide 4: Follow Input 5: Custom	Aspect Ratio
0	1	28	-16 ~ 16	H-Pan
0	1	29	-16 ~ 16	V-Pan

Communication Protocol of the VP-725NA				
Control Type		Function	Parameter	Description
Set	Get			
0	1	30	-8 ~ 8	H-Zoom
0	1	31	-8 ~ 8	V-Zoom
0	1	32	0: 100% 1: 150% 2: 200% 3: 225% 4: 250% 5: 275% 6: 300% 7: 325% 8: 350% 9: 375% 10: 400% 11: Custom	Zoom
0	1	33	0 ~ 32	Custom Zoom
0	1	34	-16 ~ 16	Zoom H-Pan
0	1	35	-16 ~ 16	Zoom V-Pan
0	1	36	0: Off 1: On	PIP On/Off
0	1	37	0: Picture-In-Picture 1: Picture + Picture 2: Split	PIP Type
0	1	38	0: VGA1 1: VGA2 2: VGA3 3: VGA4 4: HDMI1 5: HDMI2 6: HDMI3 7: HDMI4 8: COMP1 9: COMP2 10: COMP3 11: COMP4 12: YC1 13: YC2 14: YC3 15: YC4 16: CV1 17: CV2 18: CV3 19: CV4	PIP Source
0	1	39	0: 1/25 1: 1/16 2: 1/9 3: 1/4 4: Custom	PIP Size
0	1	40	0 ~ 128	PIP H-Position
0	1	41	0 ~ 128	PIP V-Position
0	1	42	1 ~ 255	PIP H-Size
0	1	43	1 ~ 255	PIP V-Size
0	1	44	0: Off 1: On	PIP Frame
0	1	45	0: Red 1: Green 2: Blue	PIP Frame Color
0	1	49	-40~0~+40	Audio Bass

Communication Protocol of the VP-725NA				
Control Type		Function	Parameter	Description
Set	Get			
0	1	50	-40~0~+40	Audio Treble
0	1	51	-25~25	Audio Balance
0	1	52	0: Off 1: On	Audio Loudness
0	1	53	0: Dynamic 1: User Define	Audio Delay
0	1	54	0~120	Audio User Delay
0	1	55	0: No audio 1: VGA1 2: VGA2 3: VGA3 4: VGA4 5: HDMI1 6: HDMI2 7: HDMI3 8: HDMI4 9: COMP1 10: COMP2 11: COMP3 12: COMP4 13: YC1 14: YC2 15: YC3 16: YC4 17: CV1 18: CV2 19: CV3 20: CV4	Audio Input For USB (HDMI1 / HDMI2 / HDMI3 / HDMI4 are Not Allowed)
0	1	56	0: Keystone 1: Anyplace 2: Rotation	Geometry Application
0	1	57	0: Front 1: Ceiling 2: Rear 3: Rear ceiling	Geometry Location
0	1	58	-40 ~ 40	Geometry Horizontal Keystone
0	1	59	-30~30	Geometry Vertical Keystone
0	1	60	-2000~2000	Geometry Diagonal Projection - Top Left H
0	1	61	-2000~2000	Geometry Diagonal Projection - Top Left V
0	1	62	-2000~2000	Geometry Diagonal Projection - Top Right H
0	1	63	-2000~2000	Geometry Diagonal Projection - Top Right V
0	1	64	-2000~2000	Geometry Diagonal Projection - Bottom Left H
0	1	65	-2000~2000	Geometry Diagonal Projection - Bottom Left V
0	1	66	-2000~2000	Geometry Diagonal Projection - Bottom Right H
0	1	67	-2000~2000	Geometry Diagonal Projection - Bottom Right V
0	-	68	N/A	Geometry Diagonal Projection – Reset
0	1	69	-20 ~ 20	Geometry Pincushion/Barrel
0	1	70	-180 ~ 180	Geometry Rotation
0	-	71	N/A	Geometry Reset all

Communication Protocol of the VP-725NA				
Control Type		Function	Parameter	Description
Set	Get			
0	-	72	0: Profile 1 1: Profile 2 2: Profile 3 3: Profile 4 4: Profile 5 5: Profile 6 6: Profile 7 7: Profile 8	Save Setting
0	-	73	0: Profile 1 1: Profile 2 2: Profile 3 3: Profile 4 4: Profile 5 5: Profile 6 6: Profile 7 7: Profile 8	Recall Setting
0	1	74	0: Off 1: On	Frame Lock
0	-	75	N/A	Factory Reset
-	1	76	N/A	Firmware Revision
0	1	77	0: 1400x1050x60 1: 1680x1050x60	Mode Set – Mode 1
0	1	78	0: 1280x1024x75 1: 1280x1024x76	Mode Set – Mode 2
0	1	79	0: Center 1: Top Left 2: Top Right 3: Bottom Left 4: Bottom Right	OSD Menu Position
0	1	80	0: 5 sec 1: 10 sec 2: 20 sec 3: 30 sec 4: 60 sec 5: 90 sec 6: Off	OSD Time Out
0	1	81	0: Off 1: On 2: Custom	Logo
0	1	82	0: Black 1: Blue	Blank Color
0	-	83	N/A	Capture
0	1	84	0: Black 1: Blue 2: Custom	Background
0	1	85	0: Off 1: On	Save Lock
0	1	86	0: Off 1: On	Input Lock
0	1	87	0: Blank & Mute 1: Blank 2: Mute	Blank key function
0	1	88	0: Freeze & Mute 1: Freeze 2: Mute	Freeze key function

Communication Protocol of the VP-725NA					
Control Set	Type		Function	Parameter	Description
	Get	Set			
0	1		89	0: Off 1: On	Freeze
0	1		90	0: Off 1: On	Blank
0	1		91	0: Off 1: On	Power
0	-		92	N/A	Info
0	-		93	N/A	Menu
0	-		94	N/A	Top
0	-		95	N/A	Down
0	-		96	N/A	Volume- (left - button)
0	-		97	N/A	Volume+ (right + button)
0	-		98	N/A	Enter
0	-		99	N/A	Picture
0	-		100	N/A	Swap
0	1		101	0: Off 1: On	Mute
0	1		102	0: Off 1: On	Lock
-	1		103	0: 640x480 60 1: 640x480 67, Mac13 2: 640x480 72 3: 640x480 75 4: 640x480 85 5: 720x400 70 6: 720x400 85 7: 800x600 56 8: 800x600 60 9: 800x600 72 10: 800x600 75 11: 800x600 85 12: 832x624 75, Mac16 13: 1024x768 60 14: 1024x768 70 15: 1024x768 75 16: 1024x768 75, Mac19 17: 1024x768 85 18: 1024x800 84, Sun 19: 1152x864 75 20: 1152x870 75, Mac21 21: 1152x900 66, Sun 22: 1152x900 76, Sun 23: 1280x960, 60 24: 1280x960 85 25: 1280x768 60 26: 1280x1024 60 27: 1280x1024 75 28: 1280x1024 76, Sun 29: 1280x1024 85 30: 1400x1050 60 31: 1400x1050 75 32: 1600x1200 60 33: 1680x1050 60 34: 1080i 60 35: 1080i 50	Main Input status

### Communication Protocol of the VP-725NA

Control Type		Function	Parameter	Description
Set	Get			
			36: 1080p 60 37: 1080p 50 38: 720p 60 39: 720p 50 40: 480i 41: 480p 42: 576i 43: 576p 44: 1280x800 60 (R) 45: 1920x1200 60 46: 1920x1080 60 47: 1280x720 60 48: 1080p 24 49: 1280x800 60 50: 1440x900 60 51: 1440x900 60(R) 52: 1280x768 (R) 53: 1680x1050 60 (R) 54: 1366x768 60 55: 1366x768 60 (R) 94: Custom1 95: Custom2 96: Custom3 97: Custom4 98: No Input detected 99: other 101: NTSC 102: PAL 103: PAL-M 104: PAL-N 105: NTSC 4.43 106: SECAM 107: PAL-60	
-	1	104	0: 640x480 60 1: 640x480 67, Mac13 2: 640x480 72 3: 640x480 75 4: 640x480 85 5: 720x400 70 6: 720x400 85 7: 800x600 56 8: 800x600 60 9: 800x600 72 10: 800x600 75 11: 800x600 85 12: 832x624 75, Mac16 13: 1024x768 60 14: 1024x768 70 15: 1024x768 75 16: 1024x768 75, Mac19 17: 1024x768 85 18: 1024x800 84, Sun 19: 1152x864 75 20: 1152x870 75, Mac21 21: 1152x900 66, Sun 22: 1152x900 76, Sun	PIP Input status

## Communication Protocol of the VP-725NA

Control Type		Function	Parameter	Description
Set	Get			
			23: 1280x960 60, 24: 1280x960 85 25: 1280x768 60 26: 1280x1024 60 27: 1280x1024 75 28: 1280x1024 76, Sun 29: 1280x1024 85 30: 1400x1050 60 31: 1400x1050 75 32: 1600x1200 60 33: 1680x1050 60 34: 1080i 60 35: 1080i 50 36: 1080p 60 37: 1080p 50 38: 720p 60 39: 720p 50 40: 480i 41: 480p 42: 576i 43: 576p 44: 1280x800 60 (R) 45: 1920x1200 60 46: 1920x1080 60 47: 1280x720 60 48: 1080p 24 49: 1280x800 60 50: 1440x900 60 51: 1440x900 60(R) 52: 1280x768 60(R) 53: 1680x1050 60 (R) 54: 1366x768 60 55: 1366x768 60 (R) 94: Custom1 95: Custom2 96: Custom3 97: Custom4 98: No Input detected 99: other 101: NTSC 102: PAL 103: PAL-M 104: PAL-N 105: NTSC 4.43 106: SECAM 107: PAL-60	
0	1	105	512~3071	Advance Input Mode: HT
0	1	106	32~(HS-48)	Advance Input Mode: HW
0	1	107	80~(HT-HA-12)	Advance Input Mode: HS
0	1	108	640~1920 <= (HT-92)	Advance Input Mode: HA
0	1	109	0: Negative polarity 1: Positive polarity	Advance Input Mode: HP
0	1	110	384~2047	Advance Input Mode: VT
0	1	111	2~(HS-13)	Advance Input Mode: VW

### Communication Protocol of the VP-725NA

Control Type		Function	Parameter	Description
Set	Get			
0	1	112	15~(VT-VA-1)	Advance Input Mode: VS
0	1	113	480~1200 <= (VT-16)	Advance Input Mode: VA
0	1	114	0: Negative polarity 1: Positive polarity	Advance Input Mode: VP
0	1	115	25 < OCLK < 165	Advance Input Mode: OCLK(Integer)
0	1	116	25 < OCLK < 165	Advance Input Mode: OCLK(Decimal)
0	1	117	0: Off 1: On	Advance Input Mode: Enable
0	-	118	N/A	Advance Input Mode: Save
0	1	119	512~3071	Advance Output Mode: HT
0	1	120	32~(HS-48)	Advance Output Mode: HW
0	1	121	80~(HT-HA-12)	Advance Output Mode: HS
0	1	122	640~1920 <= (HT-92)	Advance Output Mode: HA
0	1	123	0: Negative polarity 1: Positive polarity	Advance Output Mode: HP
0	1	124	384~2047	Advance Output Mode: VT
0	1	125	2~(HS-13)	Advance Output Mode: VW
0	1	126	15~(VT-VA-1)	Advance Output Mode: VS
0	1	127	480~1200 <= (VT-16)	Advance Output Mode: VA
0	1	128	0: Negative polarity 1: Positive polarity	Advance Output Mode: VP
0	1	129	25 < OCLK < 165	Advance Output Mode: OCLK(Integer)
0	1	130	25 < OCLK < 165	Advance Output Mode: OCLK(Decimal)
0	-	131	N/A	Advance Output Mode: Save
0	-	132	N/A	Advance Output Mode: Set Current
0	1	135	0: Follow Output 1: Follow Input	HDCP Setting
0	1	136	0: Custom1 1: Custom2 2: Custom3 3: Custom4	Advance Input Mode: Custom Input
0	1	137	0: Custom1 1: Custom2 2: Custom3 3: Custom4	Advance Output Mode: Custom Output
0	1	138	0: Off 1: On	Overscan
0	1	139	0: Seamless 1: Fast	Switching Mode
0	1	140	0: Manual 1: Auto	Auto Image Mode
0	-	141	N/A	Slideshow Start
0	-	142	N/A	Slideshow Stop
0	-	143	N/A	Slideshow Pause
0	-	144	N/A	Slideshow Next
0	-	145	N/A	Slideshow Previous
0	1	146	0: Min 1: Low 2: Mid 3: Long	Slideshow

Communication Protocol of the VP-725NA				
Control Type		Function	Parameter	Description
Set	Get			
			4: Max 5: Off	
0	1	147	0: 1280x768x60 1: 1366x768x60	Mode Set – Mode 3
0	1	148	0: Off 1: On	EDID Write Protect
0	1	151	0: Video Group 1: Audio Group 2: AV Group 3: Scaler 4: Master Audio 5: Master AV	Group/Master SELECT Note : Error when SELECT ≠ Video Group/Audio Group/AV Group If there is no Audio board, parameters = 1/2/4/5 are not allowed
0	1	157	0: VGA1 1: VGA2 2: VGA3 3: VGA4 4: HDMI1 5: HDMI2 6: HDMI3 7: HDMI4 8: COMP1 9: COMP2 10: COMP3 11: COMP4 12: YC1 13: YC2 14: YC3 15: YC4 16: CV1 17: CV2 18: CV3 19: CV4 20: USB	Select Video Input channel Note : Before selecting the video input channel, command function 151 (SELECT function) must be used for Scaler or Group source For "Get" command, when SELECT = Video Group use one of these "Parameter"s: 2-1. Parameter = 0 ~ 3 for getting VGA Group 2-2. Parameter = 4 ~ 7 for getting HDMI Group 2-3. Parameter = 8 ~ 11 for getting COMP Group 2-4. Parameter = 12 ~ 15 for getting YC Group 2-5. Parameter = 16 ~ 19 for getting CV Group 2-6. Parameter = 20 or others are unavailable
0	1	158	0: All Off 1: Override 2: Mix 3: Talk Over	MIC Control
0	1	159	-30 ~ +10	VGA Group In Volume
0	1	160	-30 ~ 10	VGA Group Out Volume
0	1	161	-30 ~ +10	HDMI Group In Volume
0	1	162	-30 ~ 10	HDMI Group Out Volume
0	1	163	-30 ~ +10	COMP Group In Volume
0	1	164	-30 ~ 10	COMP Group Out Volume
0	1	165	-30 ~ +10	YC Group In Volume
0	1	166	-30 ~ 10	YC Group Out Volume
0	1	167	-30 ~ +10	CV Group In Volume
0	1	168	-30 ~ 10	CV Group Out Volume
0	1	169	-30 ~ +10	Master In Volume
0	1	170	-100 ~ 24	Master Out Volume
0	1	171	-100 ~ 24	MIC In Volume
0	1	172	0: OSD ON = disable 1: OSD ON = enable	To Enable/Disable OSD ON
0	1	173	0: PIP source select = 0 1: PIP source select = 1	Hot key PIP source select, same as remote control key - PIP Source

## Communication Protocol of the VP-725NA

Control Type		Function	Parameter	Description
Set	Get			
0	1	174	0: 1/25 (for Get Command) 1: 1/16 (for Get Command) 2: 1/9 (for Get Command) 3: 1/4 (for Get Command)	Hot key PIP size, same as remote control key - PIP Size Note: For set function command, parameter is ignored
0	-	175	N/A	Hot key Master Audio, same as remote control / Keypad - Master Audio of SELECT
0	-	176	N/A	Hot key Scaler, same as remote control/Keypad - Scaler of SELECT
0	-	177	N/A	Hot key Audio Group, same as remote control / Keypad - Audio Group of SELECT
0	-	178	N/A	Hot key Video Group, same as remote control / Keypad - Video Group of SELECT
0	1	179	10: Audio Level = Master In 11: Audio Level = Master Out 12: Audio Level = Mic In 13: Audio Level = Off	Hot key Audio Level , same as remote control / Keypad - Audio Level Note : parameter must be in the range of 10 ~ 13, or it will have no effect
0	-	180	N/A	Hot key Override, same as remote control / Keypad - Override
0	-	181	N/A	Hot key Talk Over, same as remote control / Keypad - Talk Over
0	-	182	N/A	Hot key Mix, same as remote control / Keypad - Mix
0	-	183	N/A	VGA Group Output Volume Increase
0	-	184	N/A	VGA Group Output Volume Decrease
0	-	185	N/A	HDMI Group Output Volume Increase
0	-	186	N/A	HDMI Group Output Volume Decrease
0	-	187	N/A	COMP Group Output Volume Increase
0	-	188	N/A	COMP Group Output Volume Decrease
0	-	189	N/A	YC Group Output Volume Increase
0	-	190	N/A	YC Group Output Volume Decrease
0	-	191	N/A	CV Group Output Volume Increase
0	-	192	N/A	CV Group Volume Decrease
0	-	193	N/A	MASTER Group Output Volume Increase
0	-	194	N/A	MASTER Group Output Volume Decrease
0	1	195	-100 ~ +100	HQV Color Setting - Red
0	1	196	-100 ~ +100	HQV Color Setting - Green
0	1	197	-100 ~ +100	HQV Color Setting - Blue
0	1	198	-100 ~ +100	HQV Color Setting - Cyan
0	1	199	-100 ~ +100	HQV Color Setting - Magenta
0	1	200	-100 ~ +100	HQV Color Setting - Yellow
0	1	201	0 : DVD/Normal 1 : PC/Bypass	HDMI1 Switching Behavior
0	1	202	0 : DVD/Normal 1 : PC/Bypass	HDMI2 Switching Behavior

Communication Protocol of the VP-725NA				
Control Type		Function	Parameter	Description
Set	Get			
0	1	203	0 : DVD/Normal 1 : PC/Bypass	HDMI3 Switching Behavior
0	1	204	0 : Normal 1 : Bypass (Win7)	HDMI4 Switching Behavior
0	1	205	0 : Off 1 : On	Custom Output read HDMI monitor 's EDID
0	1	206	0 : Off 1 : On	HDMI1 Input HDCP setting
0	1	207	0 : Off 1 : On	HDMI2 Input HDCP setting
0	1	208	0 : Off 1 : On	HDMI3 Input HDCP setting
0	1	209	0 : Off 1 : On	HDMI4 Input HDCP setting
0	1	210	0 : Off 1 : On	HDMI Group Output

## 10.1 Error Codes

The Error Codes	
Error Code	Description
ERR 1	Unknown command
ERR 2	Unknown function
ERR 3	Unavailable function
ERR 4	Unknown control type
ERR 5	Unavailable get function
ERR 6	Unavailable set function
ERR 7	Unavailable parameter
ERR 8	Too few arguments

## LIMITED WARRANTY

The warranty obligations of Kramer Electronics for this product are limited to the terms set forth below:

### What is Covered

This limited warranty covers defects in materials and workmanship in this product.

### What is Not Covered

This limited warranty does not cover any damage, deterioration or malfunction resulting from any alteration, modification, improper or unreasonable use or maintenance, misuse, abuse, accident, neglect, exposure to excess moisture, fire, improper packing and shipping (such claims must be presented to the carrier), lightning, power surges, or other acts of nature. This limited warranty does not cover any damage, deterioration or malfunction resulting from the installation or removal of this product from any installation, any unauthorized tampering with this product, any repairs attempted by anyone unauthorized by Kramer Electronics to make such repairs, or any other cause which does not relate directly to a defect in materials and/or workmanship of this product. This limited warranty does not cover cartons, equipment enclosures, cables or accessories used in conjunction with this product.

Without limiting any other exclusion herein, Kramer Electronics does not warrant that the product covered hereby, including, without limitation, the technology and/or integrated circuit(s) included in the product, will not become obsolete or that such items are or will remain compatible with any other product or technology with which the product may be used.

### How Long Does this Coverage Last

Seven years as of this printing; please check our Web site for the most current and accurate warranty information.

### Who is Covered

Only the original purchaser of this product is covered under this limited warranty. This limited warranty is not transferable to subsequent purchasers or owners of this product.

### What Kramer Electronics will do

Kramer Electronics will, at its sole option, provide one of the following three remedies to whatever extent it shall deem necessary to satisfy a proper claim under this limited warranty:

1. Elect to repair or facilitate the repair of any defective parts within a reasonable period of time, free of any charge for the necessary parts and labor to complete the repair and restore this product to its proper operating condition. Kramer Electronics will also pay the shipping costs necessary to return this product once the repair is complete.
2. Replace this product with a direct replacement or with a similar product deemed by Kramer Electronics to perform substantially the same function as the original product.
3. Issue a refund of the original purchase price less depreciation to be determined based on the age of the product at the time remedy is sought under this limited warranty.

### What Kramer Electronics will not do Under This Limited Warranty

If this product is returned to Kramer Electronics or the authorized dealer from which it was purchased or any other party authorized to repair Kramer Electronics products, this product must be insured during shipment, with the insurance and shipping charges prepaid by you. If this product is returned uninsured, you assume all risks of loss or damage during shipment. Kramer Electronics will not be responsible for any costs related to the removal or re-installation of this product from or into any installation. Kramer Electronics will not be responsible for any costs related to any setting up this product, any adjustment of user controls or any programming required for a specific installation of this product.

### How to Obtain a Remedy under this Limited Warranty

To obtain a remedy under this limited warranty, you must contact either the authorized Kramer Electronics reseller from whom you purchased this product or the Kramer Electronics office nearest you. For a list of authorized Kramer Electronics resellers and/or Kramer Electronics authorized service providers, please visit our web site at [www.kramerelectronics.com](http://www.kramerelectronics.com) or contact the Kramer Electronics office nearest you.

In order to pursue any remedy under this limited warranty, you must possess an original, dated receipt as proof of purchase from an authorized Kramer Electronics reseller. If this product is returned under this limited warranty, a return authorization number, obtained from Kramer Electronics, will be required. You may also be directed to an authorized reseller or a person authorized by Kramer Electronics to repair the product.

If it is decided that this product should be returned directly to Kramer Electronics, this product should be properly packed, preferably in the original carton, for shipping. Cartons not bearing a return authorization number will be refused.

### Limitation on Liability

THE MAXIMUM LIABILITY OF KRAMER ELECTRONICS UNDER THIS LIMITED WARRANTY SHALL NOT EXCEED THE ACTUAL PURCHASE PRICE PAID FOR THE PRODUCT. TO THE MAXIMUM EXTENT PERMITTED BY LAW, KRAMER ELECTRONICS IS NOT RESPONSIBLE FOR DIRECT, SPECIAL, INCIDENTAL OR CONSEQUENTIAL DAMAGES RESULTING FROM ANY BREACH OF WARRANTY OR CONDITION, OR UNDER ANY OTHER LEGAL THEORY. Some countries, districts or states do not allow the exclusion or limitation of relief, special, incidental, consequential or indirect damages, or the limitation of liability to specified amounts, so the above limitations or exclusions may not apply to you.

### Exclusive Remedy

TO THE MAXIMUM EXTENT PERMITTED BY LAW, THIS LIMITED WARRANTY AND THE REMEDIES SET FORTH ABOVE ARE EXCLUSIVE AND IN LIEU OF ALL OTHER WARRANTIES, REMEDIES AND CONDITIONS, WHETHER ORAL OR WRITTEN, EXPRESS OR IMPLIED. TO THE MAXIMUM EXTENT PERMITTED BY LAW, KRAMER ELECTRONICS SPECIFICALLY DISCLAIMS ANY AND ALL IMPLIED WARRANTIES, INCLUDING, WITHOUT LIMITATION, WARRANTIES OF MERCHANTABILITY AND FITNESS FOR A PARTICULAR PURPOSE. IF KRAMER ELECTRONICS CANNOT LAWFULLY DISCLAIM OR EXCLUDE IMPLIED WARRANTIES UNDER APPLICABLE LAW, THEN ALL IMPLIED WARRANTIES COVERING THIS PRODUCT, INCLUDING WARRANTIES OF MERCHANTABILITY AND FITNESS FOR A PARTICULAR PURPOSE, SHALL APPLY TO THIS PRODUCT AS PROVIDED UNDER APPLICABLE LAW.

IF ANY PRODUCT TO WHICH THIS LIMITED WARRANTY APPLIES IS A "CONSUMER PRODUCT" UNDER THE MAGNUSON-MOSS WARRANTY ACT (15 U.S.C.A. §2301, ET SEQ.) OR OTHER APPLICABLE LAW, THE FOREGOING DISCLAIMER OF IMPLIED WARRANTIES SHALL NOT APPLY TO YOU, AND ALL IMPLIED WARRANTIES ON THIS PRODUCT, INCLUDING WARRANTIES OF MERCHANTABILITY AND FITNESS FOR THE PARTICULAR PURPOSE, SHALL APPLY AS PROVIDED UNDER APPLICABLE LAW.

### Other Conditions

This limited warranty gives you specific legal rights, and you may have other rights which vary from country to country or state to state.

This limited warranty is void if (i) the label bearing the serial number of this product has been removed or defaced, (ii) the product is not distributed by Kramer Electronics or (iii) this product is not purchased from an authorized Kramer Electronics reseller. If you are unsure whether a reseller is an authorized Kramer Electronics reseller, please visit our Web site at [www.kramerelectronics.com](http://www.kramerelectronics.com) or contact a Kramer Electronics office from the list at the end of this document.

Your rights under this limited warranty are not diminished if you do not complete and return the product registration form or complete and submit the online product registration form. Kramer Electronics thanks you for purchasing a Kramer Electronics product. We hope it will give you years of satisfaction.



For the latest information on our products and a list of Kramer distributors, visit our Web site where updates to this user manual may be found.

**We welcome your questions, comments, and feedback.**

Web site: [www.kramerelectronics.com](http://www.kramerelectronics.com)

E-mail: [info@kramerel.com](mailto:info@kramerel.com)



**SAFETY WARNING**

Disconnect the unit from the power supply before opening and servicing