

KRAMER



USER MANUAL

MODEL:

VSM-4x4A

4x4 Seamless AV Matrix Switcher/Multi-Scaler



Scan for full manual

VSM-4x4A Quick Start Guide

This guide helps you install and use your **VSM-4x4A** for the first time.

Go to www.kramerav.com/downloads/VSM-4x4A to download the latest user manual and check if firmware upgrades are available.

Step 1: Check what's in the box

- ✓ VSM-4x4A 4x4 Seamless AV Matrix Switcher/Multi-Scaler
 - ✓ IR remote control transmitter with batteries
- ✓ 1 Set of rack ears
 - ✓ 1 Power cord
- ✓ 4 Rubber feet
 - ✓ 1 Quick start guide

Step 2: Get to know your VSM-4x4A

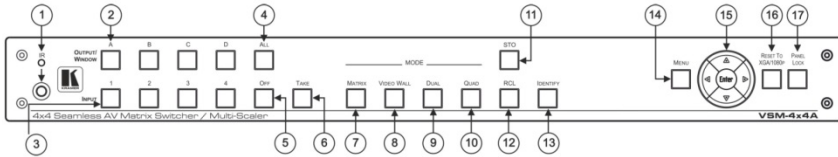

#	Feature	Function	
1	IR LED	Lights when the unit accepts IR remote commands	
	IR Receiver	Receives signals from the remote control transmitter	
2	OUTPUT/WINDOW Selector Buttons	MATRIX mode: select the output to which the input is switched (A, B, C or D) VIDEO WALL mode: not used DUAL mode: select one of the two DUAL windows: A or B for DUAL A; C or D for DUAL B QUAD mode: not used	
3	INPUT Selector Buttons	Press to select an HDMI input (from 1 to 4) to switch to the output	
4	ALL Button	Press ALL followed by an INPUT button to connect that input to all the outputs (not available for the video wall mode)	
5	OFF Button	Press after pressing an output button to disconnect the selected output from the inputs. To disconnect all the outputs, press ALL followed by OFF	
6	TAKE Button	Press to toggle between the Confirm mode (when in the Confirm mode, the TAKE button lights) and the At Once mode. When in TAKE mode, front panel buttons actions are implemented after pressing the TAKE button	
7	MODE Buttons	MATRIX	Press to operate the system as a matrix switcher
8		VIDEO WALL	Press to operate as a 2x2 or 1x4 video wall
9		DUAL	Press to operate as a 4x2 switcher with PIP capabilities
10		QUAD	Press to display all four inputs on each of the outputs
11	STO Button	Press to store a configuration	
12	RCL Button	Press to recall a configuration	
13	IDENTIFY Button	Press to indicate on each output, which input is displayed on the output. The display time is set via the OSD menu	
14	MENU	Press to access the OSD menu, exit the OSD menu and, when in the OSD menu, move to the previous level in the OSD screen	

#	Feature	Function	
15	Navigation Buttons	ENTER	Press to access sub-menu items and select from several settings
		◀	Press to decrease numerical values or select from several definitions
		▲	Press to move up the menu list values
		▶	Press to increase numerical values or select from several definitions
		▼	Press to move down the menu list
16	RESET TO XGA/1080p Button	Press and hold for about 4 seconds to toggle resetting the video resolution to XGA or 1080p	
17	PANEL LOCK Button	Press and hold for about 2 seconds to lock/unlock the front panel buttons	

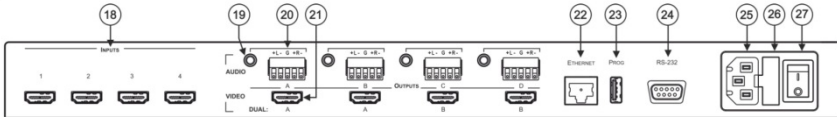

#	Feature	Function
18	INPUT HDMI Connectors	Connect to the HDMI sources (from 1 to 4)
19	AUDIO OUTPUT 3.5mm Mini Jack	Connect to an unbalanced audio acceptor (from A to D)
20	AUDIO OUTPUT 5-pin Terminal Block Connector	Connect to a balanced audio acceptor (from A to D)
21	OUTPUT HDMI Connectors	Connect to the HDMI acceptors (from A to D); DUAL: when in the dual operation mode, A, A and B, B
22	ETHERNET Connector	Connects to the PC or other Serial Controller through computer networking
23	PROG USB Connector	Connect to upgrade the unit
24	RS-232 9-pin D-sub Port	Connect to the PC or a remote controller
25	Mains Socket	Connect the mains power cord
26	Mains Fuse Holder	Fuse for protecting the device
27	Power Switch	Switch for turning the unit ON or OFF

Step 3: Install the VSM-4x4A

To rack mount the machine attach both ear brackets to the machine (by removing the three screws from each side of the machine and replacing those screws through the ear brackets) or place the machine on a table.

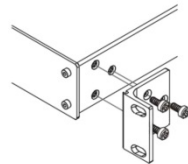

Step 4: Connect one of the four operation modes

Always switch OFF the power on each device before connecting it to your **VSM-4x4A**. For best results, we recommend that you always use Kramer high-performance cables to connect AV equipment to the **VSM-4x4A**.

The **VSM-4x4A** is a four-in-one-box device and can operate as a matrix switcher, video wall, dual switcher or quad switcher. Each of these modes includes several setup options as follows.

Mode	Optional Setups
MATRIX	<p>Seamless Matrix – 4x4 matrix switcher. The same output resolution is set for all the outputs and video switching transitions are seamless (zero-time video cuts).</p> <p>Independent Matrix – 4x4 matrix switcher. Each output resolution is set independently and video switching transitions are done via a clean, fade-through-black mechanism.</p>
VIDEO WALL	<p>2x2 – The output is displayed on a set of 4 monitors tiled in a 2x2 setting to form a large display. Each output shows one quarter of the image.</p> <p>1x4 – The output is displayed on a set of 4 monitors tiled in a 1x4 (1 column x 4 rows). The image can be cropped and positioned as desired.</p>
DUAL	<p>4x2 switcher that outputs 2 identical A outputs and 2 identical B outputs.</p> <p>POP (side-by-side) – Each A and B type outputs shows 2 images side-by-side (left and right).</p> <p>PIP (picture-in-picture) – Each A and B type outputs shows 2 images one over the other (main and pip).</p>
QUAD	Any four inputs on one screen for each of the four outputs. Each quarter of a screen shows a selected input.

MATRIX Mode

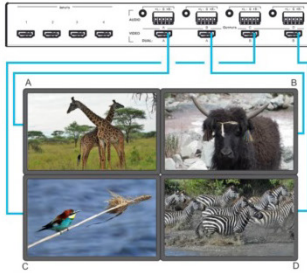

DUAL Mode

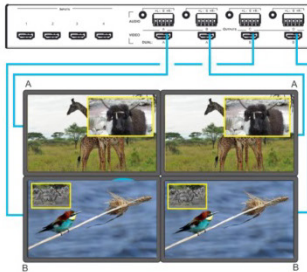

QUAD Mode

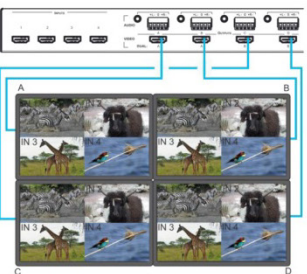

VIDEO WALL Mode: 2x2

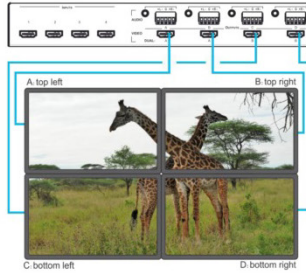

VIDEO WALL Mode: 1x4

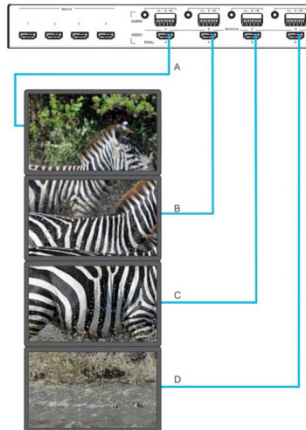

RJ-45 Pinout:
For the Ethernet and HDBaseT connectors, see the proper wiring diagram below

PIN EIA /TIA 568B	
PIN	
1	Orange / White
2	Orange
3	Green / White
4	Blue
5	Blue / White
6	Green
7	Brown / White
8	Brown

Connect the audio output:

To a balanced stereo audio acceptor

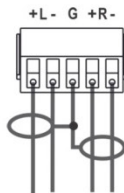

To an unbalanced stereo audio acceptor

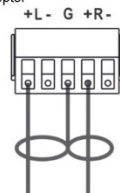

Step 5: Connect the power

Connect AC power to the rear of the **VSM-4x4A**, switch on its power and then switch on the power on each device.

Safety Instructions



- Caution:** There are no operator serviceable parts inside the unit.
Warning: Use only the power cord that is supplied with the unit.
Warning: Do not open the unit. High voltages can cause electrical shock! Servicing by qualified personnel only.
Warning: Disconnect the power and unplug the unit from the wall before installing.
 See www.KramerAV.com for updated safety information.

Step 6: Set operation parameters via OSD menu

Enter the OSD menu via the MENU button on the front panel or the IR remote control transmitter. Select a menu item and set parameters as required. By default, the output resolution is set to Native, the **VSM-4x4A** is triggered to read the EDID of OUTPUT A and change the output resolution value according to the native resolution of the display.

If you cannot see any images, verify that the display, TV, or projector is in good working order and is connected to the **VSM-4x4A**. If you still do not see an image, press and hold the RESET to XGA/1080p button for about 4 seconds to reset the outputs to XGA or 1080p resolution.

Menu	Function
Mode	Set the operation mode: matrix switcher (seamless or independent), video wall (2x2 or 1x4), Dual (POP or PIP) or Quad mode.
Picture	Set the picture parameters per operation mode (contrast, brightness saturation and hue): matrix mode (same for all outputs), video wall (separate for each output), DUAL (separate for left (main) and right (PIP), QUAD (separate for each QUAD).
Output	Set the output parameters: resolution, aspect ratio, border color, input and output labels, bezel correction, and so on.
EDID	Manage EDID: per video input as well as audio EDID.
Source	Set the input source parameters: matrix mode (any input to any output), video wall (one input to all outputs), DUAL (an input for left (main) and an input for right (PIP), QUAD (any input for each QUAD).
Recall/ Store	Store and recall setups: store/recall up to 4 setups for each operation mode.
HDCP	Set the HDCP: for each input and each output.
Other settings: set the power-save mode, the output audio level, the OSD definitions and Ethernet parameters; perform reset to factory default values and view device information.	

Step 7: Operate via the front panel buttons, Web pages and via the:

IR remote controller:



RS-232 and Ethernet:

RS-232			
Protocol 3000			
Baud Rate:	115,200	Stop Bits:	1
Data Bits:	8	Parity:	None
TCP/IP Parameters			
To reset the IP settings to the factory reset values go to : Menu-> Factory-> RESET->Change the option to YES and press Enter			
IP Address:	192.168.1.39	TCP Port #:	5000 Max. TCP Ports: 4
Subnet mask:	255.255.255.0	Default UDP Port #:	50000 Max. UDP Ports: 4
Default gateway:	192.168.1.254		
Full Factory Reset			
OSD	Go to : Menu-> FACTORY DEFAULT -> Change the option to YES and press Enter		
P3000	Use "FACTORY" command		
Front panel buttons	Press the MENU Button while plugging the power to reset the machine		
RS-232/Ethernet (UDP) Command Protocol			
Command Format:	ASCII		
Example (Route the video from the HDMI2 input to the HDMI A output port in the Matrix mode):	#ROUTE 1,1,2<cr>		

Contents

1	Introduction	1
2	Getting Started	2
2.1	Achieving the Best Performance	2
2.2	Safety Instructions	3
2.3	Recycling Kramer Products	3
3	Overview	4
3.1	Defining the VSM-4x4A	5
4	Installing in a Rack	8
5	Connecting and Operating the VSM-4x4A	9
5.1	Matrix Mode	10
5.2	Video Wall Mode	11
5.3	Dual Mode	15
5.4	Quad Mode	17
5.5	Wiring the RJ-45 Connectors	19
5.6	Connecting the Balanced Stereo Audio Line Output	19
6	Controlling the VSM-4x4A	20
6.1	Controlling via the Front Panel Buttons	20
6.2	Using the OSD Menu	26
6.3	Connecting to the VSM-4x4A via RS-232	33
6.4	Operating the VSM-4x4A via Ethernet	34
6.5	Controlling via the IR Remote Control	38
6.6	Using the IR Remote Control in Dual Mode	39
7	Firmware Upgrade	43
8	Using the Embedded Web Pages	44
8.1	Browsing the VSM-4x4A Web Pages	44
8.2	Routing & Scaling Page	45
8.3	Device Settings Page	55
8.4	Output Settings Page	61
8.5	Audio Settings Page	65
8.6	HDCP Settings Page	66
8.7	EDID Management Page	67
8.8	About Page	69
8.9	Saving and Uploading Configurations	69
9	Technical Specifications	70
9.1	Default Communication Parameters	70
9.2	Supported Input Resolutions	71
9.3	Supported Output Resolutions	71
10	VSM-4x4A RS-232/Ethernet Communication Protocol	72
10.1	Understanding Protocol 3000	73
10.2	Kramer Protocol 3000 Syntax	74
10.3	Protocol 3000 Commands	75

Figures

Figure 1: VSM-4x4A 4x4 Seamless AV Matrix Switcher/Multi-Scaler Front Panel	6
Figure 2: VSM-4x4A 4x4 Seamless AV Matrix Switcher/Multi-Scaler Rear Panel	7

Figure 3: Connecting the VSM-4x4A Presentation Switcher / Scaler	10
Figure 4: VSM-4x4A Video Wall Operation Mode	11
Figure 5: Connecting the VSM-4x4A in 2x2 Video Wall Operation Mode	12
Figure 6: Connecting the VSM-4x4A in 1x4 Video Wall Operation Mode	13
Figure 7: VSM-4x4A Bezel Correction	14
Figure 8: Connecting the VSM-4x4A in Dual Operation Mode	16
Figure 9: the VSM-4x4A QUAD Operation Mode Input Orientation	17
Figure 10: Connecting the VSM-4x4A in Quad Operation Mode	18
Figure 11: TP PINOUT	19
Figure 12: Connecting the Balanced Stereo Audio Output	19
Figure 13: Connecting an Unbalanced Stereo Audio Acceptor to the Balanced Output	19
Figure 14: Local Area Connection Properties Window	35
Figure 15: Internet Protocol Version 4 Properties Window	36
Figure 16: Internet Protocol Version 6 Properties Window	36
Figure 17: Internet Protocol Properties Window	37
Figure 18: Infrared Remote Control Transmitter	38
Figure 19: IR Remote Control Transmitter Dual Mode Shortcuts	39
Figure 20: The Routing & Scaling Page	45
Figure 21: The Matrix Tab output Resolution (Seamless Mode)	46
Figure 22: Matrix Tab output Resolution (Independent Mode)	47
Figure 23: 2x2 Video Wall Tab	48
Figure 24: 1x4 Video Wall Tab	48
Figure 25: The Video Wall Tab – Bezel Correction	49
Figure 26: The Video Wall Tab – Crop/Position Correction	49
Figure 27: The Dual Tab – POP Mode	50
Figure 28: The Dual Tab – PIP Mode	50
Figure 29: The Dual Tab – PIP Position and Size	51
Figure 30: The Quad Tab	52
Figure 31: The Matrix Tab – Store a Configuration	53
Figure 32: The Matrix Tab – Recall a Configuration	53
Figure 33: Matrix Tab – Input Edit Window	53
Figure 34: The Matrix Tab – Typing the New Label	54
Figure 35: The Matrix Tab – Viewing the Label	54
Figure 36: The Device Settings Page	55
Figure 37: The Device Settings Page – Ethernet Settings	56
Figure 38: The Device Settings Page – IP Number Settings	56
Figure 39: Device Settings Page – Information Window	57
Figure 40: Device Settings Page – Uploading the Firmware File	58
Figure 41: Device Settings Page – Firmware Upgrade Message	58
Figure 42: Device Settings Page – Firmware Upgrade Complete	59
Figure 43: The Device Settings Page – Factory Reset Message	59
Figure 44: The Device Settings Page – Factory Reset	60
Figure 45: The Output Settings Page – Matrix and Video Wall Modes	61
Figure 46: Output Settings Page – Dual-POP Mode	62
Figure 47: Output Settings Page – Dual PIP Mode	63
Figure 48: Output Settings Page – Quad Mode	64
Figure 49: The Audio Settings Page	65
Figure 50: HDCP Settings Page	66
Figure 51: EDID Management Page	67
Figure 52: EDID Management Page – selecting an Output	67
Figure 53: EDID Management Page – Copying the Native Timing	68
Figure 54: EDID Management Page – Copy EDID Results	68
Figure 55: The About Page	69
Figure 56: Loading a Configuration	69

1 Introduction

Welcome to Kramer Electronics! Since 1981, Kramer Electronics has been providing a world of unique, creative, and affordable solutions to the vast range of problems that confront video, audio, presentation, and broadcasting professionals on a daily basis. In recent years, we have redesigned and upgraded most of our line, making the best even better!

Our 1,000-plus different models now appear in 15 groups that are clearly defined by function: GROUP 1: Distribution Amplifiers; GROUP 2: Switchers and Routers; GROUP 3: Control Systems; GROUP 4: Format & Standards Converters; GROUP 5: Range Extenders & Repeaters; GROUP 6: Specialty AV Products; GROUP 7: Scalers; GROUP 8: Cables and Connectors; GROUP 9: Room Connectivity; GROUP 10: Mounting and Rack Adapters; GROUP 11: Sierra Video; GROUP 12: Digital Signage; GROUP 13: Audio; GROUP 14: Collaboration; and GROUP 15: KM & KVM Switches.

Congratulations on purchasing your Kramer **VSM-4x4A** 4x4 Seamless AV Matrix Switcher/Multi-Scaler.

The **VSM-4x4A** incorporates HDMI™ technology and is ideal for:

- Conference room presentations
- Advertising applications, shopping malls and museums
- Post production applications
- Rental and staging
- Security applications
- Video-wall scaling
- Applications with multiple inputs and outputs
- Applications where quick, sleek, seamless switching is required
- Any application requiring 4 scalers in a single 1RU rack space

2 Getting Started

We recommend that you:

- Unpack the equipment carefully and save the original box and packaging materials for possible future shipment
- Review the contents of this user manual



Go to www.kramerav.com/downloads/VSM-4x4A to check for up-to-date user manuals, application programs, and to check if firmware upgrades are available (where appropriate).

2.1 Achieving the Best Performance

To achieve the best performance:

- Use only good quality connection cables (we recommend Kramer high-performance, high-resolution cables) to avoid interference, deterioration in signal quality due to poor matching, and elevated noise levels (often associated with low quality cables)
- Do not secure the cables in tight bundles or roll the slack into tight coils
- Avoid interference from neighbouring electrical appliances that may adversely influence signal quality
- Position your Kramer **VSM-4x4A** away from moisture, excessive sunlight and dust



This equipment is to be used only inside a building. It may only be connected to other equipment that is installed inside a building.

2.2 Safety Instructions



Caution: There are no operator serviceable parts inside the unit

Warning: Use only the power cord that is supplied with the unit

Warning: Do not open the unit. High voltages can cause electrical shock! Servicing by qualified personnel only

Warning: Disconnect the power and unplug the unit from the wall before installing

2.3 Recycling Kramer Products

The Waste Electrical and Electronic Equipment (WEEE) Directive 2002/96/EC aims to reduce the amount of WEEE sent for disposal to landfill or incineration by requiring it to be collected and recycled. To comply with the WEEE Directive, Kramer Electronics has made arrangements with the European Advanced Recycling Network (EARN) and will cover any costs of treatment, recycling and recovery of waste Kramer Electronics branded equipment on arrival at the EARN facility. For details of Kramer's recycling arrangements in your particular country go to our recycling pages at www.kramerav.com/support/recycling/.

3 Overview

The **VSM-4x4A** is a 4x4 seamless matrix switcher that can also be used as a video wall driver (2x2 or 1x4) or dual and quad multi-viewers. The unit enables switching between inputs with a clean video cut (frame-to-frame switching with no glitches). The **VSM-4x4A** supports HDMI resolutions with deep color, up to eight channels of audio and includes per-port HDCP and EDID settings. The unit has 4 inputs and 4 outputs on HDMI connectors. The audio output signals are embedded in the HDMI outputs and are also output via mirrored unbalanced and balanced analog signals for each output.

The **VSM-4x4A** features:

- PixPerfect™ scaling technology – Kramer’s precision pixel mapping and high quality scaling technology
- HDTV compatibility
- HDCP compliance – The HDCP (High Definition Content Protection) license agreement allows copy-protected data on the HDMI input to pass only to the HDMI outputs
- 4 HDMI inputs and four scaled HDMI outputs
- 4 balanced and 4 unbalanced audio outputs with independent volume settings per output as well as embedded audio on the HDMI outputs
- Selectable operation modes – seamless matrix switcher (seamless or independent setup), video wall (2x2 or 1x4 configuration), dual display (Split/PIP/POP) or quad display
- Bezel correction options – in the video wall mode
- Independent switching mode allows for separate output resolutions. Input switching is not via seamless video cuts in this mode, but the switching is still clean (outputs do retain constant sync during the switch transition)
- HDMI support for Deep Color, Dolby Digital Plus, DTS, DTS-HD®, LPCM 2CH/6CH/8CH, AC3
- HDCP and EDID settings per port
- VGA to WUXGA and 480i to 1080p input resolution range

- 480p to 1080p output resolution range
- Multiple aspect ratio selections – full, 4:3, 16:9 and best fit
- Built-in ProcAmp – color, hue, sharpness, noise, contrast and brightness
- Front panel control – operation mode, TAKE button, and menu buttons
- 4 preset memory locations for each operation mode for quick access to common IN-OUT configurations
- Front panel lockout
- Non-volatile memory – saves final settings
- Additional internal memory (to support larger F/W code)
- Firmware upgrade via Ethernet or via the program mini USB connector

Control your **VSM-4x4A**:

- Directly, via the front panel push buttons
- By RS-232 serial commands transmitted by a touch screen system, PC, or other serial controller
- Remotely, from the infrared remote control transmitter with OSD (on-screen display)
- Via the Ethernet with built-in Web pages

The **VSM-4x4A** is housed in a 19" 1U rack mountable enclosure, with rack ears included, and is fed from a 100-240 VAC universal switching power supply.

3.1 Defining the **VSM-4x4A**

This section defines the **VSM-4x4A**.

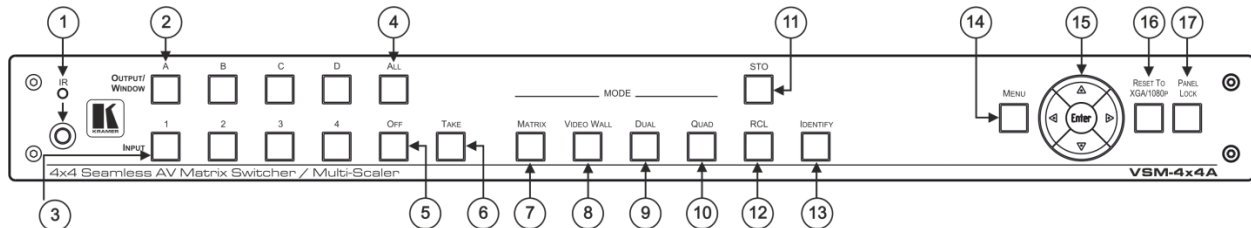

Figure 1: VSM-4x4A 4x4 Seamless AV Matrix Switcher/Multi-Scaler Front Panel

#	Feature	Function	
1	IR LED	Lights when the unit accepts IR remote commands	
	IR Receiver	Receives signals from the remote control transmitter	
2	OUTPUT/WINDOW Selector Buttons	In the MATRIX mode: select the output to which the input is switched (A, B, C or D) In the VIDEO WALL mode: not used In the DUAL mode: select one of the two DUAL windows: A or B for DUAL A; C or D for DUAL B (see Section 5.3) In the QUAD mode: not used	
3	INPUT Selector Buttons	Press to select an HDMI input (from 1 to 4) to switch to the output	
4	ALL Button	Press ALL followed by an INPUT button to connect that input to all the outputs (not available for the video wall mode)	
5	OFF Button	Press after pressing an output button to disconnect the selected output from the inputs. To disconnect all the outputs, press ALL followed by OFF	
6	TAKE Button	Press to toggle between the Confirm mode (when in the Confirm mode, the TAKE button lights) and the At Once mode. When in TAKE mode, front panel buttons actions are implemented after pressing the TAKE button (see Section 6.1.2)	
7	MODE Buttons	MATRIX	Press to operate the system as a matrix switcher (see Section 5.1)
		VIDEO WALL	Press to operate as a 2x2 or 1x4 video wall (see Section 5.2)
		DUAL	Press to operate as a 4x2 switcher with PIP capabilities (see Section 5.3)
		QUAD	Press to display all four inputs on each of the outputs (see Section 5.4)
11	STO Button	Press to store a configuration (see Section 6.1.3)	
12	RCL Button	Press to recall a configuration (see Section 6.1.3)	
13	IDENTIFY Button	Press to indicate on each output, which input is displayed on the output. The display time is set via the OSD menu (see Section 6.2.1)	

#	Feature	Function	
14	MENU	Press to access the OSD menu, exit the OSD menu and, when in the OSD menu, move to the previous level in the OSD screen (see Section 6.1.2)	
15	Navigation Buttons	ENTER	Press to access sub-menu items and select from several settings (see Section 6.1.2)
		◀	Press to decrease numerical values or select from several definitions
		▲	Press to move up the menu list values (see Section 6.1.2)
		▶	Press to increase numerical values or select from several definitions
16	RESET TO XGA/1080p Button	▶	Press to increase numerical values or select from several definitions
		▼	Press to move down the menu list (see Section 6.1.2)
16	RESET TO XGA/1080p Button	Press and hold for about 4 seconds to toggle resetting the video resolution to XGA or 1080p	
17	PANEL LOCK Button	Press and hold for about 2 seconds to lock/unlock the front panel buttons	

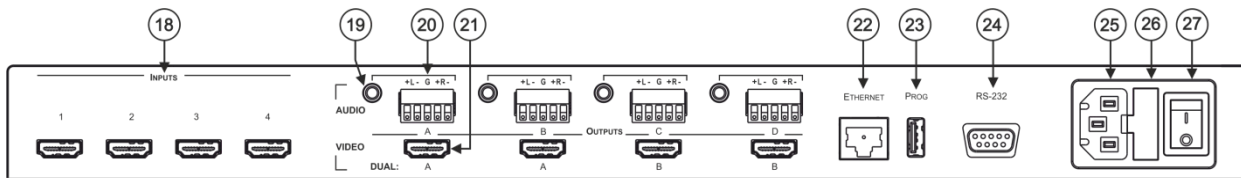

Figure 2: VSM-4x4A 4x4 Seamless AV Matrix Switcher/Multi-Scaler Rear Panel

#	Feature	Function
18	INPUT HDMI Connectors	Connect to the HDMI sources (from 1 to 4)
19	AUDIO OUTPUT 3.5mm Mini Jack	Connect to an unbalanced audio acceptor (from A to D)
20	AUDIO OUTPUT 5-pin Terminal Block Connector	Connect to a balanced audio acceptor (from A to D)
21	OUTPUT HDMI Connectors	Connect to the HDMI acceptors (from A to D); DUAL: when in the dual operation mode, A, A and B, B
22	ETHERNET Connector	Connects to the PC or other Serial Controller through computer networking
23	PROG USB Connector	Connect to upgrade the unit
24	RS-232 9-pin D-sub Port	Connect to the PC or a remote controller
25	Mains Socket	Connect the mains power cord
26	Mains Fuse Holder	Fuse for protecting the device
27	Power Switch	Switch for turning the unit ON or OFF

4 Installing in a Rack

This section provides instructions for rack mounting the unit.

Before installing in a rack, be sure that the environment is within the recommended range:

OPERATING TEMPERATURE:	0° to +40°C (32° to 104°F)
STORAGE TEMPERATURE:	-40° to +70°C (-40° to 158°F)
HUMIDITY:	10% to 90%, RHL non-condensing



CAUTION!

When installing on a 19" rack, avoid hazards by taking care that:

1. It is located within the recommended environmental conditions, as the operating ambient temperature of a closed or multi unit rack assembly may exceed the room ambient temperature.
2. Once rack mounted, enough air will still flow around the machine.
3. The machine is placed straight in the correct horizontal position.
4. You do not overload the circuit(s). When connecting the machine to the supply circuit, overloading the circuits might have a detrimental effect on overcurrent protection and supply wiring. Refer to the appropriate nameplate ratings for information. For example, for fuse replacement, see the value printed on the product label.
5. The machine is earthed (grounded) in a reliable way and is connected only to an electricity socket with grounding. Pay particular attention to situations where electricity is supplied indirectly (when the power cord is not plugged directly into the socket in the wall), for example, when using an extension cable or a power strip, and that you use only the power cord that is supplied with the machine.

To rack-mount a machine:

1. Attach both ear brackets to the machine. To do so, remove the screws from each side of the machine (3 on each side), and replace those screws through the ear brackets.

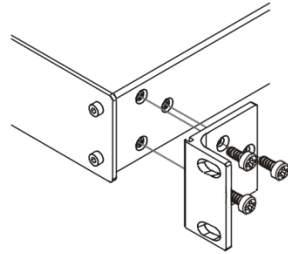

2. Place the ears of the machine against the rack rails, and insert the proper screws (not provided) through each of the four holes in the rack ears.

Note:

- In some models, the front panel may feature built-in rack ears
- Detachable rack ears can be removed for desktop use
- Always mount the machine in the rack before you attach any cables or connect the machine to the power
- If you are using a Kramer rack adapter kit (for a machine that is not 19"), see the Rack Adapters user manual for installation instructions available from our Web site

5 Connecting and Operating the VSM-4x4A

The **VSM-4x4A** is a four-in-one box device. It can operate as a:

- Matrix switcher
- Video wall
- Dual switcher
- Quad switcher

You can select the different operation modes via front panel buttons, the IR remote control transmitter and OSD menu or via the Web pages.

This section describes how to connect and operate the **VSM-4x4A** in each of the four operation modes.



Always switch off the power to each device before connecting it to your **VSM-4x4A**. After connecting your **VSM-4x4A**, connect its power and then switch on the power to each device.



This section describes selecting inputs via the front panel buttons.

To select the inputs via the OSD, use the SOURCE menu item (see [Section 6.2.1](#)).

To select the inputs via the IR remote control transmitter, see [Section 6.6](#).



You do not have to connect all the inputs and outputs, connect only those that are required.

5.1 Matrix Mode

The **VSM-4x4A** matrix switcher mode is the default operation mode. Any of the four inputs can be switched to any of the four outputs. Switching is immediate and seamless.

5.1.1 Connecting the VSM-4x4A in Matrix Mode

To connect the **VSM-4x4A** in Matrix mode, as illustrated in the example in [Figure 3](#):

1. Connect up to four HDMI sources (for example, laptops and/or Blu-ray disk players) to the HDMI INPUT connectors (from INPUT 1 to INPUT 4).
2. Connect the four HDMI OUTPUT connectors (from OUTPUT A to OUTPUT D) to up to four HDMI acceptors (for example, displays and/or projectors).
3. Connect the four OUTPUT unbalanced stereo audio 3.5mm mini jacks and/or the four balanced stereo audio terminal block connectors (see [Section 5.6](#)) to up to four audio acceptors (for example, active speakers or audio power amplifiers).
4. Connect the power cord.
5. If required, connect:
 - A PC via RS-232, see [Section 6.3](#)
 - The ETHERNET port, see [Section 6.4](#)

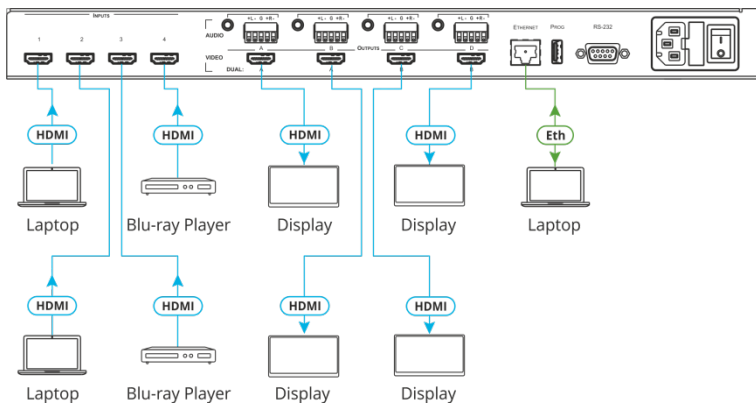

Figure 3: Connecting the VSM-4x4A Presentation Switcher / Scaler

5.1.2 Operating the VSM-4x4A in Matrix Mode

To select the inputs via the front panel buttons/IR remote control transmitter:

1. Press **MATRIX MODE** on the front panel to select the Matrix operation mode.
2. Press **MENU** on the front panel to display the OSD menu (see [Section 6.2](#)) and define the matrix switcher option (seamless or independent).
3. Press an output (A to D) button and then an input button (1 to 4) to switch to the selected output.
4. If required, press **TAKE** to switch several inputs and outputs at once (see [Section 6.1.2](#)).

5.2 Video Wall Mode

In Video Wall mode, you can display the output on a set of four monitors / projectors / TV sets that are tiled together in a 2x2 or 1x4 setting to form one large display. Each output shows one quarter of the image as shown in the example in [Figure 4](#).

In Video Wall mode, the audio of the selected input is routed to one of the outputs.

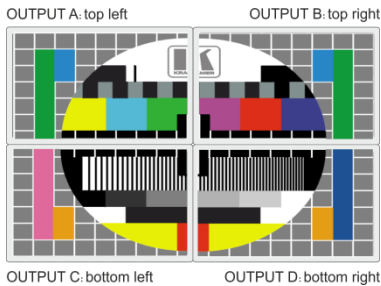

Figure 4: VSM-4x4A Video Wall Operation Mode

5.2.1 Connecting the VSM-4x4A in Video Wall Mode

To connect the video wall as illustrated in [Figure 5](#) and [Figure 6](#):

1. Connect the inputs, not shown in [Figure 5](#) and [Figure 6](#).

2. Connect the HDMI output connectors to the video wall screens, as follows:

For a 2x2 setup, connect:

- OUTPUT A to the top left screen
- OUTPUT B to the top right screen
- OUTPUT C to the bottom left screen
- OUTPUT D to the bottom right screen

For a 1x4 setup, connect OUTPUT A to the top screen, outputs B and C below in sequence, and OUTPUT D to the lowest screen.

3. Connect the power cord.

4. If required, connect:

- A PC via RS-232, see [Section 6.3](#)
- The ETHERNET port, see [Section 6.4](#)

[Figure 5](#) shows a 2x2 video wall layout:

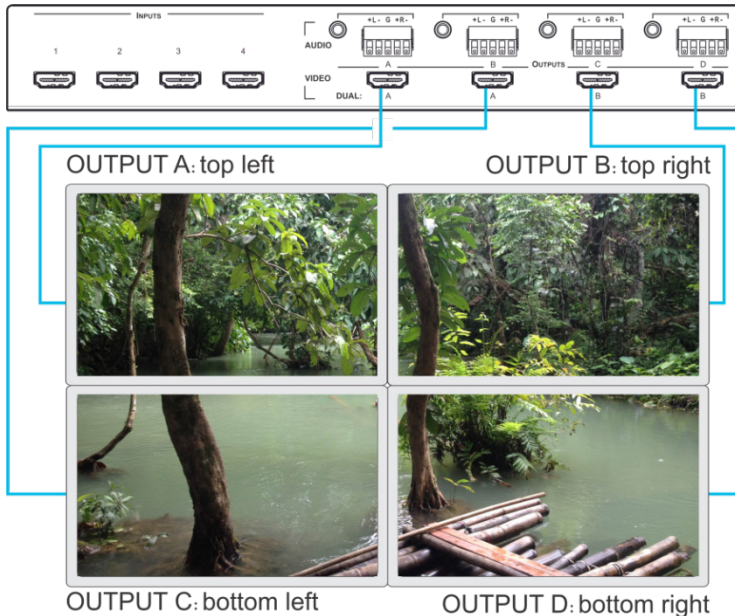

Figure 5: Connecting the VSM-4x4A in 2x2 Video Wall Operation Mode

Figure 6 shows a 2x2 video wall layout:

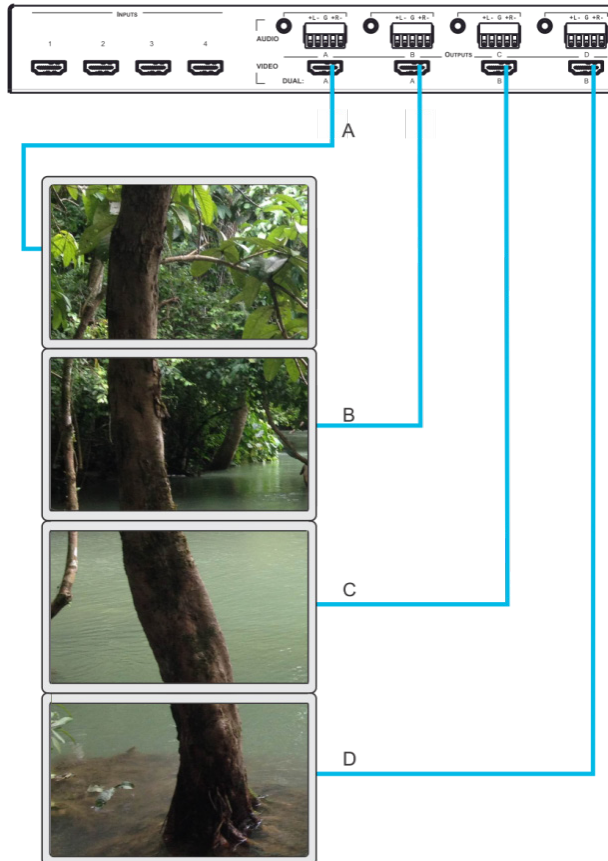

Figure 6: Connecting the VSM-4x4A in 1x4 Video Wall Operation Mode

5.2.2 Operating the VSM-4x4A in Video Wall Mode

To select the inputs via the front panel buttons/IR remote control transmitter:

1. Press **VIDEO WALL** on the front panel to select the Video Wall operation mode.
2. Press **MENU** on the front panel to open the OSD menu (see [Section 6.2](#)) and define the video wall setup (2x2 or 1x4).
3. Press an input button (1 to 4) to switch to the output.

5.2.3 Bezel Correction

Set bezel correction via the OUTPUT menu (see [Section 6.2.1](#)) to make up for the rims around the displays used for creating the video wall, thus creating one smooth picture. In the example in [Figure 7](#) the top photo shows the video wall before bezel correction and the lower photo shows the corrected image on the video wall.

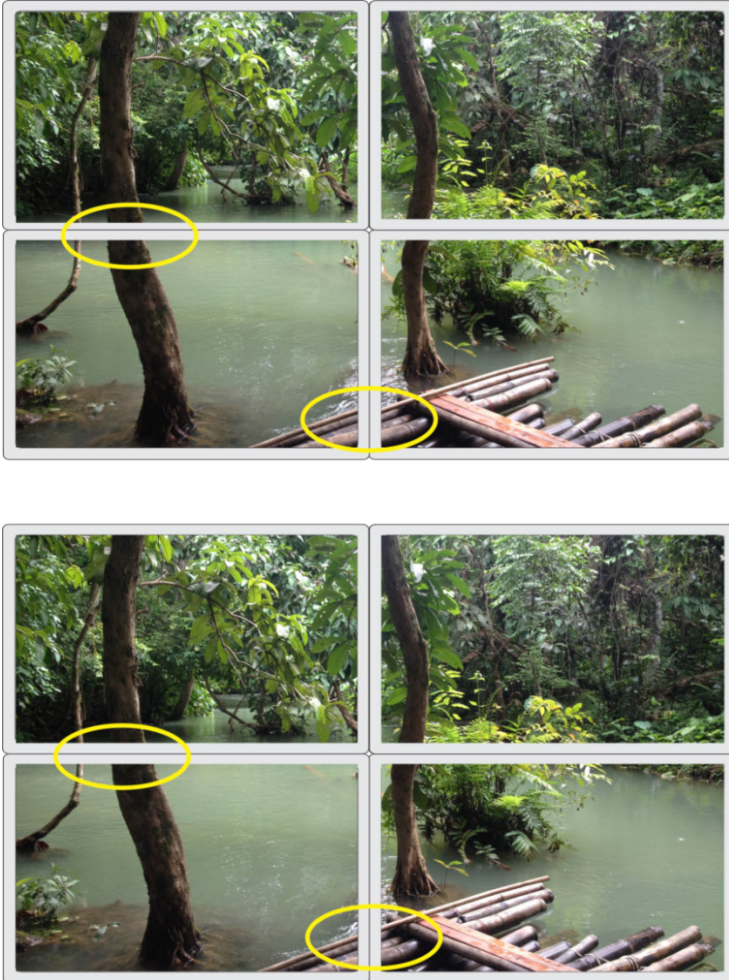

Figure 7: VSM-4x4A Bezel Correction

5.3 Dual Mode

In Dual mode, **VSM-4x4A** is set as a 4x2 switcher with picture-in-picture capabilities that outputs two identical A outputs and two identical B outputs (see [Figure 8](#)).

The dual outputs display any two selected input signals together on one screen. You can set the Dual mode to POP (side-by-side) or PIP (picture-in-picture) configurations.

5.3.1 Connecting the VSM-4x4A in Dual Mode

To connect in the Dual mode as illustrated in [Figure 8](#):

1. Connect the inputs (1 to 4) to HDMI sources, not shown in [Figure 8](#).
2. Connect each of the HDMI output connectors (A to D) to separate acceptors (for example, displays).
3. Connect the power cord.
4. If required, connect:
 - A PC via RS-232, see [Section 6.3](#)
 - The ETHERNET port, see [Section 6.4](#)



In the following example, “Show” is selected in the BORDER menu item (see [Section 6.2.1](#)) to display all the borders.

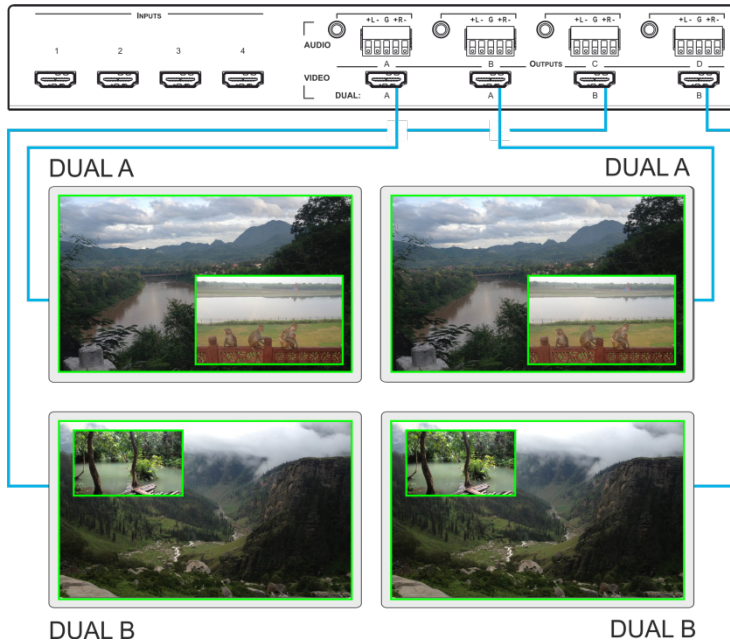

Figure 8: Connecting the VSM-4x4A in Dual Operation Mode

5.3.2 Operating the VSM-4x4A in Dual Mode

To select the inputs via the front panel buttons/IR remote control transmitter:

1. Press **DUAL** on the front panel to select the Dual operation mode.
2. Press one of the dual output buttons:
 - For the A outputs, press **A** or **B**
 - For the B outputs, press **C** or **D**
3. Press any two input buttons in sequence:
 - In the POP mode, the first press is assigned to the LEFT image and the second press is assigned to the RIGHT image
 - in the PIP mode, the first press is assigned to the MAIN image and the second press is assigned to the PIP image

5.4 Quad Mode

The Quad mode shows any four inputs on one screen (each quarter of a screen can show any selected input) and outputs it identically to all four outputs (OUTPUT A to OUTPUT D). [Figure 9](#) shows the order in which the outputs are set in the QUAD mode (this order cannot be configured):

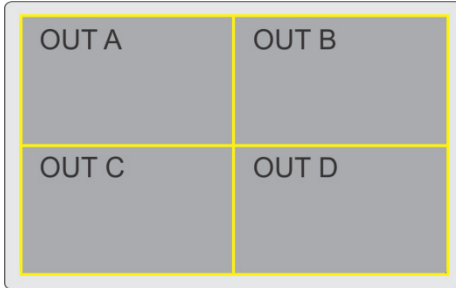

Figure 9: the VSM-4x4A QUAD Operation Mode Input Orientation

5.4.1 Connecting the VSM-4x4A in Quad Mode

To connect the VSM-4x4A in Quad mode as illustrated in [Figure 10](#):

1. Connect an HDMI source to up to four inputs, not shown in [Figure 10](#).
2. Connect the HDMI output connectors OUTPUT A, OUTPUT B, OUTPUT C and OUTPUT D to an HDMI acceptor (for example, to displays).
3. Connect the power cord.

4. If required, connect:

- A PC via RS-232, see [Section 6.3](#)
- The ETHERNET port, see [Section 6.4](#)

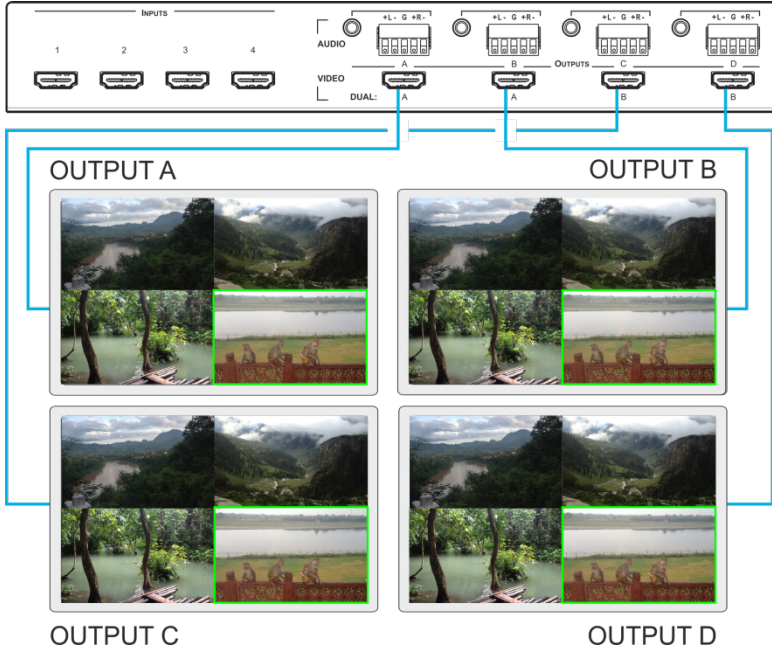

Figure 10: Connecting the VSM-4x4A in Quad Operation Mode



In this example “Only Selected” is selected in the BORDER menu item (see [Section 6.2.1](#)) to display only the border of the selected output.

All four inputs are displayed on each of the output displays.

5.4.2 Operating the VSM-4x4A in Quad Mode

Press **QUAD** on the front panel to operate the **VSM-4x4A** in Quad Mode.

5.5 Wiring the RJ-45 Connectors

This section defines the TP pinout, using a **straight** pin-to-pin cable with RJ-45 connectors.

EIA /TIA 568B	
PIN	Wire Color
1	Orange / White
2	Orange
3	Green / White
4	Blue
5	Blue / White
6	Green
7	Brown / White
8	Brown

Figure 11: TP PINOUT

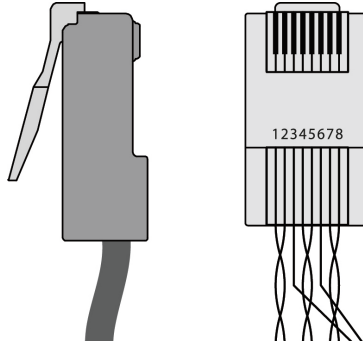

5.6 Connecting the Balanced Stereo Audio Line Output

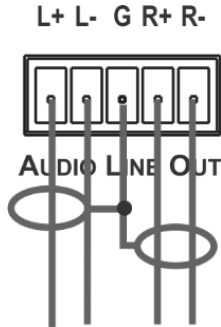

Figure 12: Connecting the Balanced Stereo Audio Output

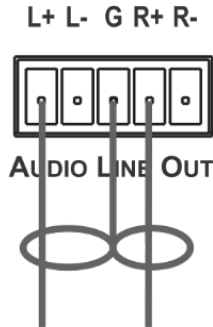

Figure 13: Connecting an Unbalanced Stereo Audio Acceptor to the Balanced Output

6 Controlling the VSM-4x4A

The **VSM-4x4A** can be controlled via:

- Front panel buttons (see [Section 6.1](#))
- OSD menu (see [Section 6.2](#))
- RS-232 serial commands transmitted by a touch screen system, PC, or other serial controller (see [Section 6.3](#))
- The ETHERNET (see [Section 6.4](#)), via the Web pages
- The infrared remote control transmitter (see [Section 6.5](#))

6.1 Controlling via the Front Panel Buttons

VSM-4x4A includes the following front panel buttons:

- Input selector buttons for selecting the required INPUT, HDMI (1 to 4) and OUTPUT/WINDOW selector buttons (A to D)
- ALL (to connect a selected input to all the outputs) and OFF (to disconnect a selected output from the inputs) buttons
- MODE buttons: MATRIX, VIDEO WALL, DUAL and QUAD
- TAKE button
- STO and RCL buttons
- IDENTIFY button to identify the inputs connected to the outputs
- MENU, ENTER, and up, down, left and right arrow buttons for the OSD menu
- RESET TO XGA/720p and PANEL LOCK buttons

6.1.1 Switching Inputs to Outputs

Inputs are routed to outputs differently for each of the four operation modes.



Incomplete operations on the **VSM-4x4A** timeout after 15 seconds.

Matrix Mode

To switch an input to an output in Matrix mode:

1. Press the required OUTPUT/WINDOW button (A to D).
The selected button illuminates.
2. Press an INPUT button (1 to 4) to select the input to switch to the output.

You can also switch several inputs and outputs using the TAKE button (see [Section 6.1.2](#)).

Video Wall Mode (2x2 or 1x4)

To switch an input to the output, press an INPUT button (1 to 4). The selected image appears on the video wall.

The audio input signal is routed to one of the four displays.

Dual Mode

POP Mode: select the inputs to switch to the LEFT and RIGHT images for each of the two dual groups (two A outputs and two B outputs).

PIP Mode: select the INPUT buttons (1 to 4) to switch to the MAIN and PIP images for each of the two dual groups (two A outputs and two B outputs).

To select the images for group A (POP/PIP) using the front panel buttons:

1. Press OUTPUT A or OUTPUT B.
The selected button illuminates.
2. Press an INPUT button (from 1 to 4) to select the left/main image on the output.
3. Press an INPUT button (from 1 to 4) to select the right/PIP image on the output.

To select the images for group B (POP/PIP) using the front panel buttons:

1. Press OUTPUT C or OUTPUT D.
The selected button illuminates.
2. Press an INPUT button (from 1 to 4) to select the left/main image on the output.
3. Press an INPUT button (from 1 to 4) to select the right/PIP image on the output.

The audio signal of the input selected first (the left/main image) will be routed to the output.

Quad Mode

In Quad mode there are no input/output switching operations since all the inputs appear on each output in a preset order.

6.1.1.1 Switching an Input to All the Outputs



This feature is available for all operation modes except the video wall mode.

To switch an input to all the outputs:

1. Press **ALL**.
2. Press an INPUT button (1 to 4) to select the input to switch to all outputs.
The selected input is switched to all outputs.

6.1.1.2 Disconnecting an Input from an Output

To disconnect an input from an output:

1. Press the required OUTPUT button (A to D).
The selected output illuminates.
2. Press **OFF**.
The selected output is disconnected.

6.1.1.3 Disconnecting All the Inputs from the Outputs



This feature is available for all operation modes except the video wall mode.

To disconnect all the inputs from the outputs:

1. Press **ALL**.
2. Press **OFF**.

All the inputs are disconnected from all the outputs.

6.1.2 Using the TAKE Button

You can choose to work in the At Once or the Confirm mode:

- In the At Once mode, pressing an output-input combination implements the action immediately
- In the Confirm mode, pressing the TAKE button activates the switching operation

The At Once Mode

In the At Once mode, execution is immediate and actions require no user confirmation. However, no protection is offered against changing an action in error.

The Confirm Mode

In the Confirm mode:

- You can enter several actions and then confirm them by pressing the TAKE button to simultaneously activate the multiple switches
- Every action requires user confirmation which protects against erroneous switching
- Execution is delayed until the user confirms the action



If the TAKE button is not pressed within 60 seconds, this action is aborted.

6.1.2.1 Toggling between the At Once and Confirm Modes

To toggle between the At Once and Confirm modes:

1. Press **TAKE** to toggle from the At Once mode (TAKE button is not illuminated) to the Confirm mode (TAKE button lights).
Actions now require user confirmation and the TAKE button lights.
2. Press **TAKE** to toggle from the Confirm mode back to the At Once mode.
Actions no longer require user confirmation and the TAKE button no longer lights.

6.1.2.2 Confirming a Switching Action

To confirm a switching action (in the Confirm mode):

1. Press an output-input combination.
The **TAKE** button flashes.
2. Press the flashing **TAKE** button to confirm the action.
The **TAKE** button lights.

To confirm several switching actions (in the Confirm mode):

1. Press each output-input combination in sequence.
The **TAKE** button flashes.
2. Press the flashing **TAKE** button to confirm all the actions.
The **TAKE** button lights.

6.1.3 Storing/Recalling In/Out Configurations

You can store and recall up to four input/output configuration setups via the four INPUT buttons. The stored setups are saved in the non-volatile memory.



Note that you can also store and recall a setup via the OSD menu (see [Section 6.2.1](#)) and the Web pages (see [Section 7](#)).

6.1.3.1 Storing an Input/Output Configuration

To store the current status in memory:

1. Press **STO**.
The **STO** button lights.
2. Press one of the INPUT buttons (1 to 4, this will be the setup # in which the current status is stored). If in the Confirm mode, press the flashing **TAKE** button to confirm the action.
The data is stored to the selected setup number.

6.1.3.2 Recalling an In/Out Configuration

To recall an input/output configuration:

1. Press **RCL**.
The **RCL** button lights.
2. Press the appropriate INPUT button (the button # corresponding to the setup #). If in the Confirm mode, that setup configuration will only be implemented after pressing the TAKE button.
The memory recalls the stored data from that setup.

6.1.4 Front Panel Button Shortcuts

This section defines several front panel button shortcuts:

- **Selecting an audio source** – Press and hold (for 3 seconds) an output (OUTPUT A to OUTPUT D) to select the audio source
- **Muting the audio output** – Press and hold the ALL button (for 3 seconds) to toggle between muting (blocking out the sound) and enabling the audio output

6.2 Using the OSD Menu

Use the front panel control buttons to control the **VSM-4x4A** via the OSD menu.

Press:

- **MENU** to enter the menu
The default timeout is set to 10 seconds
- **ENTER** to accept changes and to change the menu settings
- Arrow buttons to move through the OSD menu, which is displayed on the video output

In the OSD menu, select EXIT to exit the menu.

6.2.1 Configuring the Operation Mode (MODE Menu)

Mode	Function
SEAMLESS MATRIX	Select the 4x4 matrix switcher mode – the same output resolution is set for all the outputs
INDEPENDENT MATRIX	Select the 4x4 matrix switcher mode – each output resolution is set independently
VIDEO WALL 2x2	Select the 2x2 video wall mode
VIDEO WALL 1x4	Select the 1x4 video wall mode  1x4 means 1 column x 4 rows. Note that you cannot rotate the image by 90°. The source should be pan and scan so as to get the correct aspect ratio
DUAL - POP	Select the 4x2 dual POP operation mode: both A outputs display two selected inputs that appear as side by side images identically. In the same way both B outputs display two selected inputs that appear as side by side images identically
DUAL - PIP	Select the 4x2 dual PIP operation mode: both A outputs display two selected inputs that appear as one PIP image over a main screen image, identically. In the same way, both B outputs display two selected inputs that appear as one PIP image over a main screen image, identically
QUAD	Select the QUAD operation mode: All four outputs show all the four input images each of which appears on one quarter of the screen

6.2.2 Configuring Picture Parameters for each Mode (PICTURE Menu)

Mode	Function
Note that the PICTURE menu changes in accordance with the operation mode	
In SEAMLESS MATRIX Mode	For both Matrix modes, set the CONTRAST, BRIGHTNESS, SATURATION and HUE on all the outputs (the settings are the same for all the outputs) RESET ALL the PICTURE parameters to their default values
In INDEPENDENT MATRIX Mode	For both Matrix modes, set the CONTRAST, BRIGHTNESS, SATURATION and HUE separately for OUT A, OUT B, OUT C and OUT D RESET each parameter (CONTRAST, BRIGHTNESS, SATURATION or HUE) for all the outputs. RESET ALL the PICTURE parameters to their default values
In VIDEO WALL Mode	For both Video Wall modes, set the CONTRAST, BRIGHTNESS, SATURATION and HUE separately for OUT A, OUT B, OUT C and OUT D RESET each parameter (CONTRAST, BRIGHTNESS, SATURATION or HUE) for all the outputs RESET ALL the PICTURE parameters to their default values
In DUAL POP Mode	Set the CONTRAST, BRIGHTNESS, SATURATION and HUE separately for the LEFT and RIGHT images of the A outputs, and the LEFT and RIGHT images of B outputs RESET each parameter for all the outputs RESET ALL the PICTURE parameters to their default values
In DUAL PIP Mode	Set the CONTRAST, BRIGHTNESS, SATURATION and HUE separately for the MAIN and PIP images of the A outputs and the MAIN and PIP images of B outputs RESET each parameter for all the outputs RESET ALL the PICTURE parameters to their default values
In QUAD Mode	Set the CONTRAST, BRIGHTNESS, SATURATION and HUE separately for QUAD 1, QUAD 2, QUAD 3 and QUAD 4 RESET each parameter for all the QUADS RESET ALL the PICTURE parameters to their default values

6.2.3 Configuring Output Parameters (OUTPUT Menu)

Mode	Function												
RESOLUTION A to D	<p>Set the output resolution to NATIVE (default), 480p, 576p, 720p50, 720p59, 720p60, 1080p24, 1080p50, 1080p60, 1024x768, 1280x800, 1280x1024, 1366x768, 1440x900, 1600x900, 1680x1050 or 1920x1200</p> <p> The NATIVE resolution is read from OUT A. If the FW cannot detect the OUT A native resolution or if it is not supported, the resolution defaults to 1080p60</p>												
	<table border="1"> <tr> <td>Seamless Matrix mode</td> <td>Set resolution on A Applies to outputs A, B, C and D</td> </tr> <tr> <td>Independent Matrix mode</td> <td>Set resolution separately for A, B, C and D</td> </tr> <tr> <td>Dual PIP mode</td> <td>Set resolution A for dual A (outputs A and B) Set resolution C for dual B (outputs C and D)</td> </tr> <tr> <td>Dual POP mode</td> <td>Set resolution A for dual A (outputs A and B) Set resolution C for dual B (outputs C and D)</td> </tr> <tr> <td>Video wall 4x4, 1x4</td> <td>Set resolution on A. Applies to outputs A, B, C and D</td> </tr> <tr> <td>QUAD mode</td> <td>Set resolution on A. Applies to outputs A, B, C and D</td> </tr> </table>	Seamless Matrix mode	Set resolution on A Applies to outputs A, B, C and D	Independent Matrix mode	Set resolution separately for A, B, C and D	Dual PIP mode	Set resolution A for dual A (outputs A and B) Set resolution C for dual B (outputs C and D)	Dual POP mode	Set resolution A for dual A (outputs A and B) Set resolution C for dual B (outputs C and D)	Video wall 4x4, 1x4	Set resolution on A. Applies to outputs A, B, C and D	QUAD mode	Set resolution on A. Applies to outputs A, B, C and D
Seamless Matrix mode	Set resolution on A Applies to outputs A, B, C and D												
Independent Matrix mode	Set resolution separately for A, B, C and D												
Dual PIP mode	Set resolution A for dual A (outputs A and B) Set resolution C for dual B (outputs C and D)												
Dual POP mode	Set resolution A for dual A (outputs A and B) Set resolution C for dual B (outputs C and D)												
Video wall 4x4, 1x4	Set resolution on A. Applies to outputs A, B, C and D												
QUAD mode	Set resolution on A. Applies to outputs A, B, C and D												
ASPECT RATIO	Set to Full, 4:3, 16:9 or Best Fit(default)												
BORDERS	<p>Available only for the DUAL and QUAD operation modes</p> <p>Set to Show (all the borders), Only Selected (only the selected output, default) or OFF</p> <p>If Show is selected (a border around each image), the selected output's border appears slightly thicker</p>												
BORDER COLOR	Select RED, GREEN (default), BLUE, YELLOW, MAGENTA or GREY												
INPUT LABELS	<p>Set input labels to ON or OFF (default)</p> <p>By default the label is set to Source 1 for input 1, Source 2 for input 2 and so on</p> <p>Note that the labels can be changed via the Web pages or RS-232 commands</p>												
OUTPUT LABELS	<p>Set output labels to ON or OFF (default)</p> <p>By default, labels are set to Output1, Output 2 and so on</p> <p>Note that the labels (up to 12 characters) can be changed via the Web pages or RS-232 commands</p>												
BEZEL CORRECTION	<p>In the Video Wall operation mode, use bezel correction to compensate for the video wall monitor rims which create a non-continuous image across the video wall</p> <p>Set to OFF (default) or ON for the Video Wall operation mode only</p>												
H BEZEL CORRECTION	<p>Set the horizontal bezel correction</p> <p>Note that output resolutions 480p and 576p do not support bezel correction</p>												
V BEZEL CORRECTION	<p>Set the vertical bezel correction</p> <p>Note that output resolutions 480p and 576p do not support bezel correction</p> <p>Note that the 1x4 video wall setup supports V BEZEL correction only</p>												
IDENTIFY	Identify each input/output as well as the audio source (for DUAL and QUAD modes)												

6.2.4 Configuring EDID for each Input (EDID Menu)

Mode	Function
INPUT 1	Set the output from which the EDID is read to input 1: OUT A, OUT B, OUT C, OUT D, Default (default) or FILE
INPUT 2	Set the output from which the EDID is read to input 2: OUT A, OUT B, OUT C, OUT D, Default (default) or FILE
INPUT 3	Set the output from which the EDID is read to input 3: OUT A, OUT B, OUT C, OUT D, Default (default) or FILE
INPUT 4	Set the output from which the EDID is read to input 4: OUT A, OUT B, OUT C, OUT D, Default (default) or FILE
	Note that EDID does not support 4k2k and 3D The FILE option is set from the Web pages (see Section 8.7)
CUSTOM AUDIO EDID	Set the audio format to Disable (audio EDID is not selected when copying an output EDID to an input, default), LPCM 2CH (accepts LPCM 2CH), LPCM 6CH (accepts LPCM 2CH/6CH), LPCM 8CH (accepts LPCM 2CH/6CH/8CH), BITSTREAM ((accepts LPCM 2CH, AC3, DTS) or HD (accepts LPCM 2CH/6CH/8CH, AC3, DTS, Dolby Digital Plus, DTS-HD)

6.2.5 Configuring Source Parameters for each Mode (SOURCE Menu)

Mode	Function
In MATRIX Mode	Set the input source for each of the outputs: From VIDEO OUT A to VIDEO OUT D, select IN 1 (default), IN 2, IN 3 or IN 4 for each The audio source follows the video source
In 2x2 VIDEO WALL Mode	Select the video wall input source (IN1 to IN 4). The audio source follows the video source
In 1x4 VIDEO WALL Mode	Select the video wall input source (IN1 to IN 4). The audio source follows the video source Set CROP/POSITION parameters to ON or OFF Set H CROP to horizontally pan and scan the image (from 0% to 400%) Set H POSITION to set the horizontal position of the image (-999 to 0 to +999). The (-) values indicate a shift to the left. (0) means the center position and (+) indicates a shift to the right
In DUAL POP Mode	Select the input sources for the left and right sides of outputs A and the left and right sides of outputs B: VIDEO OUT A LEFT: IN 1, IN 2, IN 3 or IN 4 VIDEO OUT A RIGHT: IN 1, IN 2, IN 3 or IN 4 VIDEO OUT B LEFT: IN 1, IN 2, IN 3 or IN 4 VIDEO OUT B RIGHT: IN 1, IN 2, IN 3 or IN 4 Set the audio source for outputs A and outputs B (left or right for each set): AUDIO OUT A: LEFT or RIGHT AUDIO OUT B: LEFT or RIGHT

Mode	Function
In DUAL PIP Mode	<p>Select the input sources for the MAIN and PIP sides of outputs A and the MAIN and PIP sides of outputs B:</p> <p>VIDEO OUT A MAIN: IN 1, IN 2, IN 3 or IN 4 VIDEO OUT A PIP: IN 1, IN 2, IN 3 or IN 4 VIDEO OUT B MAIN: IN 1, IN 2, IN 3 or IN 4 VIDEO OUT B PIP: IN 1, IN 2, IN 3 or IN 4</p> <p>Set the audio source for outputs A and outputs B (MAIN or PIP for each set):</p> <p>AUDIO OUT A: MAIN or PIP AUDIO OUT B: MAIN or PIP</p> <p>Set the PIP parameters for outputs A and outputs B separately:</p> <p>PIP A SIZE: SMALL, MEDIUM or LARGE PIP A POSITION: RIGHT TOP, RIGHT BOTTOM, LEFT BOTTOM or LEFT TOP PIP A SWAP: swap the MAIN and PIP images (including the audio signal) PIP B SIZE: SMALL, MEDIUM or LARGE PIP B POSITION: RIGHT TOP, RIGHT BOTTOM, LEFT BOTTOM or LEFT TOP PIP B SWAP: swap the MAIN and PIP images (including the audio signal)</p>
In QUAD Mode	<p>Set the input source for each QUAD:</p> <p>VIDEO QUAD 1: IN 1, IN 2, IN 3 or IN 4 VIDEO QUAD 2: IN 1, IN 2, IN 3 or IN 4 VIDEO QUAD 3: IN 1, IN 2, IN 3 or IN 4 VIDEO QUAD 4: IN 1, IN 2, IN 3 or IN 4</p> <p>Select the AUDIO SOURCE: IN 1, IN 2, IN 3 or IN 4</p>

6.2.6 Storing and Recalling Setups (RECALL/STORE Menu)

Mode	Function
RECALL/STORE	<p>STORE up to four input/output setups and RECALL them (all the parameters are stored excluding the input/output labels and the OSD setup)</p> <p>The stored setups for each memory are also shown (FAV. 1 to FAV. 4)</p> <p>Use STORE to store the current setup to one of the four memories (FAV. 1 to FAV. 4)</p> <p>Use RECALL to select a stored setup</p> <p>NOW (current status) shows the current setup for all four outputs</p>

6.2.7 Configuring HDCP for Inputs and Outputs (HDCP Menu)

Menu Item	Function
INPUT 1 to INPUT 4	Select the HDCP option for the HDMI input: either ON (the default) or OFF: Setting HDCP support to disabled (OFF) on the HDMI input allows the source to transmit a non-HDCP signal if required (for example, when working with a Mac computer)
OUTPUT A to OUTPUT D	Select FOLLOW INPUT or FOLLOW OUTPUT to define whether the HDCP will follow the input or the output When FOLLOW INPUT is selected, it changes its HDCP output setting (for the HDMI output) according to the HDCP of the input. This option is recommended when the HDMI output is connected to a splitter/switcher When FOLLOW OUTPUT is selected, the scaler matches its HDCP output to the HDCP setting of the HDMI acceptor to which it is connected

6.2.8 Configuring Analog Audio Level (VOLUME Menu)

Menu Item	Function
ANALOG OUTPUT A	Set OUTPUT A volume
ANALOG OUTPUT B	Set OUTPUT B volume
ANALOG OUTPUT C	Set OUTPUT C volume
ANALOG OUTPUT D	Set OUTPUT D volume
The default volume level is for a 0 dB volume gain (the output volume is the same as the input volume)	

6.2.9 Configuring Ethernet Parameters (ETHERNET Menu)

Menu Item	Function
IP MODE	Set to DHCP or STATIC
STATIC SET	Set to IP number, netmask or gateway to change their numerals
BYTE (1 to 4)	Set the IP, MASK and GATE addresses via these 4 bytes By default: IP = 192.168.1.39; Gateway = 192.168.1.254; and Netmask = 255.255.255.0 NOW shows the current link status and the current IP, MASK and GATE addresses

6.2.10 Configuring OSD Parameters (OSD SETTINGS Menu)

Mode	Function
POSITION	Set the position of the OSD to LEFT TOP, RIGHT TOP, LEFT BOTTOM or RIGHT BOTTOM
H OFFSET	Shift the horizontal position of the OSD
V OFFSET	Shift the vertical position of the OSD
VIDEO WALL OSD	Set to Single Output to have the OSD appear on one of the video wall outputs or set to All Outputs to have the OSD appear on all four outputs.
TRANSPARENCY	Set the OSD background between 9 (opaque) and 0 (transparent)
IDENT. TIMEOUT	Set the "Identify" label timeout period in seconds or set it to OFF so it will appear continuously
MENU TIMEOUT	Set the menu timeout period in seconds or set it to OFF so it will appear continuously
INFO. TIMEOUT	Set the "INFO" display timeout period in seconds or set it to OFF so it will appear continuously
INFO. DISPLAY	Set the display of information ON or OFF
BRIEF INFO.	Set the display of brief information ON or OFF
VOLUME INFO.	Set the display of volume information ON or OFF
EXIT	Click to exit this menu

6.2.11 Configuring Power Saving Settings (ADVANCED > AUTO SYNC OFF Menu)

Turn the auto sync off to DISABLE (default), FAST or SLOW. This feature is useful, for example, when the output is connected to a projector, and the projector automatically shuts down when it has no input.

Mode	Function
DISABLE	The power save mode is disabled
FAST	Auto sync off is enabled, and the output is de-activated after 10 seconds if no input is present
SLOW	Auto sync off is enabled, and the output is de-activated after 2 minutes if no input is present

6.2.12 Configuring Lock Mode (ADVANCED > LOCK MODE Menu)

Mode	Function
ALL	Lock all the front panel buttons
MENU ONLY	Lock the MENU (and navigation) front panel buttons only
ALL & SAVE	Lock all the front panel buttons The lock status is saved when the VSM-4x4A is powered down
MENU ONLY & SAVE	Lock the MENU (and navigation) front panel buttons only The lock status is saved when the VSM-4x4A is powered down

6.2.13 Upgrading Firmware (ADVANCED > FW USB UPGRADE Menu)

Select ON to enable firmware upgrade via the USB port or OFF (default) to disable firmware upgrade. Press [MENU] or [ESC] to abort upgrade.



See [Section 7](#) for firmware upgrade instructions.

6.2.14 Resetting to Factory Default Settings (FACTORY DEFAULT Menu)

Select NO or YES to reset to the factory default parameters (including the Ethernet parameters).

6.2.15 Viewing Device Status (INFORMATION Menu)

The INFORMATION menu shows the:

- Source HDCP
- Source audio format (if there is no audio-shows MUTE)
- Input and output resolutions
- OUT A, B, C and D native resolutions
- OUT mode
- Firmware version
- Kramer logo

6.3 Connecting to the VSM-4x4A via RS-232

You can connect to the **VSM-4x4A** via an RS-232 connection using, for example, a PC. Note that a null-modem adapter/connection is not required.

To connect to the **VSM-4x4A** via RS-232, connect the RS-232 9-pin D-sub rear panel port on the product unit via a 9-wire straight cable (only pin 2 to pin 2, pin 3 to pin 3, and pin 5 to pin 5 need to be connected) to the RS-232 9-pin D-sub port on your PC.

6.4 Operating the VSM-4x4A via Ethernet

You can connect to the **VSM-4x4A** via Ethernet using either of the following methods:

- Directly to the PC using a crossover cable (see [Section 6.4.1](#))
- Via a network hub, switch, or router, using a straight-through cable (see [Section 6.4.2](#))

Note: If you want to connect via a router and your IT system is based on IPv6, speak to your IT department for specific installation instructions.

6.4.1 Connecting the Ethernet Port Directly to a PC

You can connect the Ethernet port of the **VSM-4x4A** directly to the Ethernet port on your PC using a crossover cable with RJ-45 connectors.



This type of connection is recommended for identifying the **VSM-4x4A** with the factory configured default IP address.

After connecting the **VSM-4x4A** to the Ethernet port, configure your PC as follows:

1. Click **Start > Control Panel > Network and Sharing Center**.
2. Click **Change Adapter Settings**.
3. Highlight the network adapter you want to use to connect to the device and click **Change settings of this connection**.

The Local Area Connection Properties window for the selected network adapter appears as shown in [Figure 14](#).

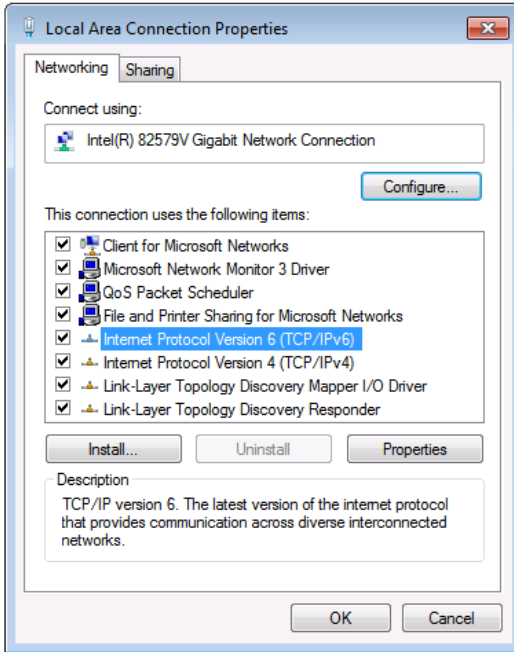

Figure 14: Local Area Connection Properties Window

4. Highlight either **Internet Protocol Version 6 (TCP/IPv6)** or **Internet Protocol Version 4 (TCP/IPv4)** depending on the requirements of your IT system.
5. Click **Properties**.
The Internet Protocol Properties window relevant to your IT system appears as shown in [Figure 15](#) or [Figure 16](#).

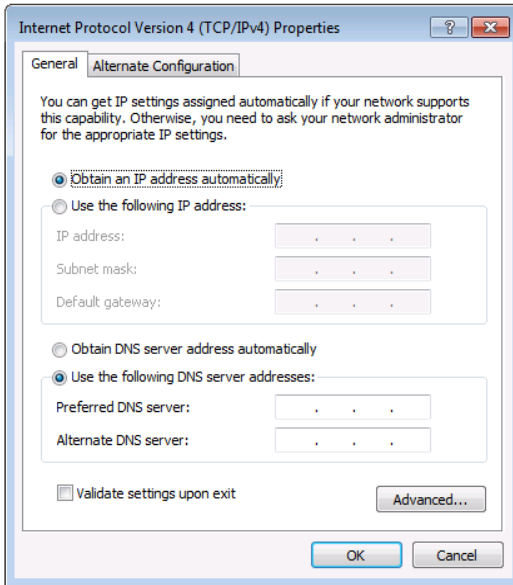

Figure 15: Internet Protocol Version 4 Properties Window



Figure 16: Internet Protocol Version 6 Properties Window

6. Select **Use the following IP Address** for static IP addressing and fill in the details as shown in [Figure 17](#).

For TCP/IPv4 you can use any IP address in the range 192.168.1.1 to 192.168.1.255 (excluding 192.168.1.39) that is provided by your IT department.

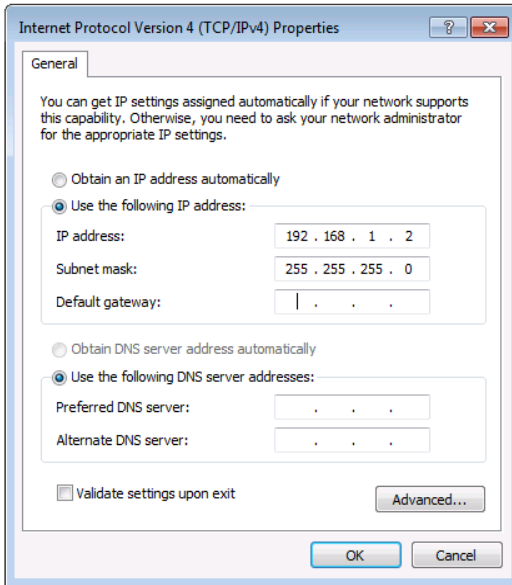

Figure 17: Internet Protocol Properties Window

7. Click **OK**.
8. Click **Close**.

6.4.2 Connecting the Ethernet Port via a Network Hub or Switch

You can connect the Ethernet port of the **VSM-4x4A** to the Ethernet port on a network hub or using a straight-through cable with RJ-45 connectors.

6.4.3 Configuring the Ethernet Port

You can set the Ethernet parameters via the embedded Web pages (see [Section 8.3.1](#)).

6.5 Controlling via the IR Remote Control

You can control the **VSM-4x4A** from the infrared remote control transmitter:

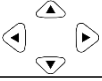

Figure 18: Infrared Remote Control Transmitter

Keys	Function
POWER	Toggle the power save mode ON or OFF
IDENTIFY	Identify the inputs on each output
INFO	Indicate on each output, which input is displayed on the output
MUTE	Toggle between muting (blocking out the sound) and enabling the audio output
MATRIX	Set to Matrix mode (see Section 5.1)
VID WALL	Set to video wall mode (see Section 5.2)
DUAL	Set to dual mode (see Section 5.3)
QUAD	Set to quad mode (see Section 5.4)
STO	Store a configuration
RCL	Recall a configuration
	Four navigation keys
OK	Accept changes
MENU	Enter the OSD menu
ESC	EXIT the menu
ALL	Select all the outputs
OFF	Disconnect a selected input
TAKE	Carry out a setup
OUT	Select an output (A to D)
IN	Select an input (1 to 4)
AUDIO	Select the audio source (1 to 4) For Dual and Quad modes only
1080p Reset	Reset the resolution to 1080p
XGA Reset	Reset the resolution to XGA
Panel Lock	Lock/unlock the front panel buttons

6.6 Using the IR Remote Control in Dual Mode

This section describes how to use the IR remote control transmitter in the DUAL operation mode.

6.6.1 Using the Transmitter in Dual Mode (1)

When in Dual operation mode, you can use the IR remote control transmitter shortcuts to perform additional actions. [Figure 19](#) shows the remote control with dual mode operation instructions. Note that these instructions are further detailed in the following pages.

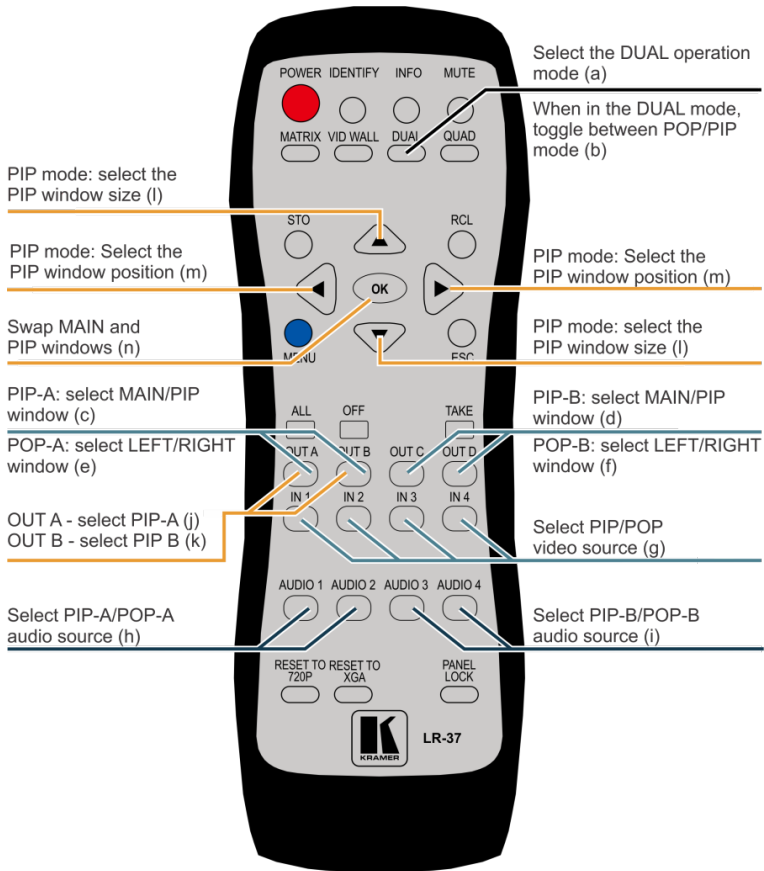

Figure 19: IR Remote Control Transmitter Dual Mode Shortcuts



Note that the letters that appear in brackets in the following pages refer to the same letters that appear in brackets in [Figure 19](#).

To use the Dual mode shortcuts:

1. Press the DUAL button to select the DUAL operation button **(c)**.
2. Press the DUAL button again to select the PIP or POP mode **(d)**.

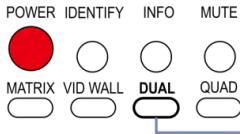

1. Press the DUAL Button to select the DUAL operation mode.
2. Press the DUAL button again to select the PIP or POP mode.

To select the inputs to switch to the outputs:

1. Select an output:
 - PIP A: press OUT A/OUT B to select the Main/PIP window for A **(e)**
 - PIP B: press OUT B/OUT C to select the Main/PIP window for B **(f)**
 - POP A: press OUT A/OUT B to select the Left/Right window for A **(e)**
 - POP B: press OUT C/OUT D to select the Left/Right window for B **(f)**
2. Select the input to switch to the output:
 - Press one of the inputs (IN 1 to IN 4) to switch to the selected output **(g)**

For PIP/POP A:

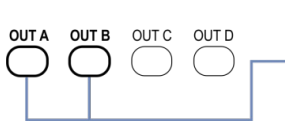

- PIP A: Press OUT A/OUT B to select the Main/PIP window for A.
 POP A: Press OUT A/OUT B to select the Left/Right window for A.

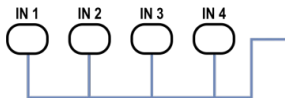

Press an input (from IN 1 to IN 4) to switch to the output

For PIP/POP B:

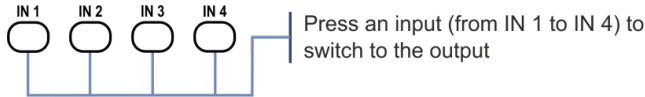
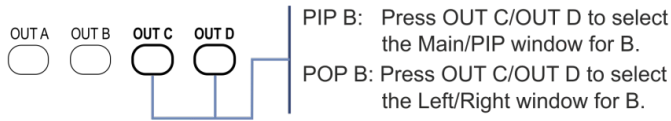

To set the audio source:

- PIP A: press AUDIO 1/AUDIO 2 to select the Main/PIP audio source for A (**h**)
- PIP B: press the AUDIO 3/AUDIO 4 to select the Main/PIP audio source for B (**i**)
- POP A: press AUDIO 1/AUDIO 2 to select the Left/Right audio source for A (**h**)
- POP B: press the AUDIO 3/AUDIO 4 to select the Left/Right audio source for B (**i**)

For PIP/POP A:

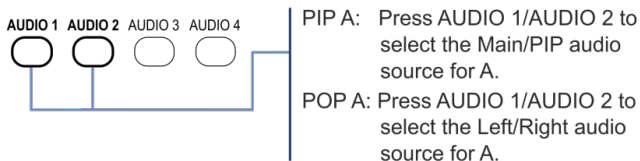

For PIP/POP B:

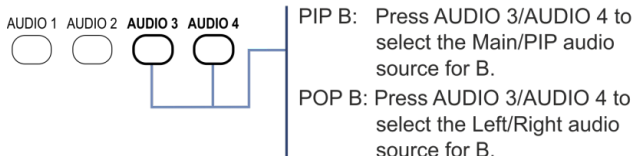

To perform various PIP mode operations:

1. Make sure you are in the PIP mode.
2. Select the PIP output:
 - Press OUT A to select PIP A **(j)**
 - Press OUT B to select PIP B **(k)**
3. Perform any of the following operations.
 - Press up/down arrow to select the PIP window size **(l)**

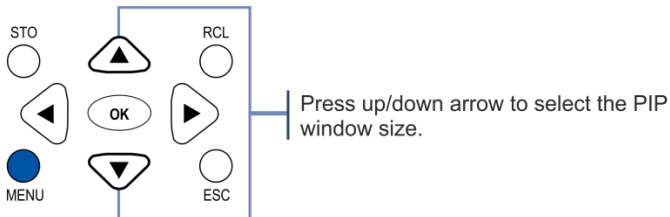

- Press the left/right arrow to select the PIP window position **(m)**

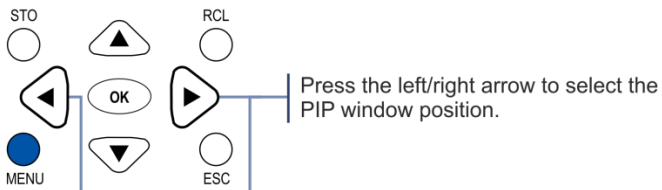

- Press the OK button to swap between main and PIP windows **(n)**

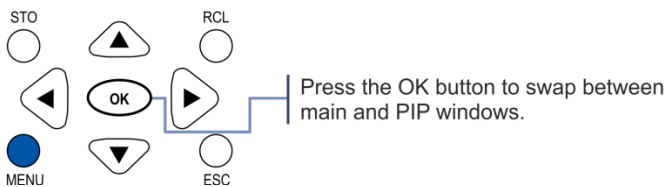

7 Firmware Upgrade

You can upgrade the **VSM-4x4A** via the USB port on the rear panel or via the Device Settings web pages (see [Section 8.3.2](#)).



The latest firmware version can be downloaded from the Kramer Web site at www.kramerav.com/downloads/VSM-4x4A.

To upgrade the firmware via the USB port:

1. Download the **VSM-4X4A_vx.xx.BIN** firmware and copy it to the root folder of a memory stick, formatted with FAT32 system.
2. Disconnect the power from the **VSM-4x4A**.
3. Connect the memory stick to the USB port on the rear panel of the **VSM-4x4A**.
4. Power the **VSM-4x4A**.
5. Press **MENU** on the front panel of the device.
6. Select **ADVANCED>FIRMWARE USB UPGRADE>ON**.
7. Press **ENTER**.
8. Wait until the device restarts following the upgrade process.
9. Disconnect the memory stick.
10. Perform factory reset.
11. Check that the firmware was updated.

8 Using the Embedded Web Pages

The Web pages let you control the **VSM-4x4A** via the Ethernet. The Web pages include all the OSD items and more, and are accessed using a Web browser and an Ethernet connection.

Before attempting to connect:

- Perform the procedures in [Section 6.4](#)
- Ensure that your browser is supported

The following operating systems and Web browsers are supported:

OS	Version	Browser	Version
Windows	Up to Windows 10	IE	11
		FireFox	47
		Chrome	50
Mac		Chrome	51
iOS		Safari	9.1.1
		Chrome	45
Android		Chrome	51

8.1 Browsing the VSM-4x4A Web Pages

To browse the **VSM-4x4A** Web pages:

1. Open your Internet browser.
2. Type the IP address of the device in the Address bar of your browser. For example, the default IP address:



The Routing & Scaling (first) page loads (see [Figure 20](#)).

The list of Web pages appears to the left of each page. Click a page from the list to open it. **VSM-4x4A** includes seven Web pages:

- The Routing & Scaling page (see [Section 8.2](#))
- The Device settings page (See [Section 8.3](#))
- The Output settings page (see [Section 8.4](#))
- The Audio settings page (see [Section 8.5](#))
- The HDCP settings page (see [Section 8.6](#))
- The EDID management page (see [Section 8.7](#))
- The About page (see [Section 8.8](#))

8.2 Routing & Scaling Page

[Figure 20](#) shows the Routing & Scaling page that is also the first page that appears following the loading page. The routing page includes a tab for each of the four operation modes.

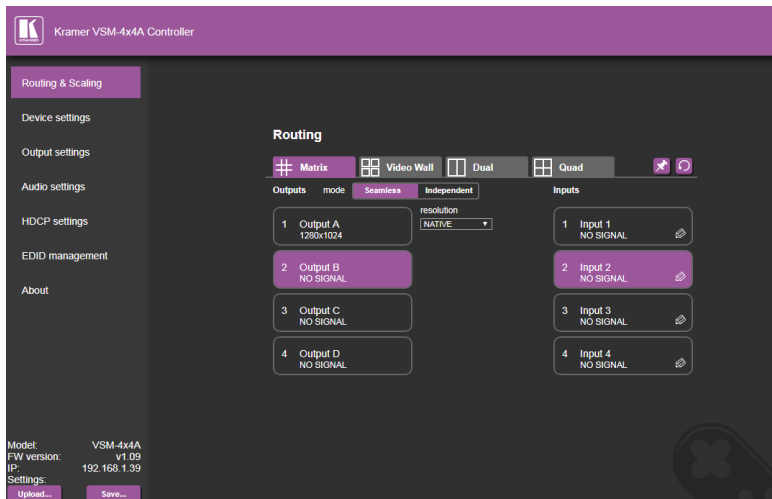

Figure 20: The Routing & Scaling Page

Click **Upload / Save** on the lower part of the screen to upload a saved configuration / save a configuration (see [Section 8.9](#)). The model name, FW version and IP number appear on the lower left side.

The Routing & Scaling page lets you route the input/s to the outputs in each of the operation modes as follows for the:

- Matrix mode, see [Section 8.2.1](#)
- Video Wall mode, see [Section 8.2.2](#)
- Dual Mode, see [Section 8.2.3](#)
- Quad mode, see [Section 8.2.4](#)

8.2.1 Matrix Operation Mode

Click **Matrix** to display the Matrix mode window. In the Matrix mode, switch inputs 1 to 4 to any or all the outputs.

Select one of the following switching configurations:

- Click **Seamless** for zero-time switching (resolution on all the outputs is the same) and select the resolution from the drop-down list

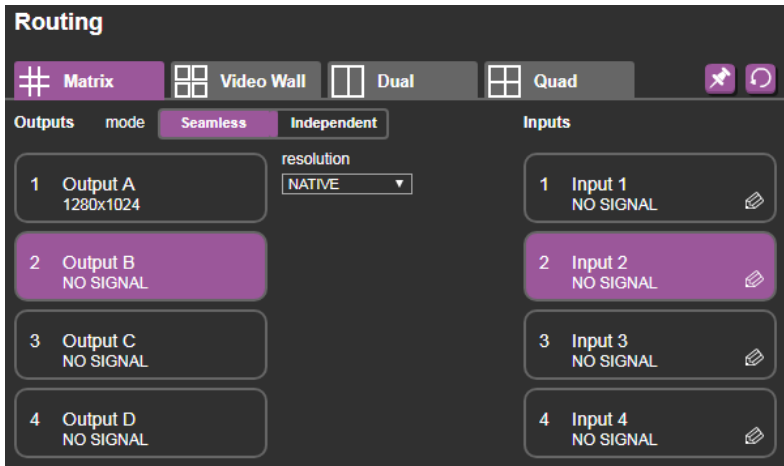

Figure 21: The Matrix Tab output Resolution (Seamless Mode)

- Click **Independent** for fade-through-black switching (enabling independent resolutions on each output) and select the resolution on each output from the drop-down list

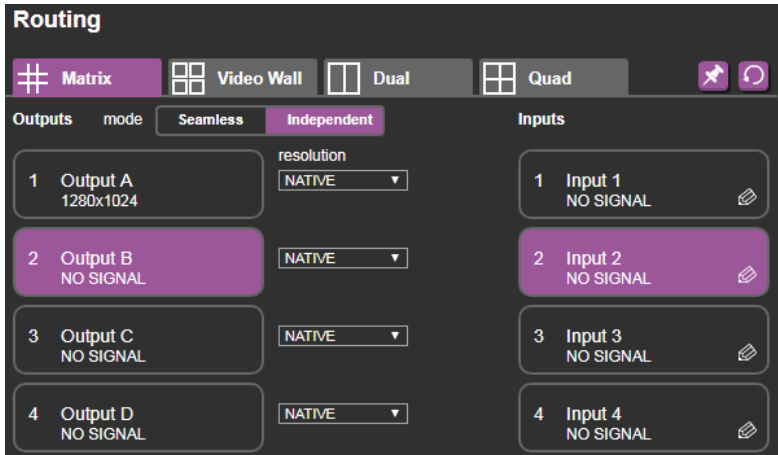

Figure 22: Matrix Tab output Resolution (Independent Mode)

The Output buttons show the resolution and the input buttons show the signal type (or NO SIGNAL in this example).

To switch an Input to an Output in the Matrix Mode:

1. Click an output.
2. Click an input button to switch to that output.

8.2.2 Video Wall Operation Mode

Click **Video Wall** to display the Video Wall mode window and select either a 2x2 (see [Figure 23](#)) or a 1x4 (see [Figure 24](#)) wall:

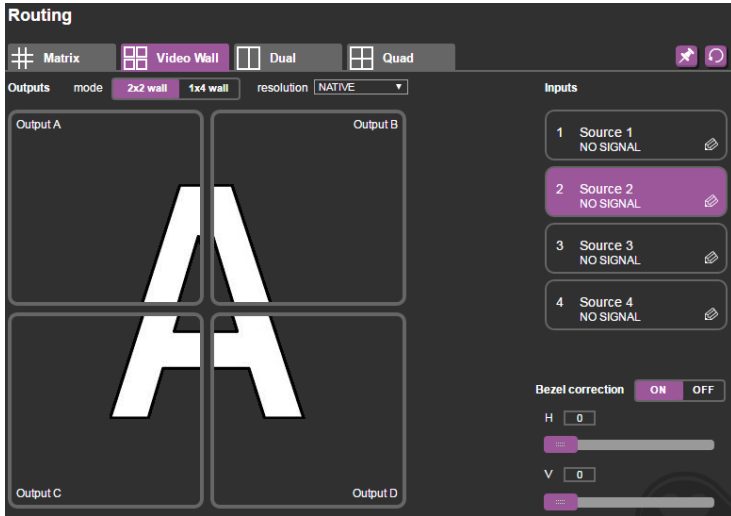

Figure 23: 2x2 Video Wall Tab

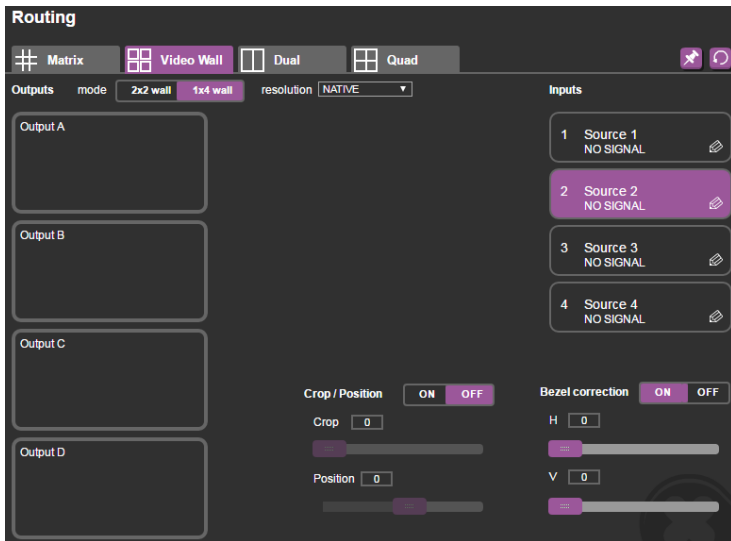

Figure 24: 1x4 Video Wall Tab

The video wall tab displays four outputs in a video wall display (2x2 or 1x4, selectable). Click one of the four input buttons to switch an input to the video wall. You can edit the input label (see [Section 8.2.5.1](#)), store and recall a video wall configuration (see [Section 8.2.5](#)) and set the output resolution.

8.2.2.1 Bezel Correction

Set the horizontal and vertical bezel correction (see [Section 5.2](#)) via the Video Wall tab:

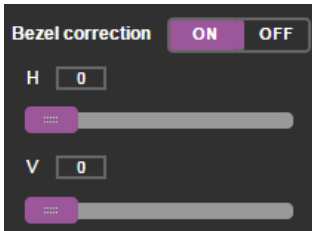

Figure 25: The Video Wall Tab – Bezel Correction

8.2.2.2 Crop and Position the Image

Crop and/or position the image on the 1x4 video wall (see [Section 5.2](#)) via the Video Wall tab:

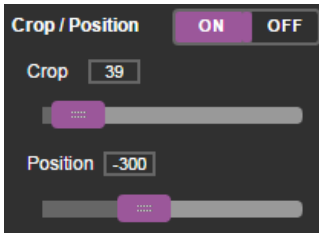

Figure 26: The Video Wall Tab – Crop/Position Correction

8.2.3 Dual Operation Mode

Click **Dual** to display the Dual mode window and set **Mode** to one of the following configurations:

- POP – Side-by-side images on the output (Left and Right)

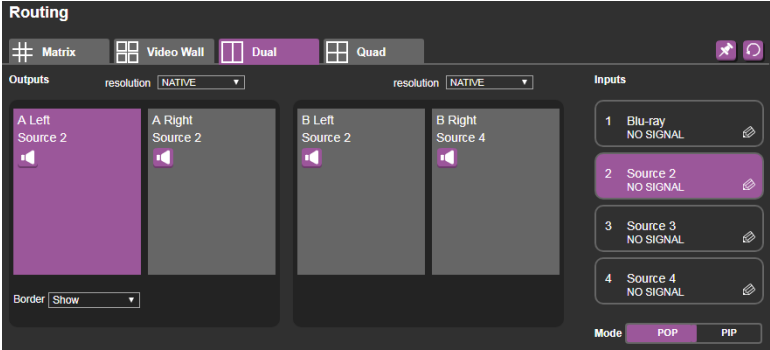

Figure 27: The Dual Tab – POP Mode

- PIP – A PIP image over the main image on the output

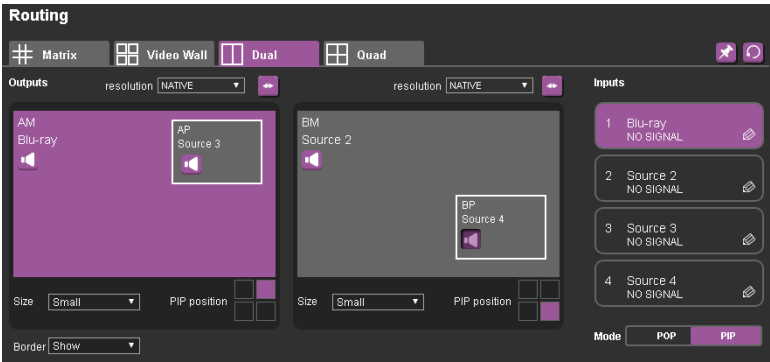

Figure 28: The Dual Tab – PIP Mode

In the DUAL mode you can perform the following operations:

- Switch an input to an output – see [Section 8.2.3.1](#)
- Set the borders of an image to Show, Only Selected or Off
- Edit the input label (see [Section 8.2.5.1](#))
- Store and recall a setup (see [Section 8.2.5](#))
- Set the output resolution separately for A and B via the resolution drop-down box
- Select the audio source
- In the PIP mode, click a **PIP position** box to set the PIP location (top left, top right, lower left or lower right) and the PIP **Size** drop-down box (Large, Medium, Small or Off)

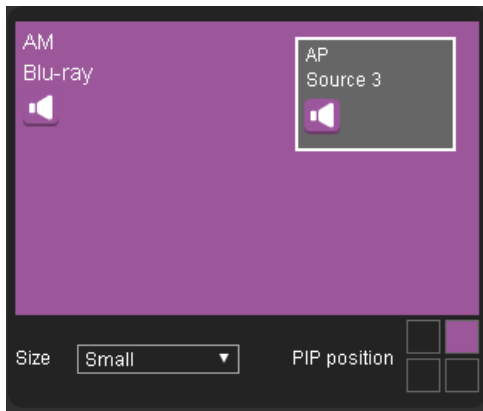

Figure 29: The Dual Tab – PIP Position and Size

8.2.3.1 Switching an Input to an Output

To switch an input to an output:

- For POP: select the Left or Right on the A or B outputs
- For PIP: select the MAIN or PIP on the A or B outputs

Click an input button to switch to the output.

8.2.4 Quad Mode

Click **Quad** to display the Quad mode window.

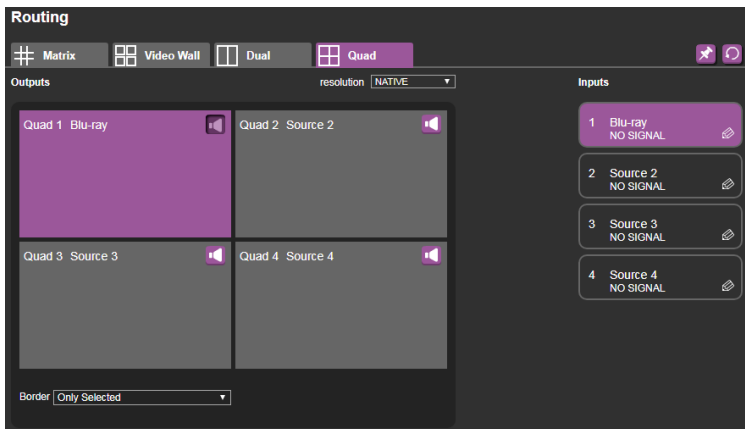

Figure 30: The Quad Tab

You can perform the following operations:

- Switch an input to an output – Click one of the 4 images (outputs) and then click an input to switch to the selected output
- Edit the input label (see [Section 8.2.5.1](#))
- Store and recall a configuration (see [Section 8.2.5](#))
- Set the borders of an image to Show, Only Selected or Off
- Set the output resolution via the resolution drop-down box

8.2.5 Storing and Recalling a Configuration

Click the Store button  to store a configuration:



Figure 31: The Matrix Tab – Store a Configuration

1. Select one of the four presets.
The configuration is saved.



Click the Recall button  to recall a configuration:



Figure 32: The Matrix Tab – Recall a Configuration

2. Select one of the four presets.
The configuration is uploaded.

Click the  icon to exit the preset window.

8.2.5.1 Editing the Input Window

Click the edit icon  to edit the input button. This window lets you edit the input label:



Figure 33: Matrix Tab – Input Edit Window

Type a label name (for example, Blu-ray):

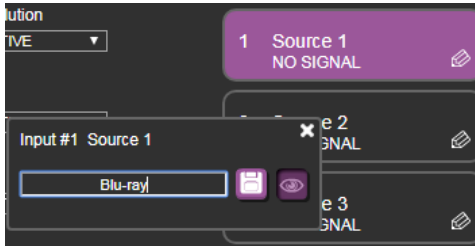

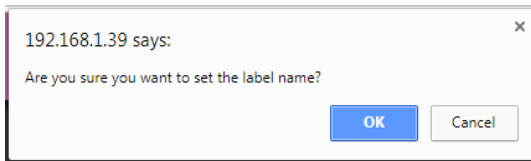



Figure 34: The Matrix Tab – Typing the New Label

Click  to save the new Label. The following message appears:



Click **OK** to save the label name.

Toggle  /  to view the label in the Web pages:

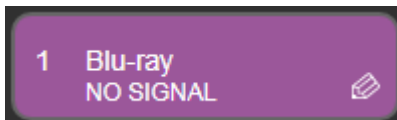



Figure 35: The Matrix Tab – Viewing the Label

Click  to exit the input editing window.

8.3 Device Settings Page

In the navigation pane, select **Device settings** to access the Output Settings page. The Device Settings page (in [Figure 36](#)) displays the firmware version and lets you set the Ethernet parameters, perform a factory reset and show the information window.

Device Settings

Model: VSM-4x4A
MAC address: 00-1D-56-03-80-C0
Firmware Version: 1.09

DHCP On

DHCP IP Address:

Static IP Address:

Subnet:

Gateway:

UDP Port:

TCP Port:

Firmware Upgrade

Figure 36: The Device Settings Page

8.3.1 Changing Ethernet Settings

You can change the Ethernet parameters by typing the changing and clicking the Set changes button.



When changing the IP address, the change is immediate and the Web page reloads with the new IP address (see [Figure 38](#)).

The screenshot shows a dark-themed web interface titled "Device Settings". It displays several configuration fields: Model (VSM-4x4A), MAC address (00-11-22-AA-BB-CC), and Firmware Version (1.02). Below these is a section for DHCP settings, with a checkbox labeled "DHCP On" that is currently unchecked. Underneath are input fields for IP Address (192.168.1.40), Subnet (255.255.0.0), Gateway (192.168.1.254), UDP Port (50000), and TCP Port (23). At the bottom, there is a "Firmware Upgrade" section with a "Choose a file" label, a "Browse..." button, and a "Start Upgrade" button. In the bottom left corner, there is a "Factory reset" button, and in the bottom right corner, there is a "Set changes" button next to an information icon.

Figure 37: The Device Settings Page – Ethernet Settings

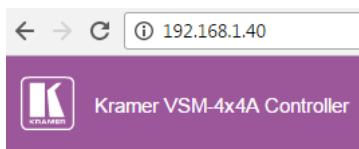
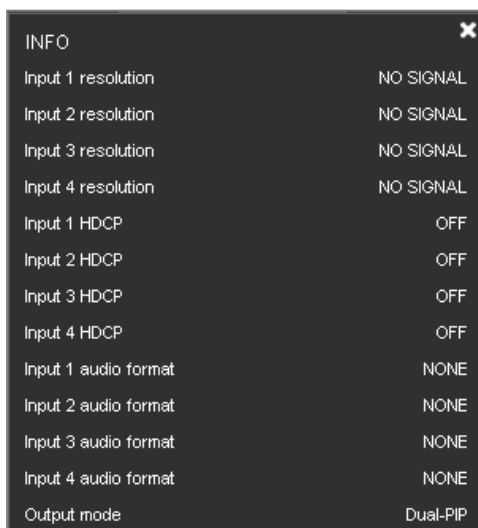

Figure 38: The Device Settings Page – IP Number Settings

To view the device information, click the  icon on the lower right side of the page.



The image shows a dark-themed information window titled 'INFO' with a close button (X) in the top right corner. The window contains a list of device settings and their current values.

Input 1 resolution	NO SIGNAL
Input 2 resolution	NO SIGNAL
Input 3 resolution	NO SIGNAL
Input 4 resolution	NO SIGNAL
Input 1 HDCP	OFF
Input 2 HDCP	OFF
Input 3 HDCP	OFF
Input 4 HDCP	OFF
Input 1 audio format	NONE
Input 2 audio format	NONE
Input 3 audio format	NONE
Input 4 audio format	NONE
Output mode	Dual-PIP

Figure 39: Device Settings Page – Information Window

8.3.2 Upgrading Firmware

To upgrade the firmware:

1. Click **Browse** and select the file.

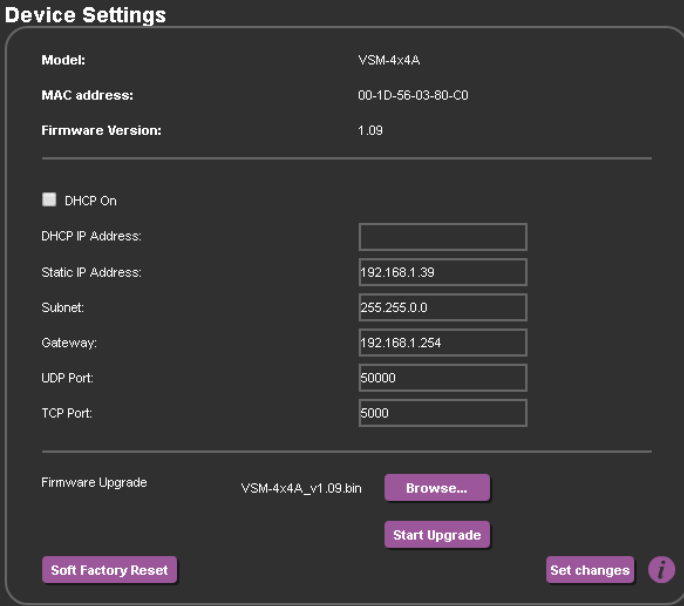

The screenshot shows the 'Device Settings' page for a VSM-4x4A device. The page is dark-themed and contains the following information:

- Model:** VSM-4x4A
- MAC address:** 00-1D-56-03-80-C0
- Firmware Version:** 1.09

DHCP On

DHCP IP Address:

Static IP Address:

Subnet:

Gateway:

UDP Port:

TCP Port:

Firmware Upgrade: VSM-4x4A_v1.09.bin

Figure 40: Device Settings Page – Uploading the Firmware File

2. Click **Start Upgrade**. The following window appears:

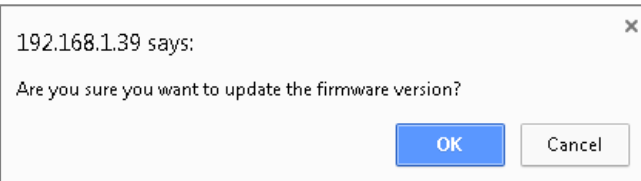

The screenshot shows a confirmation dialog box with the following text:

192.168.1.39 says:

Are you sure you want to update the firmware version?

Figure 41: Device Settings Page – Firmware Upgrade Message

3. Click **OK** and wait for firmware upgrade completion.

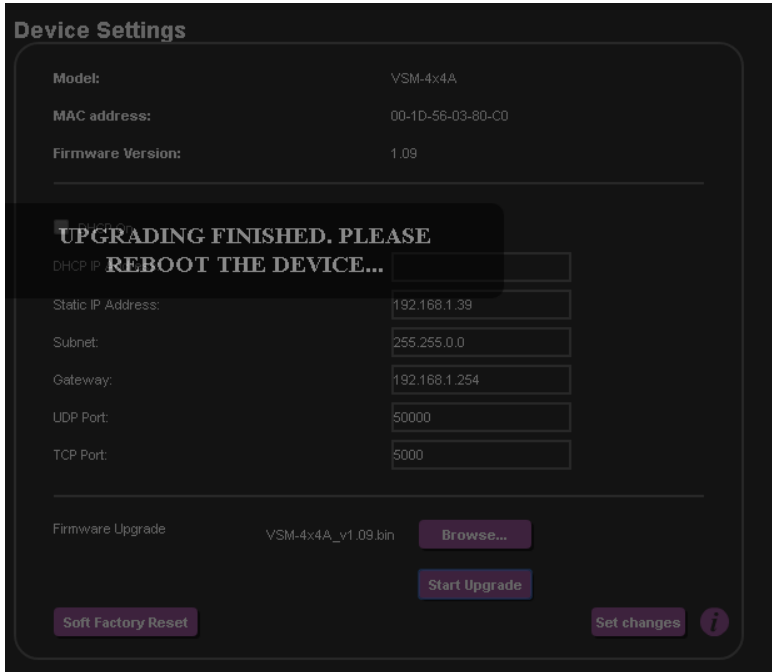

Figure 42: Device Settings Page – Firmware Upgrade Complete

4. Reboot the device and then refresh the Web page.

8.3.3 Factory Reset

Click **Soft Factory Reset** to reset the device. The following message appears:

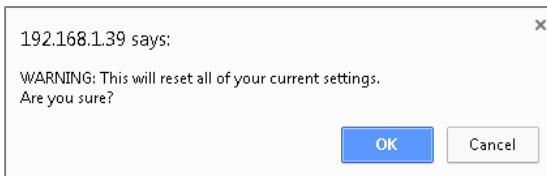
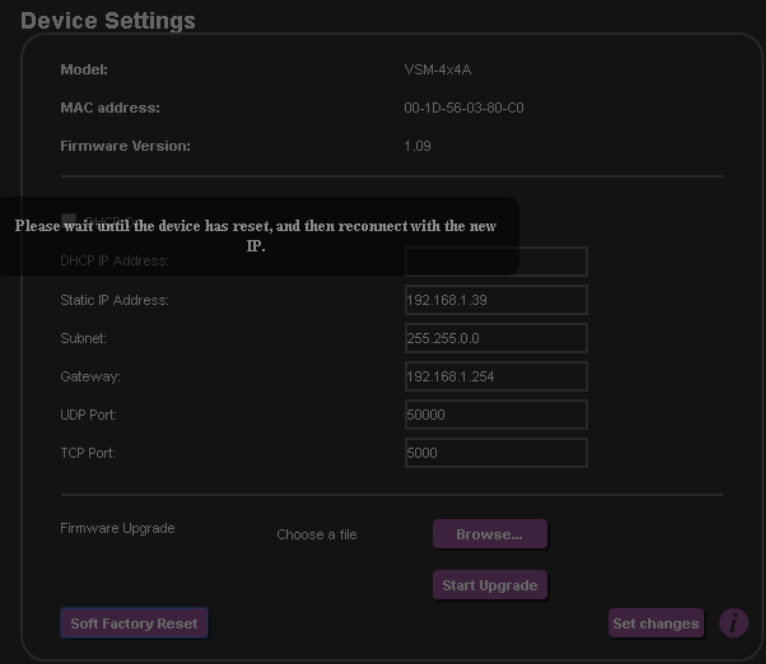

Figure 43: The Device Settings Page – Factory Reset Message

Click **OK** to proceed with factory reset:



The screenshot shows a web interface titled "Device Settings" for a VSM-4x4A device. At the top, it displays device information: Model (VSM-4x4A), MAC address (00-1D-58-03-80-C0), and Firmware Version (1.09). A prominent message states: "Please wait until the device has reset, and then reconnect with the new IP." Below this, there are input fields for network configuration: DHCP IP Address (empty), Static IP Address (192.168.1.39), Subnet (255.255.0.0), Gateway (192.168.1.254), UDP Port (50000), and TCP Port (5000). At the bottom, there are buttons for "Soft Factory Reset", "Firmware Upgrade" (with a "Browse..." button for file selection and a "Start Upgrade" button), and "Set changes" (with an information icon).

Figure 44: The Device Settings Page – Factory Reset



Following reset, type the new IP into your URL.

8.4 Output Settings Page

In the navigation pane, select **Output settings** to access the Output Settings page. Use Output Settings page to set the Mode, Resolution and Aspect Ratio and also enable/disable Auto-Sync Off.

[Figure 45](#) shows the Output Settings page for output A in the **Matrix** and **Video Wall** operation modes.

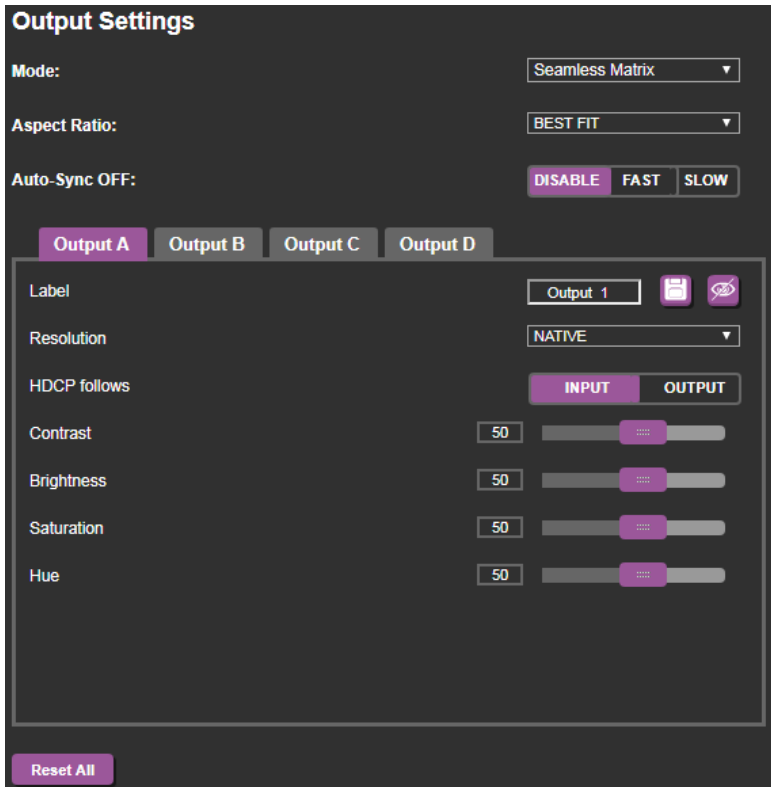

Figure 45: The Output Settings Page – Matrix and Video Wall Modes

Figure 46 shows the Output Settings page for output A in the **Dual-POP** operation mode.

Output Settings

Mode: Dual-POP

Aspect Ratio: BEST FIT

Auto-Sync OFF: DISABLE FAST SLOW

Output A left Output A right Output B left Output B right

Label: Output 1

Resolution: NATIVE

HDCP follows: INPUT OUTPUT

Contrast: 50

Brightness: 50

Saturation: 50

Hue: 50

Border: Only Selected

Border color: Green

Reset All

Figure 46: Output Settings Page – Dual-POP Mode

Figure 47 shows the Output Settings page for output A in the **Dual-PIP** operation mode.

Output Settings

Mode: Dual-PIP

Aspect Ratio: BEST FIT

Auto-Sync OFF: DISABLE FAST SLOW

Output AM Output AS Output BM Output BS

Label: Output 1

Resolution: NATIVE

HDCP follows: INPUT OUTPUT

Contrast: 50

Brightness: 50

Saturation: 50

Hue: 50

Border: Only Selected

Border color: Green

Reset All

Figure 47: Output Settings Page – Dual PIP Mode

[Figure 48](#) shows the Output Settings page for output A in the **Quad** operation mode.

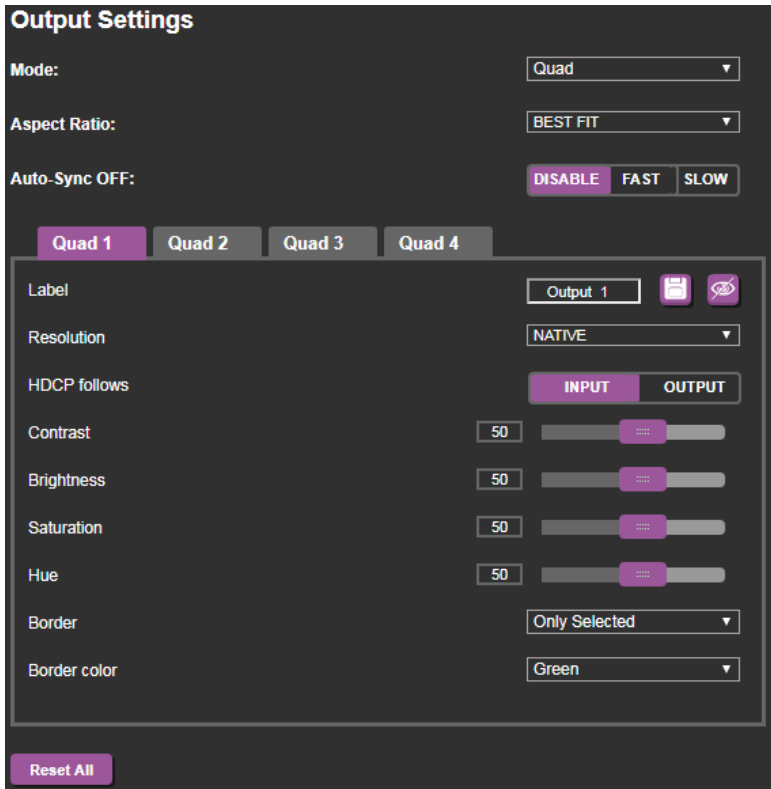



Figure 48: Output Settings Page – Quad Mode

You can perform the following operations:

- Open the **Mode** drop-down box to define the operation mode
- Open the Aspect Ratio drop-down box to set the aspect ratio
- Set **Auto-Sync OFF** to DISABLE, FAST or SLOW

For each output (labelled according to the current operation mode) you can:

- Edit the output **Label** – Type the new name and toggle  /  to view the label in the Web pages
- Set the output resolution via the resolution drop-down box
- Set **HDCP** to follow INPUT or OUTPUT
- Adjust the Contrast, Brightness, Saturation and Hue

Click the **Reset All** buttons to reset the output settings for all outputs.

8.5 Audio Settings Page

In the navigation pane, select **Audio settings** to access the Audio Settings page. Set the output audio levels (0 to 100) for each of the outputs:

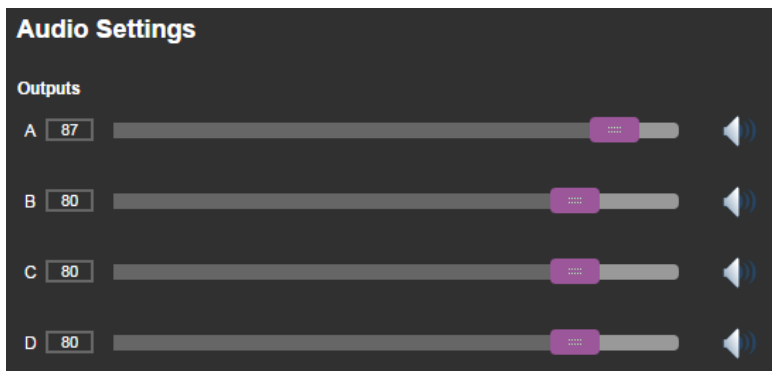

Figure 49: The Audio Settings Page

8.6 HDCP Settings Page

In the navigation pane, select **HDCP settings** to access the HDCP Settings page. Use HDCP settings page to view the HDCP data for the inputs and outputs and you change their settings to ON or OFF.

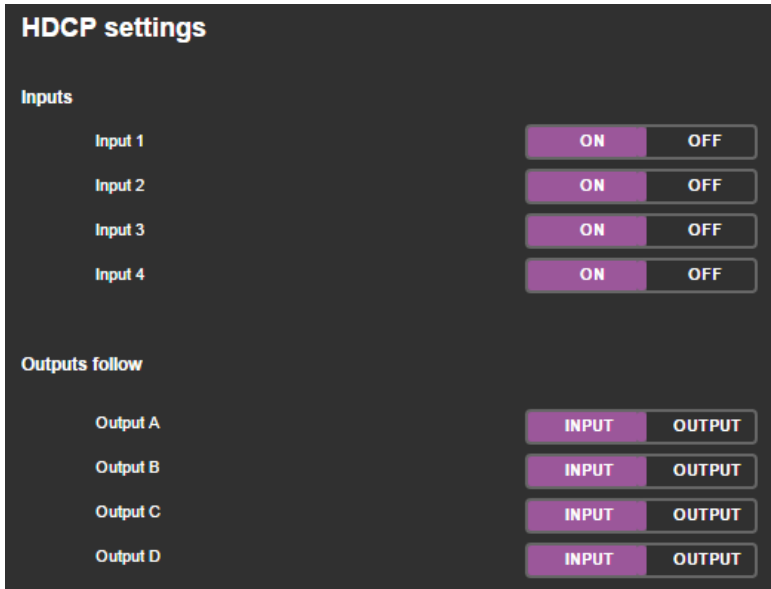

Figure 50: HDCP Settings Page

8.7 EDID Management Page

In the navigation pane, select **EDID management** to access the EDID Management page. Use the EDID management page to copy a selected resolution, the default resolution or a customized EDID file to one or more selected inputs.

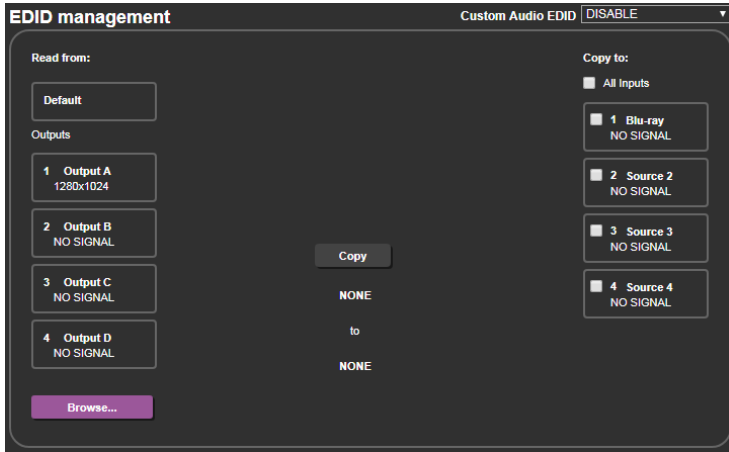

Figure 51: EDID Management Page

To read the EDID from an output (or Default):

1. Click an output (or Default).



Figure 52: EDID Management Page – selecting an Output

The EDID page displays the machine name, selected resolution, the audio channels and deep color support.

2. Select an input, several inputs or check the **All Inputs** box to select all the inputs.

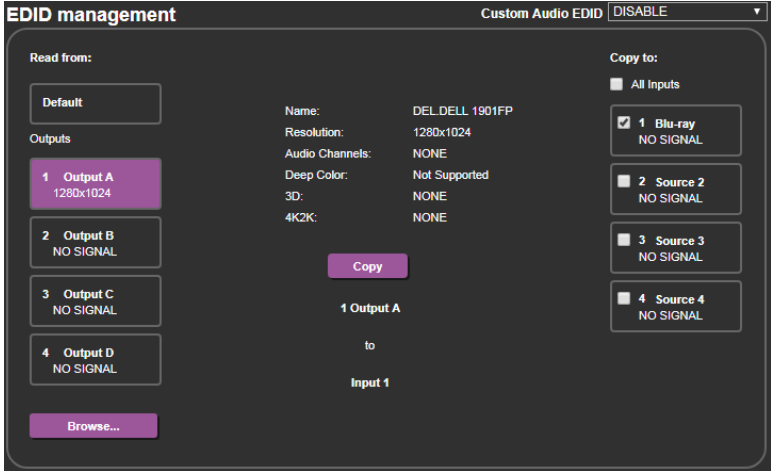

Figure 53: EDID Management Page – Copying the Native Timing

3. Click **Copy** and wait until EDID is copied.

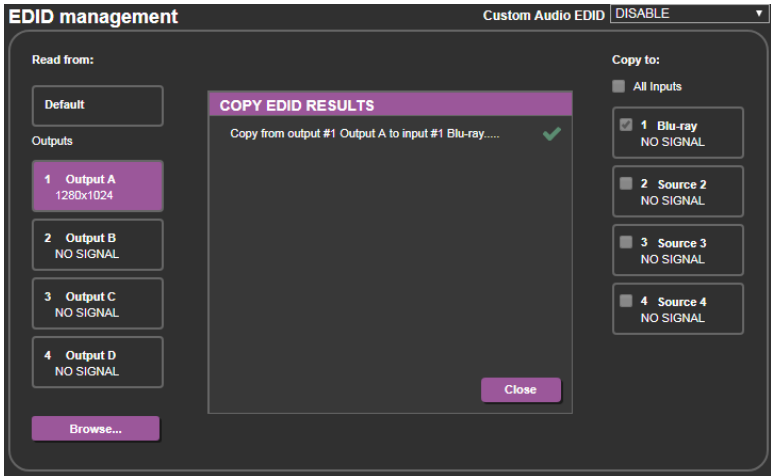

Figure 54: EDID Management Page – Copy EDID Results

To read the EDID from a file, Click **Browse...**, select the file and then click **Copy**.

8.8 About Page

The **VSM-4x4A** About page lets you view the Web page version and Kramer Electronics Ltd details.



Figure 55: The About Page

8.9 Saving and Uploading Configurations

The **VSM-4x4A** Web page lets you upload a saved configuration or save a configuration. To do so, click the Upload and buttons which are located at the lower part of the menu list, respectively.

When saving a configuration, the file automatically saves it to the Downloads.

When loading a configuration the following message appears:

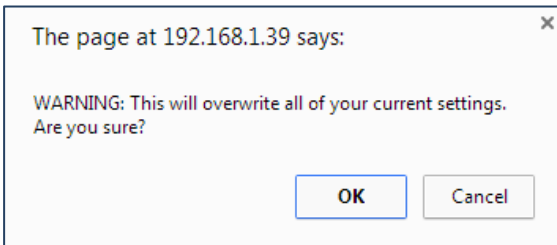

Figure 56: Loading a Configuration

9 Technical Specifications

Inputs	4 HDMI connectors (HDMI, HDCP version 1.1)
Outputs	4 HDMI connectors (HDMI, HDCP version 1.1) 4 balanced stereo audio on terminal block connectors 4 unbalanced audio on 3.5mm mini jacks
Output Resolutions	NATIVE, 480p, 576p, 720p50, 720p59, 720p60, 1080p24, 1080p50, 1080p60, 1024x768, 1280x800, 1280x1024, 1366x768, 1440x900, 1600x900, 1680x1050 or 1920x1200
Video Latency	Progressive input: 30ms (typical)
Controls	Front panel buttons, IR with customized remote control, RS-232, Ethernet with built-in Web pages, USB port for programming
Power Source	100-240V AC, 29VA max.
Regulatory Compliance	Safety: CE, UL, FCC Environmental: RoHS, WEEE
Operating Temperature	0° to +40°C (32° to 104°F)
Storage Temperature	-40° to +70°C (-40° to 158°F)
Humidity	10% to 90%, RHL non-condensing
Net Dimensions	19" x 7" x 1U (W, D, H) rack mountable
Shipping Dimensions	52.5cm x 33cm x 10.7cm (20.7" x 13" x 4.2") W, D, H
Net Weight	1.8kg (4lbs) approx.
Shipping Weight	2.7kg (6lbs) approx.
Included Accessories	Power cord, rack ears, IR remote control
Specifications are subject to change without notice at www.kramerav.com	

9.1 Default Communication Parameters

RS-232			
Baud Rate:	115,200	Stop Bits:	1
Data Bits:	8	Parity:	None
Ethernet			
To reset the IP settings to the factory reset values go to : Menu-> Factory-> RESET->Change the option to YES and press Enter			
IP Address:	192.168.1.39	Default TCP Port #:	5000
Subnet Mask:	255.255.255.0	Maximum TCP Ports:	4
Default Gateway:	192.168.1.254	Default UDP Port #:	50000
		Maximum UDP Ports:	4
Full Factory Reset			
OSD	Go to : Menu-> FACTORY DEFAULT -> Change the option to YES and press Enter		
P3000	Use "FACTORY" command		
Front Panel Buttons	Press the MENU Button while plugging the power to reset the machine		
RS-232/Ethernet Command Protocol			
Command Format:	ASCII		
Example (Route the video from the HDMI2 input to the HDMI A output port in the Matrix mode):	#ROUTE 0,1,2<cr>		

9.2 Supported Input Resolutions

Resolution	Resolution	Resolution
No signal	1152x864p75	1400x1050p60
640x480p59	1280x720p25 (720p25)	1440x900p60RB
640x480p72	1280x720p29 (720p29)	1440x900p60
640x480p75	1280x720p30 (720p30)	1440x900p75
640x480p85	1280x720p50 (720p50)	1600x900p60RB
720x400p70	1280x720p59 (720p59)	1600x1200p60
720x480i59 (480i59)	1280x720p60 (720p60)	1680x1050p60RB
720x480i60 (480i60)	1280x720p60CVT	1680x1050p60
720x480p59 (480p59)	1280x768p60RB	1920x1080p23 (1080p23)
720x480p60 (480p60)	1280x768p60	1920x1080p24 (1080p24)
720x576i50 (576i)	1280x768p75	1920x1080p25 (1080p25)
720x576p50 (576p)	1280x800p60RB	1920x1080p29 (1080p29)
800x600p56	1280x800p60	1920x1080p30 (1080p30)
800x600p60	1280x800p75	1920x1080i50 (1080i50)
800x600p72	1280x960p60	1920x1080p50 (1080p50)
800x600p75	1280x1024p60	1920x1080i59 (1080i59)
800x600p85	1280x1024p60CVT	1920x1080i60 (1080i60)
1024x768p60	1280x1024p75	1920x1080p59 (1080p59)
1024x768p70	1360x768p60	1920x1080p60 (1080p60)
1024x768p75	1366x768p60RB	1920x1200p60RB
1024x768p85	1366x768p60	
1152x864p70	1400x1050p60RB	

9.3 Supported Output Resolutions

Resolution	Resolution	Resolution
Native	1080p24	1366x768
480p	1080p50	1440x900
576p	1080p60	1600x900
720p50	1024x768	1680x1050
720p59	1280x800	1920x1200
720p60	1280x1024	

10 VSM-4x4A RS-232/Ethernet Communication Protocol

The **VSM-4x4A** 4x4 Seamless AV Matrix Switcher/Multi-Scaler can be operated using the Kramer Protocol 3000 serial commands. The command framing varies according to how you interface with the **VSM-4x4A**. In the following example, a basic video input switching command that routes a layer 1 video signal to HDBT out 1 from HDMI input 2 (`ROUTE 1, 1, 2`), is entered as follows:

- Terminal communication software, such as Hercules:

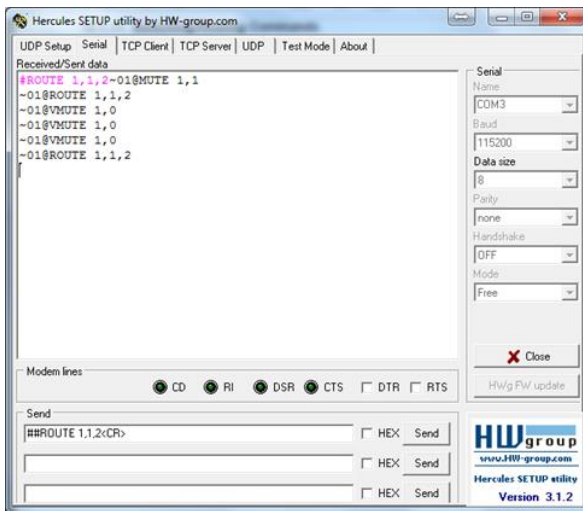

The framing of the command varies according to the terminal communication software. This command is used for demonstration purposes only and its syntax may vary per device.

- K-Touch Builder (Kramer software):

'Device Code (17)' PROPERTIES	
name	Device Code (17)
data	#ROUTE 1,1,2x0D

- K-Config (Kramer configuration software):

Command Syntax Display Command as Hex Decimal ASCII



All the examples provided in this section are based on using the Kramer K-Config software.

You can enter commands directly using terminal communication software (e.g., Hercules) by connecting a PC to the serial or Ethernet port on the **VSM-4x4A**. To enter `CR` press the Enter key (`LF` is also sent but is ignored by the command parser).

Commands sent from various non-Kramer controllers (e.g., Crestron) may require special coding for some characters (such as, `/x##`). For more information, refer to your controller's documentation.

For more information about:

- Using Protocol 3000 commands, see [Section 10.1](#)
- General syntax used for Protocol 3000 commands, see [Section 10.2](#)
- Protocol 3000 commands available for the **VSM-4x4A**, see [Section 10.3](#)

10.1 Understanding Protocol 3000

Protocol 3000 commands are structured according to the following:

- **Command** – A sequence of ASCII letters (A-Z, a-z and -). A command and its parameters must be separated by at least one space
- **Parameters** – A sequence of alphanumeric ASCII characters (0-9, A-Z, a-z and some special characters for specific commands). Parameters are separated by commas
- **Message string** – Every command entered as part of a message string begins with a message starting character and ends with a message closing character



A string can contain more than one command. Commands are separated by a pipe (|) character.

The maximum string length is 64 characters.

- **Message starting character:**
 - # – For host command/query
 - ~ – For device response
- **Device address** – K-NET Device ID followed by @ (optional, K-NET only)
- **Query sign** – ? follows some commands to define a query request
- **Message closing character:**
 - `CR` – Carriage return for host messages (ASCII 13)
 - `CR LF` – Carriage return for device messages (ASCII 13) and line-feed (ASCII 10)
- **Command chain separator character** – Multiple commands can be chained in the same string. Each command is delimited by a pipe character (|). When chaining commands, enter the message starting character and the message closing character only at the beginning and end of the string.



Spaces between parameters or command terms are ignored. Commands in the string do not execute until the closing character is entered. A separate response is sent for every command in the chain.

10.2 Kramer Protocol 3000 Syntax

The Kramer Protocol 3000 syntax uses the following delimiters:

- `CR` = Carriage return (ASCII 13 = 0x0D)
- `LF` = Line feed (ASCII 10 = 0x0A)
- `SP` = Space (ASCII 32 = 0x20)

Some commands have short name syntax in addition to long name syntax to enable faster typing. The response is always in long syntax.

The Protocol 3000 syntax is in the following format:

Host Message Format:

Start	Address (optional)	Body	Delimiter
#	<i>Device_id@</i>	Message	CR

Simple Command – Command string with only one command without addressing:

Start	Body	Delimiter
#	Command SP <i>Parameter_1,Parameter_2,...</i>	CR

Command String – Formal syntax with command concatenation and addressing:

Start	Address	Body	Delimiter
#	<i>Device_id@</i>	Command_1 <i>Parameter1_1,Parameter1_2,...</i> Command_2 <i>Parameter2_1,Parameter2_2,...</i> Command_3 <i>Parameter3_1,Parameter3_2,...</i> ...	CR

- **Device Message Format:**

Start	Address (optional)	Body	Delimiter
~	<i>Device_id@</i>	Message	CR LF

- **Device Long Response** – Echoing command:

Start	Address (optional)	Body	Delimiter
~	<i>Device_id@</i>	Command SP [<i>Param1,Param2 ...</i>] result	CR LF

10.3 Protocol 3000 Commands

This section includes the following commands:

- Mandatory System Commands (see [Section 10.3.1](#))
- System Commands (see [Section 10.3.2](#))
- Switching/Routing Commands (see [Section 10.3.3](#))
- Video Commands (see [Section 10.3.4](#))
- Audio Commands (see [Section 10.3.5](#))
- Communication Commands (see [Section 10.3.6](#))
- Multiviewer/Scaler Commands (see [Section 10.3.7](#))
- Custom Commands (see [Section 10.3.8](#))
- Miscellaneous Commands (see [Section 10.3.9](#))

10.3.1 Mandatory System Commands

Command	Description
#	Protocol handshaking (system mandatory)
BUILD-DATE	Get device build date (system mandatory)
FACTORY	Reset to factory default configuration
HELP	Get command list (system mandatory)
MODEL	Get device model (system mandatory)
PROT-VER	Get device protocol version (system mandatory)
RESET	Reset device (system mandatory)
SN	Get device serial number (system mandatory)
VERSION	Get device firmware version (system mandatory)

10.3.1.1

Functions		Permission	Transparency
Set:	#	End User	Public
Get:	-	-	-
Description		Syntax	
Set:	Protocol handshaking	# CR	
Get:	-	-	
Response			
~nn@SE OK CR LF			
Notes			
Validates the Protocol 3000 connection and gets the machine number Step-in master products use this command to identify the availability of a device			
K-Config Example			
"#", 0x0D			

10.3.1.2 BUILD-DATE

Functions		Permission	Transparency
Set:	BUILD-DATE	End User	-
Get:	-	-	-
Description		Syntax	
Set:			
Get:	get device build date	#BUILD-DATE? CR	
Response			
~nn@BUILD-DATESEdateSEtimeCR LF			
Parameters			
date – Format: YYYY/MM/DD where YYYY = Year, MM = Month, DD = Day time – Format: hh:mm:ss where hh = hours, mm = minutes, ss = seconds			
K-Config Example			
Read the device build date: "#BUILD-DATE?", 0x0D			

10.3.1.3 FACTORY

Functions		Permission	Transparency
Set:	FACTORY	End User	Public
Get:	-	-	-
Description		Syntax	
Set:	Reset device to factory defaults configuration	# FACTORY CR	
Get:	-	-	
Response			
~ nn @ FACTORY SP OK CR LF			
Notes			
This command deletes all user data from the device. The deletion can take some time. Your device may require powering off and powering on for the changes to take effect.			
K-Config Example			
Reset the device to its factory default configuration: "#FACTORY", 0x0D			

10.3.1.4 HELP

Functions		Permission	Transparency
Set:	-	-	-
Get:	HELP	End User	Public
Description		Syntax	
Set:	-	-	
Get:	Get command list or help for specific command	1. # HELP CR 2. # HELP SP COMMAND_NAME CR	
Response			
1. Multi-line: ~ nn @Device available protocol 3000 commands: CR LF command, SP command... CR LF 2. Multi-line: ~ nn @ HELP SP command: CR LF description CR LF USAGE:usage CR LF			
Parameters			
COMMAND_NAME – name of a specific command			
Notes			
To get help for a specific command use: HELP SP COMMAND_NAME CR LF			
K-Config Example			
"#HELP", 0x0D			

10.3.1.5 MODEL

Functions		Permission	Transparency
Set:	-	-	-
Get:	MODEL?	End User	Public
Description		Syntax	
Set:	-		
Get:	Get device model	# MODEL? <code>CR</code>	
Response			
~ <code>nn</code> @ MODEL <code>SP</code> model_name <code>CR LF</code>			
Parameters			
model_name – String of up to 19 printable ASCII chars			
Notes			
This command identifies equipment connected to Step-in master products and notifies of identity changes to the connected equipment. The Matrix saves this data in memory to answer REMOTE-INFO requests			
K-Config Example			
Get device model: `"#MODEL?"`, 0x0D			

10.3.1.6 PROTV-ER

Functions		Permission	Transparency
Set:	-	-	-
Get:	PROT-VER?	End User	Public
Description		Syntax	
Set:	-		
Get:	Get protocol version	# PROT-VER? <code>CR</code>	
Response			
~ <code>nn</code> @ PROT-VER <code>SP</code> 3000:version <code>CR LF</code>			
Parameters			
Version – Format: XX.XX where X is a decimal digit			
K-Config Example			
Get the protocol version: `"#PROT-VER?"`, 0x0D			

10.3.1.7 RESET

Functions		Permission	Transparency
Set:	RESET	Administrator	Public
Get:	-	-	-
Description		Syntax	
Set:	Reset device	#RESET <input type="checkbox"/>	
Get:	-	-	
Response			
~ <input type="checkbox"/> @RESET <input type="checkbox"/> Ok <input type="checkbox"/> CR LF			
Notes			
To avoid locking the port due to a USB bug in Windows, disconnect USB connections immediately after running this command. If the port was locked, disconnect and reconnect the cable to reopen the port.			
K-Config Example			
Reset the device: "#RESET", 0x0D			

10.3.1.8 SN

Functions		Permission	Transparency
Set:	-	-	-
Get:	SN?	End User	Public
Description		Syntax	
Set:	-	-	
Get:	Get device serial number	#SN? <input type="checkbox"/>	
Response			
~ <input type="checkbox"/> @SN <input type="checkbox"/> serial_number <input type="checkbox"/> CR LF			
Parameters			
serial_number – 14 decimal digits, factory assigned			
K-Config Example			
Get device serial number: "#SN?", 0x0D			

10.3.1.9 VERSION

Functions		Permission	Transparency
Set:	-	-	-
Get:	VERSION?	End User	Public
Description		Syntax	
Set:	-	-	
Get:	Get version number	#VERSION?CR	
Response			
~nn@VERSIONSEffirmware_versionCR LF			
Parameters			
firmware_version – Format: XX.XX.XXXX where the digits group are: major.minor.build version			
K-Config Example			
Get the firmware version number: "#VERSION?",0x0D			

10.3.2 System Commands

Command	Description
CPEDID	Copy EDID data from the output to the input EEPROM
DISPLAY	Get output HPD status
HDCP-MOD	Set/get HDCP mode
HDCP-STAT	Get HDCP signal status
INFO-IO	Get IN/OUT count (port)
INFO-PRST	Get maximum preset count
LOCK-FP	Get front panel lock state
PRST-LST	Get saved preset list
PRST-RCL	Recall saved preset
PRST-STO	Store current connections
PRST-VID	Get video connections from saved preset
SIGNAL	Get input signal lock status

10.3.2.1 CPEDID

Functions		Permission	Transparency
Set:	CPEDID	End User	Public
Get:	-	-	-
Description		Syntax	
Set:	Copy EDID data from the output to the input EEPROM	#CPEDID SP src_type,src_id,dst_type,dest_bitmap CR	
Get:	-	-	
Response			
~nn@CPEDID SP src_type,src_id,dst_type,dest_bitmap CR LF			
Parameters			
src_type – EDID source type: 1 (Output) src_id – 1 (OUT A), 2 (OUT B), 3 (OUT C), 4 (OUT D), 5 (Default), 6 (Upload file) dst_type – 0 (input) dest_bitmap – bit0 (IN 1), bit1 (IN 2), bit2 (IN 3), bit3 (IN 4) bitmap representing destination IDs. Format: XXXX...X, where X is hex digit. The binary form of every hex digit represents corresponding destinations. Setting '1' indicates that EDID data is copied to this destination. Setting '0' indicates that EDID data is not copied			
Response Triggers			
Response is sent to the com port from which the Set was received (before execution)			
Notes			
Destination bitmap size depends on device properties (for 4 inputs it is a 4-bit word) Example: bitmap 0x09 means inputs 1 and 4 are loaded with the new EDID			
K-Config Example			
Copy the EDID data from the Output 1 (EDID source) to the Input: <pre>"#CPEDID 1,1,0,0x1",0x0D</pre>			
Copy the EDID data from the default EDID source to the Input: <pre>"#CPEDID 2,0,0,0x1",0x0D</pre>			

10.3.2.2 DISPLAY

Functions		Permission	Transparency
Set:	-	-	-
Get	DISPLAY?	End User	System
Description		Syntax	
Set:	-	-	
Get:	Get output HPD status	# DISPLAY? <u>S</u> <u>P</u> out_id <u>C</u> <u>R</u>	
Response			
~ <u>nn</u> @ DISPLAY <u>S</u> <u>P</u> out_id,status <u>C</u> <u>R</u> <u>L</u> <u>F</u>			
Parameters			
Out_id – Output number: 1 (OUT A), 2 (OUT B), 3 (OUT C), 4 (OUT D), * (ALL)			
status – Output number: 0 (Sink is not valid), 1 (Sink is valid), 2 (Sink and good EDID are valid)			
Response triggers			
<ul style="list-style-type: none"> • After execution, response is sent to the com port from which the Get was received • Response is sent after every change in output HPD status ON to OFF • Response is sent after every change in output HPD status OFF to ON and ALL parameters (new EDID, etc.) are stable and valid 			
K-Config Example			
Get the output HPD status: "#DISPLAY?",0x0D			

10.3.2.3 HDCP-MOD

Functions		Permission	Transparency
Set:	HDCP-MOD	Administrator	Public
Get:	HDCP-MOD?	End User	System
Description		Syntax	
Set:	Set HDCP mode	# HDCP-MOD [SP stage,stage_id,mode] CR	
Get:	Get HDCP mode	# HDCP-MOD? [SP stage,stage_id] CR	
Response			
Set / Get: ~[nn]@ HDCP-MOD [SP stage,stage_id,mode] CR LF			
Parameters			
stage – Input or Output: 0 (Input), 1 (Output)			
stage_id – For Input: 1 (IN 1), 2 (IN 2), 3 (IN 3), 4 (IN 4), * (ALL); for output: 1 (OUT A), 2 (OUT B), 3 (OUT C), 4 (OUT D), * (ALL)			
mode – status for Input: 0 (Off), 1 (On) and status for Output: 2 (Follow In), 3 (Follow Out)			
Response triggers			
<ul style="list-style-type: none"> • Response is sent to the com port from which the Set (before execution) / Get command was received • Response is sent to all com ports after execution if HDCP-MOD was set any other external control device (button press, device menu and similar) or genlock status changed 			
Notes			
Set HDCP working mode on device input : HDCP supported – HDCP_ON [default] HDCP not supported – HDCP_OFF HDCP support changes following detected sink – MIRROR OUTPUT			
K-Config Example			
Set HDCP mode on HDMI 1 output to Follow out: `#HDCP-MOD 1,0,3",0x0D			

10.3.2.4 HDCP-STAT

Functions		Permission	Transparency
Set:	-	-	-
Get:	HDCP-STAT?	End User	Public
Description		Syntax	
Set:	None	-	
Get:	Get HDCP signal status	# HDCP-STAT? [SP]stage,stage_id[CR]	
Response			
~[nn]@ HDCP-STAT [SP]stage,stage_id,mode[CR LF]			
Parameters			
stage – 0 (input), 1 (output)			
stage_id – for input: 1 (IN 1), 2 (IN 2), 3 (IN 3), 4 (IN 4), * (All); for output: 1 (OUT A), 2 (OUT B), 3 (OUT C), 4 (OUT D), * (All)			
mode – signal encryption On/Off status: 0 (Off), 1 (On)			
Response triggers			
Response is sent to the com port from which the Set (before execution) / Get command was received Response is sent to all com ports after execution if HDCP-STAT was set by any other external control device (button press, device menu and similar) or HDCP mode changed.			
Notes			
On output – sink status; On input – signal status. On Video outputs the HDCP-STAT response will tell us if the SINK supports HDCP (and not if the actual signal is HDCP protected) and just in case a signal is sent to the output. In case no Signal is routed to this specific output the status could be inaccurate or missing at all.			
K-Config Example			
Get the output HDCP-STATUS of IN 1: `#HDCP-STAT? 0,1",0x0D`			

10.3.2.5 INFO-IO

Functions		Permission	Transparency
Set:			
Get:	INFO-IO?	End User	Public
Description		Syntax	
Set:			
Get:	Get IN/OUT count	# INFO-IO? [CR]	
Response			
~[nn]@ INFO-IO? [SP]IN[SP]inputs_count,OUT[SP]outputs_count[CR LF]			
Parameters			
inputs_count – 4			
outputs_count – 4			
K-Config Example			
Get the number of ports: `#INFO-IO?",0x0D`			

10.3.2.6 INFO-PRST

Functions		Permission	Transparency
Set:			
Get:	INFO-PRST?	End User	Public
Description		Syntax	
Set:			
Get:	Get maximum preset count	#INFO-PRST? CR	
Response			
~nn@INFO-PRST?SEVIDSEpreset_video_count,AUDSEpreset_audio_count CR LF			
Parameters			
video_count - 4 audio_count - 0 (does not support audio preset)			
K-Config Example			
Get the maximum preset count: "#INFO-PRST?",0x0D			

10.3.2.7 LOCK-FP

Functions		Permission	Transparency
Set:	LOCK-FP	End User	-
Get:	LOCK-FP?	End User	System
Description		Syntax	
Set:	Lock front panel	#LOCK-FPSElock_mode CR	
Get:	Get front panel lock state	#LOCK-FP? CR	
Response			
~nn@LOCK-FPSElock_modeSEOK CR LF			
Parameters			
lock_mode - 0 (Off - unlock) 1 (On - lock)			
K-Config Example			
Lock front panel: "#LOCK-FP 1",0x0D			

10.3.2.8 PRST-LST

Functions		Permission	Transparency
Set:			
Get:	PRST-LST?	End User	Public
Description		Syntax	
Set:	-		
Get:	Get saved preset list	# PRST-LST? <input type="checkbox"/>	
Response			
~nn@ PRST-LST <input type="checkbox"/> preset,preset,.. <input type="checkbox"/> <input type="checkbox"/>			
Parameters			
preset - 1,2,3,4			
Notes			
In most units, video and audio presets with the same number are stored and recalled together by commands #PRST-STO and #PRST-RCL			
K-Config Example			
Get saved preset list: "#PRST-LST?",0x0D			

10.3.2.9 PRST-RCL

Functions		Permission	Transparency
Set:	PRST-RCL	End User	Public
Get:			
Description		Syntax	
Set:	Recall saved preset	# PRST-RCL <input type="checkbox"/> preset <input type="checkbox"/>	
Get:			
Response			
~nn@ PRST-RCL <input type="checkbox"/> preset <input type="checkbox"/> <input type="checkbox"/>			
Parameters			
preset - 1,2,3 or 4			
Notes			
In most units, video and audio presets with the same number are stored and recalled together by commands #PRST-STO and #PRST-RCL			
K-Config Example			
Recall preset 2: "#PRST-RCL 2",0x0D			

10.3.2.10 PRST-STO

Functions		Permission	Transparency
Set:	PRST-STO	End User	Public
Get:			
Description		Syntax	
Set:	Store current connections	#PRST-STO SP preset CR	
Get:			
Response			
~nn@PRST-STO SP preset CR LF			
Parameters			
preset - 1,2,3 or 4			
Notes			
In most units, video and audio presets with the same number are stored and recalled together by commands #PRST-STO and #PRST-RCL			
K-Config Example			
Store preset 2: "#PRST-STO 2",0x0D			

10.3.2.11 PRST-VID

Functions		Permission	Transparency
Set:			
Get:	PRST-VID?	End User	Public
Description		Syntax	
Set:			
Get:	Get video connections from saved preset	#PRST-VID? SP preset, out CR #PRST-VID? SP preset, * CR	
Response			
~nn@PRST-VID SP preset, in>out CR LF ~nn@PRST-VID SP preset, in>1, in>2, in>3... CR LF			
Parameters			
preset - 1,2,3 or 4 in - 1 (IN 1), 2 (IN 2), 3 (IN 3), 4 (IN 4), 5 (Off) out - 1 (OUT A), 2 (OUT B), 3 (OUT C), 4 (OUT D), * (All)			
Notes			
In most units, video and audio presets with the same number are stored and recalled together by commands #PRST-STO and #PRST-RCL			
K-Config Example			
Get video connections of output 3 from preset 4: "#PRST-LST? 4, 3",0x0D			

10.3.2.12 SIGNAL

Functions		Permission	Transparency
Set:	-	-	-
Get:	SIGNAL?	End User	Public
Description		Syntax	
Set:	-	-	
Get:	Get input signal lock status	# SIGNAL? <u>SP</u> inp_id <u>CR</u>	
Response			
~ <u>nn</u> @ SIGNAL <u>SP</u> inp_id,status <u>CR LF</u>			
Parameters			
inp_id – 1 (IN 1), 2 (IN 2), 3 (IN 3), 4 (IN 4), * (All) status – 0 (Signal is not valid), 1 (Signal is valid)			
Notes			
After execution, a response is sent to the com port from which the Get was received A response is sent after every change in input signal status from On to Off or from Off to On			
K-Config Example			
Get the signal lock status of IN 1: "#SIGNAL? 1",0x0D			

10.3.3 Switching/Routing Commands

Command	Description
ROUTE	Set/get layer routing

10.3.3.1 ROUTE

Functions		Permission	Transparency
Set:	ROUTE	End User	-
Get:	ROUTE?	End User	Switching
Description		Syntax	
Set:	Set layer routing	# ROUTE <u>SP</u> layer,dest,src <u>CR</u>	
Get:	Get layer routing	# ROUTE? <u>SP</u> layer,dest <u>CR</u>	
Response			
~ <u>nn</u> @ ROUTE <u>SP</u> layer,dest,src <u>CR LF</u>			
Parameters			
layer – Layer number: 1 (Video), 2 (Audio for Dual and Quad modes only) dest – 1 (OUT A), 2 (OUT B), 3 (OUT C), 4 (OUT D), * (All) src – 1 (IN 1), 2 (IN 2), 3 (IN 3), 4 (IN 4), 5 (Off - not for audio) Audio for Dual mode: dest – 1 (OUT A), 2 (OUT B), 3 (OUT C), 4 (OUT D) src – for dual A: 1 (IN 1), 2 (IN 2); for dual B: 3 (IN 3), 4 (IN 4)			
Notes			
This command replaces all other routing commands.			
K-Config Example			
Select the IN 2 video input to route output 1: "#ROUTE 1,1,2",0x0D			

10.3.4 Video Commands

Command	Description
VID-RES	Set/get video resolution
VMUTE	Set/get video on output mute

10.3.4.1 VID-RES

Functions	Permission	Transparency
Set:	VID-RES	End User
Get	VID-RES?	End User
Get	VID-RES?	Video
Description	Syntax	
Set:	Set video resolution	#VID-RES ^{SE} stage,stage_id,is_native,resolution ^{CR}
Get:	Get video resolution	#VID-RES? ^{SE} stage,stage_id,is_native ^{CR}
Response		
	~nn@VID-RES ^{SE} stage,stage_id,is_native,resolution ^{CR LF}	
Parameters		
	stage – 0 (Input), 1 (Output); under SET, stage 1 only	
	stage_id – For Input: 1 (IN 1), 2 (IN 2), 3 (IN 3), 4 (IN 4); for output: 1 (OUT A), 2 (OUT B), 3 (OUT C), 4 (OUT D), * (ALL);	
	NOTE: for the Seamless Matrix, Video Wall and Quad modes, the resolution on all the outputs is the same; for the Independent Matrix mode, each output can have a different resolution; for the Dual mode, Dual A and Dual B can have different resolutions	
	is_native – 0 (Off), 1 (On)	
	NOTE: Under SET is_native is ignored	
	resolution – 0-63 (see Section 10.3.10)	
Response triggers		
	<ul style="list-style-type: none"> After execution, response is sent to the com port from which the Set /Get was received After execution, response is sent to all com ports if VID-RES was set by any other external control device (button press, device menu and similar) 	
Notes		
	<ol style="list-style-type: none"> The “Set” command is only applicable when stage = 1 (Output) The “Set” command with is_native = 1 (On), sets the native resolution on the selected output (resolution index sent = 0). The device sends as an answer the actual VIC ID of native resolution. The “Get” command with is_native = 1 (On) returns the native resolution VIC; when is_native = 1 (Off), it returns the current resolution 	
K-Config Example		
	Set video resolution on output to 1400x1050 @60Hz: `#VID-RES 1,1,0,44”,0x0D`	

10.3.4.2 VMUTE

Functions		Permission	Transparency
Set:	VMUTE	End User	Public
Get:	VMUTE?	End User	Video
Description		Syntax	
Set:	Set enable/disable video on output	# VMUTE [SE]output_id,flag[CR]	
Get:	Get video on output status	# VMUTE? [SE]output_id[SE][CR]	
Response			
Set / Get: ~[nn]@ VMUTE [SE]output_id,flag[CR][LF]			
Parameters			
Output_id – 1 (OUT A), 2 (OUT B), 3 (OUT C), 4 (OUT D), * (All) flag –video mute status: 0 (Disable video, TMDS and 5V out are off), 1 (Enable video), 2 (blank screen)			
K-Config Example			
Set Mute video on output A to off: `#VMUTE 1,0",0x0D			

10.3.5 Audio Commands

Command	Description
AUD-LVL	Set/get input/output volume
MUTE	Mute the output

10.3.5.1 AUD-LVL

Functions		Permission	Transparency
Set:	AUD-LVL	End User	-
Get:	AUD-LVL?	End User	Audio
Description		Syntax	
Set:	Set audio level in specific amplifier stage	# AUD-LVL [SE]stage,channel,volume[CR]	
Get:	Get audio level in specific amplifier stage	# AUD-LVL? [SE]stage,channel[CR]	
Response			
~[nn]@ AUD-LVL [SE]stage,channel[CR][LF]			
Parameters			
stage – 2 (Analog output) channel – 1 (OUT A), 2 (OUT B), 3 (OUT C), 4 (OUT D), * (All) volume – 0-100 (audio level) minus sign precedes negative values. ++ (+1, increase current value by one step) -- (-1, decrease current value by one step)			
K-Config Example			
Set OUT B audio level to 75: `#AUD-LVL 2,2,75",0x0D			

10.3.5.2 MUTE

Functions		Permission	Transparency
Set:	MUTE	End User	Public
Get:	MUTE?	End User	Audio
Description		Syntax	
Set:	Mute the selected output	#MUTE <code>[SP]</code> channel,mute_mode <code>[CR]</code>	
Get:	Mute the selected output	#MUTE? <code>[SP]</code> channel <code>[CR]</code>	
Response			
Set / Get: ~ <code>[nn]</code> @MUTE <code>[SP]</code> channel,mute_mode <code>[CR]</code> <code>[LF]</code>			
Parameters			
channel – * (All)			
mute_mode – mute the output: 0 (Off, unmute), 1 (On, mute)			
Response triggers			
Response is sent to the com port from which the Set (before execution) / Get command was received After execution, response is sent to all com ports if CMD-NAME was set any other external control device (button press, device menu and similar) or genlock status was changed			
Notes			
Mutes the audio output			
K-Config Example			
Mute the outputs: "#MUTE *,1",0x0D			

10.3.6 Communication Commands

Command	Description
NET-MAC	Get MAC address
NET-IP	Set/get IP address
NET-GATE	Set/get gateway IP
NET-MASK	Set/get subnet mask
NET-DHCP	Set/get DHCP mode
ETH-PORT	Set/get Ethernet port protocol

10.3.6.1 NET-MAC

Functions	Permission	Transparency
Set:	-	-
Get:	NET-MAC?	End User Communication
Description	Syntax	
Set:		
Get:	Get MAC address	#NET-MAC? [CR]
Response		
~nn@NET-MAC [SP] mac_address [CR LF]		
Parameters		
mac_address – Unique MAC address. Format: XX-XX-XX-XX-XX-XX where X is hex digit.		
K-Config Example		
Get the MAC address: "#NET-MAC? XX-XX-XX-XX-XX-XX", 0x0D		

10.3.6.2 NET IP

Functions	Permission	Transparency
Set:	NET-IP	Administrator -
Get:	NET-IP?	End User Communication
Description	Syntax	
Set:	Set device IP address	#NET-IP [SP] P1 [CR]
Get:	Get device IP address	#NET-IP? [CR]
Response		
Set: ~nn@NET-IP [SP] ip_address [SP]OK[CR LF]		
Get: ~nn@NET-IP [SP] ip_address [CR LF]		
Parameters		
P1 – IP address, in the following format: xxx.xxx.xxx.xxx		
Notes		
For proper settings consult your network administrator.		
K-Config Example		
Set the IP address to 192.168.1.39: "#NET-IP 192.168.001.039", 0x0D		

10.3.6.3 NET-GATE

Functions		Permission	Transparency
Set:	NET-GATE	Administrator	-
Get:	NET-GATE?	End User	Communication
Description		Syntax	
Set:	Set Gateway IP	#NET-GATE ^{SP} P1 ^{CR}	
Get:	Get Gateway IP	#NET-GATE? ^{CR}	
Response			
Set:	~nn@NET-GATE ^{SP} P1 ^{SP} OR ^{CR LF}		
Get:	~nn@NET-GATE ^{SP} ip_address ^{CR LF}		
Parameters			
P1 – gateway IP address, in the following format:			
Notes			
A network gateway connects the device via another network and maybe over the Internet. Be careful of security problems. For proper settings consult your network administrator			
K-Config Example			
Set the gateway IP address to 192.168.0.1: "#NET-GATE 192.168.000.001",0x0D			

10.3.6.4 NET-MASK

Functions		Permission	Transparency
Set:	NET-MASK	Administrator	-
Get:	NET-MASK?	End User	Communication
Description		Syntax	
Set:	Set device subnet mask	#NET-MASK ^{SP} net_mask ^{CR}	
Get:	Get device subnet mask	#NET-MASK? ^{CR}	
Response			
Set:	~nr@NET-MASK ^{SP} P1 ^{SP} OR ^{CR LF}		
Get:	~nr@NET-MASK ^{SP} net_mask ^{CR LF}		
Parameters			
P1 – net-mask format: xxx.xxx.xxx.xxx			
Response triggers			
The subnet mask limits the Ethernet connection within the local network. For proper settings consult your network administrator.			
K-Config Example			
Set the subnet mask to 255.255.0.0: "#NET-MASK 255.255.000.000",0x0D			

10.3.6.5 NET-DHCP

Functions		Permission	Transparency
Set:	NET-DHCP	Administrator	-
Get:	NET-DHCP?	End User	Communication
Description		Syntax	
Set:	Set DHCP mode	# NET-DHCP <input type="checkbox"/> P1 <input type="checkbox"/> CR	
Get:	Get DHCP mode	# NET-DHCP? <input type="checkbox"/> CR	
Response			
Set:	~nn@ NET-DHCP <input type="checkbox"/> P1 <input type="checkbox"/> OK CR LF		
Get:	~nn@ NET-DHCP <input type="checkbox"/> mode CR LF		
Parameters			
P1 – use static IP: 0 (Static IP) or use DHCP: 1 (DHCP). If DHCP is unavailable, use the IP address set by the factory or the NET-IP command			
Notes			
Connecting Ethernet to devices with DHCP may take more time in some networks. To connect with a randomly assigned IP by DHCP, specify the device DNS name (if available) using the command "NAME". You can also get an assigned IP by direct connection to USB or RS-232 protocol port if available. For proper settings consult your network administrator.			
K-Config Example			
Set the DHCP mode to static: "#NET-DHCP 0", 0x0D			

10.3.6.6 ETH-PORT

Functions		Permission	Transparency
Set:	ETH-PORT	Administrator	Public
Get:	ETH-PORT?	End User	Public
Description		Syntax	
Set:	Set Ethernet port protocol	# ETH-PORT <input type="checkbox"/> porttype, ethport <input type="checkbox"/> CR	
Get:	Get Ethernet port protocol	# ETH-PORT? <input type="checkbox"/> porttype <input type="checkbox"/> CR	
Response			
Set:	~nn@ ETH-PORT <input type="checkbox"/> porttype, ethport <input type="checkbox"/> CR LF		
Parameters			
porttype – 0 (TCP) ethport – 1 to 65535			
K-Config Example			
Set TCP to 2: "#ETH-PORT 0, 2", 0x0D			

10.3.7 Multiviewer/Scaler Commands

Command	Description
BRIGHTNESS	Set/get window brightness
CONTRAST	Set/get window contrast
IMAGE-PROP	Set/get the image size
SCLR-AS	Set/get the auto sync off timer
SHOW-OSD	Set the OSD of the selected channel
W-BRD	Set/get window border
W-HUE	Set/get picture hue
W-SATURATION	Set/get picture saturation
VW-POS	Set/get 1x4 video wall position-H value

10.3.7.1 BRIGHTNESS

Functions		Permission	Transparency
Set:	BRIGHTNESS	End User	Public
Get:	BRIGHTNESS?	End User	Public
Description		Syntax	
Set:	Set window brightness	# BRIGHTNESS [SP]win_num,value[CR]	
Get:	Get window brightness	# BRIGHTNESS? [SP]win_num[CR]	
Response			
Set / Get: ~nn@ CONTRAST [SP]win_num,value[CR LF]			
Parameters			
win_num - 1 (OUT A), 2 (OUT B), 3 (OUT C), 4 (OUT D), * (All) value - 0~100			
K-Config Example			
Set brightness of OUT A to 56: "#BRIGHTNESS 1,56",0x0D			

10.3.7.2 CONTRAST

Functions		Permission	Transparency
Set:	CONTRAST	End User	Public
Get:	CONTRAST?	End User	Public
Description		Syntax	
Set:	Set window contrast	# CONTRAST [SP]win_num,value[CR]	
Get:	Get window contrast	# CONTRAST? [SP]win_num[CR]	
Response			
Set / Get: ~nn@ CONTRAST [SP]win_num,value[CR LF]			
Parameters			
win_num - 1 (OUT A), 2 (OUT B), 3 (OUT C), 4 (OUT D), * (All) value - 0~100			
K-Config Example			
Set contrast of OUT A to 65: "#CONTRAST 1,65",0x0D			

10.3.7.3 IMAGE PROP

Functions		Permission	Transparency
Set:	IMAGE-PROP	End User	Public
Get:	IMAGE-PROP?	End User	Video
Description		Syntax	
Set:	Set the image size	# IMAGE-PROP [SP P1, P2] CR	
Get:	Get the image size	# IMAGE-PROP? [SP P1] CR	
Response			
Set / Get: ~[nr]@ IMAGE-PROP [SP P1, P2] CR LF			
Parameters			
P1 – * (All) P2 – Aspect ratio: 1 (Full), 2 (Best Fit), 3 (PanScan, 4:3), 4 (Letter Box, 16:9)			
Response triggers			
Response is sent to the com port from which the Set (before execution) / Get command was received After execution, response is sent to all com ports if CMD-NAME was set any other external control device (button press, device menu and similar) or genlock status was changed			
Notes			
All 4 scalers have the same aspect ratio			
K-Config Example			
Set the image size to PanScan: `#IMAGE-PROP *, 3", 0x0D			

10.3.7.4 SCALER-AS

Functions		Permission	Transparency
Set:	SCLR-AS	End User	Public
Get:	SCLR-AS?	End User	Audio
Description		Syntax	
Set:	Set the auto sync off timer	# SCLR-AS [SP P1, P2] CR	
Get:	Get the auto sync off timer definition	# SCLR-AS? [SP P1] CR	
Response			
Set / Get: ~[nr]@ SCLR-AS [SP P1, P2] CR LF			
Parameters			
P1 – * (All) P2 – For setting the auto sync timer: 0 (Disable), 1 (Fast, 10sec), 2 (Slow, 2min)			
Response triggers			
The auto-sync feature determines whether the outputs are turned off when no video is detected on the selected input			
Notes			
All 4 scalers have the same auto sync off timer			
K-Config Example			
Set the auto sync off timer to slow: `#SCLR-AS *, 2", 0x0D			

10.3.7.5 SHOW-OSD

Functions		Permission	Transparency
Set:	SHOW-OSD	End User	Public
Get:	SHOW-OSD?	End User	Public
Description		Syntax	
Set:	Set the OSD of the selected channel	# SHOW-OSD [SP]P1, P2[CR]	
Get:		# SHOW-OSD? [SP]P1[CR]	
Response			
Set / Get: ~[CR]@ SHOW-OSD [SP]P1, P2[CR] LF			
Parameters			
P1 – * (All)			
P2 – 1 (Off), 1 (On)			
Response triggers			
Response is sent to the com port from which the Set (before execution) / Get command was received After execution, response is sent to all com ports if SHOW-OSD was set any other external control device (button press, device menu and similar) or genlock status was changed			
Notes			
All 4 scalers have the same aspect ratio			
K-Config Example			
Show the OSD: `# SHOW-OSD *, 1", 0x0D			

10.3.7.6 W-BRD

Functions		Permission	Transparency
Set:	W-BRD	End User	Public
Get:	W-BRD?	End User	Public
Description		Syntax	
Set:	Set window border	#W-BRD <input type="checkbox"/> id,switch,ColSpace,p1,p2,p3 <input type="checkbox"/>	
Get:	Get window border status	#W-BRD? <input type="checkbox"/> id <input type="checkbox"/>	
Response			
Set / Get: ~ <input type="checkbox"/> r@W-BRD <input type="checkbox"/> id,switch,ColSpace,p1,p2,p3 <input type="checkbox"/> <input type="checkbox"/> LF			
Parameters			
id - 1 switch - 0 (Show), 1 (Only selected), 2 (Off) ColSpace - 0 (RGB) P1, p2, p3 - 1, 0, 0 (Red), 0, 1, 0 (Green), 0, 0, 1 (Blue), 1, 1, 0 (Yellow), 1, 0, 1 (Magenta), 1, 1, 1 (Grey)			
Response triggers			
After execution, response is sent to the com port from which the Set/Get was received After execution, response is sent to all com ports if W-BRD was set by any other external control device (button press, device menu and similar)			
Notes			
For Dual and Quad modes only			
K-Config Example			
Show red border: "#W-BRD 1,0,0,1,0,0",0x0D			

10.3.7.7 W-HUE

Functions		Permission	Transparency
Set:	W-HUE	End User	Public
Get:	W-HUE?	End User	Public
Description		Syntax	
Set:	Set picture hue	# W-HUE [SP]win_num,value[CR]	
Get:	Get picture hue	# W-HUE? [SP]win_num[CR]	
Response			
Set / Get: ~[nr]@ W-HUE [SP]win_num,value[CR LF]			
Parameters			
win_num – 1 (OUT A), 2 (OUT B), 3 (OUT C), 4 (OUT D), * (All) value – 0~100			
Response Triggers			
After execution, response is sent to the com port from which the Set/Get was received After execution, response is sent to all com ports if W-HUE was set by any other external control device (button press, device menu and similar)			
Notes			
Value limits can vary for different devices Value is a property of input connected to current window. Changing window input source might cause changes in this value (refer device definitions)			
K-Config Example			
Set OUT A hue to 65: "#W-HUE 1,65",0x0D			

10.3.7.8 W-SATURATION

Functions		Permission	Transparency
Set:	W-SATURATION	End User	Public
Get:	W-SATURATION?	End User	Public
Description		Syntax	
Set:	Set window contrast	# W-SATURATION [SP]win_num,value[CR]	
Get:	Get window contrast	# W-SATURATION? [SP]win_num[CR]	
Response			
Set / Get: ~[nr]@ W-SATURATION [SP]win_num,value[CR LF]			
Parameters			
win_num – 1 (OUT A), 2 (OUT B), 3 (OUT C), 4 (OUT D), * (All) value – 0~100			
K-Config Example			
Set OUT A saturation to 65: "#W-SATURATION 1,65",0x0D			

10.3.7.9 VW-POS?

Functions		Permission	Transparency
Set:	VW-POS	End User	Public
Get:	VW-POS?		
Description		Syntax	
Set:	Set 1x4 video wall position-H value	#VW-POS	SPposCR
Get:	Get 1x4 video wall position-H value	#VW-POS?	CR
Response			
~nn@VW-POS SPpos CR LF			
Parameters			
pos -- 999-0~999			
K-Config Example			
Set 1x4 video wall horizontal position to 45: "#VW-POS 45",0x0D			

10.3.8 Custom Commands

Command	Description
BEZEL	Set/get video resolution
EDID-AUDIO	Set/get EDID audio mode
IDV	Set visual indication from the device
LABEL	Set/get input/output label
VIEW-MOD	Set/get view mode

10.3.8.1 BEZEL

Functions		Permission	Transparency
Set:	BEZEL	End User	Public
Get:	BEZEL?	End User	Audio
Description		Syntax	
Set:	Set video wall bezel on/off H/V correction	#BEZEL	SPid,type,switch,H,VCR
Get:	Get video wall bezel switch H,V correction status	#BEZEL?	SPid,typeCR
Response			
~nn@BEZEL SPid,type,switch,H,V CR LF			
Parameters			
id - 1 type - 0 (Current H/V value), 1 (Max. H/V value), switch - 0 (Off), 1 (On) H, V - 0~Max			
Notes			
Setting bezel H/V to type=1 results in an error. Bezel is not supported for 480p/576p output Ignore bezel-H when in the 1x4 video wall mode			
K-Config Example			
Set the bezel to on and to 3: "#BEZEL 1,0,1,3,3",0x0D			

10.3.8.2 EDID-AUDIO

Functions		Permission	Transparency
Set:	EDID-AUDIO	End User	Public
Get:	EDID-AUDIO?	End User	Public
Description		Syntax	
Set:	Set EDID audio mode	#EDID-AUDIO <code>SP</code> mode <code>CR</code>	
Get:	Get EDID audio mode	#EDID-AUDIO? <code>SP</code>	
Response			
Set / Get: ~ <code>an</code> @EDID-AUDIO <code>SP</code> mode <code>CR LF</code>			
Parameters			
mode – 0 (LPCM 2CH), 1 (LPCM 6CH), 2 (LPCM 8CH), 3 (BITSTREAM), 4 (HD), 5 (DISABLE)			
K-Config Example			
Set audio EDID mode to HD: "#EDID-AUDIO 4",0x0D			

10.3.8.3 IDV

Functions		Permission	Transparency
Set:	IDV	End User	Public
Get:			
Description		Syntax	
Set:	Set visual indication from the device	#IDV <code>CR</code>	
Get:			
Response			
~ <code>an</code> @IDV <code>SP</code> OK <code>CR LF</code>			
Notes			
Using this command, some devices can light a sequence of buttons or LEDs to allow identification of a specific device from similar devices			
K-Config Example			
Set audio visual indication from the device: "#IDV",0x0D			

10.3.8.4 LABEL

Functions		Permission	Transparency
Set:	LABEL	End User	Public
Get:	LABEL?	End User	Public
Description		Syntax	
Set:	Set input/output label	# LABEL [SP]stage,stage_id,switch,label[CR]	
Get:	Get input/output label	# LABEL? [SP]stage,stage_id[CR]	
Response			
~[nn]@ LABEL [SP]stage,stage_id,switch,label[CR LF]			
Parameters			
stage – 0 (input), 1 (output) stage_id – for input: 1 (IN 1), 2 (IN 2), 3 (IN 3), 4 (IN 4); for output: 1 (OUT A), 2 (OUT B), 3 (OUT C), 4 (OUT D) switch – 0 (Off), 1 (On) label – A string of up to 12 characters			
Notes			
If stage_id is ignored and label string is empty, only do label on/off switch			
K-Config Example			
Set the IN 1 label to Blu-ray and turn it on: "# LABEL 0,1,1,Blu-ray",0x0D			

10.3.8.5 VIEW-MOD

Functions		Permission	Transparency
Set:	VIEW-MOD	End User	Public
Get:	VIEW-MOD?	End User	Public
Description		Syntax	
Set:	Set view mode	# VIEW-MOD [SP]mode[CR]	
Get:	Get view mode	# VIEW-MOD? [SP]	
Response			
~[nn]@ VIEW-MOD [SP]mode[CR LF]			
Parameters			
mode – 0 (Seamless matrix), 1 (Dual PIP), 2 (N/A), 3 (Quad), 4 (2x2 Video wall), 5 (Dual POP), 6 (1x4 Video wall), 7 (Independent matrix)			
K-Config Example			
Set view mode to Quad: "# VIEW-MOD 3",0x0D			

10.3.9 Miscellaneous Commands

Command	Description
CROP-POS	Set/get 1x4 video wall crop/position On/Off
CROP	Set/get 1x4 video wall crop-H value
MUTE-ANA	Set/get analog audio output mute
PICTURE-RST	Reset all the picture settings
PIP-POS	Set/get PIP sub-window position
PIP-SIZE	Set/get PIP sub-window size
PIP-SWAP	Swap PIP main/sub windows

10.3.9.1 CROP-POS

Functions		Permission	Transparency
Set:	CROP-POS	End User	Public
Get:	CROP-POS?	End User	Audio
Description		Syntax	
Set:	Set 1x4 video wall crop/position On/Off	#CROP-POS	SP switch CR
Get:	Get 1x4 video wall crop/position On/Off	#CROP-POS?	CR
Response			
~nn@CROP-POS SP switch CR LF			
Parameters			
switch - 0 (Off), 1 (On)			
K-Config Example			
Set crop to on: "#CROP-POS 1", 0x0D			

10.3.9.2 CROP

Functions		Permission	Transparency
Set:	CROP	End User	Public
Get:	CROP?	End User	Audio
Description		Syntax	
Set:	Set 1x4 video wall crop-H value	#CROP	SP crop CR
Get:	Get 1x4 video wall crop-H value	#CROP	CR
Response			
~nn@CROP SP crop CR LF			
Parameters			
crop - 0~400			
K-Config Example			
Set 1x4 video wall H crop value to 32: "#CROP 32", 0x0D			

10.3.9.3 MUTE-ANA

Functions		Permission	Transparency
Set:	MUTE-ANA	End User	Public
Get:	MUTE-ANA?	End User	Audio
Description		Syntax	
Set:	Set analog audio output mute	# MUTE-ANA [SP]channel,mute_mode[CR]	
Get:	Get analog audio output mute	# MUTE-ANA? [SP]channel[CR]	
Response			
~[nn]@ MUTE-ANA [SP]channel,mute_mode[CR LF]			
Parameters			
channel – 1 (OUT A), 2 (OUT B), 3 (OUT C), 4 (OUT D), * (All) mute_mode – 0 (Off, unmute), 1 (On, mute)			
Notes			
#MUTE has higher priority than #MUTE-ANA			
K-Config Example			
Set OUT B analog audio to mute: "#MUTE-ANA 2,1",0x0D			

10.3.9.4 PICTURE-RST

Functions		Permission	Transparency
Set:	PICTURE-RST	End User	Public
Get:			
Description		Syntax	
Set:	Reset all the picture settings	# PICTURE-RST [CR]	
Get:			
Response			
~[nn]@ PICTURE-RST [SP]OK[CR LF]			
K-Config Example			
Reset all picture settings: "#PICTURE-RST",0x0D			

10.3.9.5 PIP-POS

Functions		Permission	Transparency
Set:	PIP-POS	End User	Public
Get:	PIP-POS?	End User	Public
Description		Syntax	
Set:	Set PIP sub-window position	# PIP-POS [SP pip_no,pos CR]	
Get:	Get PIP sub-window position	# PIP-POS? [SP pip_no CR]	
Response			
Set / Get: ~[nr] @PIP-POS [SP pip_no,pos CR LF]			
Parameters			
pip_no - 1 (PIP A), 2 (PIP B) pos - 1 (Left top), 2 (Right top), 3 (Right bottom), 4 (Left bottom)			
K-Config Example			
Set PIP A position to left top: "#PIP-POS 1,1",0x0D			

10.3.9.6 PIP-SIZE

Functions		Permission	Transparency
Set:	PIP-SIZE	End User	Public
Get:	PIP-SIZE?	End User	Public
Description		Syntax	
Set:	Set PIP sub-window size	# PIP-SIZE [SP pip_no,size CR]	
Get:	Get PIP sub-window size	# PIP-SIZE? [SP pip_no CR]	
Response			
Set / Get: ~[nr] @PIP-SIZE [SP pip_no,size CR LF]			
Parameters			
pip_no - 1 (PIP A), 2 (PIP B) size - 1 (Large), 2 (Medium), 3 (Small), 4 (Off)			
K-Config Example			
Set PIP A size to large: "#PIP-SIZE 1,1",0x0D			

10.3.9.7 PIP-SWAP

Functions		Permission	Transparency
Set:	PIP-SWAP	End User	Public
Get:			
Description		Syntax	
Set:	Swap PIP main/sub windows	#PIP-SWAP <input type="checkbox"/> pip_no <input type="checkbox"/>	
Get:			
Response			
~nn@PIP-SWAP <input type="checkbox"/> pip_no <input type="checkbox"/> CR LF			
Parameters			
pip_no - 1 (PIP A), 2 (PIP B)			
K-Config Example			
Swap Main and PIP windows A: "#PIP-SWAP 1",0x0D			

10.3.10 Input/Output Resolutions Key

#	Resolution	#	Resolution
0	No signal (for input) Native (for output)	32	1280x768p75
1	640x480p59	33	1280x800p60RB
2	640x480p72	34	1280x800p60
3	640x480p75	35	1280x800p75
4	640x480p85	36	1280x960p60
5	720x400p70	37	1280x1024p60
6	720x480i59 (480i59)	38	1280x1024p60CVT
7	720x480i60 (480i60)	39	1280x1024p75
8	720x480p59 (480p59)	40	1360x768p60
9	720x480p60 (480p60)	41	1366x768p60RB
10	720x576i50 (576i)	42	1366x768p60
11	720x576p50 (576p)	43	1400x1050p60RB
12	800x600p56	44	1400x1050p60
13	800x600p60	45	1440x900p60RB
14	800x600p72	46	1440x900p60
15	800x600p75	47	1440x900p75
16	800x600p85	48	1600x900p60RB
17	1024x768p60	49	1600x1200p60
18	1024x768p70	50	1680x1050p60RB
19	1024x768p75	51	1680x1050p60
20	1024x768p85	52	1920x1080p23 (1080p23)
21	1152x864p70	53	1920x1080p24 (1080p24)
22	1152x864p75	54	1920x1080p25 (1080p25)
23	1280x720p25 (720p25)	55	1920x1080p29 (1080p29)

#	Resolution	#	Resolution
24	1280x720p29 (720p29)	56	1920x1080p30 (1080p30)
25	1280x720p30 (720p30)	57	1920x1080i50 (1080i50)
26	1280x720p50 (720p50)	58	1920x1080p50 (1080p50)
27	1280x720p59 (720p59)	59	1920x1080i59 (1080i59)
28	1280x720p60 (720p60)	60	1920x1080i60 (1080i60)
29	1280x720p60CVT	61	1920x1080p59 (1080p59)
30	1280x768p60RB	62	1920x1080p60 (1080p60)
31	1280x768p60	63	1920x1200p60RB

10.3.11 Error Codes

Error	Description
0	No error
1	Protocol syntax error, 1st char isn't '#'
2	Command not available in command list
3	Parameter is out of range
4	
5	
6	Protocol busy, UART ring buffer is overflow
7	
8	
9	Command is not available in current status

Limited Warranty

The warranty obligations of Kramer Electronics Inc. ("Kramer Electronics") for this product are limited to the terms set forth below:

What is Covered

This limited warranty covers defects in materials and workmanship in this product.

What is Not Covered

This limited warranty does not cover any damage, deterioration or malfunction resulting from any alteration, modification, improper or unreasonable use or maintenance, misuse, abuse, accident, neglect, exposure to excess moisture, fire, improper packing and shipping (such claims must be presented to the carrier), lightning, power surges, or other acts of nature. This limited warranty does not cover any damage, deterioration or malfunction resulting from the installation or removal of this product from any installation, any unauthorized tampering with this product, any repairs attempted by anyone unauthorized by Kramer Electronics to make such repairs, or any other cause which does not relate directly to a defect in materials and/or workmanship of this product. This limited warranty does not cover cartons, equipment enclosures, cables or accessories used in conjunction with this product.

Without limiting any other exclusion herein, Kramer Electronics does not warrant that the product covered hereby, including, without limitation, the technology and/or integrated circuit(s) included in the product, will not become obsolete or that such items are or will remain compatible with any other product or technology with which the product may be used.

How Long this Coverage Lasts

The standard limited warranty for Kramer products is seven (7) years from the date of original purchase, with the following exceptions:

1. All Kramer VIA hardware products are covered by a standard three (3) year warranty for the VIA hardware and a standard three (3) year warranty for firmware and software updates.
2. All Kramer fiber optic cables and adapters, active cables, cable retractors, all Kramer speakers and Kramer touch panels are covered by a standard one (1) year warranty.
3. All Kramer Cobra products, all Kramer Calibre products, all Kramer Minicom digital signage products, all HighSecLabs products, all streaming, and all wireless products are covered by a standard three (3) year warranty.
4. All Sierra Video MultiViewers are covered by a standard five (5) year warranty.
5. Sierra switchers & control panels are covered by a standard seven (7) year warranty (excluding power supplies and fans that are covered for three (3) years).
6. K-Touch software is covered by a standard one (1) year warranty for software updates.
7. All Kramer passive cables are covered by a ten (10) year warranty.

Who is Covered

Only the original purchaser of this product is covered under this limited warranty. This limited warranty is not transferable to subsequent purchasers or owners of this product.

What Kramer Electronics Will Do

Kramer Electronics will, at its sole option, provide one of the following three remedies to whatever extent it shall deem necessary to satisfy a proper claim under this limited warranty:

1. Elect to repair or facilitate the repair of any defective parts within a reasonable period of time, free of any charge for the necessary parts and labor to complete the repair and restore this product to its proper operating condition. Kramer Electronics will also pay the shipping costs necessary to return this product once the repair is complete.
2. Replace this product with a direct replacement or with a similar product deemed by Kramer Electronics to perform substantially the same function as the original product.
3. Issue a refund of the original purchase price less depreciation to be determined based on the age of the product at the time remedy is sought under this limited warranty.

What Kramer Electronics Will Not Do Under This Limited Warranty

If this product is returned to Kramer Electronics or the authorized dealer from which it was purchased or any other party authorized to repair Kramer Electronics products, this product must be insured during shipment, with the insurance and shipping charges prepaid by you. If this product is returned uninsured, you assume all risks of loss or damage during shipment. Kramer Electronics will not be responsible for any costs related to the removal or re-installation of this product from or into any installation. Kramer Electronics will not be responsible for any costs related to any setting up this product, any adjustment of user controls or any programming required for a specific installation of this product.

How to Obtain a Remedy Under This Limited Warranty

To obtain a remedy under this limited warranty, you must contact either the authorized Kramer Electronics reseller from whom you purchased this product or the Kramer Electronics office nearest you. For a list of authorized Kramer Electronics resellers and/or Kramer Electronics authorized service providers, visit our web site at www.kramerav.com or contact the Kramer Electronics office nearest you.

In order to pursue any remedy under this limited warranty, you must possess an original, dated receipt as proof of purchase from an authorized Kramer Electronics reseller. If this product is returned under this limited warranty, a return authorization number, obtained from Kramer Electronics, will be required (RNA number). You may also be directed to an authorized reseller or a person authorized by Kramer Electronics to repair the product.

If it is decided that this product should be returned directly to Kramer Electronics, this product should be properly packed, preferably in the original carton, for shipping. Cartons not bearing a return authorization number will be refused.

Limitation of Liability

THE MAXIMUM LIABILITY OF KRAMER ELECTRONICS UNDER THIS LIMITED WARRANTY SHALL NOT EXCEED THE ACTUAL PURCHASE PRICE PAID FOR THE PRODUCT. TO THE MAXIMUM EXTENT PERMITTED BY LAW, KRAMER ELECTRONICS IS NOT RESPONSIBLE FOR DIRECT, SPECIAL, INCIDENTAL OR CONSEQUENTIAL DAMAGES RESULTING FROM ANY BREACH OF WARRANTY OR CONDITION, OR UNDER ANY OTHER LEGAL THEORY. Some countries, districts or states do not allow the exclusion or limitation of relief, special, incidental, consequential or indirect damages, or the limitation of liability to specified amounts, so the above limitations or exclusions may not apply to you.

Exclusive Remedy

TO THE MAXIMUM EXTENT PERMITTED BY LAW, THIS LIMITED WARRANTY AND THE REMEDIES SET FORTH ABOVE ARE EXCLUSIVE AND IN LIEU OF ALL OTHER WARRANTIES, REMEDIES AND CONDITIONS, WHETHER ORAL OR WRITTEN, EXPRESS OR IMPLIED. TO THE MAXIMUM EXTENT PERMITTED BY LAW, KRAMER ELECTRONICS SPECIFICALLY DISCLAIMS ANY AND ALL IMPLIED WARRANTIES, INCLUDING, WITHOUT LIMITATION, WARRANTIES OF MERCHANTABILITY AND FITNESS FOR A PARTICULAR PURPOSE. IF KRAMER ELECTRONICS CANNOT LAWFULLY DISCLAIM OR EXCLUDE IMPLIED WARRANTIES UNDER APPLICABLE LAW, THEN ALL IMPLIED WARRANTIES COVERING THIS PRODUCT, INCLUDING WARRANTIES OF MERCHANTABILITY AND FITNESS FOR A PARTICULAR PURPOSE, SHALL APPLY TO THIS PRODUCT AS PROVIDED UNDER APPLICABLE LAW.

IF ANY PRODUCT TO WHICH THIS LIMITED WARRANTY APPLIES IS A "CONSUMER PRODUCT" UNDER THE MAGNUSON-MOSS WARRANTY ACT (15 U.S.C.A. §2301, ET SEQ.) OR OTHER APPLICABLE LAW, THE FOREGOING DISCLAIMER OF IMPLIED WARRANTIES SHALL NOT APPLY TO YOU, AND ALL IMPLIED WARRANTIES ON THIS PRODUCT, INCLUDING WARRANTIES OF MERCHANTABILITY AND FITNESS FOR THE PARTICULAR PURPOSE, SHALL APPLY AS PROVIDED UNDER APPLICABLE LAW.

Other Conditions

This limited warranty gives you specific legal rights, and you may have other rights which vary from country to country or state to state.

This limited warranty is void if (i) the label bearing the serial number of this product has been removed or defaced, (ii) the product is not distributed by Kramer Electronics or (iii) this product is not purchased from an authorized Kramer Electronics reseller. If you are unsure whether a reseller is an authorized Kramer Electronics reseller, visit our web site at www.kramerav.com or contact a Kramer Electronics office from the list at the end of this document.

Your rights under this limited warranty are not diminished if you do not complete and return the product registration form or complete and submit the online product registration form. Kramer Electronics thanks you for purchasing a Kramer Electronics product. We hope it will give you years of satisfaction.

KRAMER



P/N: 2900-300668



Rev: 3



SAFETY WARNING

Disconnect the unit from the power supply before opening and servicing

For the latest information on our products and a list of Kramer distributors, visit our Web site where updates to this user manual may be found.

We welcome your questions, comments, and feedback.

www.KramerAV.com
info@KramerAV.com