

Venue Receiver

TECHNICAL DATA

Six Channel Modular Receiver

Featuring Digital Hybrid Wireless® Technology

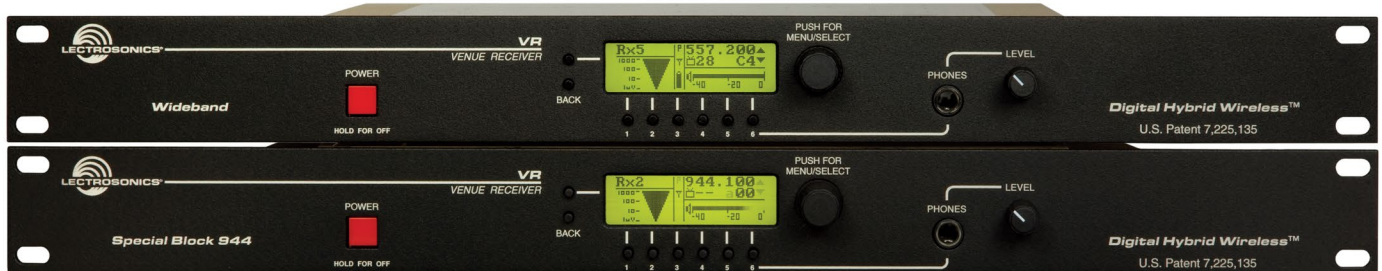

- Six-channel modular configuration
- Ratio, Antenna Phase or Frequency diversity reception
- 256 synthesized UHF frequencies per receiver module
- DSP-based pilot tone squelch control
- DSP emulation modes for compatibility with analog wireless systems in addition to the Digital Hybrid mode
- SmartNR™ noise reduction modes
- LecNet2 software interface included
- LCD interface for setup and monitoring
- USB and RS-232 computer interface

Digital Hybrid Wireless®

is a revolutionary design that combines digital audio with an analog FM radio link to provide both outstanding audio quality and exemplary, noise-free RF performance.

Using a patented algorithm to encode 24-bit digital audio information in the transmitter into an analog format, the encoded signal is then transmitted over an analog FM wireless link.

At the receiver, the signal is then decoded to restore the original digital audio. This process eliminates compandor artifacts and produces an audio frequency response flat to 20 kHz.

(US Patent 7,225,135)

The Venue Receiver is a modular solution that effectively deals with a congested RF spectrum with a variety of options that allows a system configuration to be idealized for a particular installation or application.

The receiver is comprised of several components:

- The master rack mount host assembly
- Up to six receiver modules
- Built-in antenna multicoupler with loop-thru output
- LecNet2 software for setup and control

Flexibility is the core concept of the design. The receiver modules can be operated separately, each with switched diversity reception for a total of six audio channels, or operated in pairs for more robust diversity reception with one audio channel per module pair. Combinations can also be used for special applications where some modules operate independently and others are paired.

The receiver modules are easy to change with no tools required. The wideband multicoupler allows the use of any frequency module in any position, except when modules are paired, they must be in adjacent positions as marked on the panel.

A major benefit of the design is the inclusion of a high quality antenna multicoupler. The multicoupler is actually a 1 in, 7 out splitter with six outputs for the receiver modules and an additional output as a "loop thru" for another Venue receiver. This allows multiple Venue receivers to operate from a single pair of antennas. Phantom power for remote antenna amplifiers is available from the multicoupler antenna inputs using internal jumpers.

Front Panel

The front panel provides an easy-to-use LCD interface for setup, and provisions for quick monitoring to assist in troubleshooting. In normal operation, the LCD shows RF and audio levels, diversity status, pilot tone status (where applicable) and transmitter battery status for all six receivers at the same time.

Individual screens for each receiver are also available at the touch of a button to provide additional information and setup adjustments.

A headphone jack and level control is provided for individual channel monitoring.



Rear Panel

The rear panel provides six balanced audio outputs on standard XLR connectors, 50 ohm BNC antenna inputs, 50 ohm BNC antenna outputs from the built in zero-gain multicoupler, power jack with a locking connector, USB port and RS-232 serial port for the computer interface.

The receiver assembly is powered from an external source at 10 to 18 volts DC through a locking connector, allowing the unit to operate from a wide variety of sources in stage, studio and mobile applications.



Receiver Modules

Two modules are available to further customize the configuration for specific applications. The VRS standard module has fixed front-end filters that cover its 25.5 MHz tuning range. The higher selectivity VRT module has tracking front-end filters that retune as the frequency is changed to stay centered over the selected frequency.

The modules are a triple conversion, frequency synthesized design, controlled by the microprocessor in the host assembly. A common DSP in the host assembly is used for all six receiver modules to decode the received signals and restore the digital audio. Using a single DSP results in a significant reduction in cost per channel.

The host assembly will handle up to six receiver modules via multi-pin connectors on the side of the main housing. The modules are held in place with snap-in retaining clips. The clips hold the modules firmly but are easy to remove without tools to make needed changes.



Built-in Antenna Multicoupler

Every Venue receiver has a built-in multicoupler that utilizes high current RF amplifiers and a Wilkinson type splitter for even signal distribution and high isolation between receiver modules. Optimally matched levels allow multiple receivers to be stacked and share a single pair of antennas - a significant savings in space and cost in multi-channel systems.

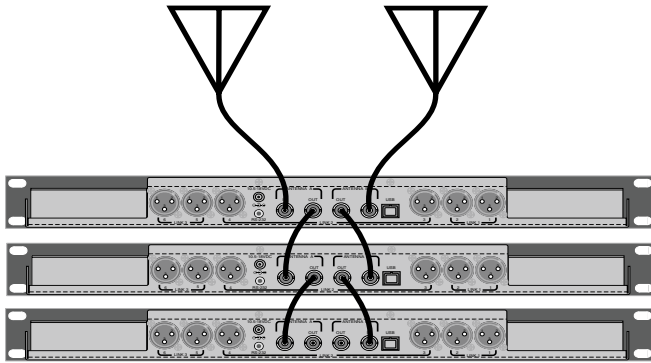

The built-in multi-coupler includes "loop through" outputs for stacking multiple Venue receivers.

Four versions are available for different applications:

- Wideband High (665 - 862 MHz)
(used outside the USA)
- Wideband Mid (537 - 768 MHz)
- Wideband Low (470 - 691 MHz)
- Special Block 944 (944 - 952 MHz)
(for licensed broadcasting use)

Phantom Power Jumpers

A remote amplifier can be powered directly from the Venue receiver through the coaxial cable. The ALP650 combines a broadband LPDA antenna with an amplifier, which is especially useful with the broad bandwidth of the Venue multicoupler. Jumpers are provided on the circuit board to enable and disable the phantom power. The top cover is removed with six screws and the jumpers are set as shown to enable the DC power.

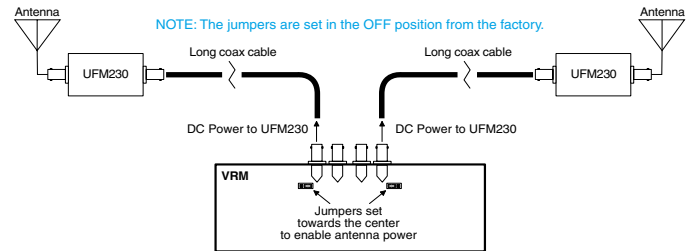

Computer Connections

The Venue receiver is typically connected to a computer via the USB port. Multiple receivers can be connected to a single computer using a USB hub. The receiver also provides an RS-232 port.

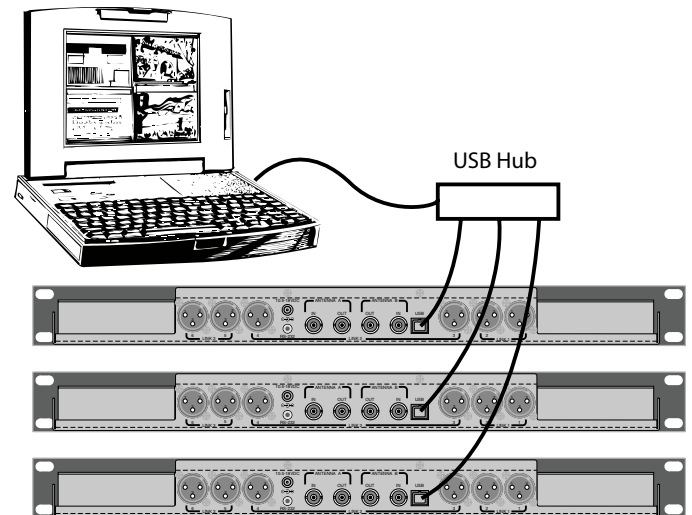

SmartTune™

An automated scanning process is also available that tunes a receiver module across its tuning range and selects a frequency with the least RF energy.



The process takes less than 30 seconds and the screen prompts the operator to turn on a transmitter for the last frequency selected before continuing. Once the transmitter is turned on, the process continues, prompting the operator to continue and select the next receiver to tune.



As the receiver is tuned to each frequency, the analysis evaluates RF energy within the channel as well as energy above and below the channel to avoid selecting a frequency adjacent to a high powered signal.

Compatibility Modes

The Venue receiver can be used to monitor IFB transmitter signals by switching one or more of the receiver modules to the IFB compatibility mode. Special DSP algorithms emulate the compandor in the IFB system and respond to the pilot tone signal from the transmitter to operate the receiver's squelch. In this mode, the Venue receiver behaves as though it is a native IFB receiver.

The IFB mode is useful for monitoring crew communications and for diagnostics. The spectrum scanning analyzer in the Venue can be used to find clear frequencies for the IFB system, followed by listening to the IFB transmitter to verify the setup.

The pilot tone frequencies in the IFB mode are different than the Digital Hybrid mode to preserve squelch reliability on both systems.

Other compatibility modes are also provided for use with analog Lectrosonics transmitters and several models from other manufacturers.

Setup and Control with the LCD

Setup options and adjustments can be made via the front panel LCD interface. Six channel select switches, two selection and navigation switches and a push button rotary encoder control are used with the LCD for setup.

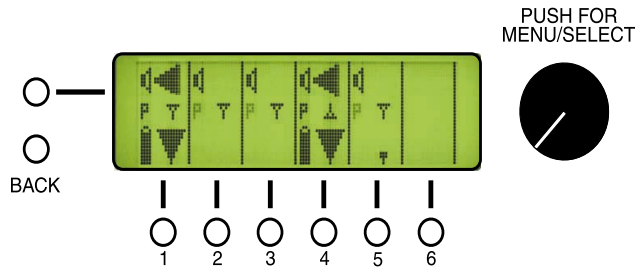

The LCD provides a variety of displays, plus an overview display showing transmitter battery status, RF and audio levels, pilot tone status and diversity switching activity for all six receivers. When receivers are paired for ratio or frequency diversity, the two channels are grouped as such in the overview display.

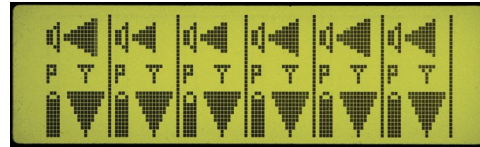

Pressing one of the receiver select buttons under the LCD switches to a detail screen for that module.

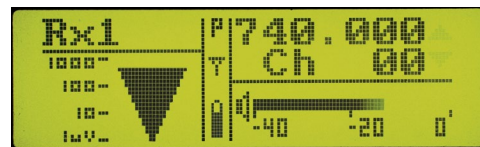

The scanning spectrum analyzer can also be run from the LCD, with manual or automatic location of clear operating frequencies. Scanning can be done with any of the modules to locate clear operating frequencies.



A variety of menus are available for all operating parameters. The menu items and adjustments are selected with the rotary encoder knob.

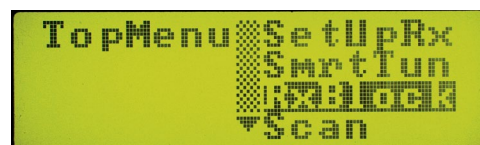

Setup and Control with LecNet2 Software

LecNet2 is a software interface for the Venue receiver that enables computerized setup, control and monitoring. The software will connect through USB or RS-232 ports on the computer and runs under Windows® 2000, XP or Vista operating systems.*

The main window in the software displays all six receiver modules installed in the assembly at the same time. The display includes frequency information, and audio and RF Levels are displayed real-time.

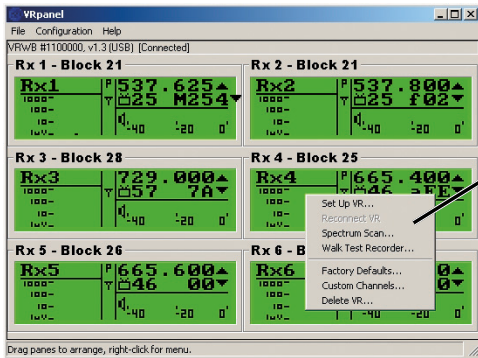

Right click for receiver setup and other functions

Right click the receiver pane to access individual module setup screens and other functions. The Setup Screen for one module allows full configuration of all settings.

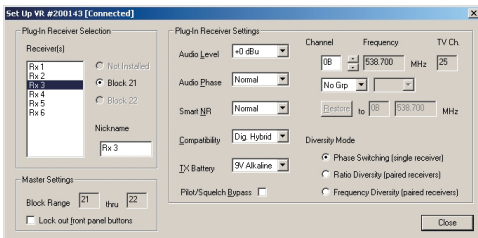

Multiple Venue receivers can be monitored and controlled at the same time.

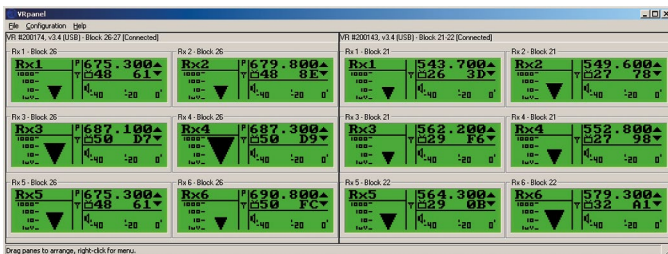

Popular touch screen control systems can also be configured for remote control and monitoring.

RF Spectrum Analyzer

Right-clicking anywhere in a Venue Receiver opens a pop up a menu with additional functions available for the associated Venue Receiver, including an RF spectrum scanner and walk test recorder.

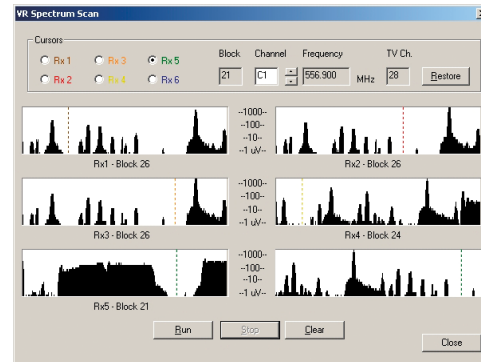

VRpanel Spectrum Scanner

The spectrum scanner provides a visual display of RF activity within the tuning range of the system to quickly locate clear operating frequencies. Frequency and switch settings are displayed for the selected receiver to simplify setup of the associated transmitter.

Walk Test Recorder

This convenient feature generates a visual “strip chart” of RF level during a walk test. Audio can be recorded simultaneously on the computer drive as the walk test is conducted. Mentioning transmitter locations during the walk test makes it easy to identify potential problem areas when the recordings are played back.

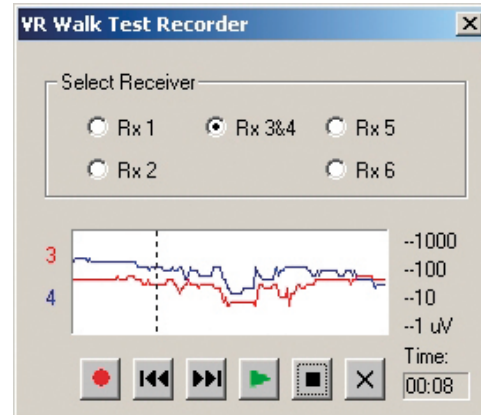

VRpanel Walk Test Recorder

*Windows® XP and Vista are registered trademarks of Microsoft Corp.

DSP-Based Pilot Tone

Pilot tone is a popular method of eliminating noise when a receiver is turned on without a transmitter signal. In this situation, interference can open the audio output squelch of the receiver and deliver loud noise into the sound system. A pilot tone is a separate signal or tone outside of the audio passband that controls the output squelch of the receiver. The receiver needs to detect both a valid RF signal and the pilot tone before the squelch will open.

There are several ways to implement a pilot tone. One common method is to generate a supersonic audio signal using a crystal. This is helpful, however, the receiver can pick up an invalid pilot tone through multi-signal IM (intermodulation) which can open the squelch.

The Digital Hybrid system design uses an ultrasonic pilot tone generated by the DSP to control the receiver squelch, with a different pilot tone frequency for each operating frequency. This eliminates squelch problems in multi-channel systems where a pilot tone signal can appear in the wrong receiver via IM.

Brief delays are also employed at turn-on and turn-off to eliminate thumps, pops or other transients that can occur when the power is switched on or off. The DSP generated pilot tone also eliminates fragile crystals which allows the receiver to survive shocks and mishandling much better than older crystal-based pilot tone systems.

Diversity Modes

The modular configuration enables several types of diversity reception for various applications. The modules can be used individually for switched diversity reception with each module delivering an audio output, or coupled into pairs for more robust diversity reception where each module pair delivers one audio channel.

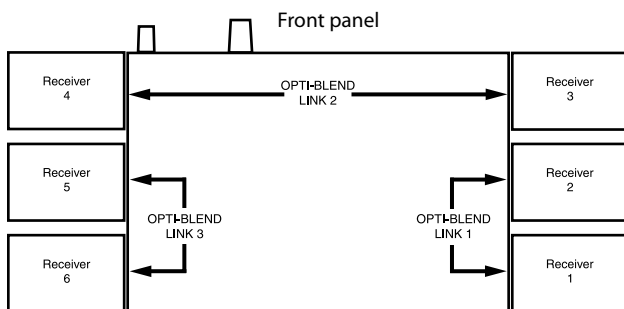

Antenna Phase Switching Diversity

Effective diversity reception can be implemented by combining the output of two antennas to feed a single receiver and controlling the phase of one antenna. This approach is commonly used for battery powered receivers where available power is limited. RF signal level is monitored continuously, and if the level falls below a certain threshold, the phase of one antenna is switched 180 degrees. If the signal is then stronger, the phase remains switched until the level falls below the threshold again. If the signal is weaker after the switch, the phase is switched back to the previous state and monitoring continues.

SmartDiversity™

This is a microprocessor controlled algorithm used in the Digital Hybrid system to enhance a phase switching diversity process. The algorithm monitors RF level, rate of change of RF level and audio content to determine the optimal time to switch. The phase switching is more aggressive when the average signal level is weak, and when the signal level falls rapidly compared to the average level. The algorithm also applies “opportunistic switching” to test for the best phase state during the silence of brief pauses in speech.

Each receiver module delivers its own audio channel, so the system can provide up to six channels per Venue main assembly.

OptiBlend™ Ratio Diversity

This is an audio combining process that mixes the audio outputs from two adjacent modules in a ratio controlled by comparing the RF signal strengths in the modules. Being a more robust type of diversity, it is normally used for critical applications such as a live broadcast where a dropout could have disastrous results.

Two modules are paired and tuned to the same frequency to pick up a single transmitter. The mode is set automatically as either module is switched to this mode. As the RF level in the two receivers is compared, more audio is mixed from the one with the stronger signal in an electronically damped panning process. The panning begins to take place at much higher RF levels than a phase switching technique to anticipate dropouts long before they threaten to produce noise in the audio signal.

Module pairs can be selected separately. For example, two modules could be paired for ratio diversity reception of a lead vocalist channel, while the other four modules could be used in the switched diversity mode, each delivering one audio channel.

Frequency Diversity

This is an automated redundancy process that pairs two adjacent receiver modules, however, the modules are tuned to different frequencies, each picking up its own matching transmitter. This mode provides robust diversity reception and added protection against battery failure. Common applications include redundant lavalier microphones for on-air talent in live broadcasts.

In this mode the microphones are positioned very close to each other to avoid comb filtering. The outputs of the receivers are mixed together in the same manner as the OptiBlend™ ratio diversity process, with the mix ratio controlled by comparing the RF levels in the modules.

Each pair of modules in this mode delivers one audio channel in the same manner as ratio diversity.

SmartNR™

A unique benefit of Digital Hybrid Wireless™ is a DSP-based algorithm that address high frequency noise in the audio. With a noise floor at -120 dBV and a frequency response to 20 kHz, high frequency noise in the source audio is more apparent than in conventional wireless systems.

The Smart Noise Reduction algorithm works by attenuating only those portions of the audio signal that fit a statistical profile for randomness or “electronic hiss.” Because it isn’t simply a sophisticated variable low pass filter as in earlier analog designs, much greater transparency is obtained. Desired high frequency signals having some coherence such as speech sibilance and tones are not affected.

The algorithm has three modes, selectable from the front panel LCD and the software GUI:

- OFF - no noise reduction is performed.
- NORMAL - the factory default setting; enough noise reduction is applied to remove most of the hiss from the mic preamp and some of the hiss from lavalier microphones.
- FULL - enough noise reduction is applied to remove most of the hiss from nearly any signal source of reasonable quality, assuming levels are set correctly at the transmitter.

Block Diagram

The Venue receiver uses a common microprocessor and DSP for all six receiver modules. This modular design reduces the cost per channel significantly, and saves rack space by combining a 7-way antenna multicoupler, power distribution and rack mount into a single 1RU assembly for all six channels.

Inside the main assembly the encoded radio signals picked up by the receiver modules are sent to the DSP for decoding and restoration of the 24-bit digital audio signals generated in the transmitters.

The microprocessor communicates with the operator through the front panel controls, and the USB and serial ports when connected to a computer. It also sends and receives control signals and data from the receiver modules and the DSP.

The DSP handles the “number crunching” to restore the digital audio from the encoded signals and communicates pilot tone status to the microprocessor. Once the digital audio is restored, it is finally converted to analog and delivered to the outputs, with control signals from the microprocessor setting the output levels.

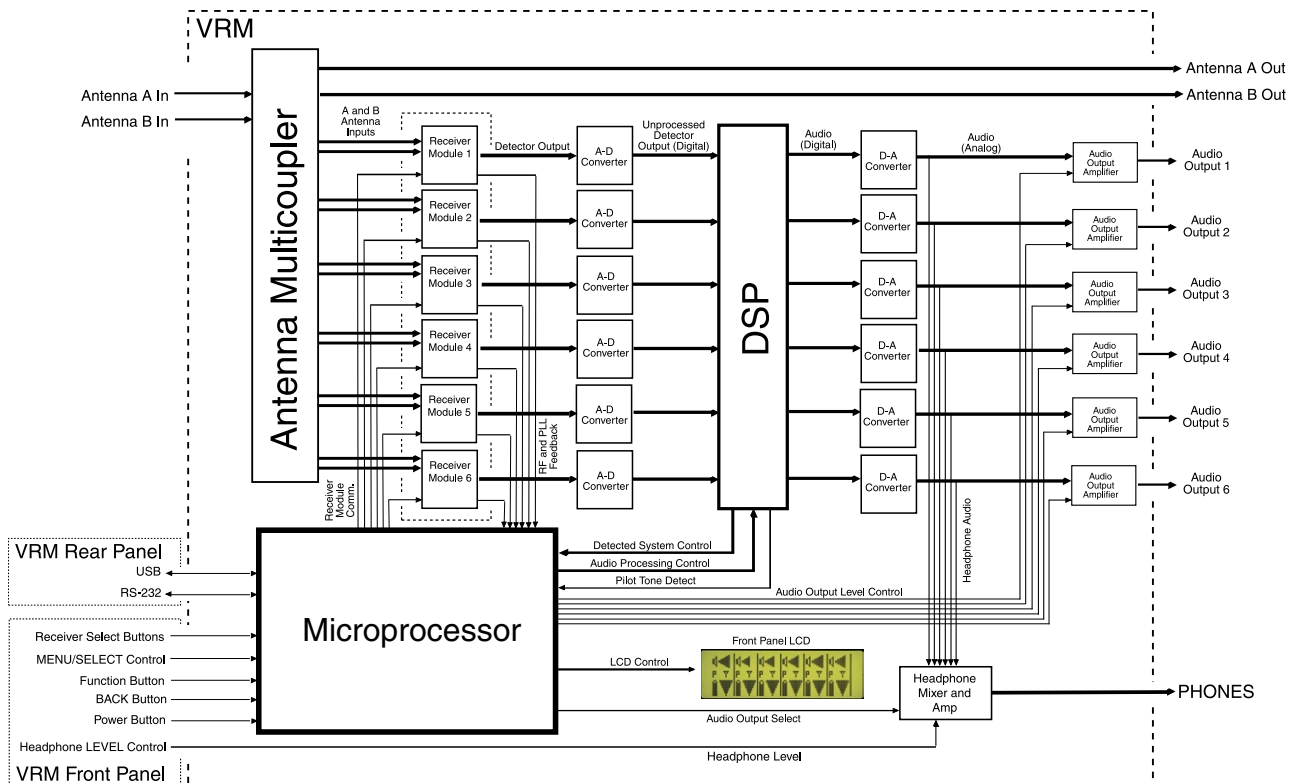

Specifications

Operating Frequencies (MHz) for Receiver Modules:

Block 470	470.100 - 495.600
Block 19	486.400 - 511.900
Block 20	512.000 - 537.500
Block 21	537.600 - 563.100
Block 22	563.200 - 588.700
Block 23	588.800 - 607.900 and 614.100 - 614.300
Block 24	614.400 - 639.900
Block 25	640.000 - 665.500
Block 26	665.600 - 691.100
Block 27	691.200 - 716.700 (outside USA)
Block 28	716.800 - 742.300 (outside USA)
Block 29	742.400 - 767.900 (outside USA)
Block 606	606.000 - 631.500
Block 944 (VRS only)	944.100 - 951.900

Digital latency: • 1.5 mS (receiver only - hybrid mode)
 • 3.0 mS (receiver and transmitter in hybrid mode)
 • 3.0 mS (receiver only - analog compatibility mode)

The 3.0 mS latency in analog compatibility mode time aligns the audio from analog and hybrid transmitters when they are used together in a Venue system.

Frequency selection: 256 frequencies in 100 kHz steps per
 25.5 MHz frequency block

Channel Spacing: 100 kHz

Dual Block Range: Built in antenna multicoupler covers a two block range.

Pilot tone: 25 to 32 kHz; 5kHz deviation; unique pilot tone frequency for each selected carrier frequency (Hybrid mode)

Deviation: ± 75 kHz (max) (Hybrid mode)

Receiver Type: Triple conversion superheterodyne

Frequency Stability: ±0.001 %

Multicoupler Bandwidth:

Wideband High:	665 - 862 MHz
Wideband Mid:	537 - 768 MHz
Wideband Low:	470 - 691 MHz
Special Block 944:	8 MHz; 944 - 952 MHz

Front End Bandwidth:

VRS Module:	30 MHz @ -3 dB
VRT Module:	11 MHz @ -3 dB

Sensitivity (20 dB Sinad): 0.9 uV

AM Rejection: >60 dB, 2 uV to 1 Volt

Image and Spurious

Rejection: 85 dB

Third Order Intercept: VRS: +0 dBm, VRT: +6 dBm

Diversity Methods: Switched, ratio and frequency

FM Detector: Digital pulse counting detector @ 300 kHz

Audio Performance (overall system):

Frequency Response: 32 Hz to 20 kHz (+/-1dB), overall system (400 Series mode)

THD: 0.2% (typical) (400 Series mode)

SNR at receiver output (dB) In Hybrid operating mode:

SmartNR	No limiting	w/ Limiting
OFF	103.5	108.5
NORMAL	107.0	111.5
FULL	108.5	113.0

(Note: the dual envelope "soft" limiter provides exceptionally good handling of transients using variable attack and release time constants. The gradual onset of limiting in the design begins below full modulation, which reduces the measured figure for SNR without limiting by 4.5 dB).

Input Dynamic Range: 125 dB (with full transmitter limiting)

Audio Output Level: -15 dBu to +8 dBu, in 1 dB increments

LCD: 122x32 graphical display

Power Requirements: 10 to 18 VDC; 17.2 W max. (1.72 A @ 10 VDC to 1.05 A @ 18 VDC)

Weight: VRM with 6 VRS modules: 4.28 lbs. (1946 g)
 VRM with 6 VRT modules: 4.45 lbs. (2018 g)

Dimensions: 19"W x 1.75"H x 7.75"D (panel to rear jacks)
 (48.26 cm x 4.45 cm x 19.67 cm)

Specifications and Features subject to change without notice.

Note: Some specifications apply only when the receiver is operating in the Digital Hybrid (400 Series) mode.

