



PEM-1000

Wireless Personal In-Ear Monitor
100 CH UHF Synthesized



OWNER'S MANUAL

Contents

Contents	2
Introduction	2
Using This Manual	2
Warning	3
System Features	4
Quick User Controls Guide.....	5
Operation	
PEM-1000T Transmitter	8
PEM-1000R Receiver	9
Multiple System Operation	12
Caution During Operation.....	13
Specifications	14
Frequency Table	15
Service.....	16
One Year Limited Warranty	17

Introduction

Thank you for purchasing a Nady PEM-1000 Wireless Personal In-Ear Monitor System and congratulations on your choice. This PEM-1000 offers all of the advantages of wireless in-ear monitoring—mobility, more focused audio, freedom from feedback, and elimination of transport issues associated with conventional floor monitors—as well as the long-term health benefits of safe listening levels. For the first time, a wireless in-ear monitor system combines state-of-the-art advanced frequency synthesized UHF technology, high-end performance, ease of use, and unprecedented affordability. The PEM-1000 offers a choice of 100 user selectable UHF channels for the transmitter and receiver(s), as well as stereo (MPX system) or mono mode transmission. This system is indispensable for live-stage music performance, and is loaded with features previously found only in units costing several times more.

Using This Manual

This booklet gives instructions for the operation of the PEM-1000 Wireless In-Ear Monitor System. Please read the instructions for your system completely before operating unit. This manual first lists the features of the PEM-1000, and then takes you step-by-step in explaining how to operate your new system, for the transmitter and receiver(s). Each section gives you detailed operating instructions. Also included in this manual are system specifications and servicing information.

Warning

**USING THIS SYSTEM AT EXCESSIVE VOLUMES CAN CAUSE PERMANENT HEARING DAMAGE.
ALWAYS USE A VOLUME LEVEL AS LOW AS POSSIBLE.**

The Occupational Safety Health Administration (OSHA) has established the following guidelines for maximum time exposure to sound pressure levels (SPL) before hearing damage occurs:

90 dB SPL @ 8 hours
95 dB SPL @ 4 hours
100 dB SPL @ 2 hours
105 dB SPL @ 1 hour
110 dB SPL @ 1/2 hour
115 dB SPL @ 15 minutes

Avoid exposure to 120 dB SPL or greater or irreversible ear damage may result.

(Note: It is difficult to measure the SPL present at the eardrum in live sound applications. The volume present will be affected by the level setting of your PEM-1000R, the ambient stage sound from your other instruments and speakers, and the quality of and fit of your in-ear speakers.)

Always avoid prolonged listening at excessive sound pressure levels. Use the following guidelines to use this system safely:

1. Turn up the volume to your earphones only enough to hear properly. The PEM-1000 can provide a high quality monitor mix at significantly lower decibel levels than floor monitors. Whenever possible, use the system with the limiter in the PEM-1000R receiver ON.
2. Just as with any in-ear monitor system, The PEM-1000 works best when used exclusively by all performers on stage (without any wedges or side monitors). The high sound pressure levels produced by floor monitors (especially if the band plays loud) can bleed through the in-ear monitor ear-buds and in the worst cases, hinder their effectiveness. Experiment with your overall mix to get the maximum benefit from your PEM-1000.
3. Turn down the volume immediately if you experience any pain or hearing discomfort or ringing in the ears after use.
4. Have an audiologist check your hearing and ears regularly. If you experience any wax buildup in your ears, do not use the system until an audiologist examines your ears.
5. Wipe the earphones with an antiseptic before and after use to avoid infection. Stop using the earphones if they cause discomfort or infection.



An equilateral triangle enclosing an exclamation point is intended to alert the users to the presence of important operating and service instructions in the literature enclosed with this unit.

System Features

- Available on selected frequency bands within the UHF band for interference-free, long-range performance (up to 8 systems can be operated simultaneously, depending on country and frequency band)
- System consists of PEM-1000T transmitter and one bodypack PEM-1000R receiver, both of which offer 100 channels user select-ability. Any number of additional receivers can also be operated with the same transmitter if they are all set to the same channel.
- AUTO-SCAN on receiver unit for easily locating clear channels or manual choose Group/Channel on transmitter
- IR (Infrared) synchronization both ways interface between receiver and transmitter
- User-friendly menu operation with more control options shown in LCD display
- Proprietary companding circuitry for wide Dynamic Range and clear, natural sound
- Operating Range: Up to 500 feet typical (depending on site conditions)
- Rugged, foam-padded traveling case provides easy, safe transport and storage

PEM-1000T Transmitter

- Rugged, all metal half-rack that can be rack mounted singly or side-by-side with optional rack kits
- Front panel features stereo headphone monitor output jack and volume control, select button for choosing one of 100 UHF channels, Left/Right 5-segment audio input level displays, LCD channel display, and IR SYNC to system receivers
- Back panel provides BNC jack for the detachable antenna, a combo 1/4" TRS unbalanced, and balanced XLR jacks for Left and Right Line inputs, Left and Right 1/4" TRS unbalanced loop outputs
- Externally powered by AC-DC power adapter

PEM-1000R Receiver

- Portable bodypack receiver features a power switch switchable with built-in volume output level control, select button for choosing one of 100 UHF channels, LCD channel display, stereo/mono, Signal/Low Battery LED indicator.
- Receiver has AUTO-SCAN for an open channel and IR SYNC to system transmitter
- Handy Mute Button for muting audio if desired during use
- Operates up to 8 hours (depending on volume) on 2x1.5V AA alkaline batteries
- Each receiver is supplied with a pair of miniature, lightweight (yet powerful) in-ear speakers with soft rubber mounts, designed for "custom" form-fitted comfort and optimum acoustic transfer and isolation.
- Rear clip can be rotated 180° for attaching receiver either vertically up or down position.

Quick User Control Guide

Transmitter Front Panel

- 1. Earphone Output 1/4" jack:** Connecting stereo earphones for monitoring output signal
- 2. Volume Knob:** Adjusting the volume clock-wise (MAX), counter clock-wise (MIN)
- 3. Left/Right Source Audio Input Level LCD tree:** Indicates if audio input source level is optional
- 4. LCD display:** Displaying Channel/Frequency, and other status
- 5. Infrared Receptor/Sender LED:** Synchronizes operating frequency between transmitter and receiver as selected by either
- 6. Manual UP selecting button:** Manual setting up with up direction
- 7. Set Up Button:** Set up the functions of the transmitter/ scroll through the menu list
- 8. Manual DOWN selecting button:** Manual setting up with down direction
- 9. SYNC Button:** Press this button down can set up the transmitter and receiver's infrared link and connection
- 10. Power Switch:** Press momentarily to turn ON and for a few seconds to turn unit OFF

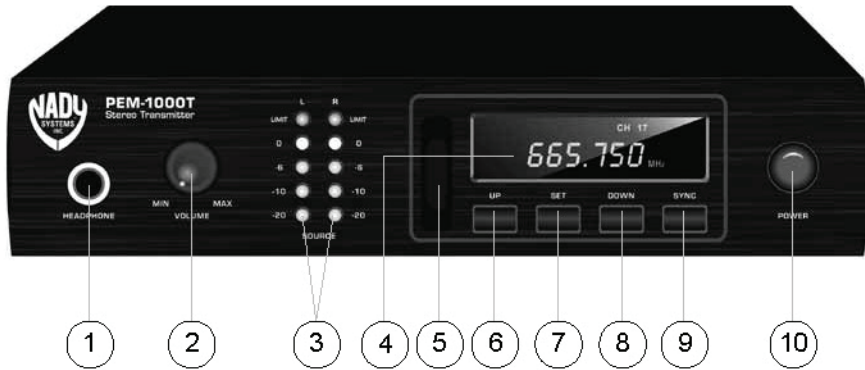

Transmitter Rear Panel

- 11. Transmitter Antenna BNC connector:** Connect antenna before use
- 12 Left Channel Loop Out:** 1/4" jack provides parallel unbalanced pass-through output of input source signal to other devices
- 13. Right Channel Loop Out:** see above
- 14. Left Channel Audio Source Input:** Combo XLR/1/4" jack, mono
- 15. Right Channel Audio Source Input:** Combo XLR/1/4" jack, mono
- 16. DC Input Jack:** Connects AC/DC adapter power supply (center of jack is + polarity)

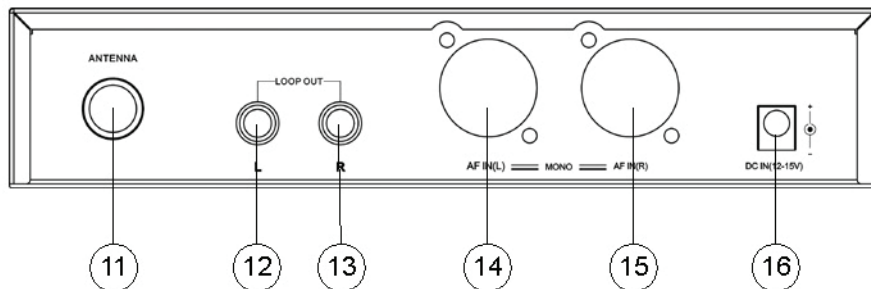

Bodypack Receiver

- 17. Power and Volume Control:** Combo power ON/OFF switch and earphones volume adjust
- 18. Earphone Out:** 1/8" (3.5mm) jack for connecting monitoring earphones
- 19. Antenna:** permanently attached
- 20. RF Signal LED Indicator:** Lights RED when receiving transmitter's signal
- 21. LCD Display:** Displays selected frequency and battery life status (0 Bar=Empty)
- 22. Infrared Receptor/Sender LED:** Synchronizes operating frequency between transmitter and receiver as selected by either
- 23. Stereo/Mono Switch:** Selects either stereo or mono output to earphones
- 24. Limiter Switch:** Select to limit the audio output level to earphones
- 25. Battery Compartment:** Holds 2 x AA Batteries
- 26. Battery Compartment Door:** Covers batteries and selection buttons
- 27. LOCK Button:** Locks the receiver controls to prevent accidental adjustment
- 28. SYNC Button:** Press to download receiver's Autoscan selected frequency to receiver via infrared link for frequency synchronization
- 29. AUTOSCAN:** Press to automatically find open channel
- 30. MUTE Button:** For muting the audio output to the headphone
- 31. Belt Clip:** Rotates 180° for attaching to belt with receiver's top panel in either up or down position

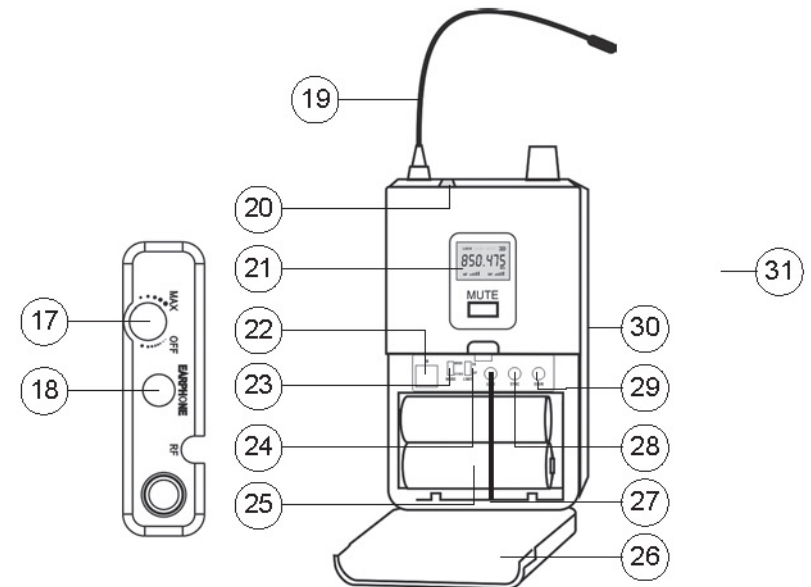

Rack-mounting the PEM-1000T

- 32. **RKT-11:** Optional rackmount kit for rackmounting a single unit. Includes front antenna mount, jack and connecting cable.
- 33. **RKT-21:** Optional rackmount kit for rackmounting two units side-by-side.
- 34. **AC/DC Adapter:** DC-12V/1000mA (110-240VAC, auto select), plugs into transmitter **DC Input Jack (16)**
- 35. **Antenna:** screws onto transmitter **Antenna BNC connector (11)**

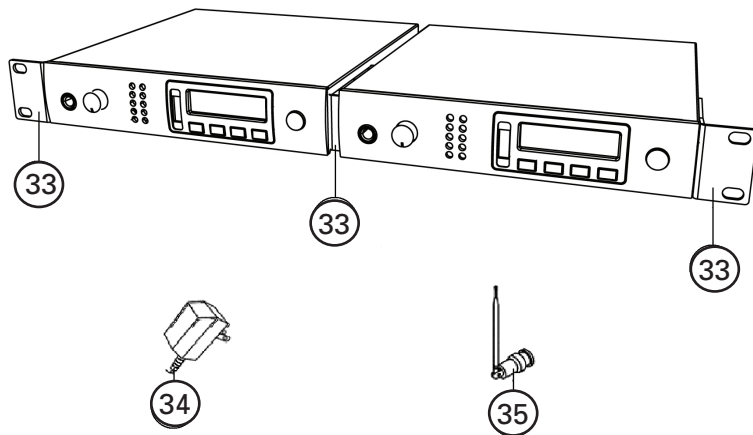
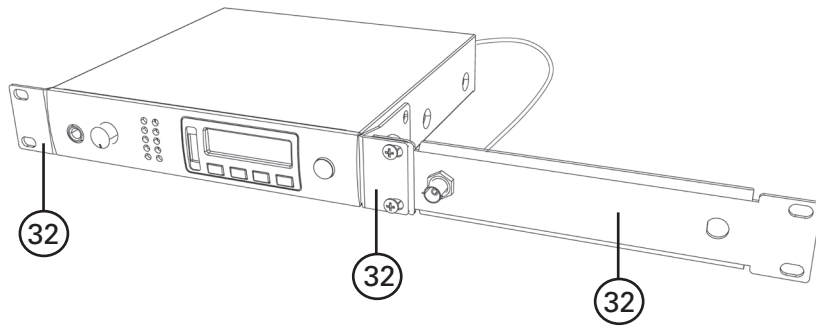

Operation

PEM-100T Transmitter

1. Rack-mounting the transmitter

The PEM-1000T requires no installation and can be used on any flat surface. However, in some applications rack mounting is preferred. There are 2 options available for rack-mounting the PEM-1000T transmitter: singly or side-by-side with another PEM-1000T transmitter.

- Single mounting: The optional **RKT-11 Rack Kit (32)** can be attached with the screws provided on the front of the side panels to enable rackmounting a single PEM-1000T transmitter. Includes front antenna mount, jack and connecting cable.
- Side-by-side dual mounting: The optional **RKT-21 Rack Kit (33)** can be attached with the screws provided on the front of the side panels to enable rackmounting two PEM-1000T transmitters.

(Note: Do not mount the transmitter(s) in a rack directly above an amplifier or other source of high heat—this could degrade the performance of the PEM-1000T. Always ensure adequate airflow and heat dissipation in any rack configuration.)

2. Antenna

Connect the **Antenna (35)** or optional remote antenna on the back panel to the **Antenna Jack (11)**. Optimal antenna position is vertical. For maximum range, it is always best to maintain a line of sight (no obstructions) between the transmitter antenna and the receiver(s) at all times whenever possible.

3. Powering the Transmitter

Plug the 12V-15V/1000mA **DC Adapter (34)** provided into the **DC Input Jack (16)** on the back of the receiver. Then plug the power supply into an AC outlet. Press the **Power Switch (10)** once to turn on the transmitter. The backlight **LCD Display (4)** will now light and the transmitter is operational. The LCD display will be lit up and meantime all the relative information will be displaying on the screen, when the PLL circuit has been locked the transmitter will start to transmit the signal.

4. Connecting the Audio Input

The PEM-1000T transmitter features a 1/4" TRS unbalanced and balanced XLR for the **LEFT Input (14)** and **RIGHT Input (15)** combo sockets for inputting Line Level. The pass through LEFT and RIGHT output 1/4" TRS unbalanced for daisy chain audio. The audio signal input can be chosen to be stereo or mono signal. If mono, the input should be gone through AF IN **RIGHT input (15)** using XLR balanced input or 1/4" unbalanced plug, the socket is a combo socket to be able to use the both plugs but only one a time.

(Please note: The signal input level is line level, if need to input Mic level, then it has to be amplified before inputting, otherwise the sensitivity is not enough, we recommend to first connect with the monitoring output on the mixer first.)

5. Set the proper audio input level

The strength of the audio input signal will be displaying on the two **LED Indicators (3)** on the front-left panel. Adjusting the output level properly makes three LEDs to be lit up. When input level is higher, the four LEDs lit up. If more than 4 LEDs are lit up the fifth red LED will be lighted to show the input signal has been too strong. So, adjust the input properly to make sure the S/N ratio and dynamic range are the best to avoid distortion.
*(Note: As when making any connection, make sure that the PEM-1000T **Volume Knob (2)** and the console output levels are set at minimum volume before plugging into the transmitter. This will avoid possible loud transients in the PEM-1000R receiver if it is already turned on, and with earphones plugged into the user's ears.)*

6. Monitoring on audio signal and connection with earphones

The sound technician can monitor the signal being transmitted with a pair of wired headphones via the stereo 1/4" TRS **Earphone Output Jack (1)**. The volume can be adjusted as desired with the **Volume Knob (2)**. Both the left and right channels of a stereo signal are adjusted simultaneously by this control in the same manner. To monitor the sound, plug the stereo earphones into the earphone/headphone output jack, the earphone jack must be stereo 1/4" at the same time please rotate the volume knob to adjust the proper monitoring volume.

(Please note: In order to protect your ears, the volume must be adjusted properly, it can't be too loud, and if too loud the earphone output will be distorted.)

7. Transmitter function set up procedure:

SET Button (7): This button has five functions/menus and works conjunction with the **UP (6)**, or **DOWN (8)**, they are explained as below:

MAIN DISPLAY→SET CH→MODE→GROUP→RF PWR→AF IN→EXIT

SET Button Illustration:

- Press the SET Up Button to select **SET CH** menu, press Manual UP or DOWN button to increase or decrease the frequency to get the ideal one, meanwhile you can see the frequencies are changed per 125 KHz on the LCD displaying screen.
- Press the SET Up Button again to select **MODE** menu, press Manual Up button to be in Stereo mode and press Manual Down button to be in Mono mode (only R input is used).
- Press the SET Up Button third time to enter **GROUP** menu, press Manual Up or Down to increase or decrease the frequencies to get the wanted frequency, meanwhile you can see the channel numbers are changed per 10 CH a time on the LCD displaying screen.
- Press the SET Button the fourth time to select **RF PWR** menu, press Manual Up or Down to choose the emission power HI or LOW. It has been preset to be LOW power at 10mW, HI is 100mW. Please kindly check with your local wireless transmission control gets the relative regulation on its allowable power limit.
- Press the SET Button the fifth time entering input **AF IN** menu, press Up or Down to choose the max audio input level, either +4dB or +10dB.
- Press the SET Up Button again to **EXIT** menu, in this preset menu after 8 seconds the unit will be existed to the default main menu automatically.

PEM-1000R Receiver

1. Using the battery and the battery automatically management system

The receiver requires two pieces of normal or rechargeable **AA-Batteries (25)**. Insert the batteries into the **Battery Compartment (25)**. Observe the correct polarity and close the **Battery Door (26)**. The normal AA battery can run more than 8 hours. When the battery voltage is less than 1.9V the power management system will power off the unit automatically to protect the batteries from leakage.

(Notes: The normal batteries must be with good quality and without leakage. The rechargeable battery must be the Ni-H battery without memory effect but large capacity.)

2. Earphone connection

Connect the stereo monitoring earphones jack into the receiver.

Plug in the stereo monitoring earphone jack to the 1/4" stereo **Earphone Jack (18)**, or can also connect any normal earphone or put the output terminals to be connected with other audio equipments' audio signal input. *(Please note: The earphone output jack is stereo output, please pay attention to the fact that the connecting plug must be stereo plug, if it is the mono jack, it will be possible to get short-circuit on the output and then damage one side of the earphone output.)*

(Note: Wipe the earphones and rubber mounts with an antiseptic before and after each use to avoid infection. Stop using the earphones if they are causing discomfort or infection.)

3. Power on the unit and volume control

Rotate the power and **Volume Knob (17)** on the top of the receiver clockwise to power on the unit, meanwhile the **LCD Display (21)** is showing out the working frequencies and battery status. After the unit is on, continuously rotate the volume knob in clockwise direction to get the volume louder and turn counter clockwise to reduce the volume.

(Please note: When the battery is weak or too little remaining, the unit can't be powered on, it is a must to change new batteries or to check if the batteries are well installed with right polarity.)

4. Sound mode switch

Stereo-Mono Switch (23) can be used to choose if the current earphone should be stereo output or mono output, when the stereo is chosen, it must work with the transmitter and the transmitter should be tuned to be stereo too. *(Please note: When the stereo output mode is chosen, the sound performance is good while the S/N ratio is not good as when choosing mixed sound in mono mode output.)*

5. Sound Limit mode switch

The **Limit Switch (24)** is used to keep the headphone output to a limited level.

6. RF signal LED Indicator

When the **RF LED Indicator (20)** has been lit up, it means there has gotten transmitter's signal. If the interference signals at the same frequency, it will also light up. To eliminate the interference please switch to the non-interference frequency.

7. Frequency setup for either from the Transmitter-Receiver or Receiver-Transmitter

For Transmitter-Receiver: Open the **Battery Compartment (26)** of the receiver, get the **Infrared Receiving IR (22)** to be seen, and should be pointing to the transmitter **Infrared Transmission Window (5)**, press the **SYNC Button (9)** on the transmitter until the receiver has gotten the same frequency as the transmitter. Now the system has been set up successfully set up. Close the receiver's battery compartment. If you have more than one receiver, use this procedure to sync the additional receiver.

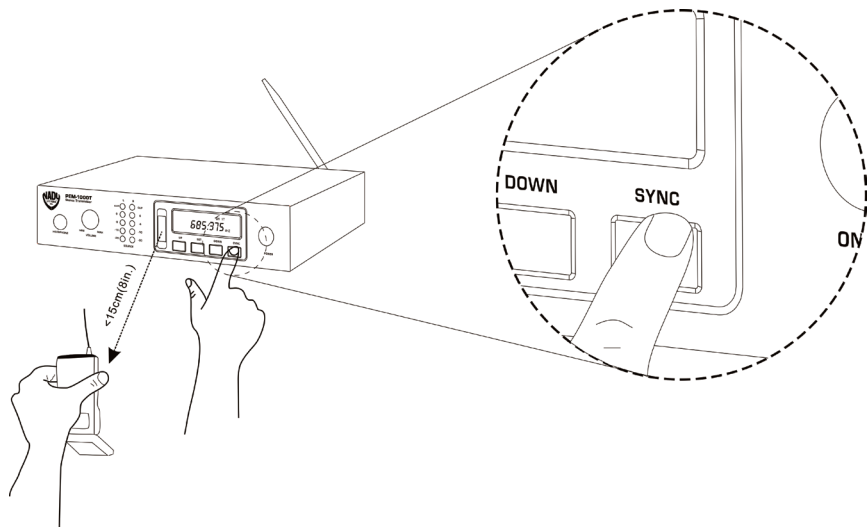

For syncing Receiver-Selected Frequency to Transmitter: Press the receiver **Auto-Scan Button (29)** to locate an open frequency/channel. Point the **Receiver Infrared IR receptor/Sensor(22)** at the transmitter **Infrared Transmission Window (5)** and press the **SYNC Button (28)** on the receiver until the transmitter's **LCD Screen (4)** displays the same frequency as the receiver's **LCD Screen (21)**.

8. The receiver's LCD display can be locked with the **LOCK Button (27)** to prevent accidental adjustment, or to unlock it to make an adjustment later. The "LOCK" icon will be displayed on the LCD screen in lock mode only. Push the Lock button to unlock.

9. The headphone audio can muted temporarily by pressing the **MUTE Button (30)**. Press again to un-mute. The "MUTE" icon will be displayed on the LCD screen in mute mode only.

10. Wearing the Bodypack Receiver.

The **Belt Clip (31)** rotates 180° for attaching to belt with receiver's top panel in either up or down position as pictured below.

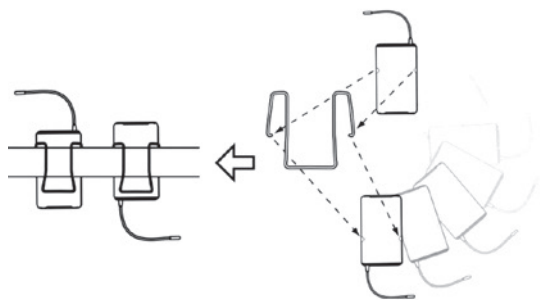

Multiple System Operation

Selecting a Channel/ Multiple System Operation

Both the PEM-1000T transmitter and PEM-1000R receiver offer a choice of 100 channels in the UHF band. Select an open frequency, that doesn't interfere with any other PEM-1000 or UHF wireless Mic system you are also using, by pushing the SET Up Button (7) and Manual Up (6) or Manual Down (8) buttons on the front panel of the PEM-1000T until the channel you want is displayed on the LCD Display (4). You will also need to select the same channel for the transmitter (see Transmitter Operation instructions above). If different mixes are required for the different performers, additional PEM-1000T transmitters and receivers set to other channels must also be used, and each transmitter must be fed a different mix from the console as desired. Depending on the band(s) you are using and open channel availability within the band(s), up to 8 PEM-1000 systems on different frequencies can be operated simultaneously to provide multiple discrete mixes to the performers.

[Note: After selecting a frequency on the transmitter, you must also check with the receiver to ensure that the chosen channel is open (i.e., no other transmissions from other sources, such as UHF TV channels in your area, operating at the same frequency). Turn off the PEM-1000T transmitter, and monitor the signal from the PEM-1000R (see PEM-1000R instructions page). It should be silent. For optimum operation and range, if you receive any transmissions or static you must choose another channel that is clear.]

[Note: If, after you complete the set-up, you experience interference or unsatisfactory audio performance, change the channel until the problem goes away. In the extremely rare circumstance that such a problem persists, turn off all UHF wireless Mic being used or move their receivers physically away from the PEM-1000T transmitter. In some instances, UHF wireless Mic and the PEM-1000 system can interact if they are too close in frequency. Contact the NADY SYSTEMS Service Department for further information if necessary (see SERVICE)]

Multiple Monitor Mixes

Any number of PEM-1000R receivers can be used with a single PEM-1000T transmitter set to the same channel. Although there are individual controls on each receiver allowing different levels of volume, each receiver will receive the same transmitted monitor mix (see Selecting Stereo or Mono Mode Reception above for exceptions). If different mixes are required for the different performers, additional PEM-1000T transmitters and receivers set to other channels must also be used, and each transmitter must be fed a different mix from the console as desired.

(Note: Never set more than ONE transmitter to the same operating frequency.)

Testing Receiver Range

Wearing your receiver and earphones, walk around the stage area and listen for audio quality. Depending on room size, obstructions, amount of reflective metal surfaces, and other conditions that may affect RF transmission, it is normal that the audio may disappear or "drop out" in certain locations. Such zones, otherwise known as "null spots" are very small and fixed in location if you are within 100 feet of the transmitter and will become larger as you approach the ultimate range of your system in that location (up to 500 feet. Depending on site conditions). Generally, it is possible to eliminate such "null spots" by moving your PEM-1000T transmitter as little as 12-18 inches in any direction. If that is not convenient (e.g., because the PEM-1000T is rackmounted), you can also use an optional remote antenna. Contact the NADY SYSTEMS Service Department for information about remote antennas for the PEM-1000T. After you move the transmitter or relocate a remote antenna, range walk the stage and other areas you will use in your performance to again check for consistent reception. You are now ready to use the PEM-1000 system for wireless personal in-ear monitoring.

(Note: Due to the strong transmission power of the PEM-1000T, you may experience compromised audio or static if the PEM-1000R is too close to the antenna of the PEM-1000T transmitter. Always operate the receiver at least 6 ft (2 m) away from the transmitter antenna.)

Cautions During Operation

1. When this in-ear wireless monitoring system is used together with a wireless microphone system, make sure they are not on close frequencies to avoid their possible interference with each other.
2. If using a coaxial cable to connect the transmitter to a remote antenna, note that the coaxial cable must be 50 and less than 5 meters long for optimum operating range.
3. Maintain line-of sight-operation at all times, when possible, for best performance and range.
4. For best performance use only the supplied power adapter for the transmitter.
5. If using earphone other than those supplied, make sure they have a sensitivity of at least 110dB/mW. Note that the receiver's battery life diminishes as earphone volume is increased or earphones have low sensitivity, which requires more power to drive to a desired volume.
6. Always remove batteries from receiver if not using them for a long time as leaking batteries can damage the unit.

Specifications

Operating Frequency Range	Band 1 - 673 MHz to 685.375 MHz / Band 2 - 583 MHz to 607.750 MHz
Modulation	Mono or stereo (MPX with pilot tone), FM: F3E +/- 25 KHz, nominal
Audio Frequency Response	50 ~ 15,000 Hz (-3dB)
T. H. D.	< 1%
Signal-to-Noise Ratio	> 80 dB, with proprietary companding noise reduction
Operating Range	Up to 500 feet typical (depending on site conditions)

PEM-1000T Transmitter

RF Output Power	100 mW (Hi), 10 mW (Lo), country dependent
Spurious Emission	> -55 dBc
Frequency Stability	+/- 100 PPM
Headphones Out Power	50 mW max. @ 16 ~ 32
Input impedance	750 (L/R Audio Line Inputs)
Nominal Input Level	0 dBm
Max. Input Levels	+4dB/+10dB Selectable
Controls	Power ON/OFF, Menu buttons; headphones monitor volume control
Connectors	¼" stereo headphones monitor out, Combo ¼" and XLR female type in, and ¼" TS unbalanced loop out jacks, 1/12" barrel-type DC input jack; BNC antenna socket
Indicators	Power ON LED; Channel LCD and 5-segment L-R audio LED input displays
Antenna	¼ wave rigid detachable, BNC mount
Power Requirement	External 12V/1000mA (110V-240V auto selection)
Dimension	8.27" x 9.1" x 1.75" (210 x 231 x 45mm)
Weight	2.98 lbs (1.35 Kg)

PEM-1000R Receiver

Maximum Audio Output Level	80 mW max, 5mW (Limiter ON) @ 16 ~ 32
RF Sensitivity	2.5uV (-100 dB/12 dB SINAD)
Squelch Threshold	< -90 dB
Spurious Rejection	> 55 dBc
Audio Output Connector	1/8" Stereo (Tip=Left, Ring=Right, Sleeve=ground)
Controls	Volume/ON/OFF, IR window, STEREO/MONO, Limiter ON/OFF switches, LOCK, SYNC, SCAN buttons and MUTE button
Indicators	Low Battery LCD (5 Bars), Signal ON (RED LED)
Power Requirements	1.5Vx2 alkaline batteries
Current Drain	130 mA~260mA
Battery Life	Up to 8 hours, volume dependent
Antenna	External Flexible
Dimensions	4.5" x 0.9" x 2.6" (115 x 23 x 66 mm)
Weight	2.85 oz (80 Kg)

OPTIONAL ACCESSORIES

RKT-11 Single transmitter rackmount kit. Includes front antenna mount, jack and connecting cable.

RKT-21 Dual (side-by-side) transmitters rackmount kit

Operating Frequency Range

Band 1 - 673.00 MHz - 685.375 MHz

CHS	01	11	21	31	41	51	61	71	81	91
1	673.000	674.250	675.500	676.750	678.000	679.250	680.500	681.750	683.000	684.250
2	673.125	674.375	675.625	676.875	678.125	679.375	680.625	681.875	683.125	684.375
3	673.250	674.500	675.750	677.000	678.250	679.500	680.750	682.000	683.250	684.500
4	673.375	674.625	675.875	677.125	678.375	679.625	680.875	682.125	683.375	684.625
5	673.500	674.750	676.000	677.250	678.500	679.750	681.000	682.250	683.500	684.750
6	673.625	674.875	676.125	677.375	678.625	679.875	681.125	682.375	683.625	684.875
7	673.750	675.000	676.250	677.500	678.750	680.000	681.250	682.500	683.750	685.000
8	673.875	675.125	676.375	677.625	678.875	680.125	681.375	682.625	683.875	685.125
9	674.000	675.250	676.500	677.750	679.000	680.250	681.500	682.750	684.000	685.250
10	674.125	675.375	676.625	677.875	679.125	680.375	681.625	682.875	684.125	685.375

Band 2 - 583.00 MHz - 607.75 MHz

CHS	01	11	21	31	41	51	61	71	81	91
1	583.000	585.500	588.000	590.500	593.000	595.500	598.000	600.500	603.000	605.500
2	583.250	585.750	588.250	590.750	593.250	595.750	598.250	600.750	603.250	605.750
3	583.500	586.000	588.500	591.000	593.500	596.000	598.500	601.000	603.500	606.000
4	583.750	586.250	588.750	591.250	593.750	596.250	598.750	601.250	603.750	606.250
5	584.000	586.500	589.000	591.500	594.000	596.500	599.000	601.500	604.000	606.500
6	584.250	586.750	589.250	591.750	594.250	596.750	599.250	601.750	604.250	606.750
7	584.500	587.000	589.500	592.000	594.500	597.000	599.500	602.000	604.500	607.000
8	584.750	587.250	589.750	592.250	594.750	597.250	599.750	602.250	604.750	607.250
9	585.000	587.500	590.000	592.500	595.000	597.500	600.000	602.500	605.000	607.500
10	585.250	587.750	590.250	592.750	595.250	597.750	600.250	602.750	605.250	607.750

Consumer Alert

Most users do not need a license to operate this wireless in-ear monitor system. Nevertheless, operating this system without a license is subject to certain restrictions: the system may not cause harmful interference; it must operate at a low power level (not in excess of 50mW); and it has no protection from interference received from any other device. Purchasers should also be aware that the FCC is currently evaluating use of wireless microphone systems, and these rules are subject to change.

For more information, call the FCC at 1-888-CALL-FCC (TTY: 1-888-TELL-FCC) or visit

www.fcc.gov/cgb/consumerfacts/wirelessmic_factsheet.html.

One Year Limited Warranty

Nady Systems, Inc. warrants to the original consumer purchaser that the unit is free from any defects in material or workmanship for a period of one year from the date of original retail purchase. If any such defect is discovered within the warranty period, Nady Systems, Inc. will repair or replace the unit free of charge, subject to verification of the defect or malfunction upon return to Nady Systems. Please do not return your Nady product to the store where it was purchased as Nady Systems handles your warranty service directly. Communication with our Service Department is the most efficient means of servicing your unit and we are dedicated to keeping you a satisfied customer.

To the extent permitted by law, any applicable implied warranties, including warranties of merchantability and fitness are hereby limited to one year from the date of purchase. Consequential or incidental damages resulting from a breach of any applicable express or implied warranties are hereby excluded. This warranty is in lieu of all other agreements and warranties, general or special, express or implied and no representative or person including a Nady dealer, agent, or employee is authorized to assume for us any other liability in connection with the sale or use of this Nady Systems' product.

Whereas some states do not allow limitations on how long implied warranties last, and do not allow exclusion of incidental or consequential damages, the above limitations and exclusions may not apply to you. This warranty gives you specific legal rights and you may also have other rights which may vary from state to state.

This warranty is subject to the following conditions:

1) This system must have been purchased from an authorized Nady dealer and all warranty service must be performed by Nady's service department. Any service not performed by Nady will automatically void this warranty.

2) Items not covered: physical damage resulting from improper handling of the unit in transit from the factory by the shipper (Nady Systems is not responsible for such damage and all such claims must be made against the shipping company by the consignee); defects caused by normal wear of the product (expendable parts are typically connectors, cables, potentiometers, switches and similar components); damage or defects caused by abuse, neglect, accident, failure to connect or operate the unit in any way that does not comply with applicable technical or safety regulations, or improper repair, excessive heat or humidity, alteration or unreasonable use of the unit, causing cracks, broken cases/housings or parts; damage caused by leaking batteries; finish or appearance items; items damaged in shipment en route to Nady Systems, Inc. for repair. The warranty is null and void if any Nady serial number has been removed or defaced.

Service

(U.S.) Should your Nady PEM-1000 Wireless Personal In-Ear Monitor System require service, please contact the Nady Service Department via telephone at (510) 652-2411 or e-mail to service@nadywireless.com for a Return Authorization (R/A) Number and a service quote (if out of warranty). Make sure the R/A Number is clearly marked on the outside of the package that you send in and enclose a cashier's check or money order (if not prepaid with a credit card). Ship the unit prepaid to: Nady Systems, Inc., Service Department, 6701 Shellmound Street, Emeryville, CA 94608. Include a brief description of the problem you are experiencing.

(INTERNATIONAL) For service, please contact the Nady distributor in your country through the dealer from whom you purchased this product.

The warranty card enclosed with this system contains additional valuable warranty and service information. Keep it in a safe place for possible future reference. Do not attempt to service this unit yourself as it will void the warranty.

DO NOT ATTEMPT TO SERVICE THIS UNIT YOURSELF AS IT CAN BE DANGEROUS AND ALSO WILL VOID THE WARRANTY



6701 Shellmound Street | Emeryville, CA USA 94608
T 510.652.2411 | **F** 510.652.5075 | www.nady.com