

Phottix Mitros TTL Flash for Canon

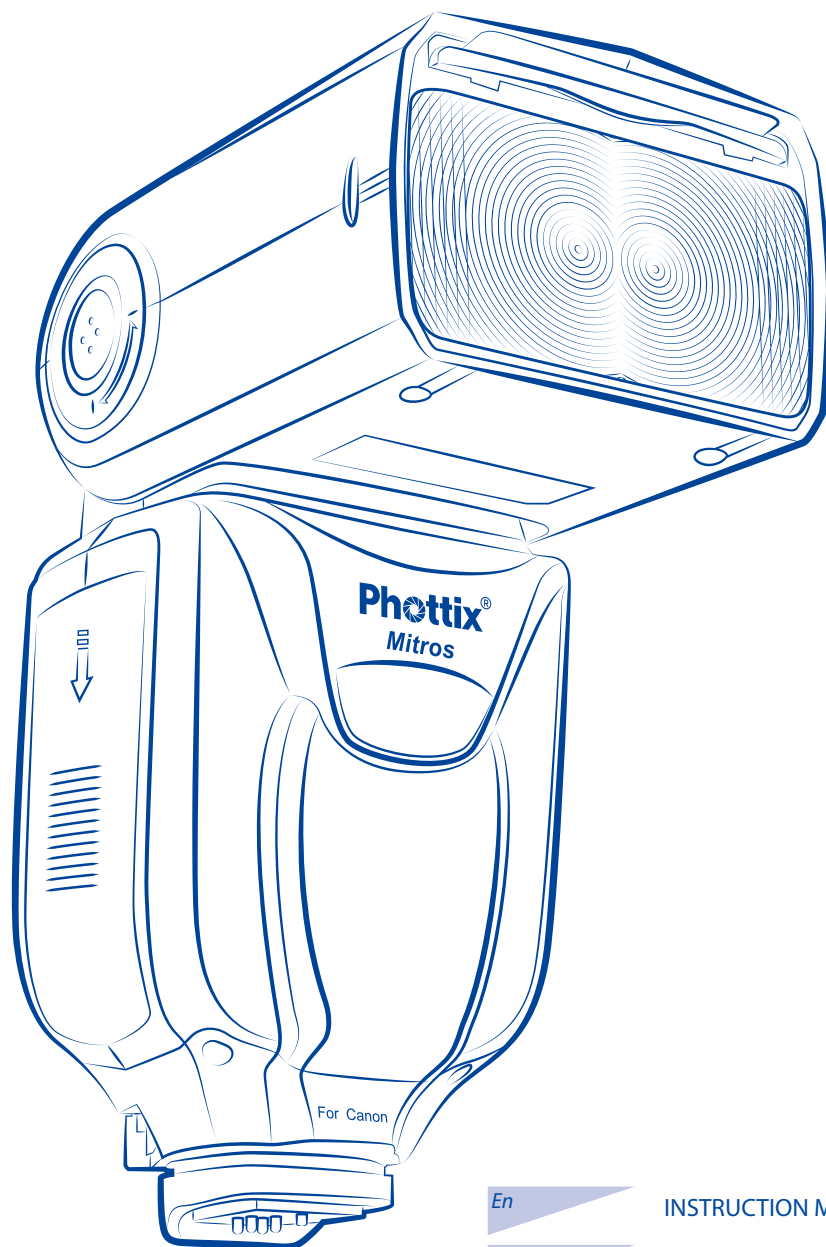

En	INSTRUCTION MANUAL
De	BENUTZERHANDBUCH
Fr	MANUEL D'UTILISATION
Es	MANUAL DE INSTRUCCIONES
Pl	INSTRUKCJA OBSŁUGI
It	ISTRUZIONI D'USO
Ru	РУКОВОДСТВО ПОЛЬЗОВАТЕЛЯ
Cn ^{Simp}	说明书

Phottix Mitros TTL Flash for Canon

Note: To start immediately using this flash please refer to the quick-start guide. For advanced features please read this manual and be familiar with your camera manual and operations.

The Phottix Mitros TTL Flash for Canon is designed to work with Canon DSLR cameras and features E-TTL I/II, Manual, Multi modes as well as Wireless Master/Slave triggering.

Warnings

1. Use your flash safely. Do not fire the flash into the eyes of people or animals at short distances – damage and/or blindness can occur.
2. Be careful using the flash in or around cars, buses, motorcycles or other moving vehicles as accidents can result.
3. Never use the flash near combustible gases (gasoline, solvents, etc.).
4. Do not expose the flash or batteries to dripping/splashing water, or high humidity.
5. Do not leave the flash or batteries in a hot location (direct sunlight, in a closed car, etc.).
6. Remove batteries from the flash when not being used for an extended period of time.
7. Change the batteries when required. Use undamaged batteries in good condition. Do not mix battery types or new and used batteries.
8. Do not put opaque objects in front of the flash lens when firing the flash. The energy emitted by the flash may cause objects to burn, or cause damage to the flash tube or fresnel lens.
9. Use caution in touching the flash head after use. It may be hot and can cause burns.
10. The flash contains high voltage electronic parts. Do not disassemble or attempt to repair the flash. Never touch the flash's internal components.
11. Do not touch the External Power Port contacts with any metal objects – this can cause electric shock and serious injury.

Table of Contents

Parts and Functions	2
Modes	7
Wireless Triggering.....	9
Custom Functions.....	11
Technical Specs.....	12

Parts

Back / Left Side

1. LCD Display
2. Mode Button
3. Test Button
4. Power Switch
5. Ready Light
6. Arrow Adjustment Buttons (see below)
7. Set Button
8. Locking Lever
9. 3.5mm Sync Port
10. USB Port
11. External Power Port

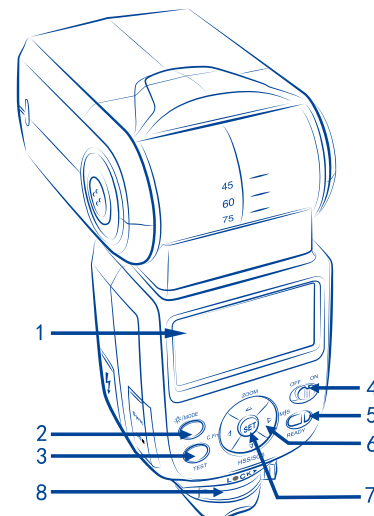
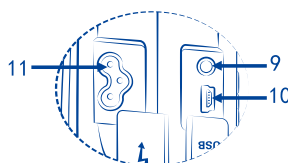

Arrow Adjustment Buttons

1. Up Arrow / Zoom Adjustment Mode Button
2. Right Arrow / Wireless Flash Mode Button
3. Down Arrow / HSS / SCS Button
4. Left Button / Custom Functions Button

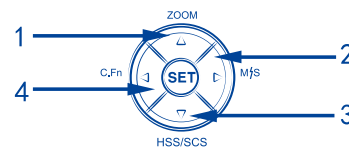

Front / Right Side

1. Bounce Card
2. Wide Angle Diffuser
3. Flash Head
4. Wireless Signal Receiver Area
5. AF Assist Light
6. Hot Shoe
7. Battery Compartment

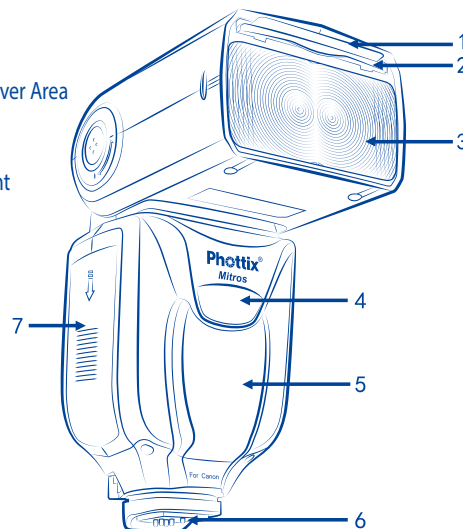

Please note:

These instruction assume:

1. Both the flash and camera are switched on.
2. The flash and camera are set to the same settings as this manual.
3. Camera menu and flash custom functions menu are set to default values.
4. The flash is being used with a compatible Canon DSLR.

Installing batteries

1. Press the battery cover in while pushing it towards the bottom of the flash. The battery cover will open and raise.
2. Insert AA batteries as shown by the diagram inside the battery compartment.
3. Lower the battery cover and push back towards the top of the flash, locking it in place.

Please note:

- Please use four standard high-quality batteries of the same brand. Make sure all batteries are at similar powers levels.
- Batteries can get hot when the flash is being used. Use caution when changing batteries.
- If you do not use the flash for an extended period of time, store with batteries removed.

Attaching the flash to a camera

Turn off both the camera and flash

1. Align the flash hot shoe with the camera hot shoe.
2. Slide the flash into the camera hot shoe until fully inserted.
3. Lock the flash in position by pushing the locking lever to the right until the lock engages with a click.
4. To Unlock, press the locking release button on the locking lever and slide to the left.

Turning the Flash On / Off

1. To power on the flash move the power switch to the on position.
2. To power off the flash move the power switch to the off position.

Battery Level Indicator

The Battery Level Indicator on the LCD (see below) will display an approximate indication of how much power remains in the batteries in the flash. Use this as a rough guide as to when a battery change is needed. If flash recycling time has become very long (30 seconds) change the batteries.

Raising and Rotating the Flash Head

1. The flash head will elevate from -7 to 90 degrees with stops at -7, 0, 45, 60, 75 and 90 degrees. Gently raise or lower the flash head into the required position.
2. The flash head will rotate 180 degrees in either direction with stops at 60, 75, 90, 120, 150 and 180 degrees. Gently rotate the flash head into the required position.
3. When the flash head is raised or rotated from the 0 degree standard forward position the flash zoom will set itself to 50mm. "- -" will be displayed on the LCD. Flash zoom when the head is raised or rotated can be changed in MZoom mode (see below).
4. At -7 degrees the flash zoom will act the same as 0 degree – it will not change any settings.

Using the Bounce Card or Wide Angle Diffuser

The Phottix Mitros Flash comes equipped with a white bounce card and wide angle diffuser panel in the flash head.

1. The wide angle diffuser panel will cause the flash to spread light to a 14mm equivalent.
2. The white bounce card can be used when the flash head is in a raised position to bounce light forward to assist with catch lights in a subject's eyes.

To use:

1. Gently pull the diffuser panel and bounce card from the flash head using the ridge on the bottom of the diffuser panel.
2. If using the diffuser panel it will drop into position over the flash head. Gently push the bounce card back into the flash head if not needed.
3. If using the bounce card only gently push the diffuser panel back into the flash head.

Using the Flash Head Diffuser

The Phottix Mitros TTL Flash comes with an attachable diffuser that can be added to the front of the flash head when needed. It is good for softening light, reducing hot spots and shadows and better coverage for macro photography.

To use:

1. Align the diffuser with the flash head, with the "UP" mark on the diffuser facing up.
2. Snap one side of the diffuser mount into the corresponding flash head mount.
3. Repeat step 2 on the other side of the diffuser.

Overheating Protection

The Phottix Mitros contains an overheating protection circuit that will slow flash recycle time to avoid overheating-related damage. Approximately 20 full-power flashes in a short amount of time will trigger this protection. A [Hot!] Icon will appear when the overheating protection circuit is in operation.

To avoid further overheating or possible damage the flash will increase the recycling time to assist in lowering the flash temperature. Wait 10 minutes before using the flash.

If the flash continues to be used after the [Hot!] Icon appears and the flash does not cool down a [Stop] icon will appear on the LCD. Cease using the flash and wait 10 minutes for it to cool down.

Sync and USB Ports

1. The 3.5mm Sync Port can be used with a 3.5mm sync cable to trigger the flash – from a flash trigger or camera. This port is input only – flash signals are not output from this port.
2. The USB port is used for firmware upgrades. Firmware announcements and instructions will be made available on Phottix websites.

Status LED

Left LED: Flash-ready indicator. In Quick Flash Mode, the LED will flash green when the flash has the minimum recycle charge. It will flash red when fully charged.

Right LED: Flash exposure confirmation lamp. If a standard flash exposure is obtained, the flash exposure confirmation lamp will light blue for approximately 3 seconds. If the flash exposure confirmation lamp doesn't light, move closer to the subject or increase the camera ISO setting.

External Battery Port

The External Battery Port is a proprietary Phottix design for use with Phottix flash cables. The external port is compatible with the Canon CP-E4 compact battery pack or compatible models when the included adapter is used.

Please note:

- Batteries must be used in the flash even when an external battery pack is used.
- Never use non Canon-compatible battery packs.

The LCD Display

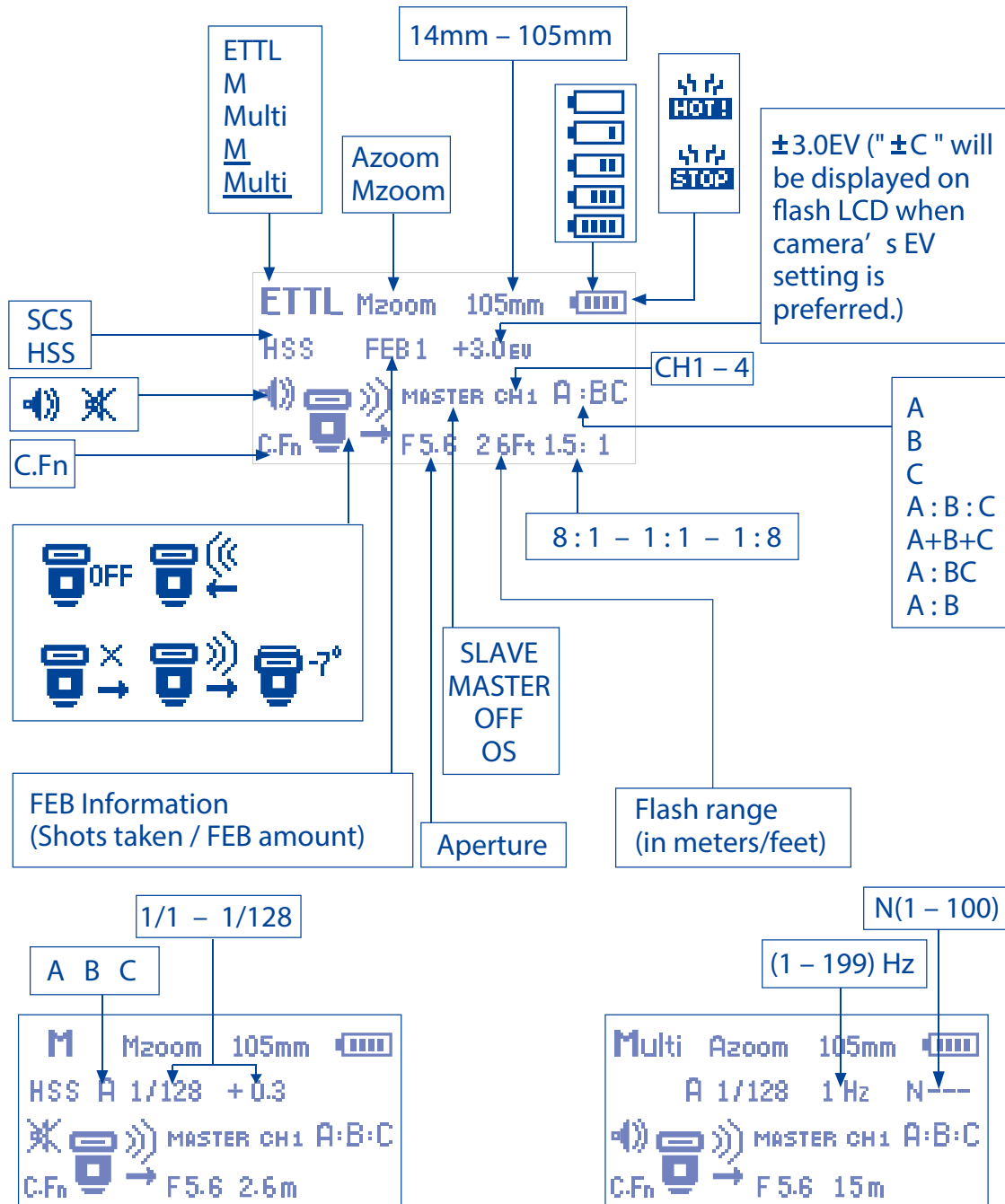

The LCD display on the Phottix Mitros flash contains important information regarding flash settings and functions.

Top Line:

1. Flash Mode: Indicates the set mode of the flash - ETTL, Manual, Multi, M (slave mode), Multi (slave mode)
2. Zoom: Indicates auto or manual flash head zoom and distance
3. Battery Level Indicator, Hot!, Stop

Second Line:

- High Speed Sync (HSS) / Second Curtain Sync (SCS) icon
FEB, Group, Power Level, EV, Multi Mode indicators (Frequency and Flash Count)

In ETTL mode: HSS/SCS, FEB, EV

In M mode: HSS/SCS, Group, Power Level

In Multi mode: Group, Power Level, Frequency, Flash Count

Third Line:

Beep Signal Icon, "-7°" icon, Master / Slave Triggering Area - displays channel, master/slave mode, group information

Fourth Line:

Flash and Exposure information: C.Fn icon, Aperture (f stop), flash range and flash ratio





Auto-Save Functions

The Phottix Mitros will remember flash settings. Mode, power levels, etc. will be retained in the flash if it is turned off and then back on.

Setting Flash Zoom

The Phottix Mitros Flash has two flash head zoom modes – Auto (Azoom) and Manual (Mzoom). Auto zoom will dynamically change flash head zoom as a camera's zoom lens is changed to provide optimum lighting. Manual zoom allow the user to set the zoom of the flash head.

To set:

1. Press the  button.
2. The Zoom area on the LCD will be highlighted and flash.
3. Press the  or  buttons to set the flash head zoom to Azoom or the desired Mzoom manual level.
4. Press the  button when the zoom is properly set.



Please Note:

1. When in Azoom and the flash head is raised or rotated from the 0 degree standard forward position - the flash zoom will set itself to 50mm. "- -" will be displayed on the LCD. The flash zoom will not change if the head is lowered to -7 degrees.
2. Azoom will work ONLY when the flash head is set to either 0 or -7 degrees.
3. When in Mzoom and the flash head is raised or rotated from the 0 degree standard forward position - the flash zoom will not be changed from the previous setting.
4. Flash Zoom can be adjusted when the head is raised or rotated by switching to Mzoom mode and making desired adjustments.

Setting High Speed Sync or Second Curtain Sync

The Phottix Mitros flash has both High Speed Sync and Second Curtain Sync functions. See further details under High Speed Sync and Second Curtain Sync later in this manual.

To set:

1. Press the  button.
2. The  button will cycle between HSS, SCS and turning both off.

Please note:

-HSS and SCS are available in E TTL and Manual modes, but not in Multi mode.

Test Button

Pressing the test button will trigger the flash. This can be used for metering (in manual mode only). In Wireless Master Mode pressing the test button will fire slave flashes on the same channel being controlled by the Master flash. Test button output levels can be configured (see C.Fn-07 below).

Auto-Idle Functions

To save battery power the Phottix Mitros TTL Flash is equipped with Idle and Auto Off modes.

1. In Non-Wireless Slave Modes: The flash will go into Auto Idle mode after 90 sec. if no buttons have been pressed or it has not been fired. The flash LCD will go blank. Half-pressing the camera shutter button or pressing the test button on the flash will wake up the Phottix Mitros.

2. In Wireless Slave Mode, the flash will go to Slave Idle Mode after 60 minutes if no buttons have been pressed or it has not been fired, "IDLE" will be displayed on the flash LCD. Full-pressing the camera shutter button or pressing the Master flash test button will wake up flashes in idle mode. Slave Idle Timer can be changed from 60 minutes to 10 minutes (see C.Fn-10 below). The flash will go into Slave Auto Off Mode after 8 hours if no buttons have been pressed or it has not been fired after "IDLE" is displayed on the flash LCD. Pressing the test button on the flash will wake it up. Slave Auto Off can be changed from after 8 hours to after 1 hour (see C.Fn-11 below).

Modeling Flash

1. Pressing the camera depth-of-field preview button (if available) will fire the flash continuously for 1 second. This Modeling Flash is useful in seeing lighting effects and balance on the subject.
2. Modeling Flash is available in all modes, E TTL, Multi and Manual.
3. Modeling Flash can be used in both normal and wireless shooting and can be set (see C.Fn-02 below).

Please note:

1. Overheating and damage can result from excessive use of the Modeling Flash. Do not use more than 20 times in succession.
2. When overheating the flash will automatically increase charging time until the flash temperature has decreased.

Autofocus (AF) Assist Light

1. In low light/contrast situations the Phottix Mitros' built-in Auto Focus Assist Light will illuminate to assist with AF. The AF Assist Light on the front of the flash will project a focusing target on the subject.
2. AF Assist Light functions can be set to on or off (see C.Fn-08 below).

Adjustments

The Phottix Mitros will adjust levels in 1/3 stop increments. Some cameras have custom functions to change stop adjustments from 1/3 to 1/2 stop increments for FEB and FEC. If camera custom functions are changed the Phottix Mitros will automatically adjust levels in 1/2 stops.

Flash Modes

The Phottix Mitros has three flash modes: E TTL, Manual (M) and Multi (Stroboscopic).

To change modes:

1. Press the  button.
2. The flash modes will cycle through E TTL, Manual (M) and Multi modes.
3. The current mode will be displayed in the top left corner of the LCD.

E TTL Mode



In E TTL Mode the flash and camera will work together to calculate the correct exposure for recorded images. When the shutter button is fully pressed the flash will fire a pre-flash that the camera will use to calculate exposure and flash power the instant before the photo is taken.

Flash Exposure Compensation - FEC

The Phottix Mitros Flash offers Flash Exposure Compensation (FEC) functions and adjustments from -3 to +3 in 1/3rd stops. This is useful in situations where fine-tuning of the TTL system is needed based on the environment.

To set FEC:

1. Press the  button to enter FEC Adjustment Mode.
2. Press the  or  buttons to adjust FEC up or down.
3. Press the  button to exit FEC Adjustment Mode.

Please note:





- Some cameras have custom functions to change stop adjustments from 1/3 to 1/2 stop increments for FEB and FEC. If camera custom functions are changed the Phottix Mitros will adjust levels in 1/2 stop increments.

Flash Exposure Bracketing - FEB

Flash Exposure Bracketing (FEB) can be used to automatically change flash power over a series of photos. The camera will record three images with different exposures – one exposed as per camera calculations, one over-exposed and another under-exposed. Over and under exposure levels can be set by the user. FEB is useful in run-and-gun situations as well as when shooting scenes with different lighting conditions to help ensure a properly exposed photo. It can also be used for HDR photography.

Some cameras have flash exposure storage function, see your camera user manual for more details.

To Set FEB:

1. Press the  button.
2. Press the  button. "FEB 0" will be displayed and highlighted on the LCD.
3. Press the  and  buttons to adjust the exposure bracketing amount.
4. Press the  button to confirm the setting.

Please note:

- By default: FEB will be cancelled after three photos are taken. FEB can be set in the Custom Functions screen (see C.Fn-03 below).
- FEB shooting sequence can be changed (see C.Fn-04 below).
- FEB can be used with FEC and FEL (see below).
- For best results set the camera drive mode to "single" and ensure the flash is fully recharged before taking the second and third photos.
- Some cameras have custom functions to change stop adjustments from 1/3 to 1/2 stop increments for FEB and FEC. If camera custom functions are changed the Phottix Mitros will adjust levels in 1/2 stop increments.

Flash Exposure Lock - FEL

Flash Exposure Lock (FEL) can be used to lock the flash exposure before a photo is taken. This is useful when manual spot metering is being used in a scene with different lighting conditions.

While in E TTL mode, press the camera's FEL button (the "✳" button) to use this function. See your camera user manual for more information on FEL functions and usage.

Pressing the FEL Button will cause the flash to fire a pre-flash that will be used to calculate flash power during the exposure. This will be retained in the camera memory. The FEL icon will be displayed in the camera viewfinder.

Each time the FEL button is pressed a pre-flash will fire and a new exposure calculated. When the shutter button is fully pressed the flash will fire at the locked exposure.

Please note:

- If the subject is too far away underexposure will result, the "FEL" icon will blink for approximately 0.5 sec. in the camera viewfinder.
- If the subject is too small in the viewfinder, FEL may not be effective.

High Speed Sync – HSS

In HSS mode, the camera/flash maximum sync speed can reach the camera's maximum shutter speed. This is useful when using aperture priority mode or to limit ambient light. HSS may vary with different camera models - see your camera user manual for details.

To use HSS mode:

1. Press the  button.
2. The HSS icon will be displayed on the flash LCD.
3. Set shutter speeds higher than the camera's flash sync speed and take photos.

To exit HSS mode:

1. Press the  button twice.
2. It will cycle from HSS to SCS and back to regular FCS mode.



Please note:

- Check that the HSS icon is displayed in the viewfinder.
- HSS drastically reduces flash power, battery power and range.

Second Curtain Sync – SCS

The Phottix Mitros Second Curtain Sync function makes the flash fire at the end of an exposure, not the beginning. This can be useful with slow shutter speeds for capturing special effect.

To use:

1. Press the  button twice. This will cycle from FCS to HSS and then the SCS mode.
2. To cancel: Press the  button once. This will return to standard FCS mode.







Please note:

SCS functions will not work in Wireless or Multi modes.

Manual (M) Mode

In Manual Mode the flash will fire at the power level you set. The Phottix Mitros TTL Flash can be adjusted from 1/1 (full power) to 1/128 – 8 stops of adjustments in 1/3rd stop increments. Aperture, shutter speed and ISO on the camera needs to be manually adjusted. For best results use M-Manual mode on the camera.

To use:

1. Press the  button until M is displayed on the flash LCD.
2. Press the  button to enter the power adjustment screen. The power level will flash and be highlighted.
3. Press the  or  buttons to adjust the flash power.
4. Press the  button to exit the power adjustment screen.
5. When the flash ready light is illuminated red the flash is fully charged and ready to fire.
6. Pressing the  button will fire the flash at the manual power level you set. This is useful when taking meter readings.

Please note:







- Half pressing the shutter button will display the effective manual flash power range on the Flash LCD.

Multi: Stroboscopic Mode

With Multi Stroboscopic mode a series of rapid flashes will be fired. The flash count, frequency and power of these flashes can be programmed on the Phottix Mitros. Multi mode is useful for capturing multiple images of a moving subject in the same photo and other special effects.

The frequency of the effect (in Hz. - number of flashes per second), the total number of flashes and output levels can be set.

To use:

1. Press the  button until Multi is displayed on the flash LCD.
2. Press the  button to adjust Multi settings. Displayed (from left to right on the LCD) Power, Frequency (HZ) and Flash Count. Power is highlighted and flashing upon entering the adjustment screen.
3. Press the  and  buttons to change between Power, Frequency (HZ) and Flash count.
4. Press the  and  buttons while the setting is highlighted to adjust Power, Frequency (HZ) and Flash count to the desired levels.

5. Press the  button to exit the adjustment screen.

Please note:

1. Overheating and damage can result from excessive use of the Multi Stroboscopic Mode. Do not use more than 20 times in succession.
2. When overheated the flash will automatically increase charging time until the flash temperature has decreased.

Stroboscopic Mode and Shutter Speeds

To determine the proper camera shutter speed to be used with various Stroboscopic Mode variables, use the following formula:

Number of flashes / Frequency = Shutter Speed

Example: 5x (number of flashes) / 10 Hz (Frequency) = .5 second shutter speed.

This is a rough guideline: You may need to increase or decrease the shutter speed to get the desired result.

Multi Stroboscopic Mode Output Chart

Flash Output \ Hz	1	2	3	4	5	6-7	8-9	10	11	12-14	15-19	20-50	60-199
1/4	7	6	5	4	4	3	3	2	2	2	2	2	2
1/8	14	14	12	10	8	6	5	4	4	4	4	4	4
1/16	30	30	30	20	20	20	10	8	8	8	8	8	8
1/32	60	60	60	50	50	40	30	20	20	20	18	16	12
1/64	90	90	90	80	80	70	60	50	40	40	35	30	20
1/128	100	100	100	100	100	90	80	70	70	60	50	40	40

If the number of flashes is displayed as "N---", the maximum number of flashes will be as shown by the table below regardless of the firing frequency.

Flash Output	1/4	1/8	1/16	1/32	1/64	1/128
Flash count	2	4	8	12	20	40

Wireless Triggering Mode

The Phottix Mitros TTL Flash is equipped with wireless triggering. Using pulses of light, a flash on the camera adjusts and fires remote flashes.

The Phottix Mitros can also be triggered as an Optical Slave (OS). In OS mode other nearby fired flashes will trigger the Mitros in manual mode only.

A flash set in Master mode must be attached to the camera (or the camera pop-up flash used, if compatible). Remote flashes must be set to slave mode.



Wireless triggering is achieved by pulses of light fired by the Master flash. All flashes must be in line of sight. The Wireless Signal Receiver Area must be able to "see" signals from the Master flash. This system may not perform well outdoors or in brightly lit areas.

For increased performance and power control consider using the Phottix Odin TTL Flash Trigger with your Phottix Mitros flash. The Phottix Odin controls and fires TTL flashes via radio signals, not pulses of light, and is less limited in all environments.

Optical Slave (OS) Mode

In Optical Slave (OS) Mode the Phottix Mitros will fire when it optically "sees" another nearby flash fire. The Mitros will fire in manual mode at the power levels it was set to.

To Set OS Mode:

1. Press and hold the  button for 2 seconds to enter wireless mode.
2. Press  button to cycle to OS mode.
3. Press the  button to confirm and exit the screen.
4. The flash will change to Manual-M mode.
5. Set the desired power level.





Please note:

- Do not place any obstacles between the master unit and slave unit(s). Obstacles can block signal transmissions.
- Ensure the slave flash's Wireless Signal Receiver Area faces toward the triggering flash.
- TTL pre-flashes will set off a flash set to OS mode. The flash will fire before the exposure. Do not mix OS mode with other flashes using TTL.
- Unlike other Wireless Mode, Optical Slave (OS) does not use channels. A flash set in OS mode will fire when it sees any flash trigger.

Wireless Settings

Flashes must be set to Master or Slave mode. A Master flash is needed on the camera to control remote (slave) flashes. The same transmission channel needs to be set on both Master and Slave flashes. Groups need to be set for Slave flashes, Group Ratio functions needs to be set for Master flashes.

To set Master Mode:







1. Press and hold the  button for 2 seconds to enter wireless mode.
2. Pressing the  and  buttons will cycle between Master with flash, Master without flash, Slave, OS and Off modes.
3. Select Master with flash or Master without flash.
4. Pressing  button will change the highlighted selection from Master to Channel and Ratio.

5. Select the transmission channel.
6. Select the Ratio mode (see below).
7. Press the  button to confirm and exit the screen.

Master with Flash mode: The Master flash on the camera will fire when a photo is taken.

Master without Flash mode: The Master flash on the camera will not fire when a photo is taken. The flash will emit a short burst of light to communicate with slave flashes but this light will not be part of the exposure.

To set Slave Mode:

1. Press and hold the  button for 2 seconds to enter wireless mode.
2. Pressing the  and  buttons will cycle between Master with Flash, Master without Flash, Slave, OS and Off modes.
3. Select Slave.
4. Pressing the  button to change the highlighted selection from Slave to Channel and Group.
5. Select the Transmission Channel.
6. Select the group: A, B or C.
7. Press the  button to confirm and exit the screen.
8. When Slave flashes are ready to shoot the AF Assist light on the front of the flash will blink once every 1 second.
9. To set Multi or M modes for the Slave – press and hold the  button for approximately 2 sec.
10. Set Power Levels or Multi Strobe Frequency / Flash Count using the arrow buttons.

Please note:

- Make sure the Master and Slave flashes are set to the same transmission channel (1-4).
- Do not place any obstacles between the master unit and slave unit(s). Obstacles can block signal transmissions.
- When using wireless bounce flash, please ensure the slave flash Wireless Signal Receiver Area faces toward the Master flash.
- When using only one flash set Wireless Mode to "Off".

Transmission channels

The Phottix Mitros Wireless system has four transmission channels: 1, 2, 3 and 4. Signals from the Master flash are sent to Slave flashes on these channels. If Master and Slave flashes are set to different channels the Slave flashes will not fire.

Using Wireless Triggering

With a flash in Master mode on the camera and remote flashes in Slave mode, pressing the shutter button will fire the Master flash (if set to Master with flash) and flashes set to Slave mode within the range of the Master flash. The camera and flash will meter the scene and fire flashes in TTL mode to properly expose the scene.

Ratio Modes







Slave flashes can be controlled by the master flash in different ratio modes. Available modes are:

ETTL Modes

A+B+C All three groups fire at an average of the total calculated output.



A:BC Groups A and B can be set by Flash Ratio (see below). Group C is independent with its flash output level assigned by the camera.

The EV compensation of Groups A and B can be adjusted.

1. Press the  button after exiting the Flash Ratio Setting Screen.
2. Press the  or  buttons to adjust up or down EV for Groups A and B.
3. The EV compensation for Group C can also be adjusted.
4. Pressing the  button after setting the flash ratio will move the highlighted selection to EV adjustment for Group C.
5. Press the  or  buttons to adjust the EV for Group C.











A:B Groups A and B can be set by Flash Ratio (see below). Group C is not adjustable and does not fire.

The EV compensation of Groups A and B can be adjusted.

1. Press the  button after exiting the Flash Ratio Setting Screen.
2. Press the  or  buttons to adjust up or down EV for Groups A and B.

Setting and Adjusting Ratio Modes

ETTL Modes

1. Press and hold the  button for 2 seconds to enter wireless mode.
2. Pressing the  and  buttons will cycle between Master with flash, Master without flash, Slave, OS and Off modes.
3. Select Master with flash or Master without flash.
4. Pressing  button will change the highlighted selection from Master to Channel and Ratio.
5. Select the transmission channel.
6. Select the Ratio mode. Pressing the  and  buttons will cycle between A+B+C, A:B and A:BC modes.
7. When A:B or A:BC are highlighted pressing the  button will highlight the ratio adjustment selection below the ratio.
8. Pressing the  button will change the ratio from 1:1 to 1:8 in steps of 1:1.5, 1:2, 1:3, 1:4, 1:6, 1:8.
9. Pressing the  button will change the ratio from 1:1 to 1.5:1, 2:1, 3:1, 4:1, 6:1, 8:1.
10. Press the  button to confirm and exit the screen.



Manual Modes

A+B+C In manual mode all three groups fire at the same output level. This power level can be set.

A:BC The output level of each group is individually adjusted by the user (see below). Each group is independent, one not affecting the other.

A:B Groups A and B power level can be set individually by the user (see below). Group C is not adjustable and does not fire.

Setting and Adjusting Manual Modes

1. Press the  button to change the flash into Manual (M) Mode.
2. Press and hold the  button for 2 seconds to enter wireless mode.

3. Pressing the  and  buttons will cycle between Master with flash, Master without flash, Slave, OS and Off modes.

4. Select Master with flash or Master without flash.

5. Pressing  button will change the highlighted selection from Master to Channel and Ratio.



6. Select the transmission channel.

7. Select the Ratio mode. Pressing the  and  buttons will cycle between A+B+C, A:B and A:BC modes.

8. Press the  button to confirm and exit the screen.

9. Press the  button to adjust power levels.

10. Pressing the  or  buttons will change the Flash Power Level (1/1 to 1/128 in 1/3rd stops).

11. Pressing the  button will change the Groups from A to B to C, the  button from C to B to A (if applicable).

12. Press the  button to exit power level adjustment mode.

















Multi Mode

A+B+C All three groups fire in Multi Mode at the same power level, frequency and flash count.

A:BC The output level of each group is adjusted individually by the user (see below). The frequency and flash count of the multi strobe of each group are same and can only be adjusted on Group A.



A:B Groups A and B can be set by power level individually by the user (see below). The frequency and flash count of the multi strobe of Groups A and B are same and can only be adjusted on Group A. Group C is not adjustable and does not fire.

Setting and Adjusting Multi Mode

1. Press the  button to change the flash into Multi Mode.
2. Press and hold the  button for 2 seconds to enter wireless mode.
3. Pressing the  and  buttons will cycle between Master with flash, Master without flash, Slave, OS and Off modes.
4. Select Master with flash or Master without flash.
5. Pressing  button will change the highlighted selection from Master to Channel and Ratio.
6. Select the transmission channel.
7. Select the Ratio mode. Pressing the  and  buttons will cycle between A+B+C, A:B and A:BC modes.
8. Press the  button to confirm and exit the screen.
9. Press the  button to adjust power levels.
10. Pressing the  or  buttons will change the Flash Power Level (1/1 to 1/128 in 1/3rd stops).
11. Pressing the  buttons will change the Groups from A to B to C, the  button from C to B to A (if applicable), and allow power level to be changed on these groups.
12. Pressing the  button after cycling through the groups will move to the frequency and flash count selections.
13. Pressing the  or  buttons will allow changes to be made to frequency and flash count. These setting can only be changed on Group A and will be applied to Group B or C (if applicable).
14. Press the  button to exit power level adjustment mode.

Custom Functions

The Phottix Mitros TTL Flash comes with a number of programmable custom functions. To edit these functions (below):

1. Press the  button for 2 seconds to enter the C.Fn Menu Screen.
2. Press the  or  buttons to cycle through the menu items – C.Fn 0 to 15.

3. Press the  or  buttons to change the function within the menu.

4. Press the  button to exit the C.Fn menu.

Custom Functions Chart

Custom Function No.	Functions	Setting No.	Settings and descriptions
C.Fn 00	Distance units	0-Meters(m)	Meters(m)
		1-Feet(Ft)	Feet(Ft)
C.Fn 01	Auto Idle	0-Enable	Enable
		1-Disable	Disable
C.Fn 02	Modeling flash	0-Depth of field	Enable (Depth of field button)
		1-Test firing key	Enable (Test firing key)
		2-Both	Enable (Depth of field button and Test firing key)
		3-Disable	Disable
C.Fn 03	FEB auto cancel	0-Enable	Enable
		1-Disable	Disable
C.Fn 04	FEB sequence	0-0 → - → +	0 → - → +
		1-- → 0 → +	- → 0 → +
C.Fn 06	Quick flash — 	0-Disable	Disable
		1-Enable	Enable
C.Fn 07	Test firing	0-1/32	at 1/32 power
		1-Full output	Full output
C.Fn 08	AF assist light	0-Enable	Enable
		1-Disable	Disable
C.Fn 09	Auto zoom	0-For sensor size	For sensor size
		1-Disable	Disable
C.Fn 10	Slave Idle timer	0-60 minutes	60 minutes
		1-10 minutes	10 minutes
C.Fn 11	Slave auto OFF	0- After 8 hours	After 8 hours
		1- After 1 hour	After 1 hour
C.Fn 12	Recycle power	0-Int. and Ext. source	Internal and external power source
		1-External Power	External Power source only
C.Fn 13	Beep confirm	0-Enable	Enable
		1-Disable	Disable
C.Fn 14	Auto backlight	0-Enable	Enable
		1-Disable	Disable
C.Fn 15	TTL Pref	+EV	Add EV
		-EV	Reduce EV

Quick Flash Function

The Quick Flash function allows the flash to fire at 1/6 to 1/2 of the full output. Quick Flash recycle times are faster. It helps for snap photography for near subjects.

Quick flash can be used for continuous drive modes, quick flash for continuous shot function can be enabled or disabled (see C.Fn-06 above).

Please note:

The Quick Flash Function makes flash firing a priority. Under-exposure could result if the subject is located to far from the camera.

Auto Backlight

The backlight will light up for 8 seconds and then go off if no buttons are pressed. When the auto backlight function is enabled, pressing any button will light it up after it goes off. When the auto backlight function is set to "disable", pressing the mode button will light it up.



TTL Pref

TTL may vary slightly when using the flash on different cameras. TTL Pref (C.Fn-15) setting allows users to adjust EV from +3 to -3 in 1/3rd stops to compensate for these slight variations. This adjustment is a personal preference based on camera standard TTL and will be stored in memory. When this EV level preference is set, this compensation will be used for images taken in TTL mode. This EV compensation will not be displayed on the LCD during regular use.

Resetting to Factory Defaults

The Phottix Mitros Flash can reset to factory defaults.

To reset the flash:

1. Press and hold the  and  buttons for 3 seconds.
2. The flash will reset to factory default settings.
3. All custom functions will be reset to factory defaults.

Flash Information Display

For technical support or firmware upgrade checking the Phottix Mitros information may be need. To display the hardware, software, icon library and serial number display:

1. Press the  button as the flash is turned on.
2. Press any button to cancel this display and enter the LCD screen.

Changes to the flash capacitor:

If the flash is not used for some time physical changes will take place within the flash's capacitor. Make sure to turn on the flash a minimum of 10 minutes every three months to prevent any physical changes.

Technical Specification

Modes: E-TTL and E-TTL II, Manual, and Multi Stroboscopic

Guide No.: 58/190 (at 105mm focal length, ISO 100 in meters/feet)

Flash coverage: 24-105mm (14mm with wide angle diffuser panel)

Auto zoom (Flash coverage automatically adjusts to match the lens focal length)

Manual zoom (Zoom can be adjusted by changing setting on the flash/camera)

Rotation: 360 degrees, Up-Down: -7 to 90 degrees.

FEC (Flash exposure compensation): Manual

FEB (Flash exposure bracketing): ±3 stops in 1/3 stop increments (Manual flash exposure compensation and FEB can be combined)

Sync modes: First Curtain Sync, Second Curtain Sync, and High Speed Sync

Stroboscopic flash: 1-199Hz

Flash exposure confirmation: Blue LED lamp lights up in E-TTL mode

Flash Recycling (with size-AA alkaline batteries)

Recycling time/Flash-ready indicator:

Normal flash: Approx.0.1-5 sec./Red LED indicator lamp lights up.

Quick flash: Approx.0.1-2.5 sec./Green LED indicator lamp lights up.

Internal power: Four size-AA alkaline batteries or size-AA Ni-MH batteries

External battery: Compatible with Phottix Battery Pack and Canon compact battery pack CP-E4 through specific adapter

Power saving: Non-wireless slave modes: 90 seconds, Wireless slave mode: 60 minutes

Wireless flash

Transmission method: Optical pulse

Channels: 4

Wireless options: OFF, Master, Slave and Optical Slave

Transmission range (Approx.): (Indoors:12-16m/39.36-52.48 ft., Outdoors: 7-9m/22.96-29.52 ft.,

Reception angle: ±40°(horizontal), ±30°(vertical)

Controlled slave groups: 3 (A, B, and C)

Flash ratio control: 1:8-1:1-8:1

Standby current: ≤100uA in sleep mode

Dimensions: (L x W x H): 202.8×77.5×58.3 mm

Weight: 427g (flash only, excluding batteries)

www.phottix.com