

For Customer in China

根据中华人民共和国信息产业部第39号令《电子信息产品污染控制管理办法》及标准中要求的“有毒有害物质或元素名称及含量”等信息，本产品相关信息请参考以下链接：

<http://pro.sony.com.cn>



SONY

DFS-900M

SONY®

Multi Format Switcher

Operating Instructions

Software Version 2.1

Before operating the unit, please read this manual thoroughly and retain it for future reference.

DFS-900M

出版日期：2011年8月

Printed on recycled paper.

<http://www.sony.net/>

Printed in Japan

© 2010 Sony Corporation



Owner's Record

The model and serial numbers are located on the bottom. Record these numbers in the spaces provided below. Refer to these numbers whenever you call upon your Sony dealer regarding this product.

Model No. _____ Serial No. _____

WARNING

To reduce the risk of fire or electric shock, do not expose this apparatus to rain or moisture.

To avoid electrical shock, do not open the cabinet. Refer servicing to qualified personnel only.

THIS APPARATUS MUST BE EARTHED.

For the customers in the U.S.A.

This equipment has been tested and found to comply with the limits for a Class A digital device, pursuant to Part 15 of the FCC Rules. These limits are designed to provide reasonable protection against harmful interference when the equipment is operated in a commercial environment. This equipment generates, uses, and can radiate radio frequency energy and, if not installed and used in accordance with the instruction manual, may cause harmful interference to radio communications. Operation of this equipment in a residential area is likely to cause harmful interference in which case the user will be required to correct the interference at his own expense.

You are cautioned that any changes or modifications not expressly approved in this manual could void your authority to operate this equipment.

All interface cables used to connect peripherals must be shielded in order to comply with the limits for a digital device pursuant to Subpart B of Part 15 of FCC Rules.

This device complies with Part 15 of the FCC Rules. Operation is subject to the following two conditions: (1) this device may not cause harmful interference, and (2) this device must accept any interference received, including interference that may cause undesired operation.

For the customers in Canada

This Class A digital apparatus complies with Canadian ICES-003.



This symbol is intended to alert the user to the presence of important operating and maintenance (servicing) instructions in the literature accompanying the appliance.

WARNING: THIS WARNING IS APPLICABLE FOR USA ONLY.

If used in USA, use the UL LISTED power cord specified below.

DO NOT USE ANY OTHER POWER CORD.

Plug Cap	Parallel blade with ground pin (NEMA 5-15P Configuration)
Cord	Type SJT, three 16 or 18 AWG wires
Length	Minimum 1.5m (4 ft .11in.), Less than 2.5 m (8 ft .3 in.)
Rating	Minimum 10A, 125V

Using this unit at a voltage other than 120V may require the use of a different line cord or attachment plug, or both. To reduce the risk of fire or electric shock, refer servicing to qualified service personnel.

WARNING: THIS WARNING IS APPLICABLE FOR OTHER COUNTRIES.

1. Use the approved Power Cord (3-core mains lead) / Appliance Connector / Plug with earthing-contacts that conforms to the safety regulations of each country if applicable.
2. Use the Power Cord (3-core mains lead) / Appliance Connector / Plug conforming to the proper ratings (Voltage, Ampere).

If you have questions on the use of the above Power Cord / Appliance Connector / Plug, please consult a qualified service personnel.

IMPORTANT (for BKDF-901/902)

The nameplate is located on the bottom.

For the customers in Europe

This product with the CE marking complies with the EMC Directive issued by the Commission of the European Community.

Compliance with this directive implies conformity to the following European standards:

- EN55103-1 : Electromagnetic Interference(Emission)
- EN55103-2 : Electromagnetic Susceptibility(Immunity)

This product is intended for use in the following Electromagnetic Environment: E4 (controlled EMC environment, ex. TV studio).

The manufacturer of this product is Sony Corporation, 1-7-1 Konan, Minato-ku, Tokyo, Japan.

The Authorized Representative for EMC and product safety is Sony Deutschland GmbH, Hedelfinger Strasse 61, 70327 Stuttgart, Germany. For any service or guarantee matters please refer to the addresses given in separate service or guarantee documents.

This apparatus shall not be used in the residential area.

For the customers in Europe, Australia and New Zealand

WARNING

This is a Class A product. In a domestic environment, this product may cause radio interference in which case the user may be required to take adequate measures.

For kundene i Norge

Dette utstyret kan kobles til et IT-strømfordelingssystem.

For DFS-900M

Attention-when the product is installed in Rack:

1. Prevention against overloading of branch circuit
When this product is installed in a rack and is supplied power from an outlet on the rack, please make sure that the rack does not overload the supply circuit.
2. Providing protective earth
When this product is installed in a rack and is supplied power from an outlet on the rack, please confirm that the outlet is provided with a suitable protective earth connection.
3. Internal air ambient temperature of the rack
When this product is installed in a rack, please make sure that the internal air ambient temperature of the rack is within the specified limit of this product.
4. Prevention against achieving hazardous condition due to uneven mechanical loading
When this product is installed in a rack, please make sure that the rack does not achieve hazardous condition due to uneven mechanical loading.
5. Install the equipment while taking the operating temperature of the equipment into consideration
For the operating temperature of the equipment, refer to the specifications of the Operation Manual.
6. When performing the installation, keep the following space away from walls in order to obtain proper exhaust and radiation of heat.
Right, Left : 10 cm (4 inches) or more
Rear : 10 cm (4 inches) or more

For BKDF-901/902

When installing the installation space must be secured in consideration of the ventilation and service operation.

- Do not block the ventilation slots at the left side and right side panels, and vents of the fans.
- Leave a space around the unit for ventilation.
- Leave more than 10 cm of space in the rear of the unit to secure the operation area.

When the unit is installed on the desk or the like, leave at least 10 cm of space in the left and right sides. Leaving 10 cm or more of space above the unit is recommended for service operation.

AVERTISSEMENT

Afin de réduire les risques d'incendie ou d'électrocution, ne pas exposer cet appareil à la pluie ou à l'humidité.

Afin d'écarter tout risque d'électrocution, garder le coffret fermé. Ne confier l'entretien de l'appareil qu'à un personnel qualifié.

CET APPAREIL DOIT ÊTRE RELIÉ À LA TERRE.

AVERTISSEMENT

1. Utilisez un cordon d'alimentation (câble secteur à 3 fils)/fiche femelle/fiche mâle avec des contacts de mise à la terre conformes à la réglementation de sécurité locale applicable.
2. Utilisez un cordon d'alimentation (câble secteur à 3 fils)/fiche femelle/fiche mâle avec des caractéristiques nominales (tension, ampérage) appropriées.

Pour toute question sur l'utilisation du cordon d'alimentation/fiche femelle/fiche mâle ci-dessus, consultez un technicien du service après-vente qualifié.

IMPORTANT (pour BKDF-901/902)

La plaque signalétique se situe sous l'appareil.

Pour les clients au Canada

Cet appareil numérique de la classe A est conforme à la norme NMB-003 du Canada.

Pour les clients en Europe

Ce produit portant la marque CE est conforme à la Directive sur la compatibilité électromagnétique (EMC) émise par la Commission de la Communauté européenne. La conformité à cette directive implique la conformité aux normes européennes suivantes:

- EN55103-1: Interférences électromagnétiques (émission)
 - EN55103-2: Sensibilité électromagnétique (immunité)
- Ce produit est prévu pour être utilisé dans l'environnement électromagnétique suivant: E4 (environnement EMC contrôlé, ex. studio de télévision).

Le fabricant de ce produit est Sony Corporation, 1-7-1 Konan, Minato-ku, Tokyo, Japon.

Le représentant autorisé pour EMC et la sécurité des produits est Sony Deutschland GmbH, Hedelfinger Strasse 61, 70327 Stuttgart, Allemagne. Pour toute question concernant le service ou la garantie, veuillez consulter les adresses indiquées dans les documents de service ou de garantie séparés.

Ne pas utiliser cet appareil dans une zone résidentielle.

Pour les clients en Europe, Australie et Nouvelle-Zélande

AVERTISSEMENT

Il s'agit d'un produit de Classe A. Dans un environnement domestique, cet appareil peut provoquer des interférences radio, dans ce cas l'utilisateur peut être amené à prendre des mesures appropriées.

WARNUNG

Um die Gefahr von Bränden oder elektrischen Schlägen zu verringern, darf dieses Gerät nicht Regen oder Feuchtigkeit ausgesetzt werden.

Um einen elektrischen Schlag zu vermeiden, darf das Gehäuse nicht geöffnet werden. Überlassen Sie Wartungsarbeiten stets nur qualifiziertem Fachpersonal.

DIESES GERÄT MUSS GEERDET WERDEN.

WARNUNG

1. Verwenden Sie ein geprüftes Netzkabel (3-adriges Stromkabel)/einen geprüften Geräteanschluss/einen geprüften Stecker mit Schutzkontakten entsprechend den Sicherheitsvorschriften, die im betreffenden Land gelten.
2. Verwenden Sie ein Netzkabel (3-adriges Stromkabel)/einen Geräteanschluss/einen Stecker mit den geeigneten Anschlusswerten (Volt, Ampere).

Wenn Sie Fragen zur Verwendung von Netzkabel/ Geräteanschluss/Stecker haben, wenden Sie sich bitte an qualifiziertes Kundendienstpersonal.

WICHTIG (für BKDF-901/902)

Das Namensschild befindet sich auf der Unterseite des Gerätes.

Für Kunden in Europa

Dieses Produkt besitzt die CE-Kennzeichnung und erfüllt die EMV-Richtlinie der EG-Kommission.

Angewandte Normen:

- EN55103-1: Elektromagnetische Verträglichkeit (Störaussendung)
- EN55103-2: Elektromagnetische Verträglichkeit (Störfestigkeit)

Für die folgende elektromagnetische Umgebung: E4 (kontrollierter EMV-Bereich, z.B. Fernsehstudio).

Der Hersteller dieses Produkts ist Sony Corporation, 1-7-1 Konan, Minato-ku, Tokyo, Japan.

Der autorisierte Repräsentant für EMV und Produktsicherheit ist Sony Deutschland GmbH, Hedelfinger Strasse 61, 70327 Stuttgart, Deutschland. Bei jeglichen Angelegenheiten in Bezug auf Kundendienst oder Garantie wenden Sie sich bitte an die in den separaten Kundendienst- oder Garantiedokumenten aufgeführten Anschriften.

Dieser Apparat darf nicht im Wohnbereich verwendet werden.

Für Kunden in Europa, Australien und Neuseeland

WARNUNG

Dies ist eine Einrichtung, welche die Funk-Entstörung nach Klasse A besitzt. Diese Einrichtung kann im Wohnbereich Funkstörungen verursachen; in diesem Fall kann vom Betreiber verlangt werden, angemessene Maßnahmen durchzuführen und dafür aufzukommen.

Table of Contents

Chapter 1 Overview

Features of This System	11
Functions Newly Supported in Version 2.0	12
Functions Newly Supported in Version 2.1	12

Chapter 2 Names and Functions of Parts

BKDF-901 1M/E Control Panel.....	13
BKDF-901 Operating Blocks	13
1 External Connections and Power Block	14
2 KEYER Block	14
3 KEY DELEGATION Block.....	15
4 Cross-Point Bus Block	15
5 Transition Block	15
6 Joystick Block	16
7 Numeric Keypad.....	17
8 DME/SETUP Block	18
9 Display Panel/Menu Control Block.....	19
BKDF-901 Rear Panel.....	19
BKDF-902 1.5M/E Control Panel.....	21
BKDF-902 Operating Blocks	21
1 External Connections and Power Block	22
2 KEYER Block	22
3 Key/AUX (Auxiliary) Bus Control Block.....	22
4 M/E Cross-Point Bus Block	23
5 PROGRAM/PRESET Cross-Point Bus Block	23
6 PROGRAM/PRESET Transition Block.....	24
7 DSK (Downstream Key)/Fade to Black Control Block	24
8 M/E Transition Block	25
9 DME/SETUP Block	25
10 Joystick Block	26
11 Numeric Keypad.....	26
12 Display Panel/Menu Control Block.....	26
BKDF-902 Rear Panel.....	26
DFS-900M Processor Unit.....	28
Front Panel	28
Rear Panel.....	28

Options	31
BKDF-910 4 SDI Input Board	31
BKDF-911 2 SD Video Input Board.....	31
BKDF-912 2 DVI Input Board.....	31
BKDF-960 4 SDI Output Board.....	31
BKDF-961 2 SD Video Output Board	31
BKDF-962 2 DVI Output Board	32
BKDF-990 Power Supply Unit	32
Other Options	32

Chapter 3 Preparations

Connecting Peripheral Devices.....	33
Connection Example 1: Live Recording / Playout System	33
Connection Example 2: System with Editor Connected	35
Connection Example 3: Connection to a Device Equipped with a DVI (DVI-I) Connector	37
Installing Optional Expansion Boards.....	39
Installing I/O Expansion Boards	39
Installing Function Expansion Boards	46
Installing the BKDF-990 Power Supply Unit	51
Connecting Up the Switcher.....	54
Changing the Internal Switch Setting in the Processor Unit (When Using the BKDF-902)	54
Connecting the Processor Unit and the Control Panel	57
Powering the System On	58
Menu Operations	63
Basic Menu Configuration	63
Displaying Menus.....	63
Operating in Menus	64
Menu Operations in the GUI Menus	64
Basic Switcher Settings	71
Setting the Video Format	71
Making Input and Output Reference Sync Signal Settings.....	73
Making Settings Related to Input Signals	74
Making Settings Related to Output Signals	89
Making Other Settings.....	104

Chapter 4 Basic Operations

Selecting Backgrounds	108
Switching Backgrounds	109
Cutting to a New Background	109
Cutting by using GPI output.....	111
Using Transitions to Switch to the Next Video (Mix and Wipe).....	111
Switching with Mix Transitions	113
Switching with Wipe and DME Wipe Transitions.....	115
Setting Transition Rates	117
Using Color Mattes	117
Assigning Color Mattes to Cross-Point Selection Buttons	117
Changing the Colors of Color Mattes.....	117
Using Color Mattes in Background Transitions.....	118
Using Internally Stored Still Images	118
Acquiring Still Image Files	118
Using Stored Still Images in Background Transitions	120
Using 32-bit TGA Still Image Files in Keys.....	120
Writing Still Images to USB Flash Drives	121
Deleting Still Image Files.....	121
Using Keys to Compose Video.....	122
Setting Up Keys.....	122
Inserting Keys by a Cut Transition.....	126
Inserting Keys by a Mix Transition.....	127
Inserting Keys by a Wipe or DME Wipe Transition.....	127
Changing Key Priorities	128
Applying DME Effects to Keys	129
Inserting Downstream Keys (with a Cut).....	129
Inserting Downstream Keys (with a Mix)	130
Using Fade to Black	131

Chapter 5 Adjusting Wipes and Keys

Customizing Wipe Patterns	132
Adding Borders to Wipe Patterns.....	132
Modifying Wipe Patterns	133
Registering User Patterns	133
Customizing DME Effects	134
Changing the Position, Shape, and Size of Images	134
Adding Borders to Images.....	137
Adding Trail Effects, and Changing the Color Type	139
Adjusting 3D DME Warp Effects	140

Adding Lighting Effects	146
Registering User Patterns	147
Applying Masks to Keys	147
Adding Edges to Keys.....	148
Masking Downstream Keys with Box Masks	150

Chapter 6 Registering Operations and Settings

Event Operations	151
Registering Events.....	151
Recalling Events.....	152
Deleting Events	155
Sequence Operations.....	156
Creating Sequences	156
Recalling Sequences.....	156
Playing Sequences	158
Editing Sequences	159
Deleting Sequences	160

Chapter 7 External Control Interface Settings

Serial Interface Settings	161
Communications Protocol Settings	162
Baud Rate Settings	162
Parity Bit Settings.....	162
GPI Input Settings.....	163
Tally Output Settings.....	164
GPI Output Settings.....	166

Chapter 8 Other Operations and Settings

Backing Up Data	167
Backing Up, Restoring, and Clearing All Data	168
Backing Up, Restoring, and Clearing System Data	168
Backing Up, Restoring, and Clearing File Data.....	168
Updating the System	169
Status Information	170
To display the Status sub menus	170
Option Board Information	171

Software Version Information	171
Alarms	171

Chapter 9 3D Mode

Overview	172
I/O of 3D Mode Signals	172
3D Mode Signal Assignments	173
System Settings	174
Switching to 3D Mode	174
Selecting the 2D/3D Mode of Stored Still Images	174
3D Mode Operations	175

Appendix

Menu Structure	176
Transition Menu (for Transition, Wipe, and DME Settings)	176
Keyer Menu (for Key Settings)	177
Still Store Menu (for Still Image Settings)	179
Sequence Event Menu (for Sequence and Event Registration)	179
Setup Menu (for System Settings)	180
DME Menu (for DME Settings)	183
Pattern List	189
Wipe	189
Mask	191
DME Wipe	192
Messages and Actions to Take	197
Updating the Software	202
Checking the Software Versions	202
Preparing for Software Update	202
Updating the Software	202
Performing Update Confirmation, Data Clear, and Data Restoration	203
Troubleshooting	205
Problems during Startup	205
Problems on Video Input and Output	205
Problems on Functions	206
Specifications	207
DFS-900M Processor Unit	207
BKDF-901 1M/E Control Panel	207
BKDF-902 1.5M/E Control Panel	208

Optional Products	208
Pin Assignments	211
Example Connection of GPI Input	214
Example Connection of Tally/GPI Output	214
External Dimensions	215
Glossary	218
Index	219

Features of This System

The DFS-900M Multi Format Video Switcher is a compact switcher incorporating Digital Multi Effects (DME) functionality, and supporting both SD and HD systems.

Multi-format support

The system supports 480i/59.94 and 576i/50 formats for an SD system, and 1080i/59.94, 1080i/50, 720p/59.94, and 720p/50 formats for an HD system. You can change the format selection with a simple menu operation.

Extensible inputs and outputs

Along with the standard equipment of SDI inputs and outputs (8 inputs, 4 outputs), the following inputs and outputs are available when optional expansion boards are installed.

- SDI inputs and outputs (four channels): BKDF-910/BKDF-960 (of the four channels, two channels provided with format converter)
- SD analog inputs and outputs (two channels): BKDF-911/BKDF-961
- DVI inputs and outputs (two channels): BKDF-912/BKDF-962

For details, see “Installing Optional Expansion Boards” (page 39)

Advanced special effects

As standard features, the system provides two DME channels and six keyers: four full-function keyers and two simple downstream keyers (DSKs). A further maximum of six optional DME channels enables warp and other visual effects.

Multi-view function

The optional multi-view function allows the system to display multiple video images on a single monitor, by splitting the screen into 4, 10, or 16 images. Using the maximum of two multi-view channels, all input video (24 channels) and program/preview output can be viewed simultaneously on just two monitors.

Simple operations in GUI menu screens

You can connect a PC monitor and USB mouse to make system settings in GUI menus.

You can also connect a commercially available touch panel monitor. This allows you to select menu items simply by touching the panel, making it much more convenient to change system settings and adjust setting values.

Compact and easy-to-use control panels

Two types of highly compact and easy-to-use control panels are available, each one designed to meet the requirements of space-limited applications. Together with the 3RU processor chassis, they are ideal for use in any situation where space is at a premium.

The BKDF-902 1.5 M/E Control Panel has a built-in redundant power supply as a standard feature, and allows you to select AUX outputs with key operations.

Functions Newly Supported in Version 2.0

Functions		See
Input and output of SD analog signals	BKDF-911 board (for input) BKDF-961 board (for output)	Chapters 2 and 3
DVI input and output	BKDF-912 board (for input) BKDF-962 board (for output)	Chapters 2 and 3
3D mode		Chapter 9
Turning ancillary data output on or off		Chapter 3
GPI output setting		Chapter 7

Functions Newly Supported in Version 2.1

Functions		See
Customizing DME effects and settings	Selecting global axis	Chapter 5
	Trail Settings	
	3D DME warp effects (Ripple, Swirl, Mosaic, Slats, Lens, Mirror)	
	Lighting Effects	
Adding Effect Patterns (No.100 to 184, 242 to 251)		Appendix
Description for operation of updating software		Appendix
Troubleshooting		Appendix

BKDF-901 1M/E Control Panel

BKDF-901 Operating Blocks

This section explains the functions of control panel parts by dividing them into nine blocks, as shown below.

For information about the rear panel of the control panel, see “BKDF-901 Rear Panel” (page 19).

For details, see the pages indicated within parentheses.

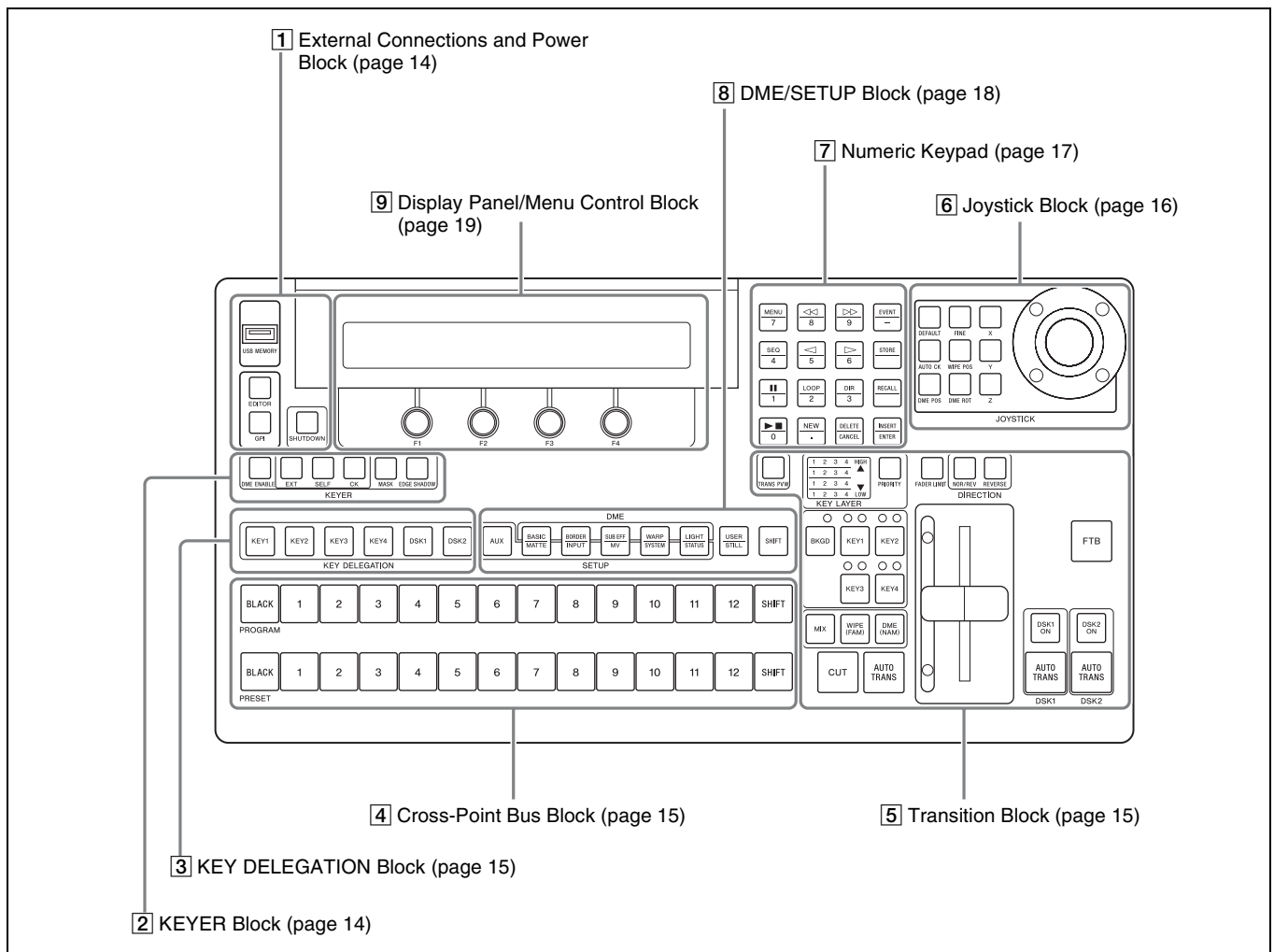

1 External Connections and Power Block

This block provides a connector for USB flash drives, buttons to turn control by editors and GPI on and off, and a button to start the shutdown process.

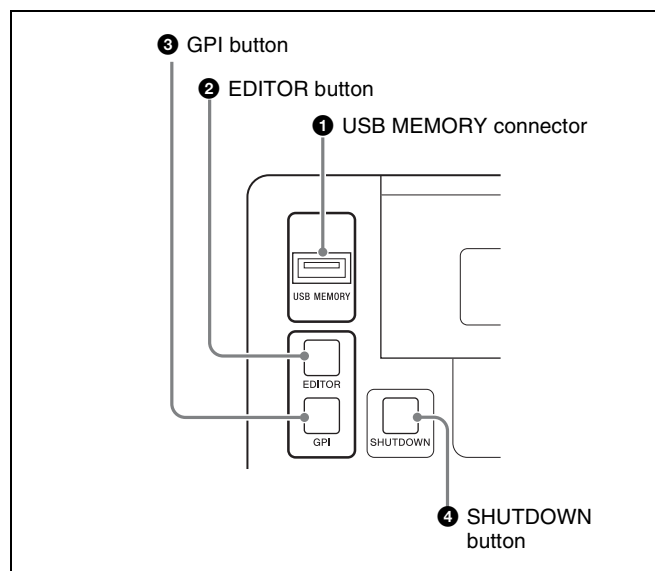

1 USB MEMORY connector (Type-A)

Use to connect a USB flash drive.

Note

The USB flash drive must be formatted with the FAT16 or FAT32 file system.

2 EDITOR button

Turns editor control on and off. When this button is on, you can control the switcher from an editor. When you turn this button on by pressing it twice in quick succession, the Serial menu for setup operations appears in the display panel.

3 GPI button

Turns GPI control on and off. When this button is on, you can perform GPI control of the switcher. When you turn this button on by pressing it twice in quick succession, the GPIO Tally menu appears in the display panel.

4 SHUTDOWN (start shutdown process) button

When you press this button, lighting it, the message “Shutdown? F2:OK F3:CANCEL” appears. Press the F2 knob to start data backup. When data backup finishes, you can power the switcher off by using the POWER switch on the rear panel of the control panel.

2 KEYER Block

This block allows you to select a key type, to add a mask or edge (shadow) to a key, and to enable or disable DME. The operation target key must be selected in advance (*see page 15*).

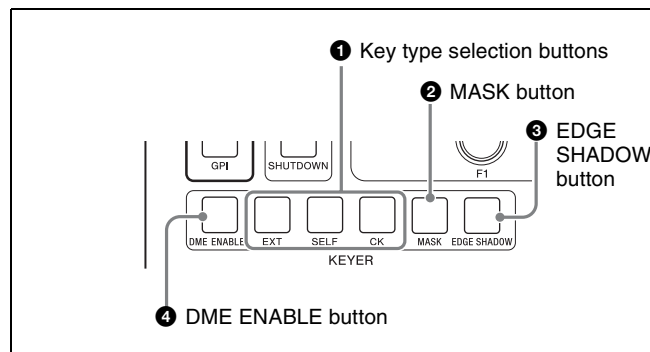

1 Key type selection buttons

Press one of the following buttons, lighting it, to select a key type.

EXT (external key) button: Press to create a key by using separate signals for the key fill and key source.

SELF (self key) button: Press to create a key by using the same signal for the key fill and key source.

CK (chroma key) button: Press to create a chroma key.

2 MASK button

Press this button, turning it on, to apply a mask to a key. When one of KEY1 to KEY4 is selected as the operation target, the Key Mask sub menu appears when you press this button. This menu allows you to select the mask pattern and to specify the center position and size of the mask.

When DSK1 or DSK2 is selected as the operation target, the Box Mask sub menu appears when you press this button. This menu allows you to specify a box mask position.

3 EDGE SHADOW button

Press this button, turning it on, to add an edge or shadow to the key. When you press this button with one of KEY1 to KEY4 selected, the Edge Type sub menu appears, allowing you to select the edge or shadow type, and to specify the width and the color.

4 DME ENABLE (enable/disable digital multi effects) button

Enables or disables DME for each of the BKGD (background) and KEY1 to KEY4 layers. This button functions as a three-step switch. With each press, the DME enable/disable state changes as follows, starting with the button not lit (DME disabled).

First press: DME is enabled. As the key, use a white signal for the entire screen.



Second press: With DME still enabled, use a key-processed signal as the key.



Third press: The button goes out, and DME is disabled again.

3 KEY DELEGATION Block

This block allows you to select KEY1 to KEY4, DSK1, or DSK2 as the target of key, mask, and other operations.

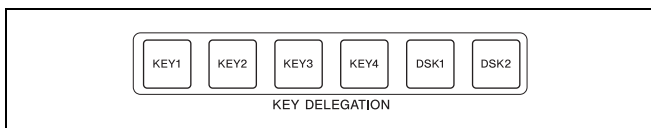

When you press one of the buttons in this block, it selects the corresponding key as the operation target. The pressed button lights in green and all of the other buttons go out.

If you press a button while it is lit in green, all of the buttons go out and key is not selected as the operation target.

The selection made here specifies the target of operations with buttons in the following blocks.

- KEYSER block
- DME settings buttons and USER button in the DME/SETUP block.
- AUTO CK, WIPE POS, DME POS, and DME ROT buttons in the joystick block.

Selections made with these buttons are linked to menu operations. Operations with the buttons may cause a menu to appear, and operations in the menu may cause the buttons to light or go out.

4 Cross-Point Bus Block

This block allows you to select material signals to use in creating the video.

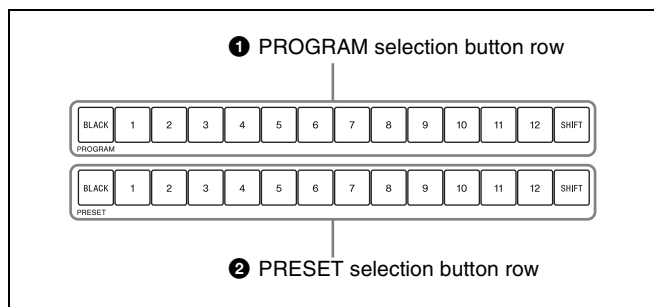

1 PROGRAM selection button row

These buttons select current on-air background video.

For the functions of the various buttons, see “Assigning video input signals to cross-point selection buttons” (page 76).

2 PRESET selection button row

These buttons select the video that will be the on-air background after a transition.

The signals that are assigned to the buttons in this row are the same as the signals that are assigned to the buttons in the PROGRAM selection button row.

About the SHIFT buttons

The SHIFT buttons on the right side of the PROGRAM and PRESET selection button rows allow you to switch between the two signals assigned to each button in the rows.

The SHIFT buttons have two operating modes: one in which the buttons function as shift buttons only while held down, and one in which the shift function is alternately enabled and disabled each time the buttons are pressed.

For details, see “Selecting the operating mode of the SHIFT buttons” (page 105).

5 Transition Block

This block allows you to set up and execute transitions.

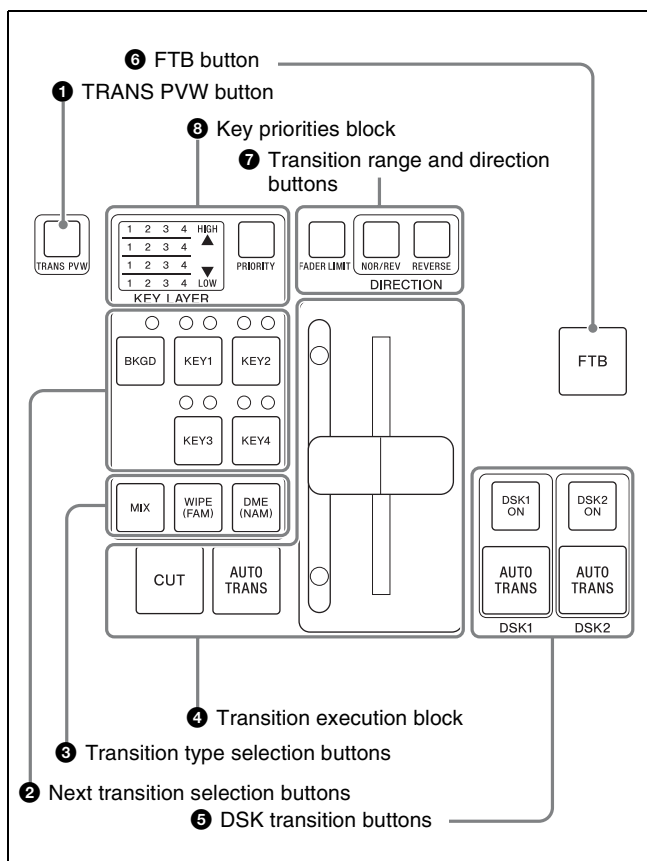

1 TRANS PVW (transition preview) button

Allows you to check the video of a transition before carrying out the transition.

When you press this button, lighting it, and then execute a transition with the fader lever, the video of the transition is output to the preview screen.

Notes

- A transition preview is not output when you execute the transition by using an AUTO TRANS button.
- A transition preview is not output when you execute a DME wipe.

2 Next transition selection buttons

Select the layer (BKGD, KEY1 to KEY4) to be used in a transition. You can select multiple layers. Pressed buttons light in orange. When a key is turned on, the Key On indicators (red) above the KEY1 to KEY4 buttons light. When DME effects are set for a layer, the DME indicator (green) above that layer lights.

3 Transition type selection buttons

MIX button: Press this button, lighting it, to select a mix transition. The Rate menu appears in the display panel, allowing you to specify the transition rate.

WIPE (FAM (full additive mix)) button: Press this button, lighting it, to select a wipe transition. The Wipe Pattern menu appears in the display panel, allowing you to select the wipe pattern. To select FAM, press this button while pressing the MIX button. Both buttons light.

DME (NAM (non-additive mix)) button: Press this button, lighting it, to use DME in a transition. The DME Pattern menu appears in the display panel, allowing you to select a DME wipe pattern. To select NAM, press this button while pressing the MIX button. Both buttons light.

4 Transition execution block

CUT button: Executes a cut transition. The current video changes instantly to the next video.

AUTO TRANS (auto transition) button: Executes an automatic transition. The video changes according to the currently specified transition rate.

Fader lever: Allows you to control a transition manually. The video changes according to the position of the fader lever as you move it up and down. You can limit the effective range of the fader lever, so that the transition is ended before you move it all the way to the top or bottom.

For information about how to limit the range, see “Limiting the effective range of the fader lever” (page 113).

5 DSK (downstream key) transition buttons

DSK1 ON and DSK2 ON buttons: Instantly inserts or deletes a downstream key. The button is turned on when a downstream key is inserted.

AUTO TRANS (auto transition) button: Executes a transition using a downstream key.

6 FTB (fade to black) button

Executes a transition in which the video changes to black. The transition rate is specified by a special fade-to-black setting.

7 Transition range and direction buttons

FADER LIMIT button: Limits the effective range of the fader lever. The range limitation is enabled when this button is pressed, lighting it. When you press the button twice to turn it on, the Fader Limit menu appears in the display panel. This menu allows you to specify the effective range of the fader lever as a percentage value. When you press the SHIFT button at the right side of the DME/SETUP block, the effective range is limited to the current fader lever position.

NOR/REV (normal/reverse) button: Press this button, lighting it, to reverse the direction of the transition each time a transition is executed.

REVERSE button: Press this button, lighting it, to execute a transition in the reverse direction.

8 Key priorities block

This block allows you to change the priorities of the four keys.

For information about how to change the priorities, see “Changing Key Priorities” (page 128).

6 Joystick Block

This block allows you to make settings related to positions on the screen.

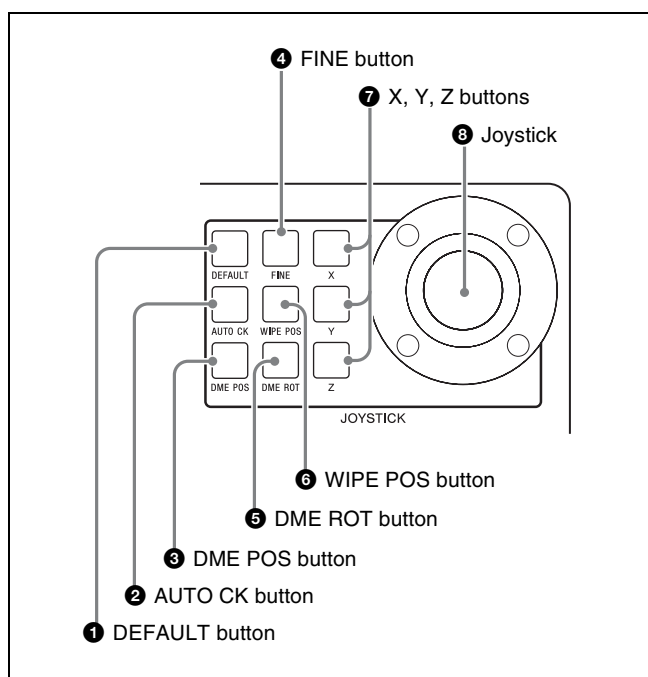

1 DEFAULT button

Returns the setting values of parameters assigned to the joystick to the default values.

2 AUTO CK (auto chroma key) button

Initiates and confirms the creation of an auto chroma key. Pressing this button once selects auto chroma key mode, in which you can select the color you want to use as the key color to cut out the foreground. Pressing it again confirms the creation of the auto chroma key and returns to manual adjustment mode (the CK Manual 1 menu appears in the display panel).

This button is enabled only when one of KEY1 to KEY4 is selected (see page 15).

For more information about how to create auto chroma keys, see “To create an auto chroma key” (page 123).

3 DME POS (DME image position) button

Displays the menu that allows you to specify the position of a DME image. To specify the position of a DME image with the joystick, press this button to display the menu and then adjust the position with the joystick.

4 FINE (fine adjustment) button

Selects fine adjustments to setting values when the joystick is moved. Press this button, lighting it, when you want to modify a setting value in small steps.

5 DME ROT (DME rotation angle) button

Displays the menu that allows you to specify the rotation angle of a DME image. You can adjust the angle with the joystick.

6 WIPE POS (wipe center position) button

Displays the menu that allows you to specify the center position of a wipe pattern. To specify the center position with the joystick, press this button to display the menu and then adjust the position with the joystick.

This button is enabled only when key is not selected as the operation target (see page 15).

7 X, Y, Z (parameter selection) buttons

Select parameters to adjust with the joystick. You can move the joystick to adjust the parameter selected by the lit button.

8 Joystick

As shown in the figure below, you can change X, Y, and Z coordinate parameters by moving the joystick left, right, up and down, or by rotating it to the left or right.

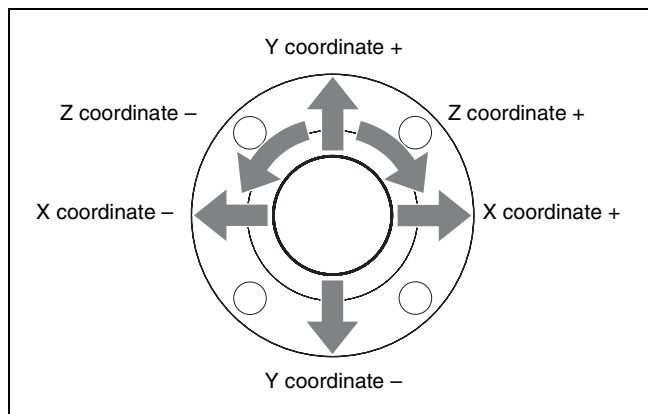

7 Numeric Keypad

The numeric keypad allows you to enter parameter values in menu operations.

When the current parameter has a settable value, you can press the corresponding knob F1 to F4 to enable direct input of a numeric value. Enter the value with the numeric buttons (0 to 9) and then press the ENTER button to confirm it. Press the CANCEL button to cancel the entry operation.

The buttons in the numeric keypad can also be used to switch between menu mode, event mode, and sequence mode, and to perform other operations according to the current mode.

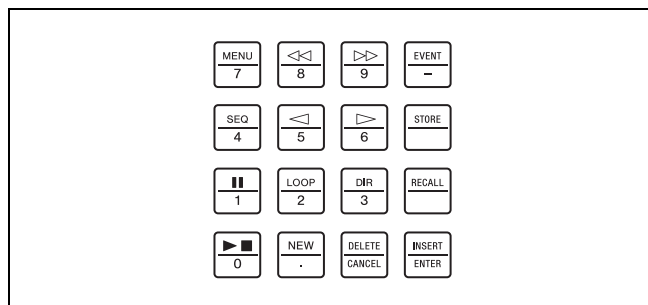

Buttons used to enter numeric values and symbols

Button display	Function
0 to 9	Enter numeric values.
.	Enters a decimal point (.).
-	Enters a minus sign (-).
CANCEL	Cancel numeric input.
ENTER	Confirm numeric input.

Buttons used when the MENU button is lit (menu mode)

Button display	Function
<<	Switches to the previous menu.

Button display	Function
▷▷	Switches to the next menu.
EVENT	Switches to event mode.
SEQ	Switches to sequence mode.
◁	Switches to the previous sub menu.
▷	Switches to the next sub menu.

Buttons used when the EVENT button is lit (event mode)

Button display	Function
EVENT	Exits event mode and switches to menu mode.
STORE	Stores an event.
RECALL	Recalls an event.
INSERT	Specifies settings to be recalled in event mode.

Buttons used when the SEQ button is lit (sequence mode)

Button display	Function
SEQ	Exits sequence mode and switches to menu mode.
STORE	Stores a sequence.
	Pauses play of a sequence, or restarts play.
LOOP	Specifies loop play as the play mode of a sequence.
DIR	Reverses the direction of play.
RECALL	Recalls a sequence.
▶■	Starts play of a sequence, or stops play.
NEW	Clears sequence memory.
DELETE	Deletes a sequence or key frame.
INSERT	Inserts a key frame.
◁, ▷	Moves the current key frame.
◁◁, ▷▷	Switches the sequence menu.

8 DME/SETUP Block

This block provides buttons for use in DME setting and setup operations.

When the SHIFT button on the right side is not lit, the buttons function as DME setting buttons (top-side indications on the buttons). When the SHIFT button is lit, the buttons function as setup buttons (bottom-side indications on the buttons).

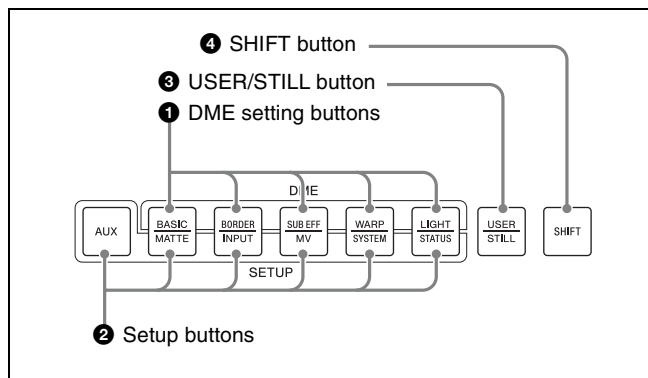

1 DME setting buttons

BASIC (basic DME settings) button: Displays a menu that allows you to make basic settings for DME images, such as position and rotation angle.

BORDER button: Displays a menu that allows you to set the color, width, softness and other attributes of borders added to DME images.

SUB EFF (sub effect) button: Displays a menu that allows you to add a Chroma Control sub effect to a DME image.

WARP button: Displays a menu that allows you to set up various warp patterns that can be applied by DME. After the menu appears, each press of the WARP button switches to the next pattern that can be set up.

LIGHT (light source) button: Displays a menu that allows you to specify and adjust light source effects added to 3D effects.

2 Setup buttons

AUX (auxiliary) button: Displays an AUX bus output menu that allows you to select the source, format, and level of output signals.

MATTE button: When pressed with the SHIFT button lit, displays a menu that allows you to select the luminance, saturation, and hue of internally generated color matte signals.

INPUT button: When pressed with the SHIFT button lit, displays a menu that allows you to make settings related to input signals, for example make settings for assigning input signals to a bus.

MV (multi-view) button: When pressed with the SHIFT button lit, displays a menu that allows you to select the number of child windows in the optional multi-view display and to select the signals to assign to each child window.

SYSTEM button: When pressed with the SHIFT button lit, displays a menu that allows you to make system settings, such as the video format, the system delay, and the date and time.

STATUS button: When pressed with the SHIFT button lit, displays a menu that allows you to check status information such as the installed option boards, the firmware version, and alarms.

3 USER/STILL button

When pressed with the SHIFT button unlit, displays the menu used for management of user specified wipe patterns and DME wipe patterns. When pressed with the SHIFT button lit, displays the menu for still image storage operations, such as download, capture, and export.

4 SHIFT button

Enables the functions of the STILL button and the setup buttons (except for the AUX button).

display area for four parameters. Useful supporting information for menu operations may appear in the upper right.

2 F1 to F4 knobs

The F1 to F4 adjustment knobs are located beneath the parameter display area. They correspond to up to four parameters per menu. You can set parameter values by rotating the knobs or by pressing a knob and entering the value for the corresponding parameter in the numeric keypad.

Instead of specifying parameter values, some menu items may select actions such as store or delete. To execute an action, press the corresponding knob and hold it down for one second or longer.

9 Display Panel/Menu Control Block

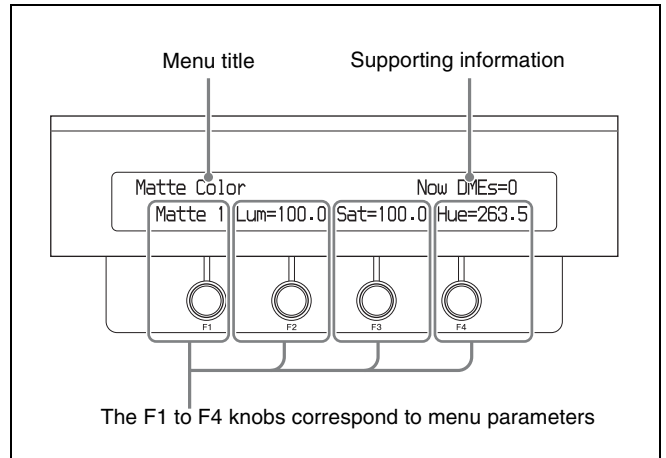
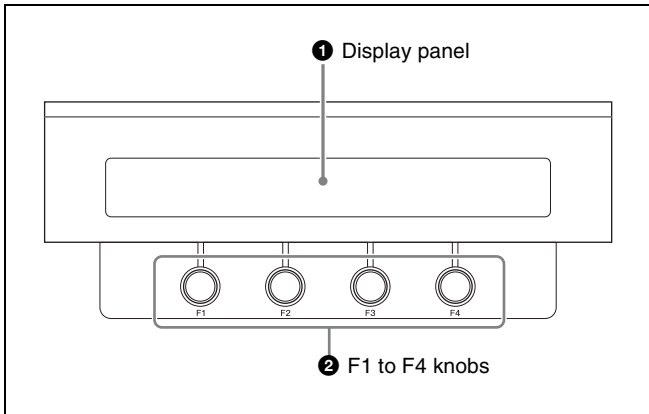

1 Display panel

Displays the operation and setting menus of the switcher. The menu title appears in the upper left. Below it is the

BKDF-901 Rear Panel

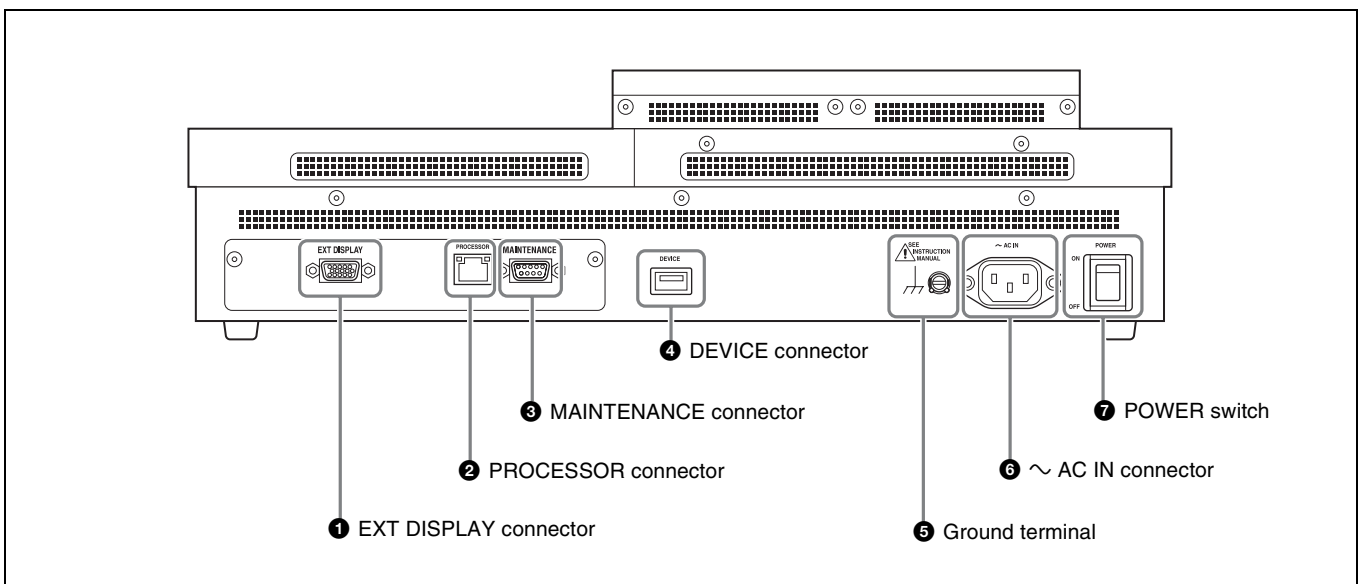

① EXT DISPLAY (external display) connector (high-density D-sub 15-pin)

You can also connect an optional touch panel monitor.

② PROCESSOR connector (RJ-45)

Use the supplied control cable to connect to the PANEL connector of the processor unit.

Note

This connector is for connection to the DFS-900M processor unit only. It cannot be connected to the processor unit of any other system.

CAUTION

- When you connect the PROCESSOR connector of the unit to peripheral devices, use a shielded-type cable to prevent malfunction due to radiation noise.
- For safety, do not connect the connector for peripheral device wiring that might have excessive voltage to this port. Follow the instructions for this port.

ATTENTION

Par mesure de sécurité, ne raccordez pas le connecteur pour le câblage de périphériques pouvant avoir une tension excessive à ce port. Suivez les instructions pour ce port.

VORSICHT

Aus Sicherheitsgründen nicht mit einem Peripheriegerät-Anschluss verbinden, der zu starke Spannung für diese Buchse haben könnte. Folgen Sie den Anweisungen für diese Buchse.

③ MAINTENANCE connector (D-sub 9-pin)

Provided for inspection / maintenance. Not used for operating this system.

④ DEVICE connector (USB Type-A)

Allows you to connect an optional touch panel monitor or a mouse.

⑤ Ground terminal

Connect to the system ground wire.

⑥ ~ AC IN connector

Connect to an AC power with an AC power cord (not supplied).

⑦ POWER switch

Powers the control panel on and off.

BKDF-902 1.5M/E Control Panel

BKDF-902 Operating Blocks

This section explains the functions of control panel parts by dividing them into twelve blocks, as shown below. For details, see the pages indicated within parentheses.

For information about the rear panel of the control panel, see “BKDF-902 Rear Panel” (page 26).

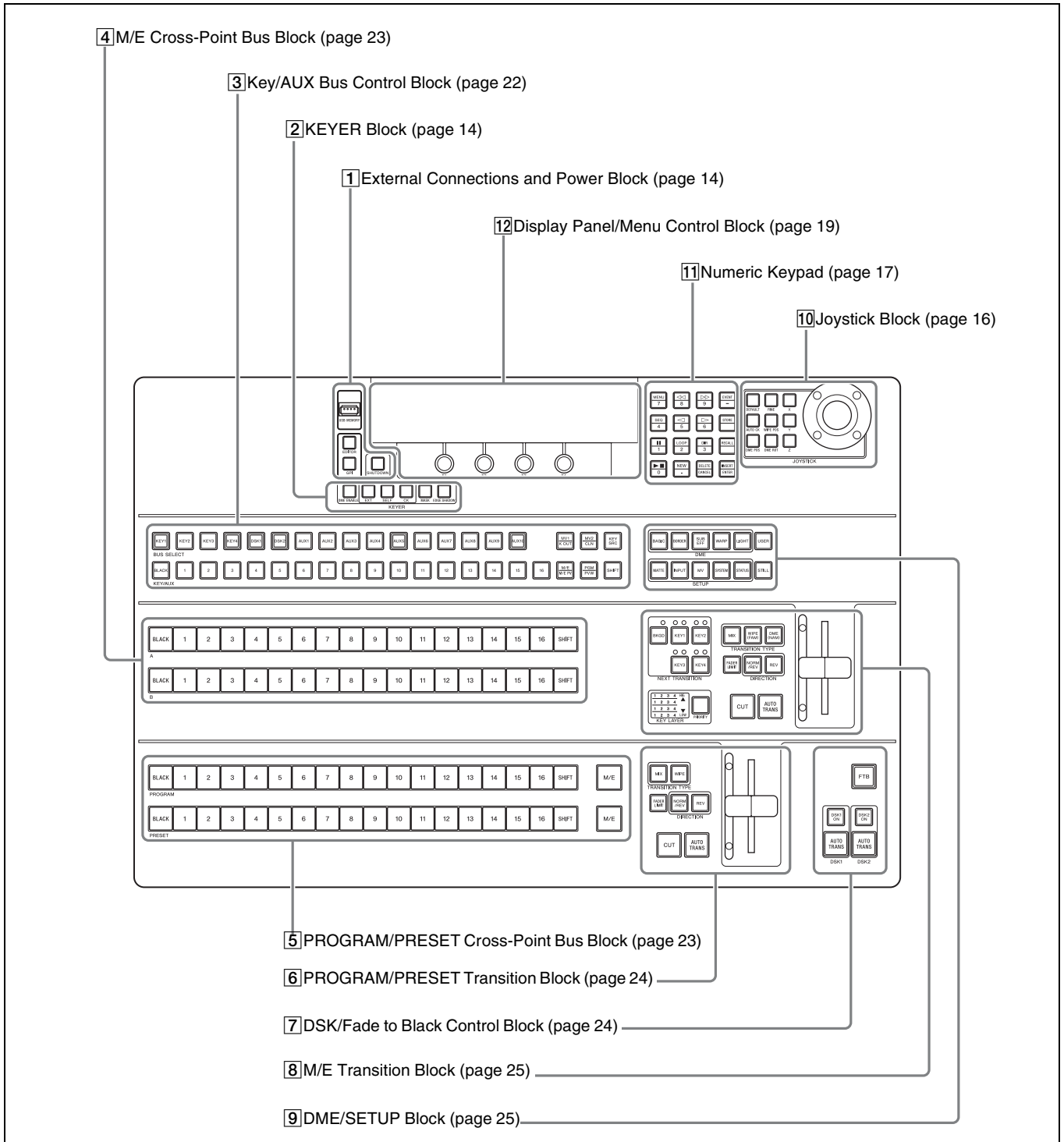

1 External Connections and Power Block

See descriptions for the BKDF-901 in “1 External Connections and Power Block” (page 14).

2 KEYER Block

See descriptions for the BKDF-901 in “2 KEYER Block” (page 14).

3 Key/AUX (Auxiliary) Bus Control Block

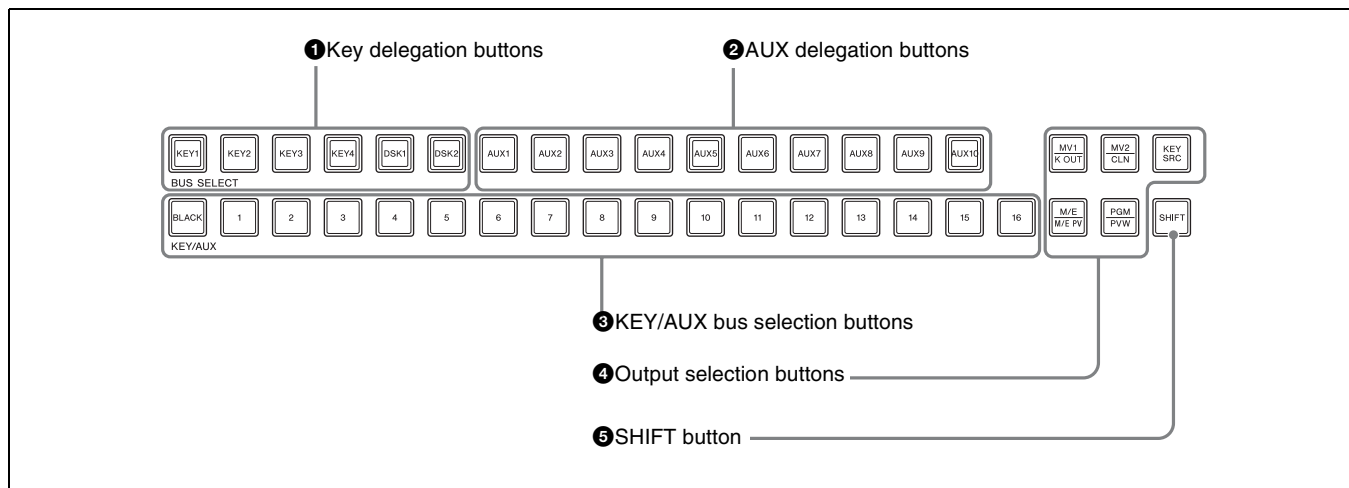

1 Key delegation buttons

See descriptions for the BKDF-901 in “3 KEY DELEGATION Block” (page 15).

2 AUX (Auxiliary) delegation buttons

Select the AUX bus output (AUX1 to AUX10) to which one of the KEY/AUX bus selection buttons or of the output selection buttons (MV1/K OUT, KEY SRC) is assigned. Signals selected with the KEY/AUX bus selection buttons or the output selection buttons are output to the bus selected here.

Press one of the buttons to display an AUX bus output menu that allows you to select the source, format, and level of AUX output signals.

Note

When optional expansion boards are not installed, the AUX3 to AUX10 buttons are disabled.

3 KEY/AUX (auxiliary) bus selection buttons

Select the output of the bus selected with the key delegation buttons or the AUX delegation buttons. The signals which can be selected with each button are the same as the signals selected by the corresponding buttons in the M/E cross-point bus block (see page 23).

4 Output selection buttons

Select the output of the bus selected with the key delegation buttons or the AUX delegation buttons.

MV1 (multi-view 1)/K OUT (key output) button:

Selects the multi-view 1 output when pressed with the SHIFT button unlit. Selects the key output of the M/E bus when pressed with the SHIFT button lit.

MV2 (multi-view 2)/CLN (clean) button: Selects multi-view outputs 2 when pressed with the SHIFT button unlit. Selects clean outputs when pressed with the SHIFT button lit.

KEY SRC (key source) button: Selects key source outputs. This button is also used to restore the default values for all settings (to reset all settings) in a sub menu of the DME menu (see page 134), to limit the effective range of the fader lever (see page 113), or to recall or delete events (see page 154 or page 155).

M/E / M/E PV (M/E preview) button: Selects the program output of the M/E bus when pressed with the SHIFT button unlit. Selects the preview output of the M/E bus when pressed with the SHIFT button lit.

PGM (program)/PVW (preview) button: Selects the program output when pressed with the SHIFT button unlit. Selects the preview output when pressed with the SHIFT button lit.

5 SHIFT button

Switches the functions of the MV1/K OUT button, MV2/CLN button, M/E / M/E PV button, and PGM/PVW button.

This button also allows you to switch between the two signals assigned to each KEY/AUX bus selection button.

The SHIFT buttons have two operating modes: one in which the buttons function as shift buttons only while held down, and one in which the shift function is alternately enabled and disabled each time the buttons are pressed.

For details, see “Selecting the operating mode of the SHIFT buttons” (page 105).

4 M/E Cross-Point Bus Block

This block allows you to select material signals to use in creating the video.

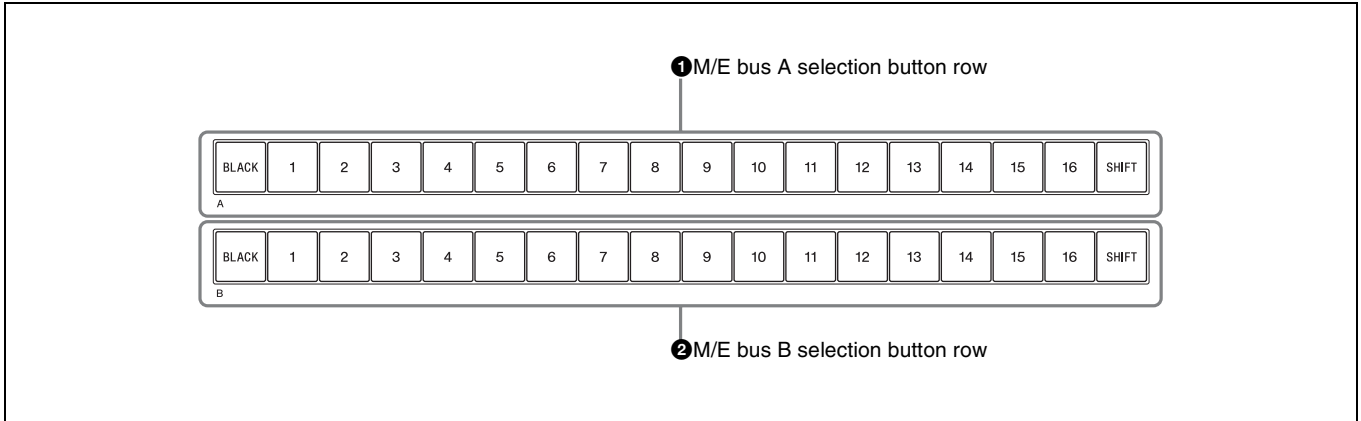

1 M/E bus A selection button row

Select the background A bus video which is output before the start of a transition (video switching).

For the functions of the various buttons, see “Assigning video input signals to cross-point selection buttons” (page 76).

2 M/E bus B selection button row

Select the background B bus video which is output after the start of a transition.

For the functions of the various buttons, see “Assigning video input signals to cross-point selection buttons” (page 76).

About the SHIFT buttons

The SHIFT buttons on the right side of each selection button rows allow you to switch between the two signals assigned to each button in the rows.

The SHIFT buttons have two operating modes: one in which the buttons function as shift buttons only while held down, and one in which the shift function is alternately enabled and disabled each time the buttons are pressed.

For details, see “Selecting the operating mode of the SHIFT buttons” (page 105).

5 PROGRAM/PRESET Cross-Point Bus Block

This block allows you to select material signals to use in creating the video.

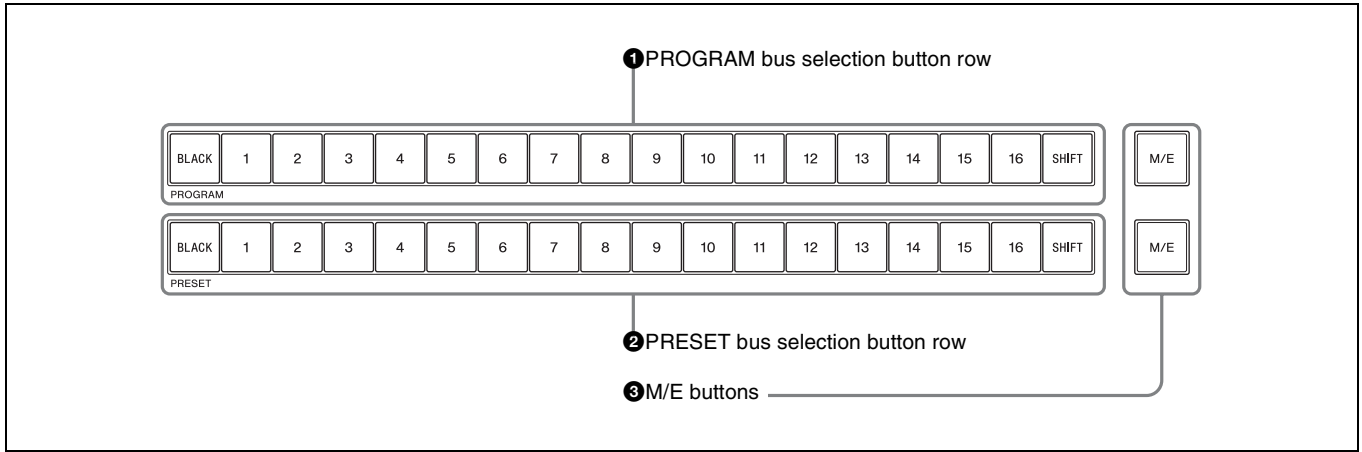

1 PROGRAM bus selection button row

See descriptions for the BKDF-901 in “PROGRAM selection button row” and “About the SHIFT buttons” (page 15).

2 PRESET bus selection button row

See descriptions for the BKDF-901 in “PRESET selection button row” and “About the SHIFT buttons” (page 15).

3 M/E buttons

Select the M/E program video created with the M/E Cross-Point Bus Block as background video.

6 PROGRAM/PRESET Transition Block

This block allows you to set up and execute transitions of program/preset video.

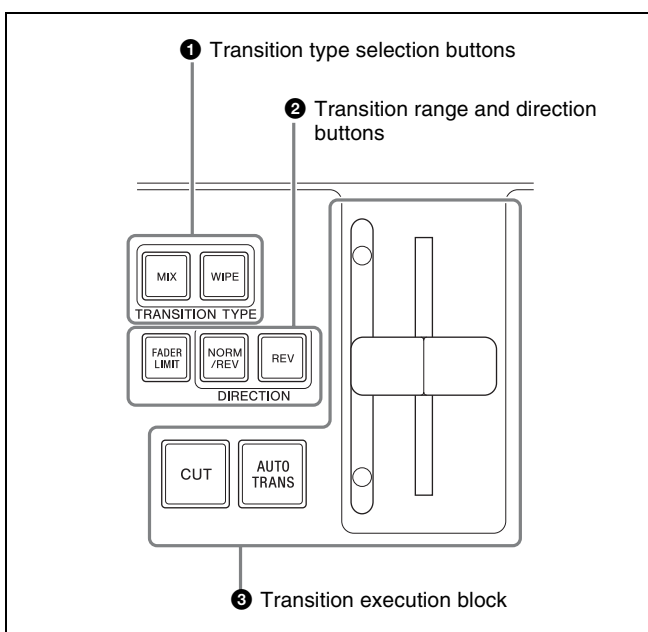

1 Transition type selection buttons

MIX button: Press this button, lighting it, to select a mix transition. The Rate menu appears in the display panel, allowing you to specify the transition rate.

WIPE button: Press this button, lighting it, to select a wipe transition. The P/P Wipe Pattern menu appears in the display panel, allowing you to select the wipe pattern.

2 Transition range and direction buttons

FADER LIMIT button: Limits the effective range of the fader lever. The range limitation is enabled when this button is pressed, lighting it. When you press the button twice to turn it on, the Fader Limit menu appears in the display panel. This menu allows you to specify the effective range of the fader lever as a percentage value.

NORM/REV (normal/reverse) button: Press this button, lighting it, to reverse the direction of the transition each time a transition is executed.

REV (reverse) button: Press this button, lighting it, to execute a transition in the reverse direction.

3 Transition execution block

See descriptions for the BKDF-901 in “Transition execution block” (page 16).

7 DSK (Downstream Key)/Fade to Black Control Block

This block allows you to set up and execute downstream keying and fade to black.

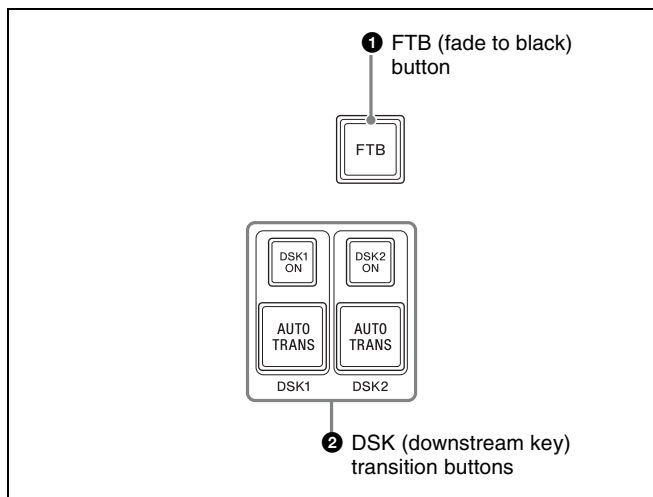

For functions of each button, see descriptions of “FTB (fade to black) button” (page 16) and “DSK (downstream key) transition buttons” (page 16) for the BKDF-901.

8 M/E Transition Block

This block allows you to set up and execute transitions of M/E video.

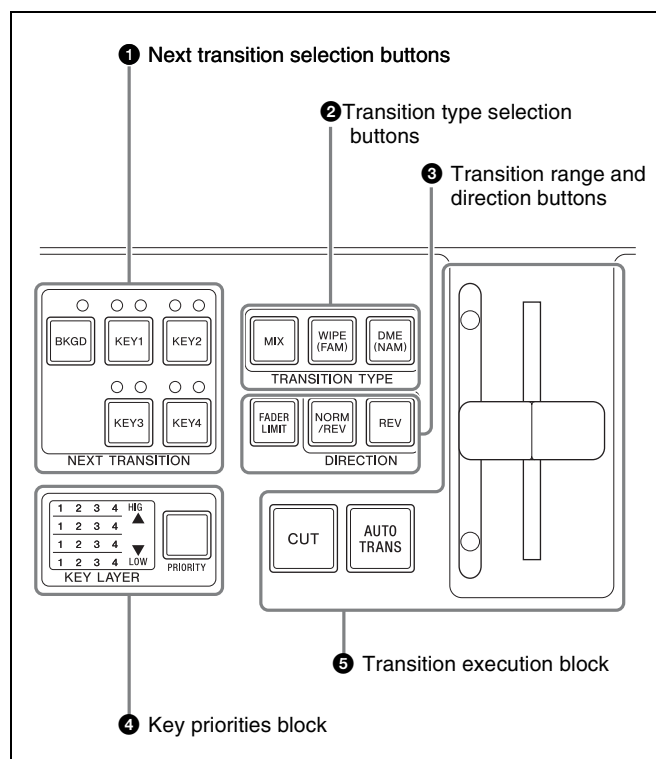

1 Next transition selection buttons

See descriptions of “Next transition selection buttons” (page 16) for the BKDF-901.

2 Transition type selection buttons

MIX button: Press this button, lighting it, to select a mix transition. The Rate menu appears in the display panel, allowing you to specify the transition rate.

WIPE (FAM (full additive mix)) button: Press this button, lighting it, to select a wipe transition. The M/E Wipe Pattern menu appears in the display panel, allowing you to select the wipe pattern.

To select FAM, press this button while pressing the MIX button. Both buttons light.

DME (NAM (non-additive mix)) button: Press this button, lighting it, to use DME in a transition. The DME Pattern menu appears in the display panel, allowing you to select a DME wipe pattern.

To select NAM, press this button while pressing the MIX button. Both buttons light.

3 Transition range and direction buttons

FADER LIMIT button: Limits the effective range of the fader lever. The range limitation is enabled when this button is pressed, lighting it. When you press the button twice to turn it on, the Fader Limit menu appears in the display panel. This menu allows you to specify the effective range of the fader lever as a percentage value.

NOR/REV (normal/reverse) button: Press this button, lighting it, to reverse the direction of the transition each time a transition is executed.

REV (reverse) button: Press this button, lighting it, to execute a transition in the reverse direction.

4 Key priorities block

See descriptions of “Transition execution block” (page 16) for the BKDF-901.

5 Transition execution block

See descriptions of “Key priorities block” (page 16) for the BKDF-901.

9 DME/SETUP Block

This block provides buttons for use in DME setting and setup operations.

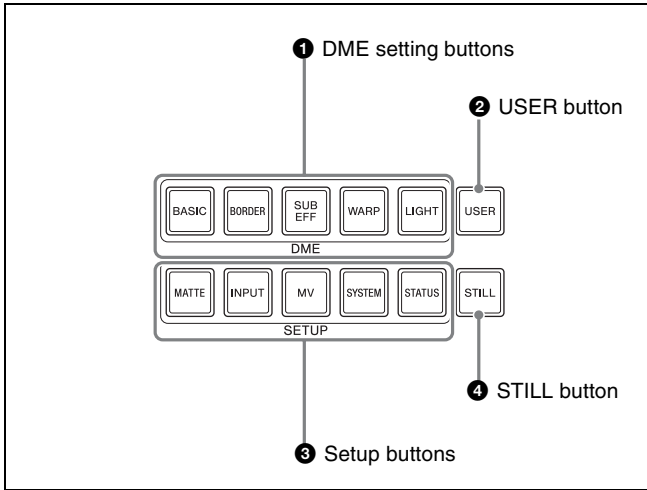

1 DME setting buttons

See descriptions of “DME setting buttons” (page 18) for the BKDF-901.

2 USER button

Displays the menu used for management of user specified wipe patterns and DME wipe patterns.

3 Setup buttons

See descriptions of “Setup buttons” (page 18) for the BKDF-901.

4 STILL button

Displays the menu for still image storage operations, such as download, capture, and export.

10 Joystick Block

See descriptions for the BKDF-901 in “6 Joystick Block” (page 16).

11 Numeric Keypad

See descriptions for the BKDF-901 in “7 Numeric Keypad” (page 17).

12 Display Panel/Menu Control Block

See descriptions for the BKDF-901 in “9 Display Panel/Menu Control Block” (page 19).

BKDF-902 Rear Panel

Two \sim AC IN connectors (A and B) and two POWER switches (A and B) are provided with the BKDF-902.

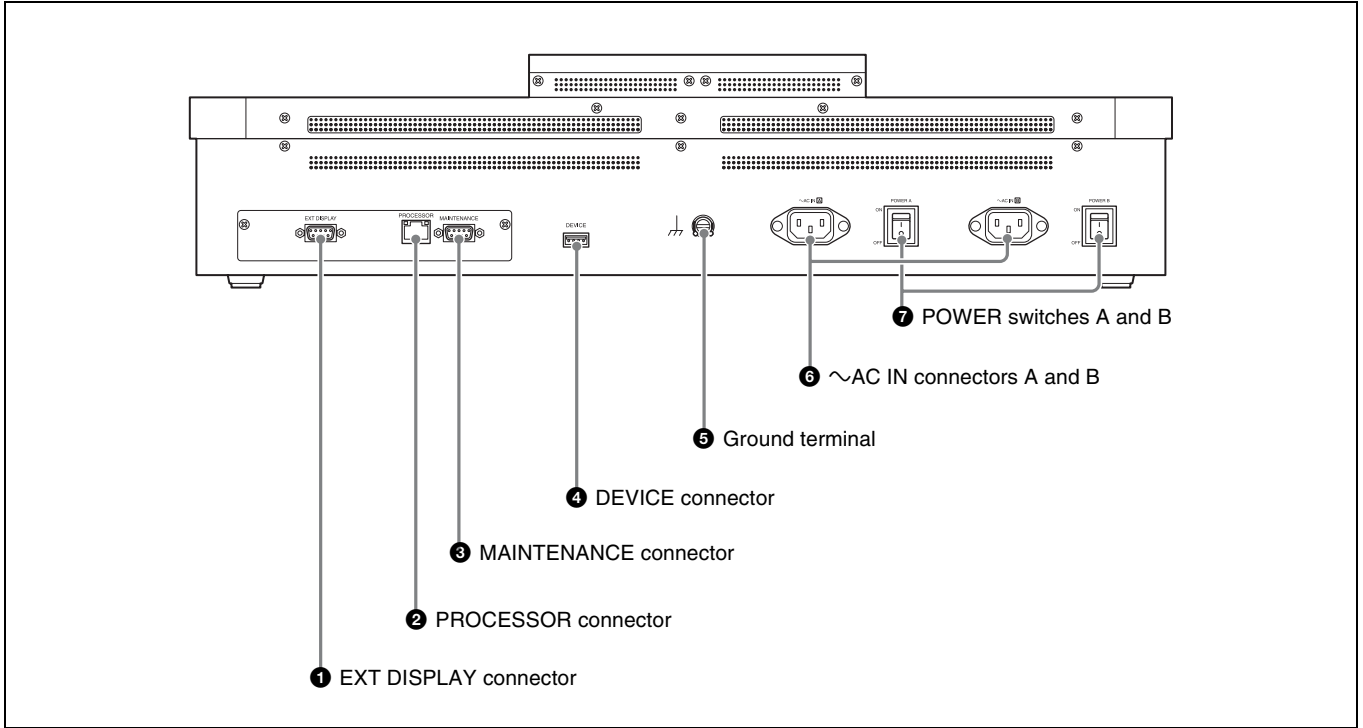

On how to use each connectors and switches, see descriptions in “BKDF-901 Rear Panel” (page 19).

DFS-900M Processor Unit

Front Panel

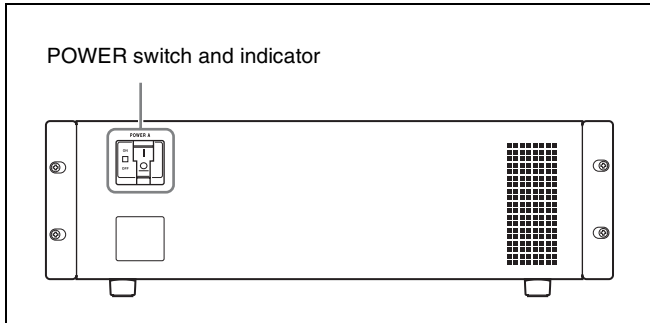

POWER switch and indicator

Powers the processor unit on and off. Press the **I** of the switch to power the unit on. The indicator lights in green when the unit is powered on.

You can install the optional BKDF-990 Power Supply Unit for use as a backup power supply. When installed, the BKDF-990 provides an additional power switch below the power switch of the standard power supply unit.

For details, see “Installing the BKDF-990 Power Supply Unit” (page 51).

Rear Panel

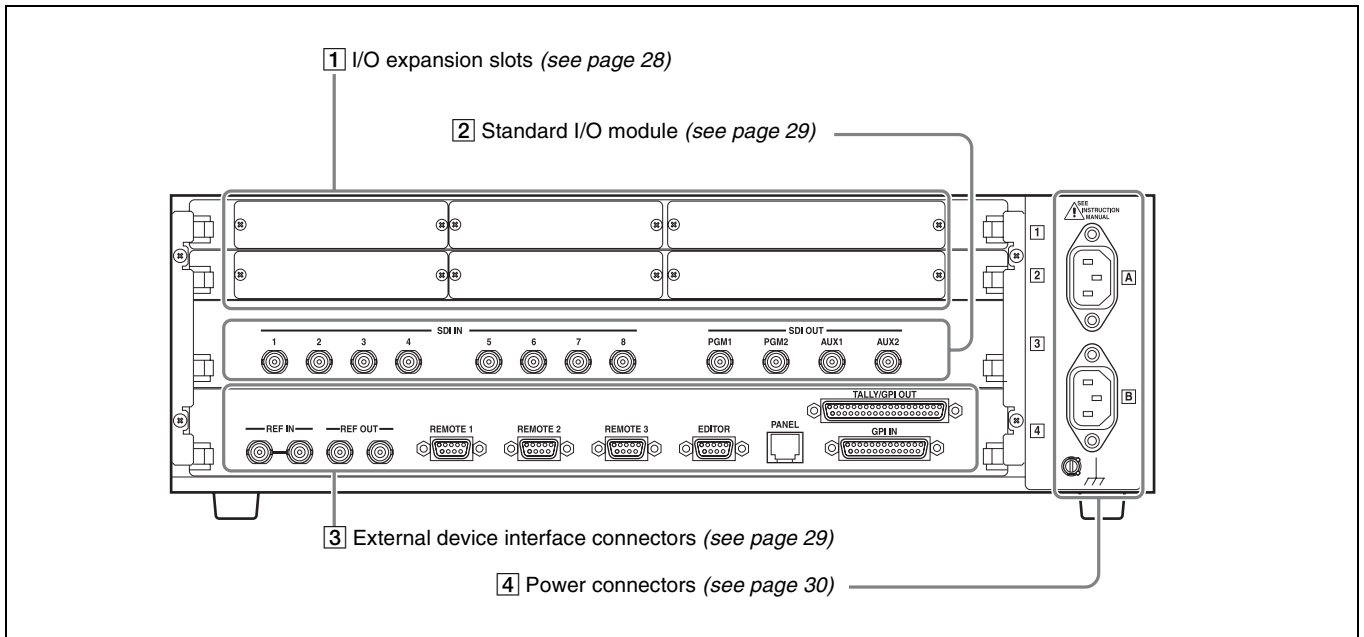

1 I/O expansion slots

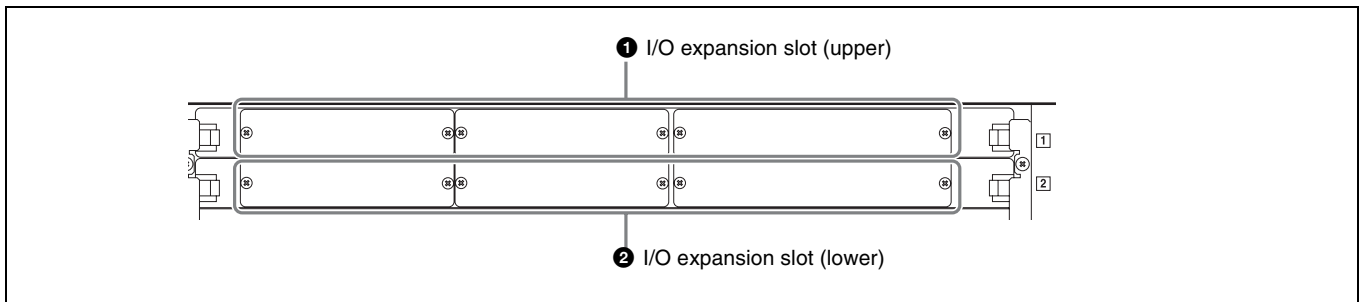

1 I/O expansion slot (upper)

In one slot, you can install two input expansion boards

(third and fourth boards) and one output expansion board (second board).

2 I/O expansion slot (lower)

In one slot you can install two input expansion boards (first and second boards) and one output expansion board (first board).

For details, see “Installing I/O Expansion Boards” (page 39).

2 Standard I/O module

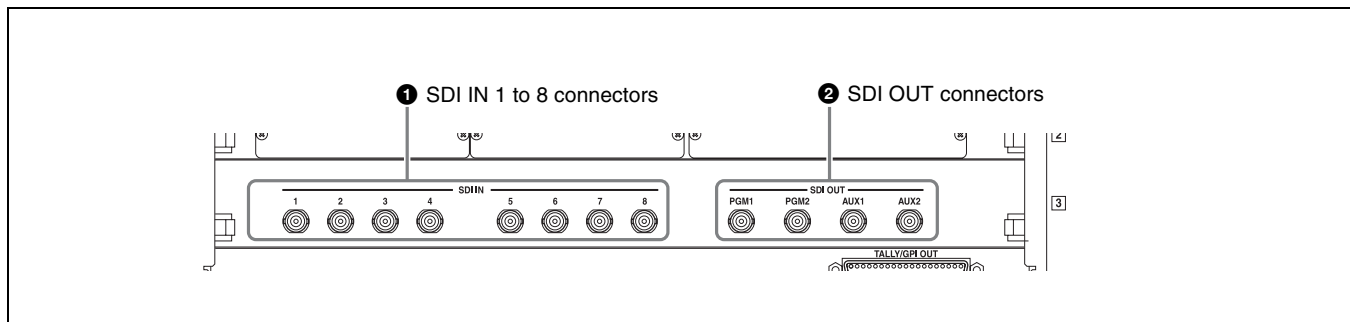

1 SDI IN (SDI input) 1 to 8 connectors (BNC type)

Input SDI signals from video cameras and VTRs (players). Internal frame synchronizers are provided, allowing input of non-synchronized video signals.

2 SDI OUT (SDI output) connectors (BNC type)

Output SDI signals. There are four SDI output connectors: PGM1, PGM2, AUX1, and AUX2.

PGM1, 2 (program 1, 2) connectors: Connect to the SDI input connectors of monitors or other devices. These connectors output the signals processed by this unit (program signals). The PGM1 and PGM2 connectors output the same signals.

AUX1, 2 (auxiliary 1, 2) connectors: Connect to the SDI input connectors of monitors or other devices. These connectors can output the same signals as the PGM1, 2 connectors. They can also output other types of signals, including output preview (PVW) signals, clean (CLN) signals, key output (KeyOut) signals, multi-view (MV) signals, and the input signals of this unit (In01 to In24). You can specify output of different signals from the AUX1 connector and the AUX2 connector.

Note

Input signals In09 to In24 appear only when optional input expansion boards have been installed.

3 External device interface connectors

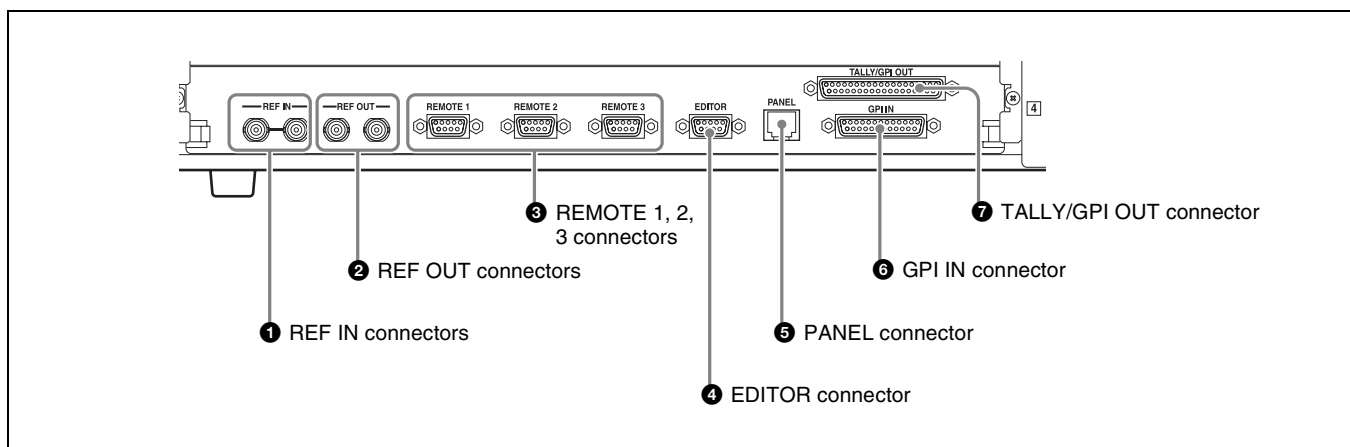

1 REF IN (reference sync signal input) connectors (BNC type)

Input an external reference sync signal. One of the connectors can be used as a loop-through output connector. If you will not be using loop-through output, terminate the connector with a 75 Ω terminator.

2 REF OUT (reference sync signal output) connectors (BNC type)

If you are not using an external reference sync signal to the REF IN connector, this connector outputs the internal sync signal used by the switcher as the reference signal.

③ REMOTE 1, 2, 3 connectors (D-sub 9-pin)

These connectors are provided for connections to devices that expand the functions of the switcher, such as the optional AUX bus remote controller.

④ EDITOR connector (D-sub 9-pin)

Connect an optional editing control unit. This connector is the same type as the REMOTE 1, 2, 3 connectors, but it is for use with an editor only.

⑤ PANEL connector (RJ-45)

Use the supplied control cable to connect to the PROCESSOR connector of the control panel.

Note

This connector is for connection to the DFS-900M control panel only. It cannot be connected to the control panel of any other system.

CAUTION

- When you connect the PANEL connector of the unit to peripheral devices, use a shielded-type cable to prevent malfunction due to radiation noise.
- For safety, do not connect the connector for peripheral device wiring that might have excessive voltage to this port. Follow the instructions for this port.

ATTENTION

Par mesure de sécurité, ne raccordez pas le connecteur pour le câblage de périphériques pouvant avoir une tension excessive à ce port. Suivez les instructions pour ce port.

VORSICHT

Aus Sicherheitsgründen nicht mit einem Peripheriegerät-Anschluss verbinden, der zu starke Spannung für diese Buchse haben könnte. Folgen Sie den Anweisungen für diese Buchse.

⑥ GPI IN (GPI input) connector (D-sub 25-pin)

GPI¹⁾ signals input to this connector can be used to execute transitions and other switcher operations from an external device connected to this unit.

1) GPI is an abbreviation of General-Purpose Interface.

⑦ TALLY/GPI OUT (tally/GPI output) connector (D-sub 37-pin)

You can connect this connector to the tally connector of a video camera. When the camera signals are being used, red and green tally signals are sent to light the tally indicators on the camera. This connector can also be used to send GPI signals from the switcher to a connected camera or other external device.

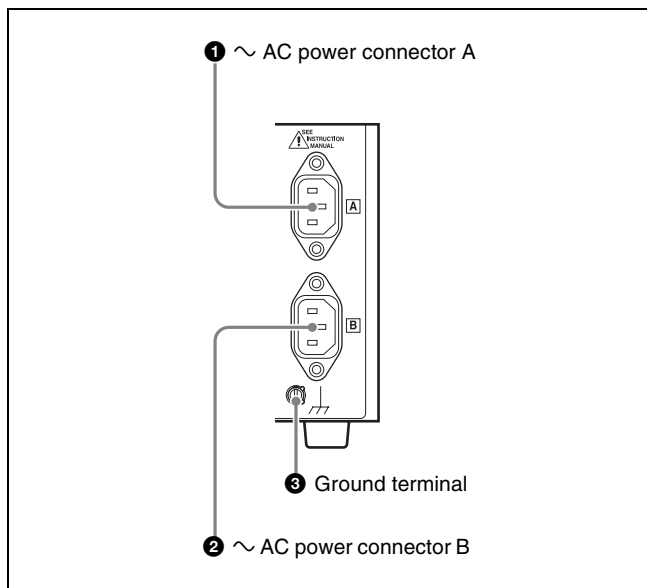
④ Power connectors**① ~ AC IN (AC power input) connector A**

Connect to an AC power supply with an AC power cord (not supplied).

② ~ AC IN connector B

This connector is available when an optional power supply unit is connected.

③ Ground terminal

Connect to the system ground wire.

Options

BKDF-910 4 SDI Input Board

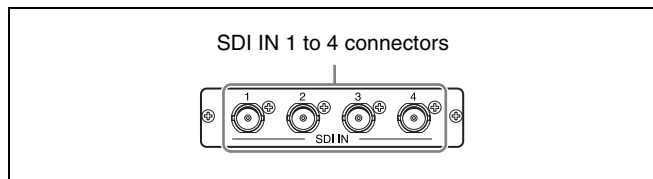

SDI IN (SDI input) 1 to 4 connectors (BNC type)

Input SDI signals. One board has four connectors, and up to four boards can be installed.

Together with the standard SDI input signals 1 to 8, this allows you to input up to a maximum of 24-SDI signals. Connectors 1 and 2 only are equipped with internal up-converters.

For details, see “Installing I/O Expansion Boards” (page 39) and “Making up-convert input settings” (page 81).

BKDF-911 2 SD Video Input Board

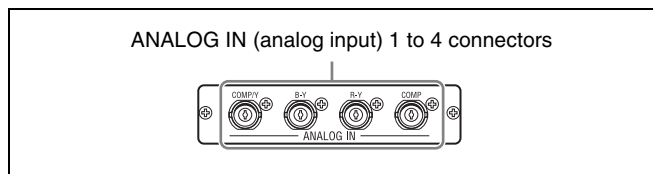

ANALOG IN (analog input) 1 to 4 connectors (BNC type)

Input SD analog signals. Both composite and component signals can be input.

The following table shows the name of each connector and input signals.

Connector number	Connector name	Input signals	
		Composite	Component
1	COMP/Y	Composite signal	Luminance signal (Y)
2	B-Y	Not used	Color difference signal (B-Y)
3	R-Y	Not used	Color difference signal (R-Y)
4	COMP	Composite signal	

For signal settings, see “Specifying the signal type of analog input signals” (page 83).

BKDF-912 2 DVI Input Board

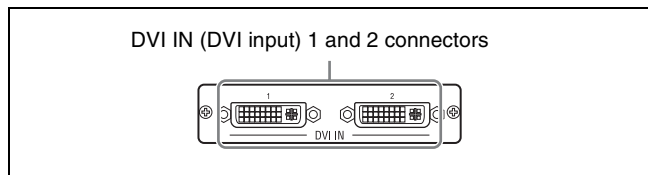

DVI IN (DVI input) 1 and 2 connectors (DVI-I type)

Connect a computer which is equipped with DVI output connectors.

For signal settings, see “Specifying the signal type of DVI input signals” (page 85).

BKDF-960 4 SDI Output Board

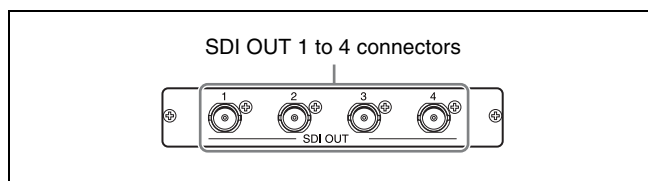

SDI OUT (SDI output) 1 to 4 connectors (BNC type)

Output SDI signals. One board has four connectors, and up to two boards can be installed.

Together with the standard SDI output signals 1 to 4, this allows you to output up to a maximum of 12 signals. Connectors 1 and 2 only are equipped with internal down-converters.

For details, see “Installing I/O Expansion Boards” (page 39) and “Making down-convert output settings” (page 91).

BKDF-961 2 SD Video Output Board

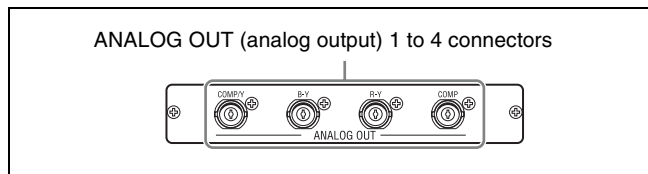

ANALOG OUT (analog output) 1 to 4 connectors (BNC type)

Output SD analog signals. Both composite and component signals can be output.

The following table shows the name of each connector and output signals.

Connector number	Connector name	Output signals	
		Composite	Component
1	COMP/Y	Composite signal	Luminance signal (Y)
2	B-Y	Not used	Color difference signal (B-Y)
3	R-Y	Not used	Color difference signal (R-Y)
4	COMP	Composite signal	

For signal settings, see “Specifying the signal type of analog output signals” (page 92).

- BKDF-950 Multi Viewer Board

BKDF-962 2 DVI Output Board

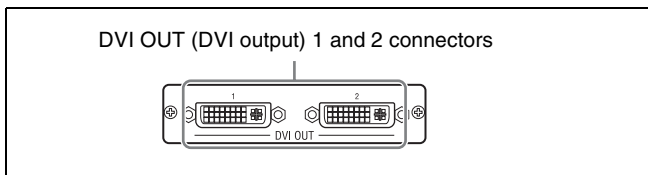

DVI OUT (DVI output) 1 and 2 connectors (DVI-I type)

Connect a computer display which is equipped with DVI input connectors.

For signal settings, see “Specifying the signal type of DVI output signals” (page 94).

BKDF-990 Power Supply Unit

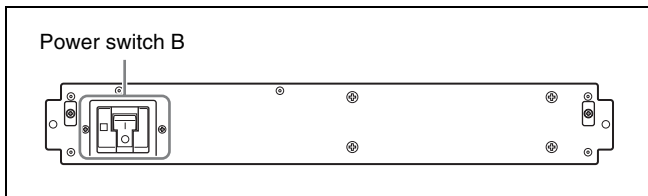

Power switch B

You can install the BKDF-990 Power Supply Unit in the lower rack of the processor unit. You can then use power switch B to turn it on and off as a backup power supply.

For details, see “Installing the BKDF-990 Power Supply Unit” (page 51).

Other Options

For details about the following options, see “Installing Function Expansion Boards” (page 46).

- BKDF-940 2CH DME Board

Connecting Peripheral Devices

This section provides examples of how to connect peripheral devices. After connecting a peripheral device to the switcher, use the menu system to make basic settings.

Notes

- When you connect a device that does not allow input of external sync signals, you can achieve synchronization by enabling the frame synchronizer of the input connector to which you have connected that device. For more information about how to enable frame synchronizers, see “Using the internal frame synchronizers” (page 79).
- The switcher has two REF IN connectors. When you are using a reference sync signal generator, and do not want to perform loop-through output of the reference sync signal input to one of the REF IN connectors of the switcher, attach a 75 Ω terminator to the other connector (see page 29). Also, use 75 Ω termination on all devices connected to the switcher. The method for connecting the termination depends on the connected device and the connection conditions. For details, refer to the operating instructions of the connected devices.

Connection Example 1: Live Recording / Playout System

The figure below shows an example of a system configured with this switcher, several video cameras, and video output devices for the addition of special effects.

Connect the SDI output of the output devices to the SDI IN connectors of the switcher.

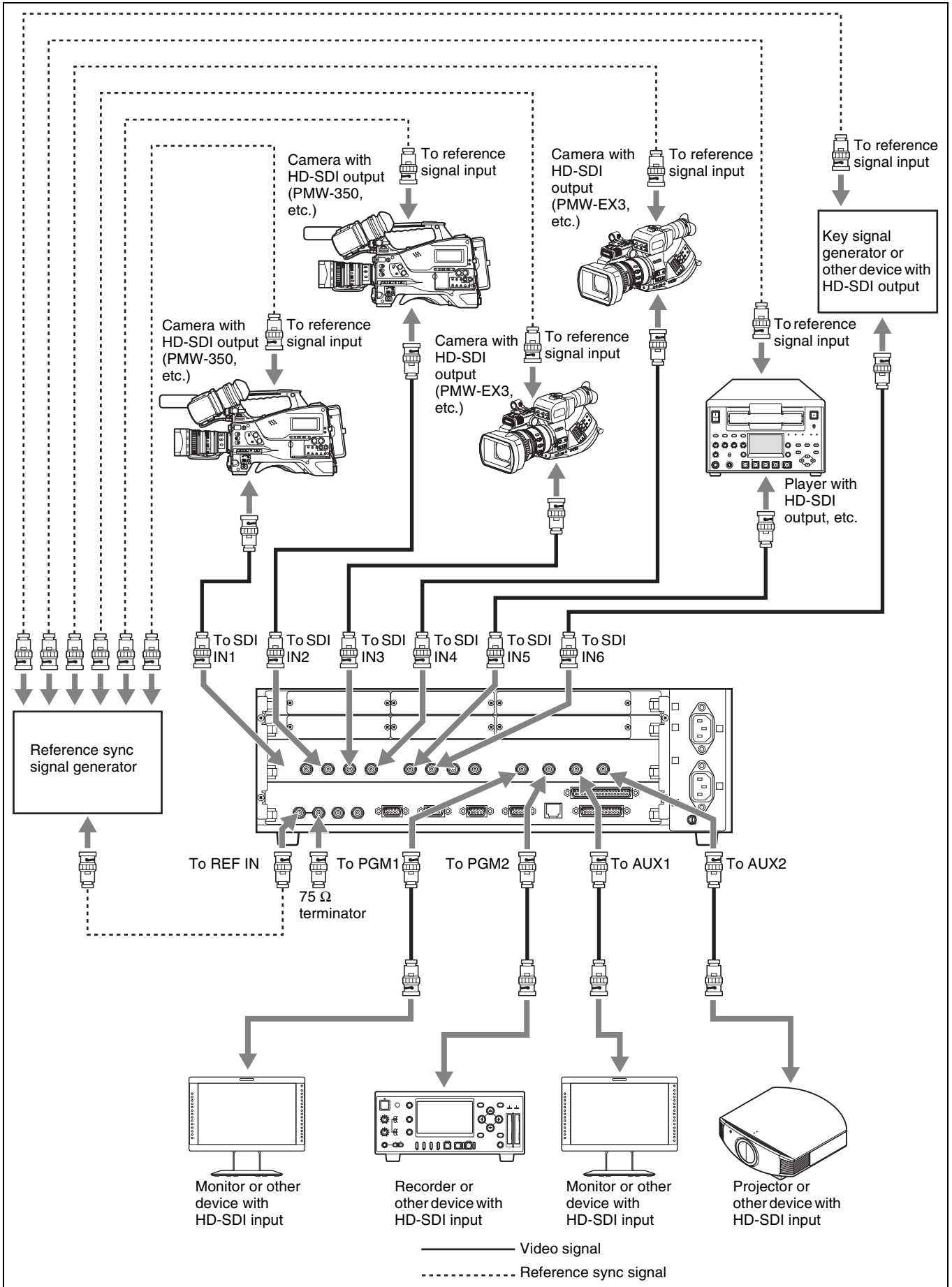

Connection Example 2: System with Editor Connected

The figure below shows an example of a video editing system with a recorder, multiple players, signal output devices, and an editor to control the other devices.

Connect the HD-SDI output of the output devices to the SDI IN connectors of the switcher.



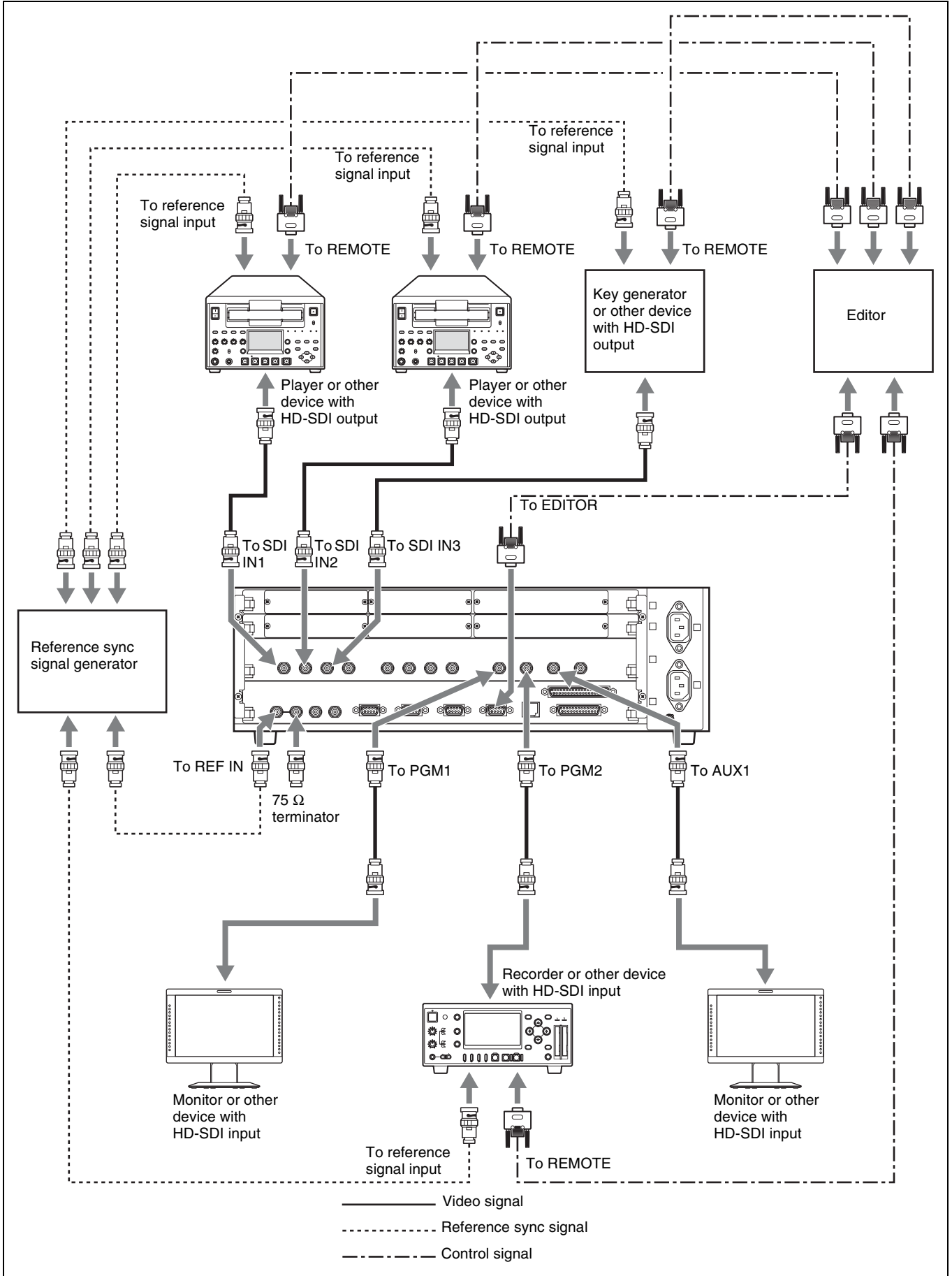

Connection Example 3: Connection to a Device Equipped with a DVI (DVI-I) Connector

You can use the optional BKDF-912 2 DVI Input Board or the optional BKDF-962 2 DVI Output Board to connect the switcher to a computer or other device equipped with a DVI-I connector. The digital signals of the DVI-I connector are compatible with the digital output signals of the HDMI standard, and analog output signals are compatible with the analog signals of the HD15 (high-density 15-pin D-Sub) standard. You can use conversion cables and adaptors to connect them to devices equipped with HDMI or HD15 connectors.

Notes

- When you input video signals from the HDMI connectors to the switcher, the switcher can receive only progressive video signals. The switcher cannot process the video signals copy-protected by HDCP (High-bandwidth Digital Content Protection).
- If you selected “HDTV” for the DVI output signals (*page 94*), color difference component signals (Y/P_b/P_r) are output from the analog signal output connectors of the BKDF-962. For details about the pin assignment of the BKDF-962 connector, *see page 213*.

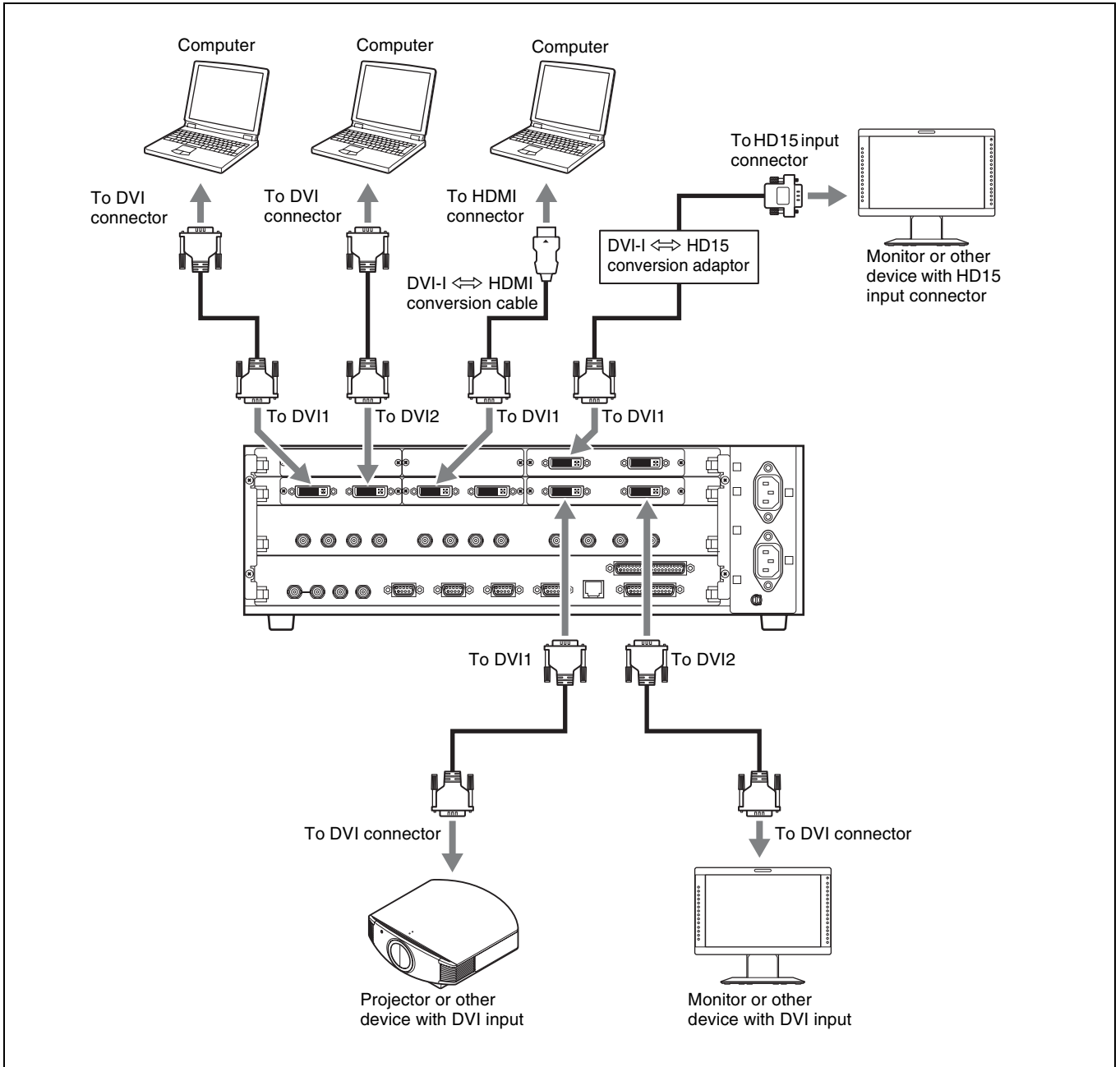

Installing Optional Expansion Boards

This section explains how to install I/O expansion boards, function expansion boards, and the optional power supply unit.

The following expansion options are available. For more information about the various options, *see page 31*.

Type and function of expansion options		Model number
Input expansion boards	4 SDI Input Board	BKDF-910
	2 SD Video Input Board	BKDF-911
	2 DVI Input Board	BKDF-912
Output expansion boards	4 SDI Output Board	BKDF-960
	2 SD Video Output Board	BKDF-961
	2 DVI Output Board	BKDF-962
Function expansion boards	2CH DME Board	BKDF-940
	Multi Viewer Board	BKDF-950
Power supply unit		BKDF-990

Notes

- Always power off all devices before starting the operation for installing or removing expansion options.
- **The processor unit will still be hot immediately after it is powered off. Always wait at least 30 minutes before starting the operation for installing or removing expansion options.**
- Always install expansion options in the designated locations.
- Always install expansion options using the screws supplied with the expansion options. Use of other screws may damage the expansion options or processor unit.
- Be careful to avoid injury when installing and removing expansion options.
- You can use the Status sub menu of the Setup menu to check whether expansion options are installed. For details, *see page 170*.

Installing I/O Expansion Boards

About installation locations and channel numbers

Pull out the expansion board installation trays from the I/O expansion board slots (lower and upper) on the rear panel of the processor unit, use the screws supplied with the boards to secure them to trays, and then return the trays to the slots. Facing the processor unit, install the input expansion boards at the far left and center positions, and install the output expansion boards at the far right position.

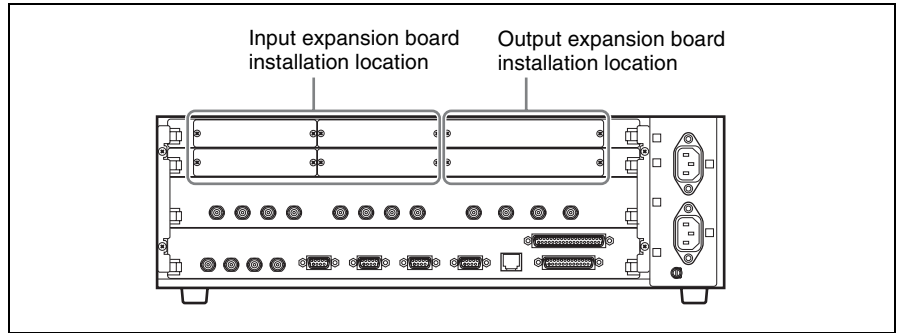

A number is assigned to each of the channels on installed I/O expansion boards (IN09 to IN24 on input expansion boards, and AUX03 to AUX10 on output expansion boards). The following table lists the installation locations of the various boards and the numbers assigned to their channels after installation.

Notes

- Some channel numbers are invalid for some boards.
- The channel display names of I/O expansion boards can be changed to names up to four alphanumeric characters in length. For details, *see page 74*.

Input expansion board channel numbers

		Installation position on expansion board installation tray					
		Lower tray			Upper tray		
		Left	Center	Right	Left	Center	Right
Whether board can be installed		Yes	Yes	No	Yes	Yes	No
Input number display after installation	BKDF-910 4 SDI Input Board	IN09 to IN12	IN13 to IN16	–	IN17 to IN20	IN21 to IN24	–
	BKDF-911 2 SD Video Input Board	IN09 to IN10 ^{a)}	IN13 to IN14 ^{b)}	–	IN17 to IN18 ^{c)}	IN21 to IN22 ^{d)}	–
	BKDF-912 2 DVI Input Board						

- a) IN11 and IN12 are invalid.
 b) IN15 and IN16 are invalid.
 c) IN19 and IN20 are invalid.
 d) IN23 and IN24 are invalid.

Output expansion board channel numbers

		Installation position on expansion board installation tray					
		Lower tray			Upper tray		
		Left	Center	Right	Left	Center	Right
Whether board can be installed		No	No	Yes	No	No	Yes
Output number display after installation	BKDF-960 4 SDI Output Board	–	–	AUX03 to AUX06	–	–	AUX07 to AUX10
	BKDF-961 2 SD Video Output Board	–	–	AUX03 to AUX04 ^{a)}	–	–	AUX07 to AUX08 ^{b)}
	BKDF-962 2 DVI Output Board						

a) AUX05 and AUX06 are invalid.
b) AUX09 and AUX10 are invalid.

To install I/O expansion boards

Use the following procedure to install expansion boards. (The example figures show the lower expansion board tray, but the procedure is the same for the upper tray.)

- 1 Remove the four screws (+B 3×6) securing the board tray stabilizers, and remove the stabilizers.

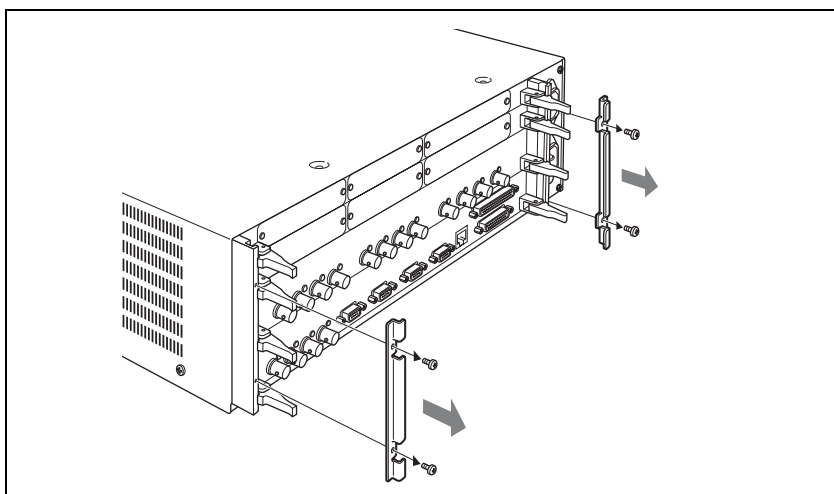

- 2 As shown in the figure below, push the levers on each end of the expansion board installation tray to open them, and then pull the tray out.

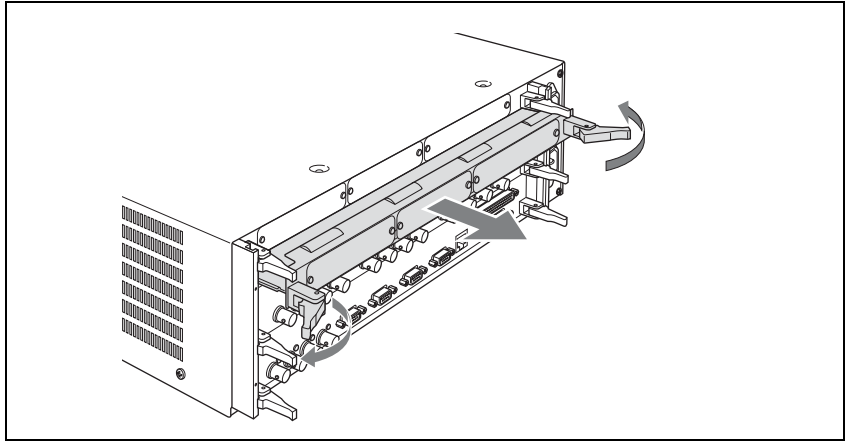

3 Use the following procedure to remove the panels on the expansion board installation tray.

- ① Remove the two screws (+M3) securing the ventilation adjustment panel, and remove the ventilation adjustment panel.
- ② Remove the two screws (+M2.6) securing the blank panel where you want to install an I/O expansion board, and remove the blank panel.

Notes

- Do not discard the panels. Retain them for future use. If you remove an I/O expansion board, you will need to reattach the blank panel. If you remove all I/O expansion boards, reattach the ventilation adjustment panel.
- Use the screws that secured the blank panel to secure the I/O expansion board. For details, see step 5. Keep the screws that secured the ventilation adjustment panel together with the ventilation adjustment panel.

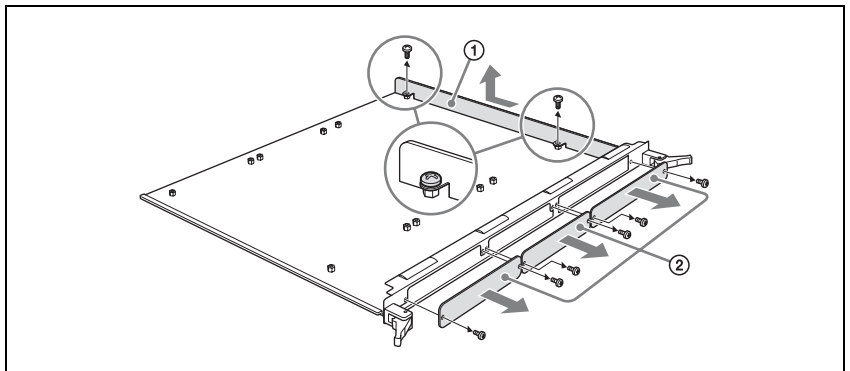

- 4** Use the following procedure to affix the heat transfer sheet (supplied with each I/O expansion board) to the expansion board installation tray.

- ① Remove the adhesive surface cover sheet from one side only of the heat transfer sheet.

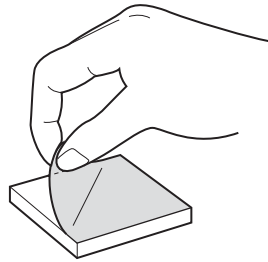

- ② Hold the bottom side of the heat transfer sheet (the side from which you removed the adhesive cover sheet) down and affix it to the expansion board installation tray, aligning it with the positioning guide frame on the expansion board installation tray.

Positioning guide frames
(for input expansion board)

Positioning guide frame
(for output expansion board)

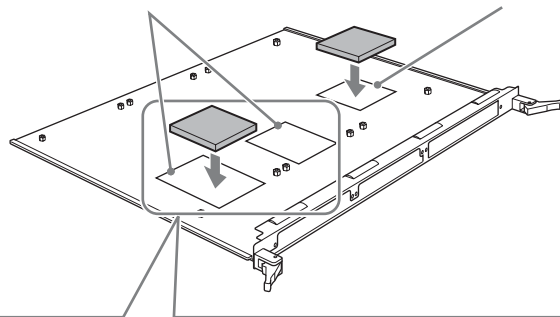

I/O expansion board heat transfer sheet affixation position (shaded part)

BKDF-910

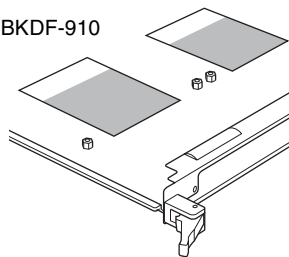

BKDF-911 and
BKDF-912

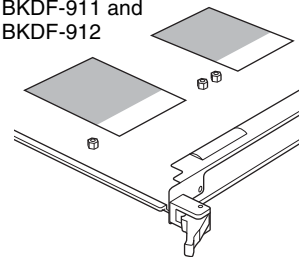

- ③ Remove the adhesive surface cover sheet from the top side of the heat transfer sheet.

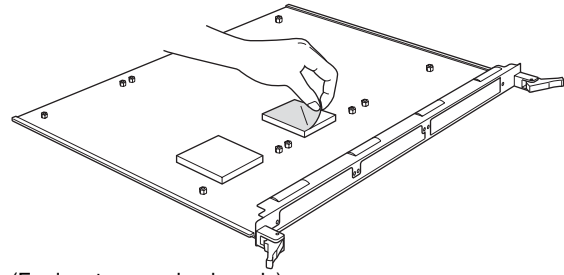

(For input expansion boards)

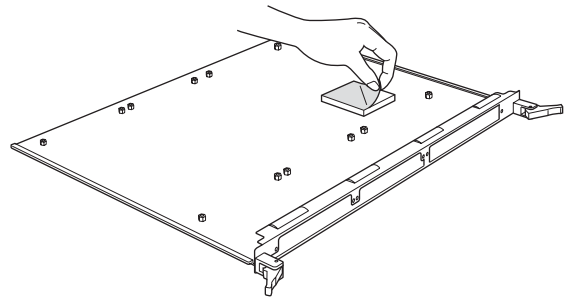

(For output expansion boards)

- 5 Push the connectors of the expansion board through the inner side of the connector name plate frame, place the expansion board on the expansion board installation tray, and secure the board with the supplied four +M3 screws.

Notes

- Use a torque screwdriver to tighten the screws. Set the tightening torque to 0.59 N·m.
- For the installation positions of expansion boards, *see page 39*.

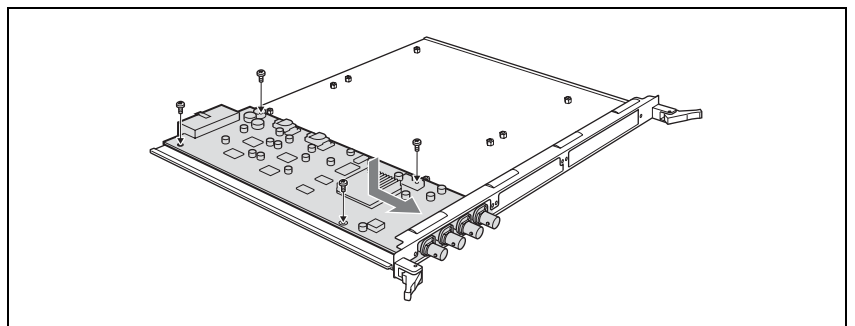

- 6 Use the following procedure to attach the connector name plate supplied with the expansion board.

- ① Using the screws (see the following table) supplied with the expansion board, secure the connector name plate to the expansion board.

Expansion board	Screws	Tightening torque
BKDF-910 BKDF-911 BKDF-960 BKDF-961	+M2.6 × 4	0.49N·m
BKDF-912 BKDF-962	Hexagon head bolt (5mm in width across flats) × 4	0.5N·m

Note

For the BKDF-912 and BKDF-962, use a nut driver to tighten the hexagon head bolt.

- ② Using the two screws removed in step 3, secure the connector name plate to the expansion board installation tray.

Note

Set the tightening torque to 0.49 N·m for step 6-②.

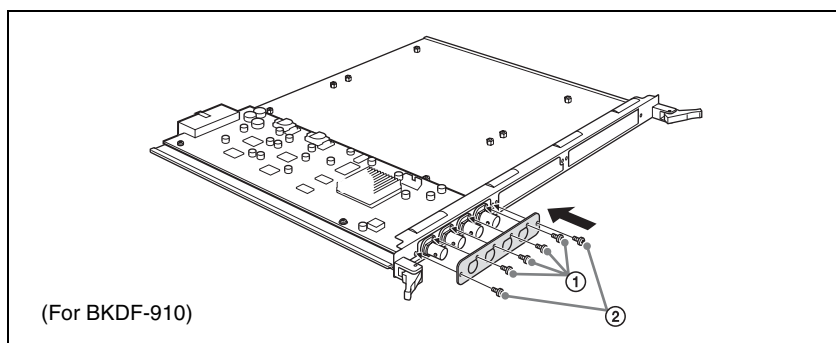

- 7** Insert the expansion board installation tray into its original slot, and align the notches of the levers on both sides of the tray to the left and right sides of the slot mouth.

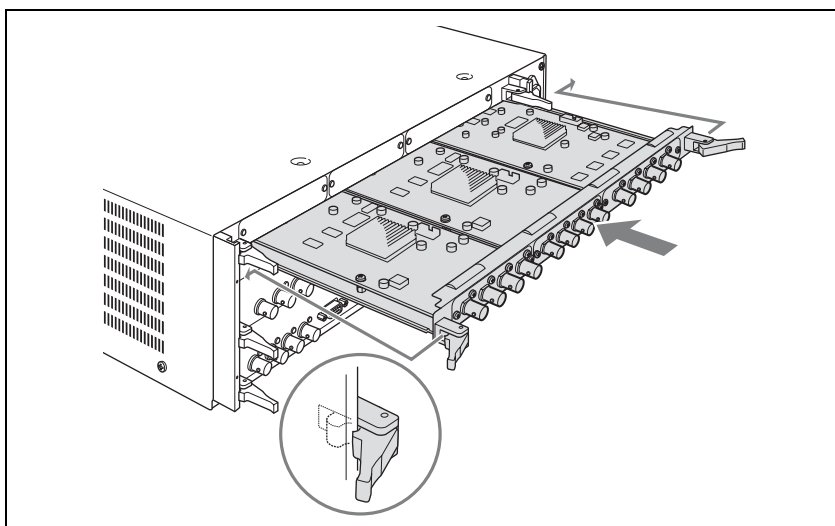

- 8** As shown in the figure below, lock the tray by pulling the tray levers toward the inside.

The tray is pushed all the way into the slot and locked in place.

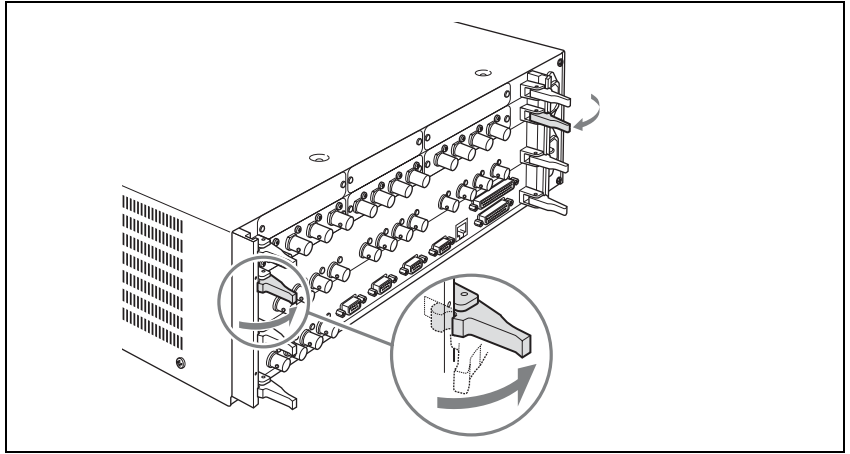

- 9** Using the four screws removed in step 1, attach the board tray stabilizers.

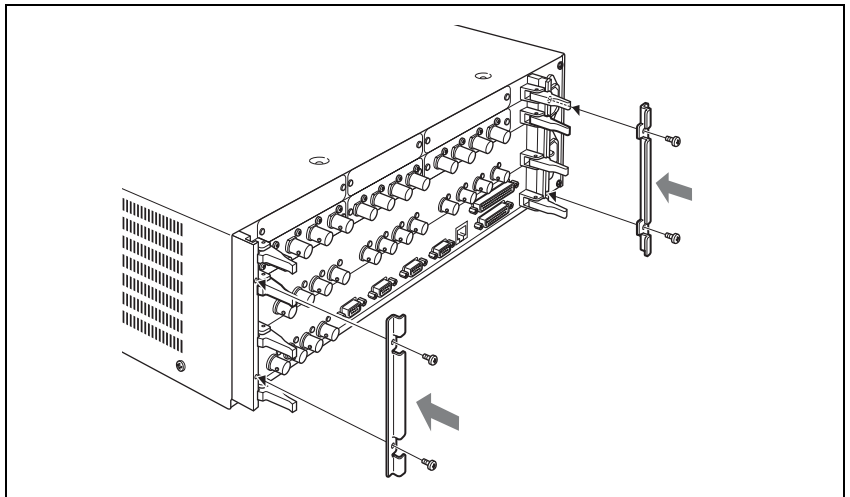

To remove I/O expansion boards

Carry out the installation procedure in reverse.

Installing Function Expansion Boards

About installation locations

Pull the standard I/O module out from the rear panel of the processor unit, and install the function expansion boards on the standard I/O module. Insert the expansion board connectors into the sockets on the standard I/O module and secure them with the screws supplied with the expansion boards. Connect the BKDF-940 to the DME1 and DME2 sockets, and connect the BKDF-950 to the MV1 and MV2 sockets.

Yes: Can be installed No: Cannot be installed

Function expansion board	Socket on standard I/O module			
	DME1 socket	DME2 socket	MV1 socket	MV2 socket
BKDF-940 2CH DME Board	Yes	Yes	No	No
BKDF-950 Multi Viewer Board	No	No	Yes	Yes

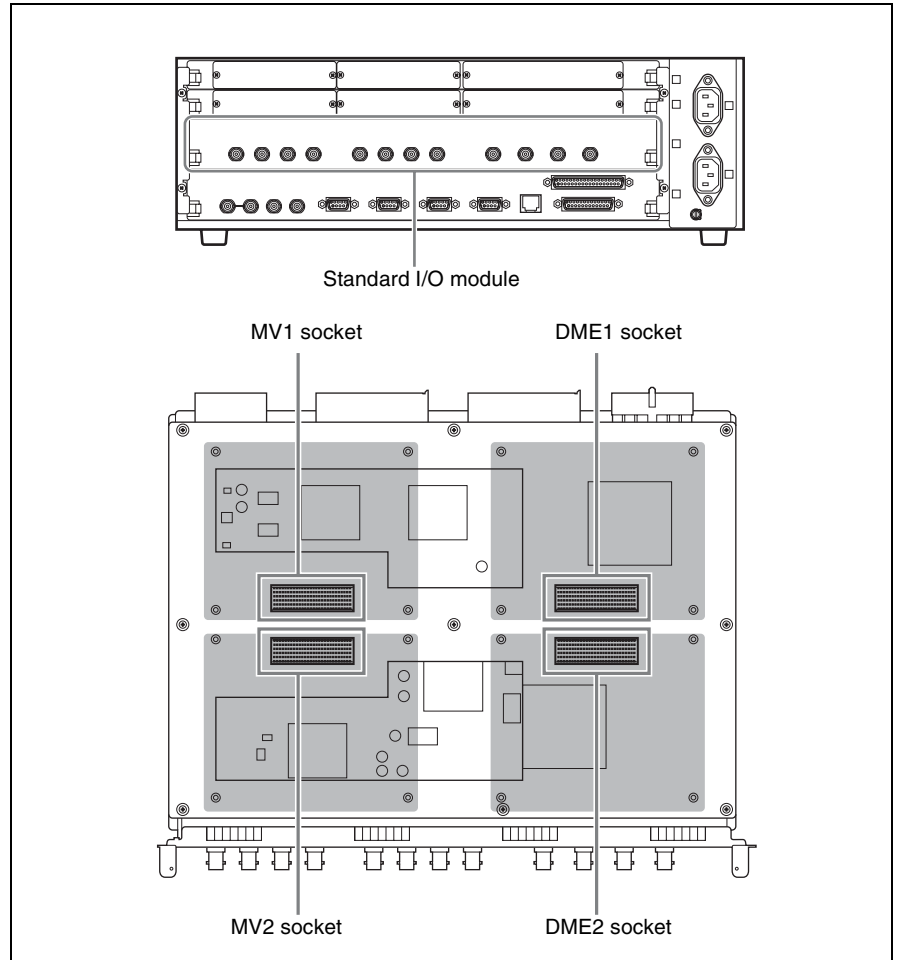

To install function expansion boards

Use the following procedure to install function expansion boards.

- 1 Remove the four screws (+B 3×6) securing the board tray stabilizers, and remove the stabilizers.

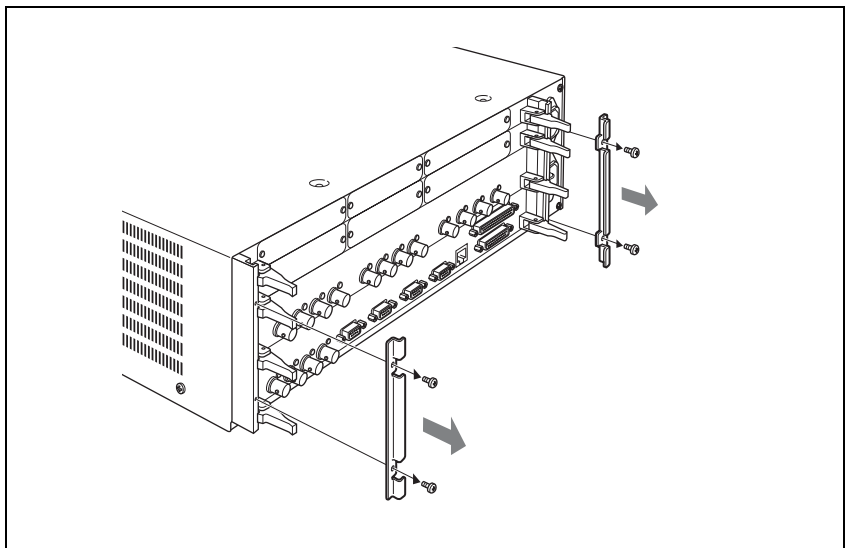

- 2 As shown in the figure below, push the levers on each end of the standard I/O module to open them, and then pull the standard I/O module out.

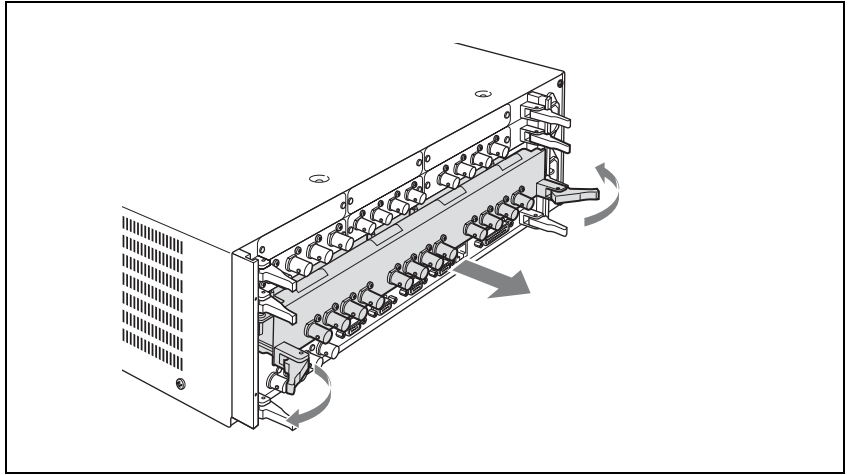

- 3** If you are installing the BKDF-940, proceed as follows to affix the heat transfer sheet supplied with the BKDF-940 to the function expansion board.

- ① Remove the adhesive surface cover sheet from one side only of the heat transfer sheet.

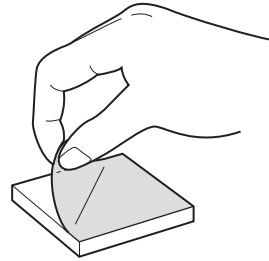

- ② Hold the bottom side of the heat transfer sheet (the side from which you removed the adhesive cover sheet) down and affix it to the standard I/O module, aligning it with the positioning guide frame on the standard I/O module.

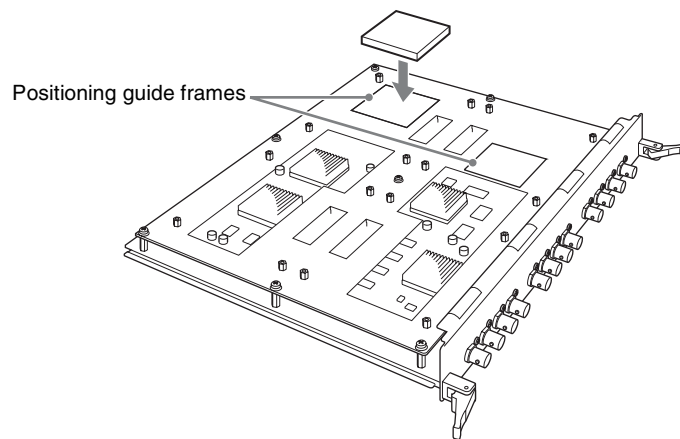

- ③ Remove the adhesive surface cover sheet from the top side of the heat transfer sheet.

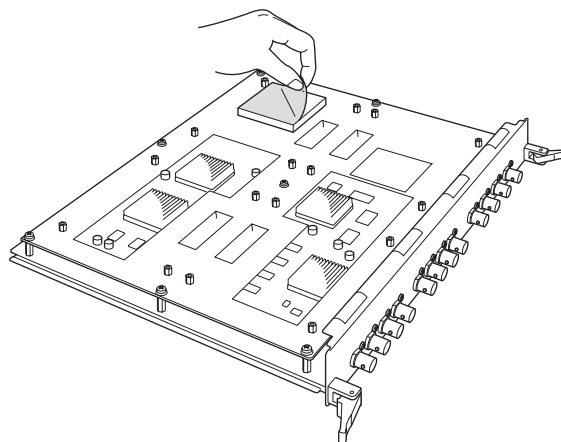

- 4 Align the connectors of the function expansion board with the sockets on the signal processing board of the standard I/O module, grasp the board near the connector, and push the board down until the connector is coupled into the socket.

Note

For the installation location of each expansion board, see *page 46*.

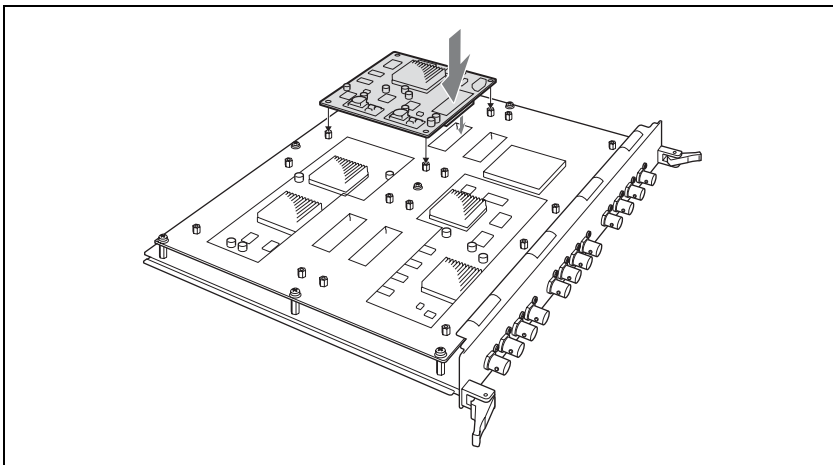

- 5 Using the four +M3 screws supplied with the function expansion board, secure the expansion board to the signal processing board of the standard I/O module.

Note

Use a torque screwdriver to tighten the screws. Set the tightening torque to 0.59 N·m.

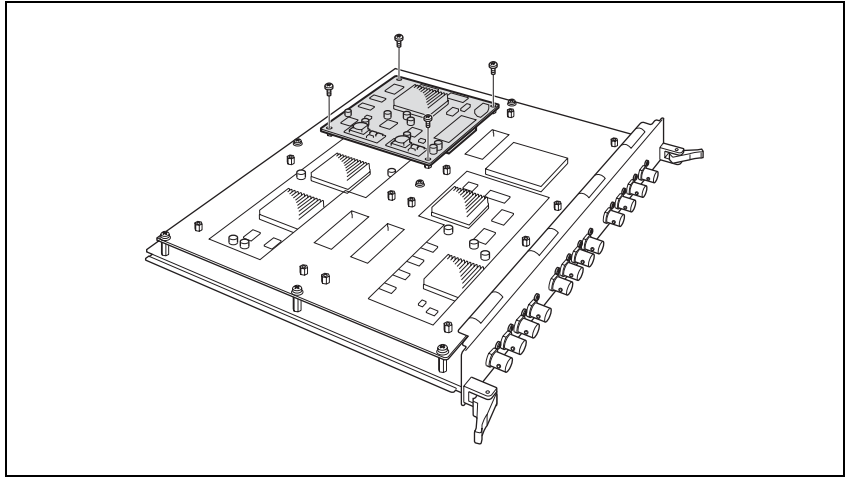

- 6** Insert the standard I/O board into its original slot, and align the notches of the levers on both sides of the board to the left and right sides of the slot mouth.

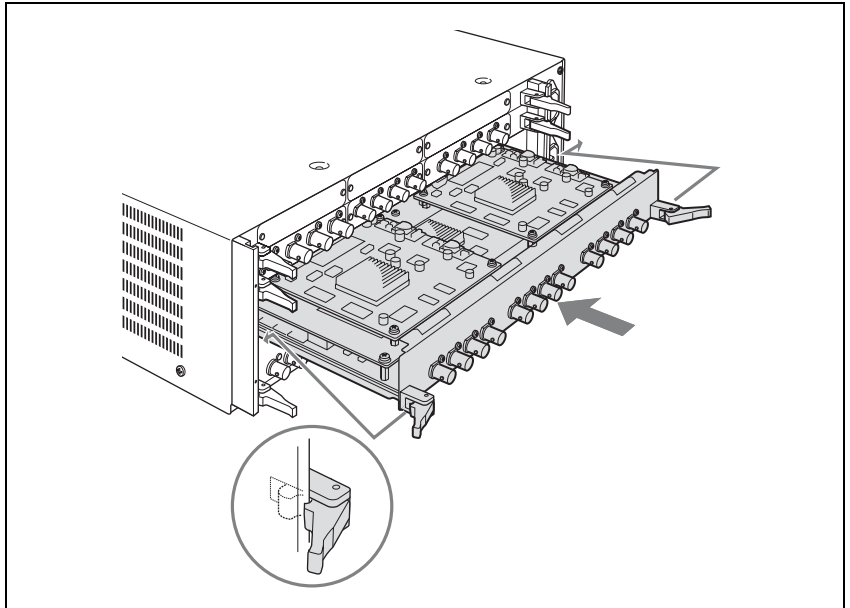

- 7** As shown in the figure below, lock the standard I/O module by pulling the levers toward the inside.

The standard I/O module is pushed all the way into the slot and locked in place.

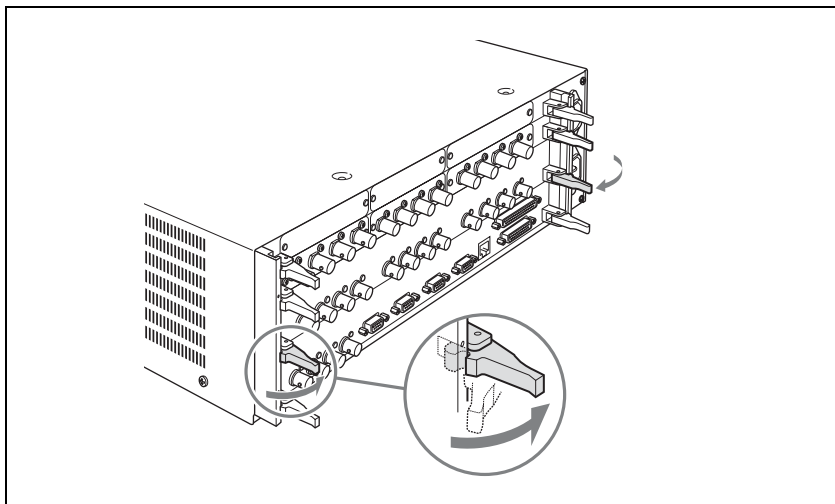

- 8** Using the four screws removed in step **1**, attach the board tray stabilizers.

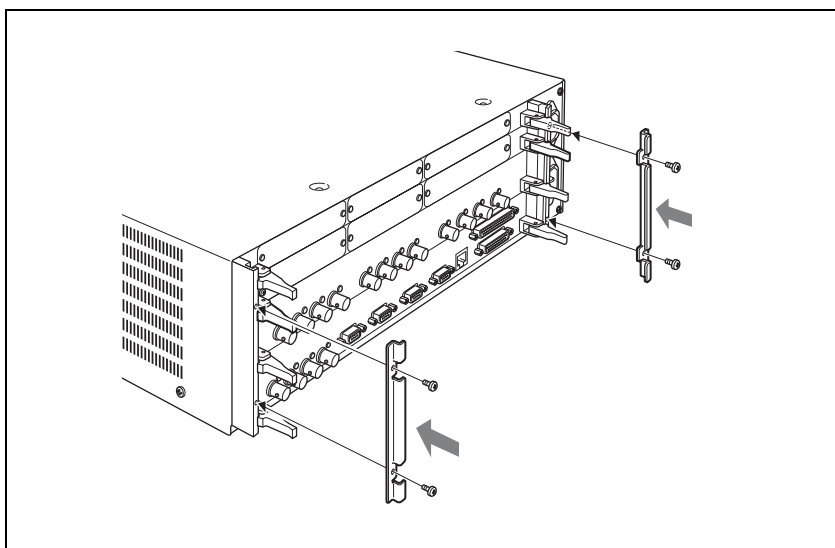

To remove function expansion boards

Carry out the installation procedure in reverse.

Installing the BKDF-990 Power Supply Unit

To install the BKDF-990

Remove the front panel of the processor unit, remove the internal blank panel, and then install the BKDF-990.

- 1** Remove the two screws securing the front panel of the processor unit, and remove the panel.

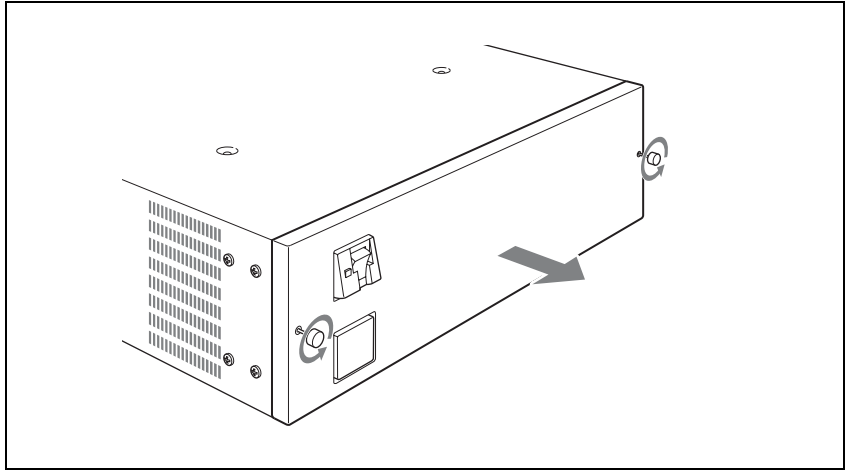

- 2** Remove the two screws (+B 4×8) securing the blank panel inside the processor unit, and remove the blank panel.

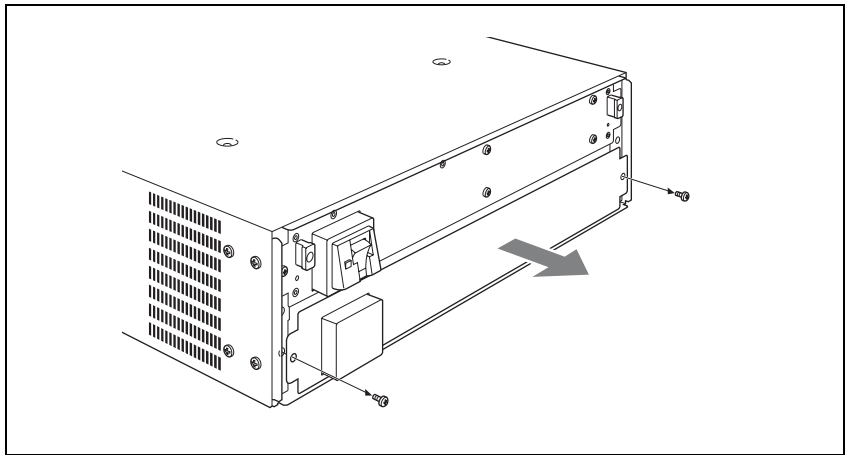

- 3** Insert the BKDF-990 into the installation slot inside the processor unit, and push it all the way in.

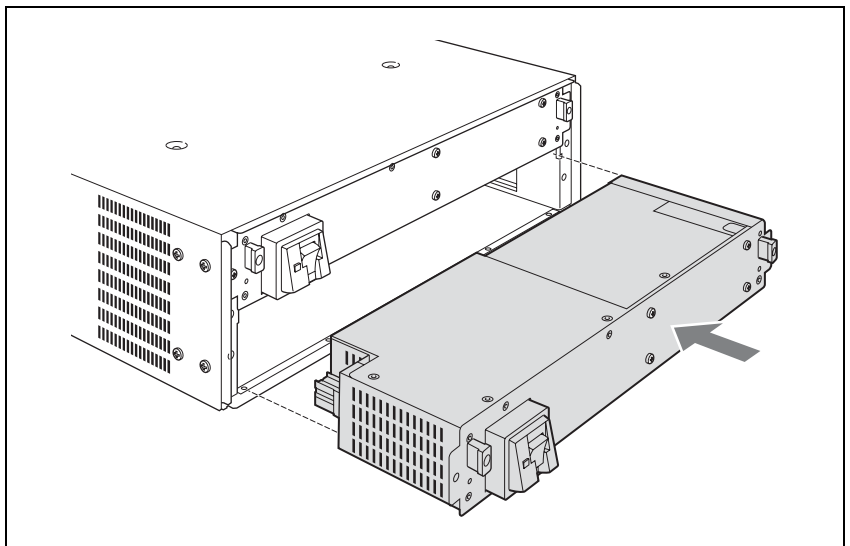

- 4** Using the two screws removed in step **2**, secure the BKDF-990 to the processor unit.

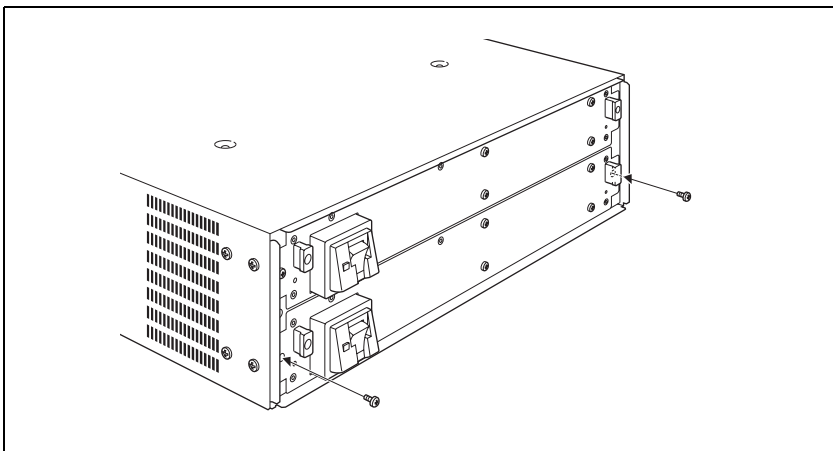

- 5** Using the two screws removed in step 1, attach and secure the front panel.

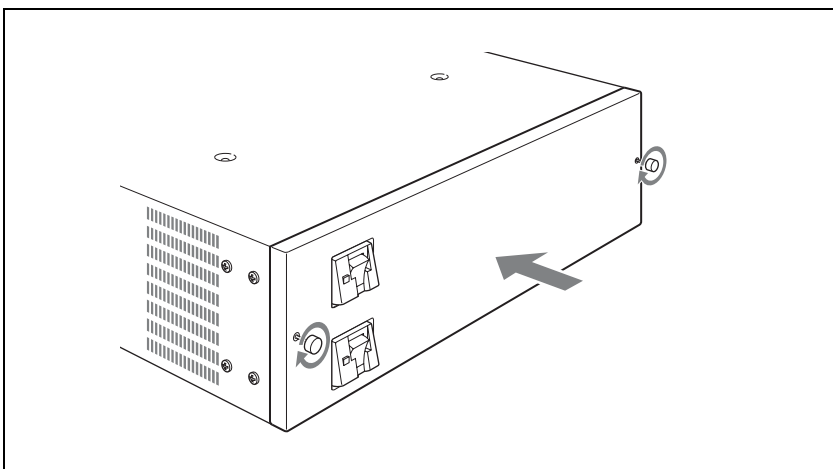

To remove the BKDF-990

Power off the BKDF-990, and then carry out the installation procedure in reverse.

Connecting Up the Switcher

This section explains how to connect up the switcher system.

Changing the Internal Switch Setting in the Processor Unit (When Using the BKDF-902)

When using the BKDF-902, change the setting of a DIP switch on the external device interface connectors board in the processor unit.

Note

When using the BKDF-901, you need not perform the following procedure.

- 1 Remove the four screws (+B 3×6) securing the board tray stabilizers, and remove the stabilizers.

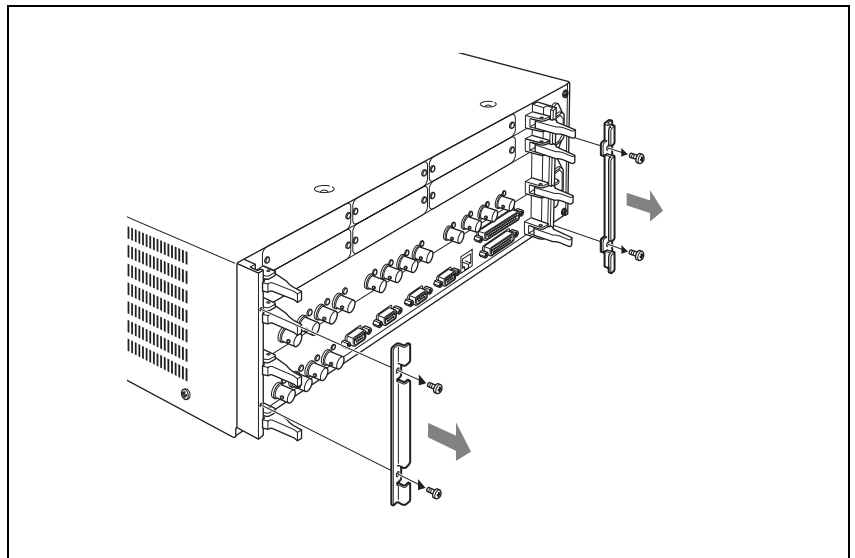

- 2 As shown in the figure below, push the levers on each end of the external device interface connectors board to open them, and then pull the board out.

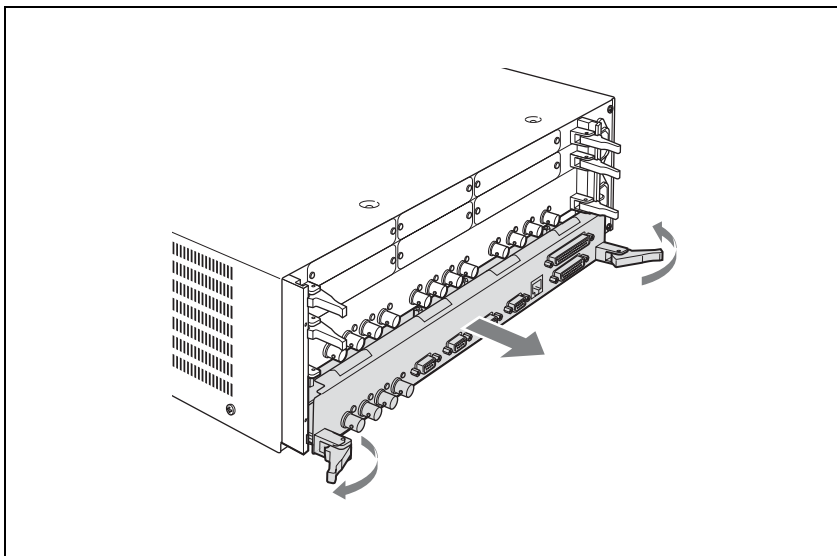

- 3** Set pin 2 of the DIP switch under the flat cable to the “ON” position.

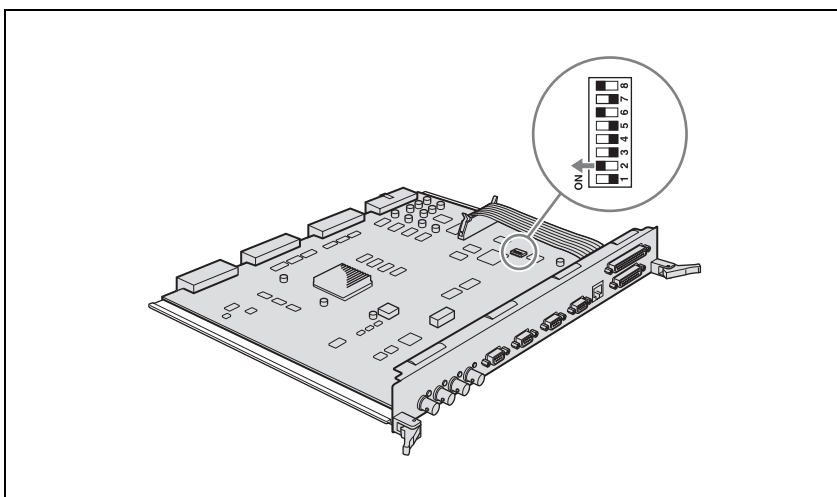

Note

Do not change settings of the other pins.

- 4** Insert the external device interface connectors board into its original slot, and align the notches of the levers on both sides of the board to the left and right sides of the slot mouth.

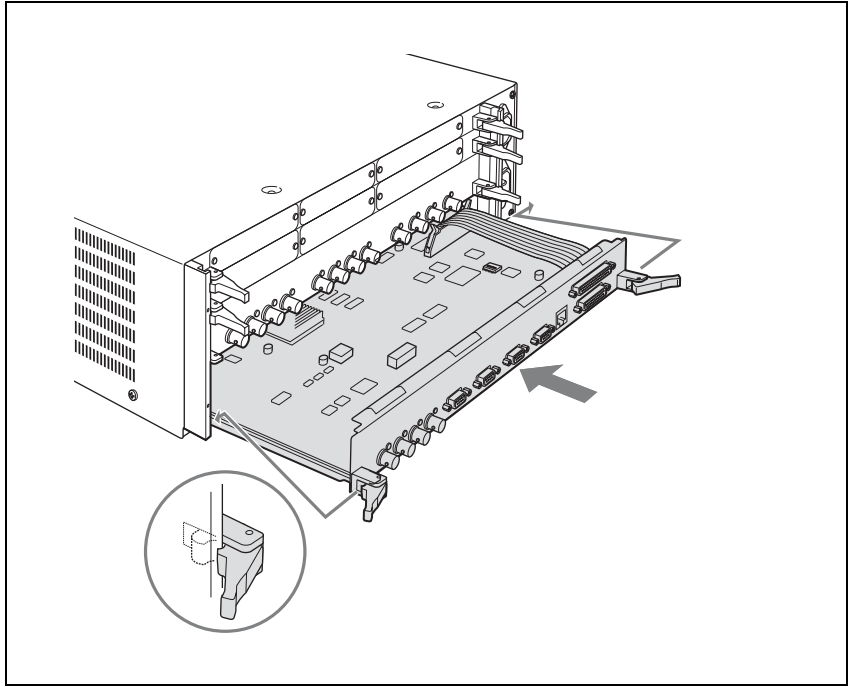

- 5** As shown in the figure below, lock the board by pulling the levers toward the inside.

The board is pushed all the way into the slot and locked in place.

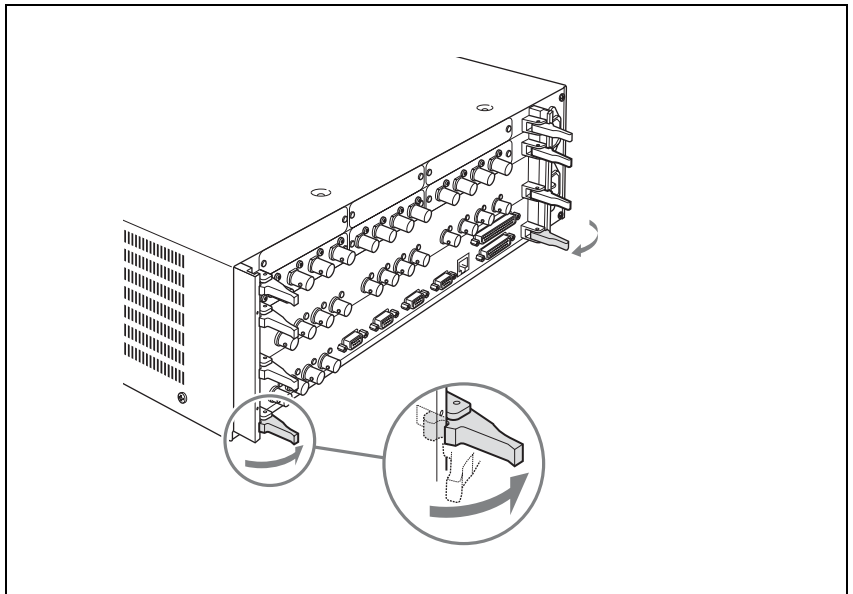

- 6** Using the four screws removed in step **1**, attach the board tray stabilizers.

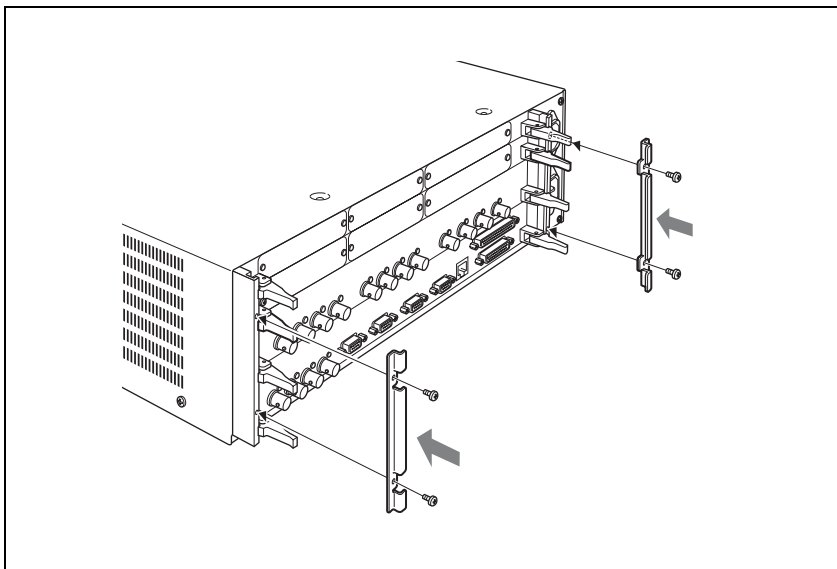

Connecting the Processor Unit and the Control Panel

Using the control cable supplied with the processor unit, connect the PANEL connector of the processor unit and the PROCESSOR connector of the control panel. After connecting the control cable, use two AC power cords (not supplied) to connect the processor unit and the control panel to an AC power source. Note that one more AC power cord is required when the BKDF-990 is installed.

Notes

- Always power off all devices before connecting.
- If you will not be connecting the BKDF-990, connect the AC power cord of the processor unit to the upper \sim AC IN connector.
- If you want to attach the supplied rack mounting bracket to the control panel, refer to the figure on *page 215* for the attachment position. Use the screws supplied with the rack mounting bracket to attach the bracket to the control panel.
- If you want to attach a rack mounting bracket to the processor unit, use the optional RMM-10 Rack Mount Kit. Refer to the *Installation Manual of the RMM-10* for information about how to attach the RMM-10.

When using the BKDF-901

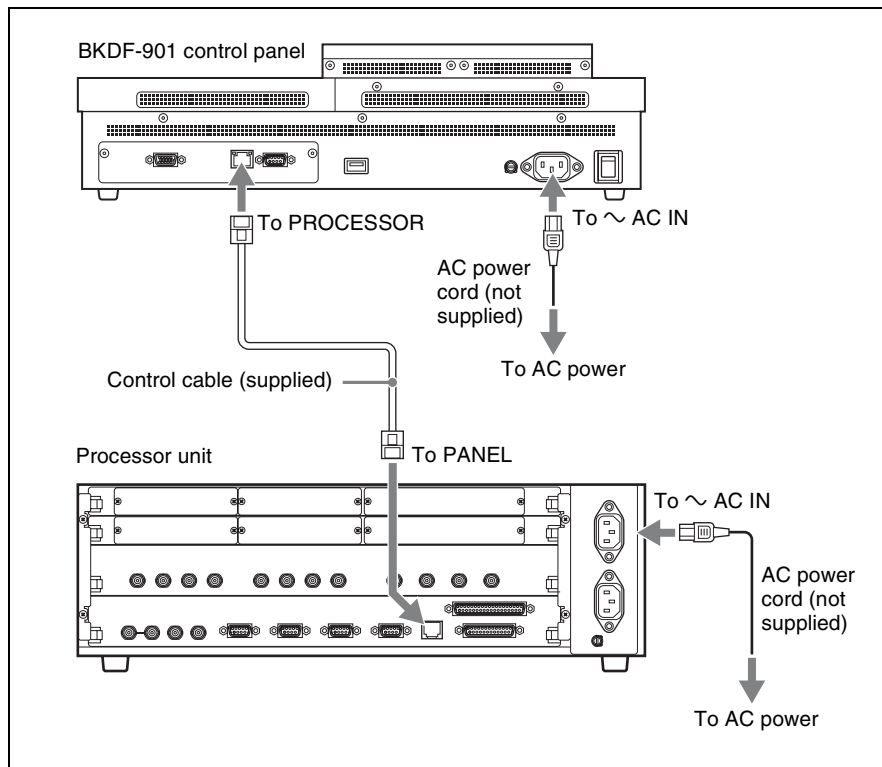

When using the BKDF-902

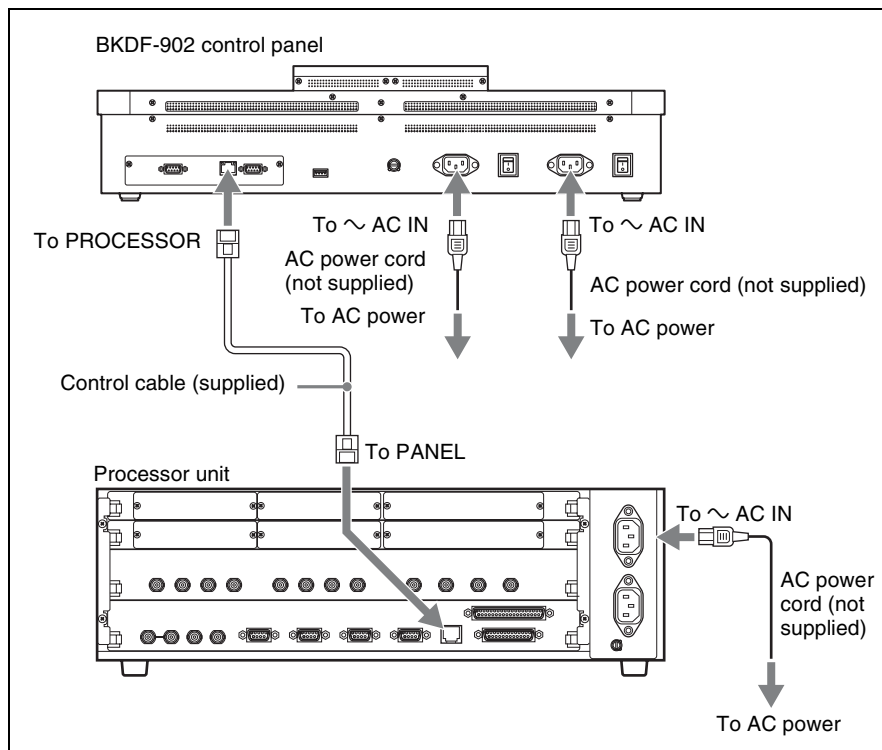

Powering the System On

After connecting up the system, proceed as follows to power it on.

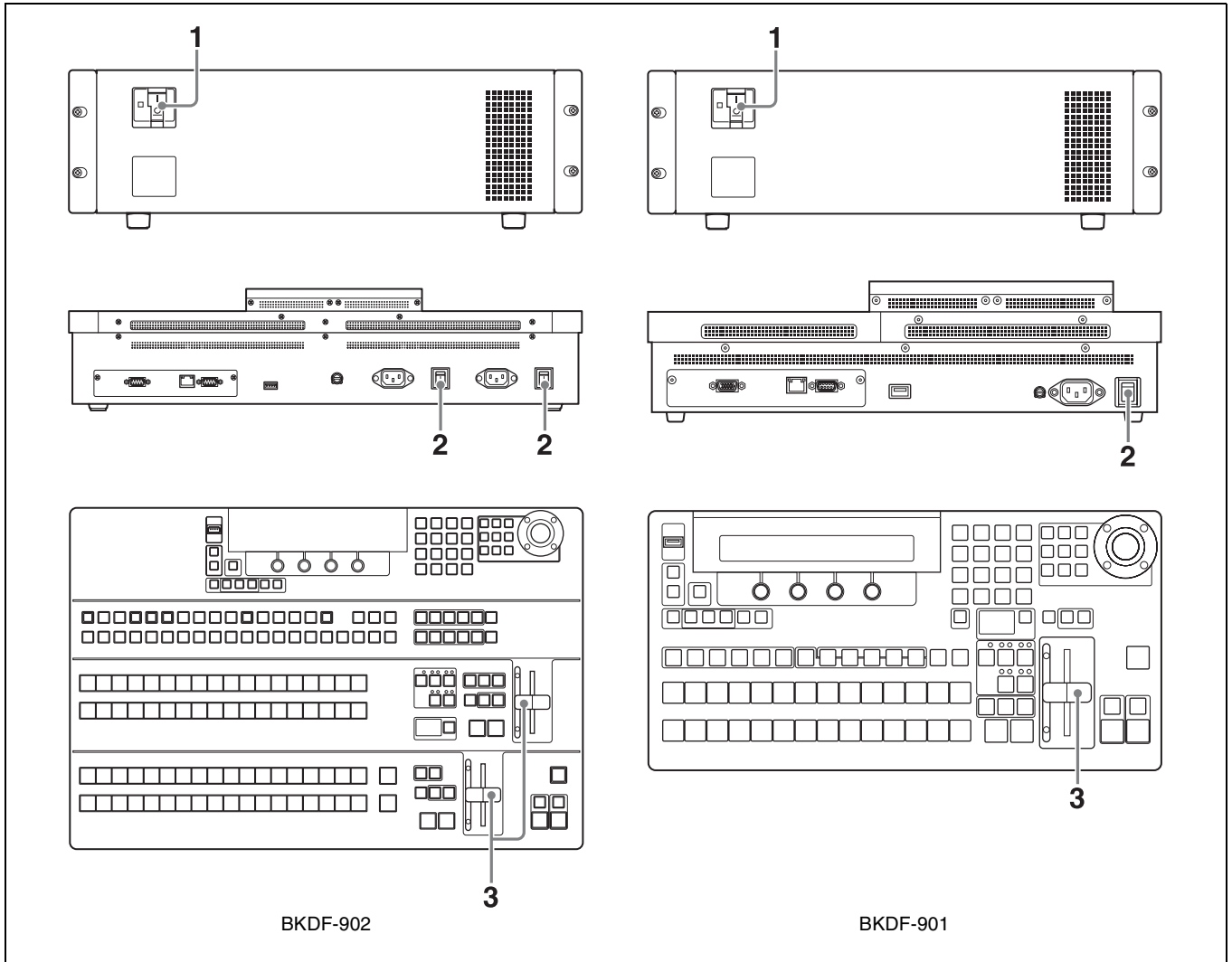

- 1 Turn on the POWER switch on the processor unit by pressing the **I** of the switch.

The processor unit is powered on, and the POWER indicator lights in green.

- 2 Turn on the POWER switch (when using the BKDF-901) or the POWER switches A and B (when using the BKDF-902) on the rear panel of the control panel.

The control panel is powered on, and the panel buttons and display panel light.

The control panel enters boot mode after the power is turned on. Several minutes are required before the control panel can be operated.

When the control panel exits boot mode, the following information appears in the display panel.

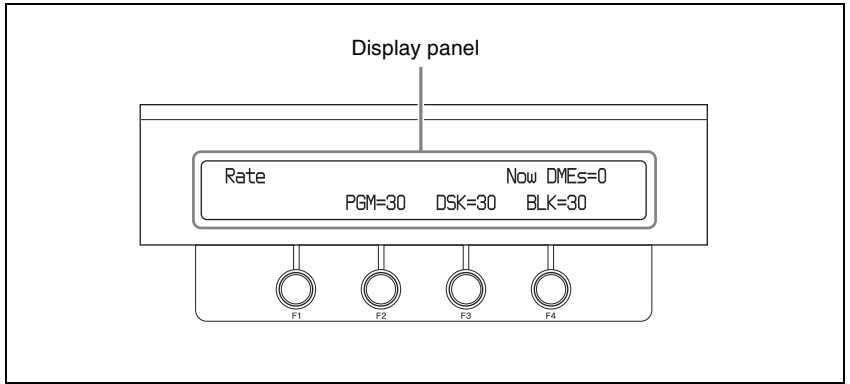

Tip

The following messages appear in the display panel during boot mode.
Now Initializing...Please Wait...: Initializing
Now initial communication started.: Establishing communication between the control panel and the processor unit

- 3** Pull the fader lever once from the top of its range all the way to the bottom.
- 4** Power on the peripheral devices.

To power off

Notes

- Always use the following procedure to power off. If you power off without carrying out the correct procedure, the current control panel settings will not be saved, and the switcher may become unable to boot normally.
- If you have connected a USB flash drive, remove it before powering off.

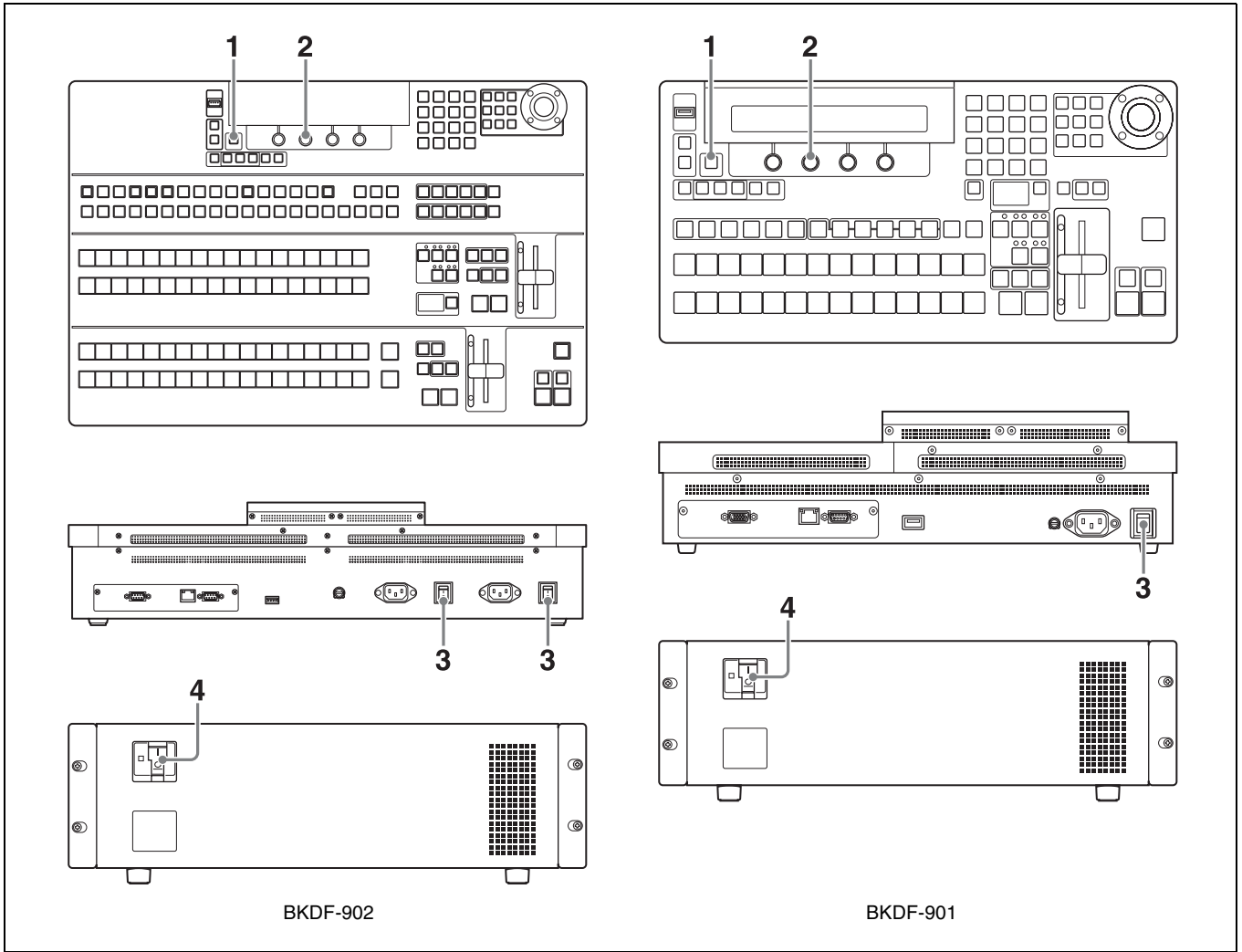

BKDF-902

BKDF-901

1 Press the SHUTDOWN button.

The following message appears in the display panel.

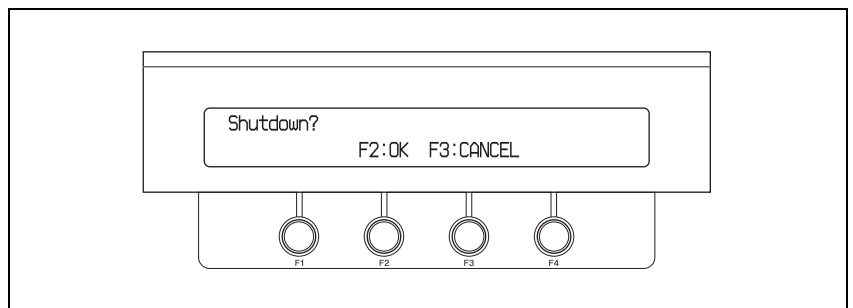

2 Press the F2 knob.

Shutdown processing (storage of the various settings) begins. When storage of the setting ends, the following message appears in the display panel.

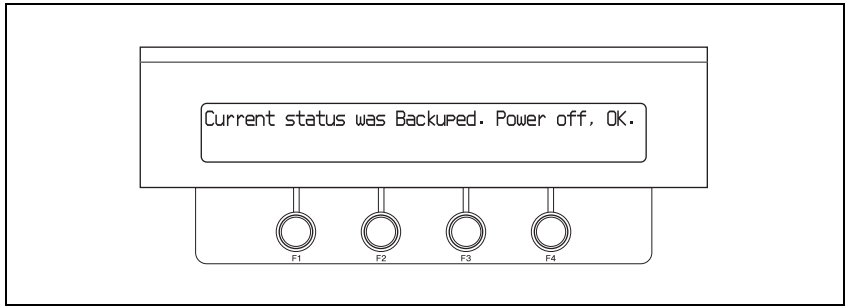

Note

Do not turn off the power switches during shutdown processing. If you turn off the power before the shutdown finishes, the switcher may become unable to boot normally.

- 3** Turn off the POWER switch (when using the BKDF-901) or the POWER switches A and B (when using the BKDF-902) on the rear panel of the control panel.
- 4** Turn off the POWER switch on the processor unit.

Menu Operations

Menus shown in the display panel allow you to make settings for the entire system, select effects, and so on. This section explains the types of menus, the configuration of the menu system, and basic menu operations.

Basic Menu Configuration

The menus of this switcher are divided into the following categories, depending on the type of operation and the setting target.

- **Transition (transition rate, wipe, and DME settings) menu**
Allows you to select and adjust transition rates, wipes, and DME effects.
- **Keyer (key settings) menu**
Allows you to select and adjust transition keys, and the select and adjust DME effects for application to keys.
- **Still Store (still image settings) menu**
Allows you to capture, save, and select still image files to be used for keying.
- **Sequence/Event (sequence and event settings) menu**
Allows you to register combinations of multiple transitions and DME effects, so that the set of transitions and effects can be recalled and used as required.
- **Setup (system settings) menu**
Allows you to make basic system settings, such as video format selection and signal assignments to I/O connectors.

Specific function settings and adjustments are made in the sub menus beneath each menu. Sub menus with many setting items have a hierarchical structure.

For a list of the sub menus beneath each menu, see page 176.

Displaying Menus

When you press a button on the control panel to select a function or perform an operation, a menu related to that function or operation appears in the display panel.

When the menu structure is deep or there are many divisions between setting items, the most recently set sub menu appears. You can press the <<|, >>, <|, and >| buttons on the numeric keypad to move to the sub menu that you want to set.

For details, see the descriptions of the various operations. For a description of the menu and sub menu configuration, see page 176.

Note

You must put the numeric keypad into menu mode before you use the <|, >|, <<|, and >>| buttons to switch between sub menus. For information about how to switch to menu mode, see page 17.

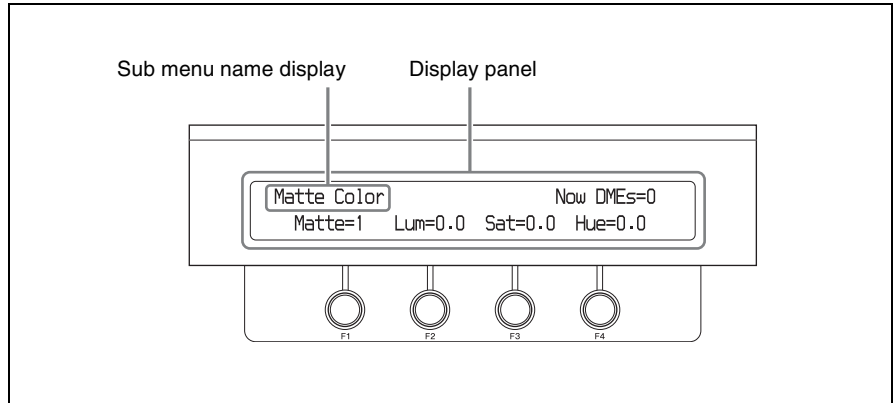

Operating in Menus

Use the F1 to F4 adjustment knobs to change and save settings. Setting names and values appear in the display panel above the corresponding adjustment knobs.

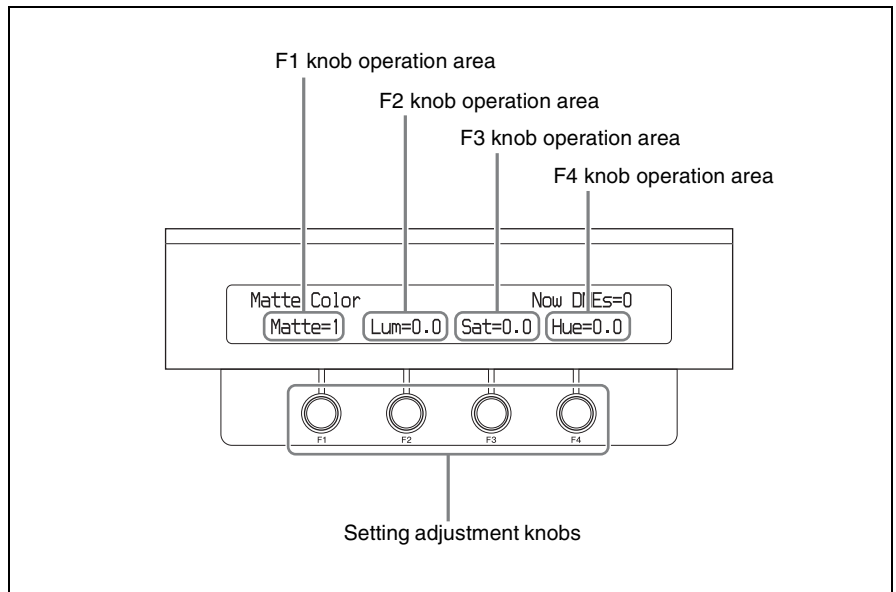

Adjustment knob operations

Basic operations with the adjustment knobs are as follows.

Rotate clockwise: Increase a setting value, or display the next setting item.
Rotate counterclockwise: Decrease a setting value, or display the previous setting item.

Press (when numeric input is required): Enter numeric keypad mode.

Tip

Some knob may return a setting to its factory default value when it is pressed and held for one second or longer.

Menu Operations in the GUI Menus

You can connect a PC monitor and a USB mouse to the switcher. This allows you to select items in menus and sub menus while viewing a GUI menu screen

in the monitor. This can be an aid to smooth operations because it allows you to take in the entire menu system and several menu levels at a glance. Instead of the mouse and monitor, you can also connect a commercially available touch panel monitor. This allows you to select menu items by touching the panel directly.

Connecting devices needed for display and operation

Connecting a PC monitor and USB mouse

Connect the video input connector of the monitor to the EXT.DISPLAY connector on the rear panel of the control panel, and connect a USB mouse to the DEVICE connector on the rear panel of the control panel.

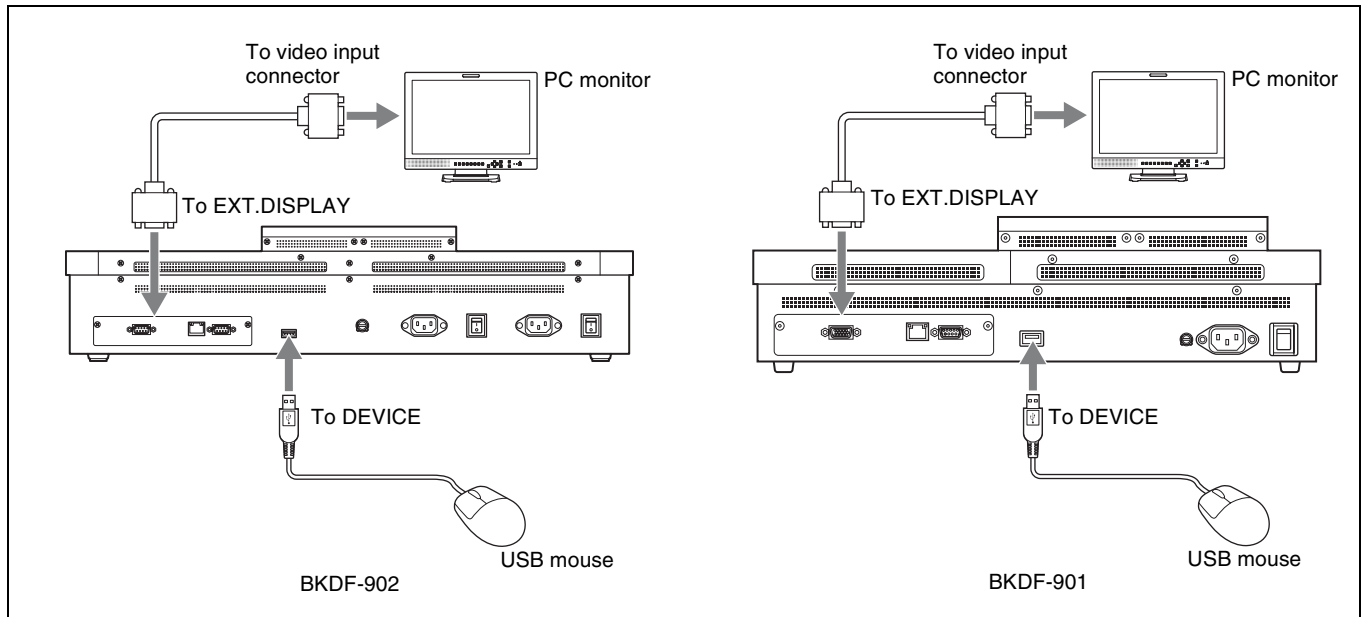

Connecting a touch panel monitor

Connect the video input connector of the monitor to the EXT.DISPLAY connector on the rear panel of the control panel, and connect the USB connector of the monitor to the DEVICE connector on the rear panel of the control panel.

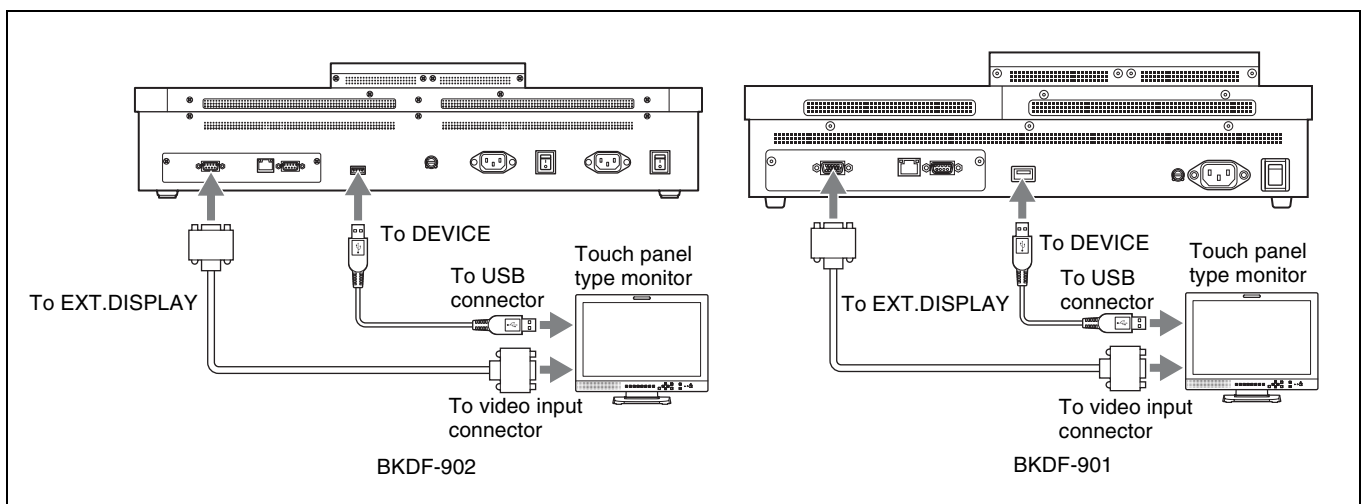

Tip

When selecting a PC monitor or touch panel monitor to connect to this switcher, select one with at least SVGA (800×600) resolution and the ability to adjust the resolution automatically.

To calibrate a touch panel monitor

If you have connected a touch panel monitor, you must calibrate it when you power the switcher on for the first time.

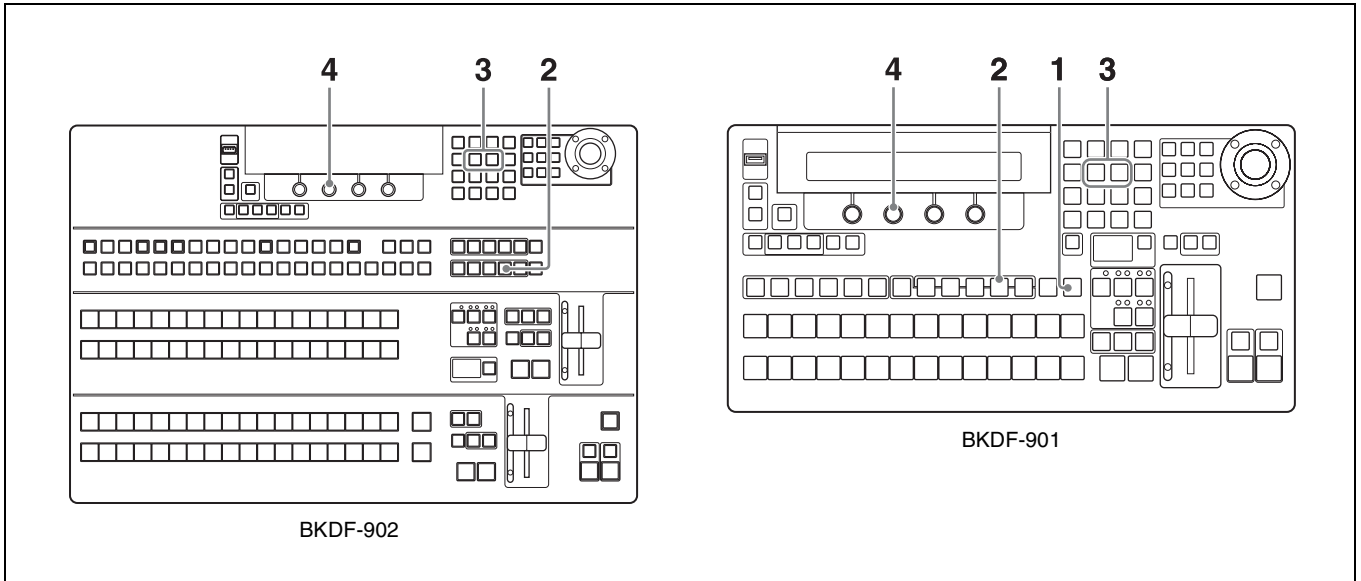

1 When using the **BKDF-901**: If the SHIFT button of the DME/SETUP block is not lit, press it to light it.

When using the **BKDF-902**: Skip to step 2.

2 Press the SYSTEM button.

A settings sub menu of the System sub menu appears in the display panel.

3 Press the ◀ or ▶ button in the numeric keypad until the Update sub menu appears.

“Update” appears in the sub menu title display area. If it is already displayed there, you can skip this step.

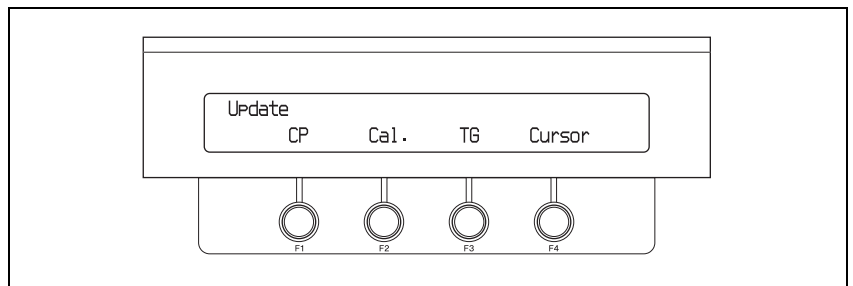

4 Press the F2 knob and hold it down for one second or longer.

A calibration screen appears on the touch panel monitor.

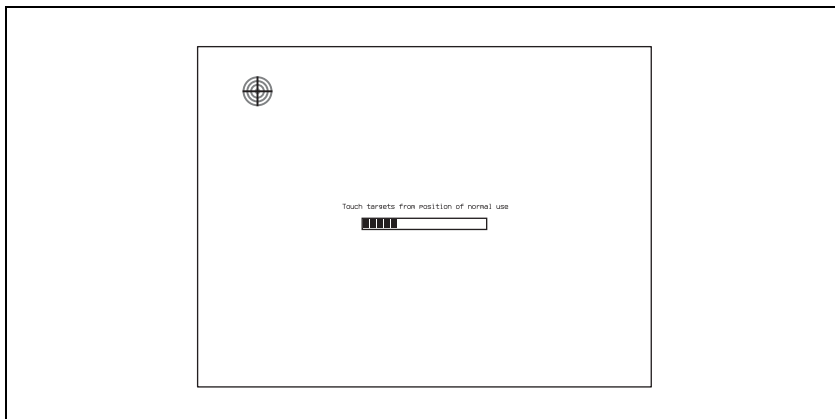

- 5** Press the center point of the calibration mark in the upper left corner of the screen.

The mark disappears when you press it, and another mark appears in the bottom right corner of the screen.

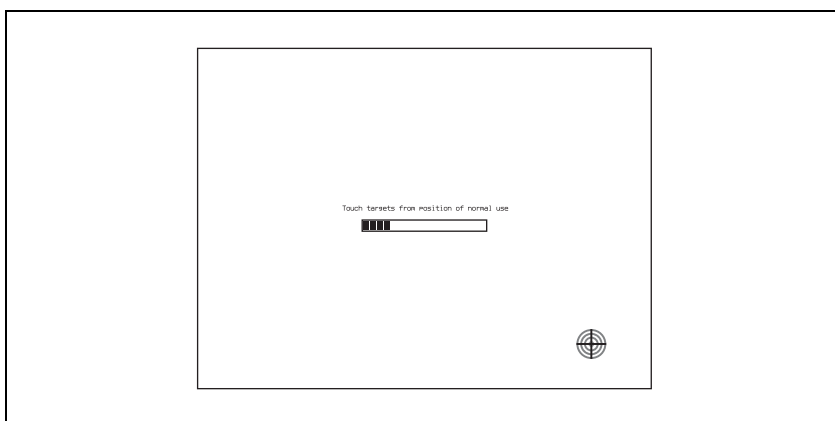

- 6** Press the center point of the calibration mark in the bottom right corner of the screen.

The mark disappears when you press it, and another mark appears in the upper right corner of the screen.

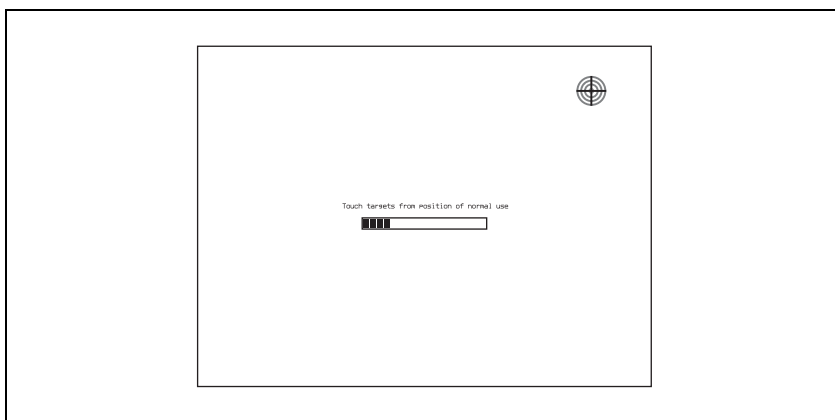

- 7** Press the center point of the calibration mark in the upper right corner of the screen.

A confirmation message appears asking whether you have finished the calibration.

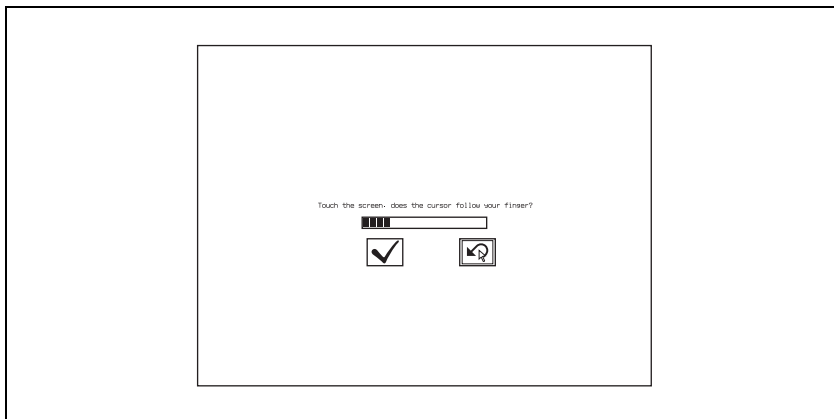

- 8 Press the mark on the screen.

The control panel is powered off and then starts again automatically. The new settings are reflected when it starts again.

Press the mark to return to the calibration screen of step 4.

Note

Calibrate the touch panel monitor again if you notice that a touch position is different from the display position.

GUI menu screen configuration

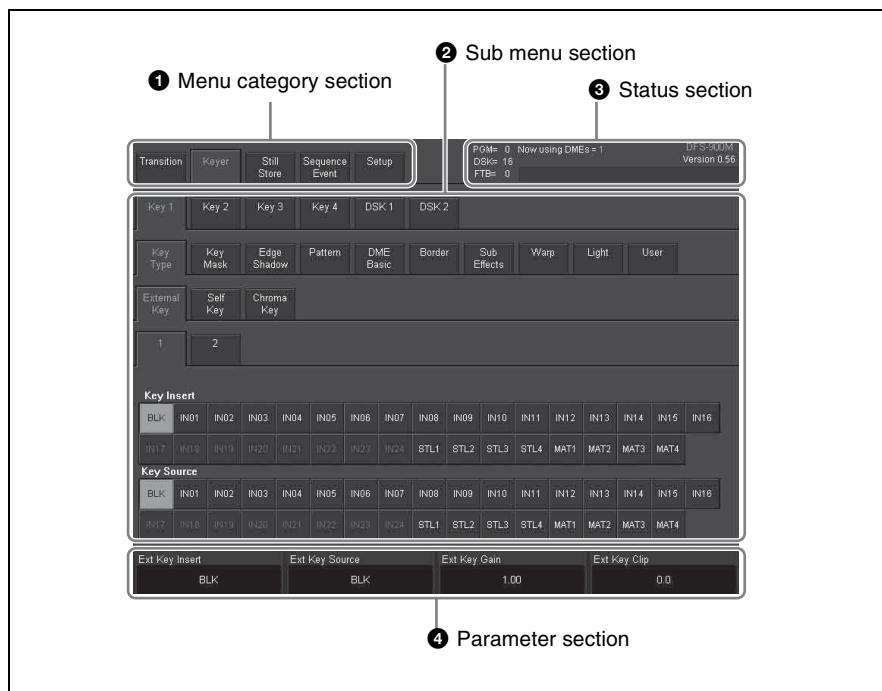

1 Menu category section

Displays tabs (menu selection tabs) for each of the five categories in the basic menu configuration (see page 63). When you select a tab, the sub menus for that menu appear in the sub menu section 2.

2 Sub menu section

Displays tabs for the sub menus in the menu that was selected in the menu category section 1.

3 Status section

Displays the number of DME channels in use, the transition rate, and other status information.

4 Parameter section

Displays the current settings of the current sub menu.

Basic operations in the GUI menu screens

To select menu and sub menu items

If you have connected a PC monitor and a USB mouse, move the cursor to the menu or sub menu item that you want to set, and then left click the mouse. If you have connected a touch panel monitor, you can select a menu or sub menu item by touching the item directly.

To make sub menu settings

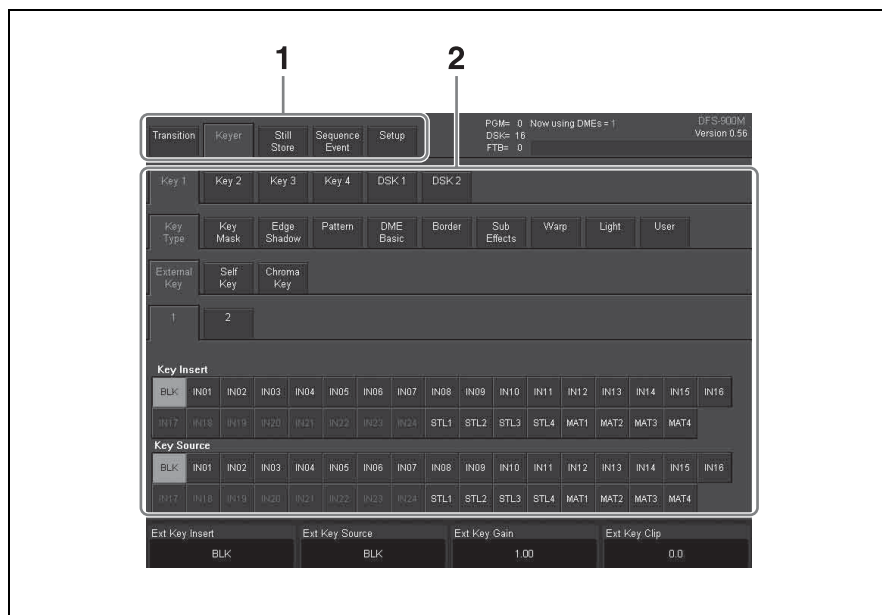

1 In the menu category section, select a menu tab.

Tabs for the sub menus in that menu appear in the sub menu section.

2 Select the tab of the sub menu that you want to set.

The sub menu is selected, and its current settings appear in the parameter section. If the sub menu has a number of levels, you can display the settings for a deeper sub menu by touching its tab, which appears beneath the settings for the current sub menu.

3 Use the F1 to F4 knobs on the control panel to set parameter values.

The figure below shows the correspondence between knobs and menu displays. The procedures for operating in the menus and setting parameters are the same as those for normal menus. For details, see “*Operating in Menus*” (page 64).

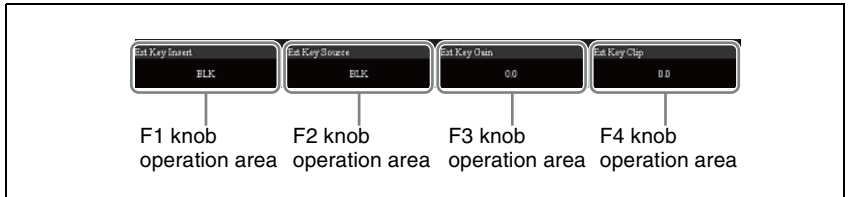

Note

The names of menus and sub menus in the GUI menu screens differ from the names that appear in the display panel of the control panel. See *page 176* for a list of menus and their names as they appear in GUI menu screens and the display panel.



Basic Switcher Settings

This section explains how to make settings that must be made before you can operate the switcher, such as the video format, the selection of I/O channels, etc.

Setting the Video Format

Use the following procedure to set the format of the video signals handled by the switcher.

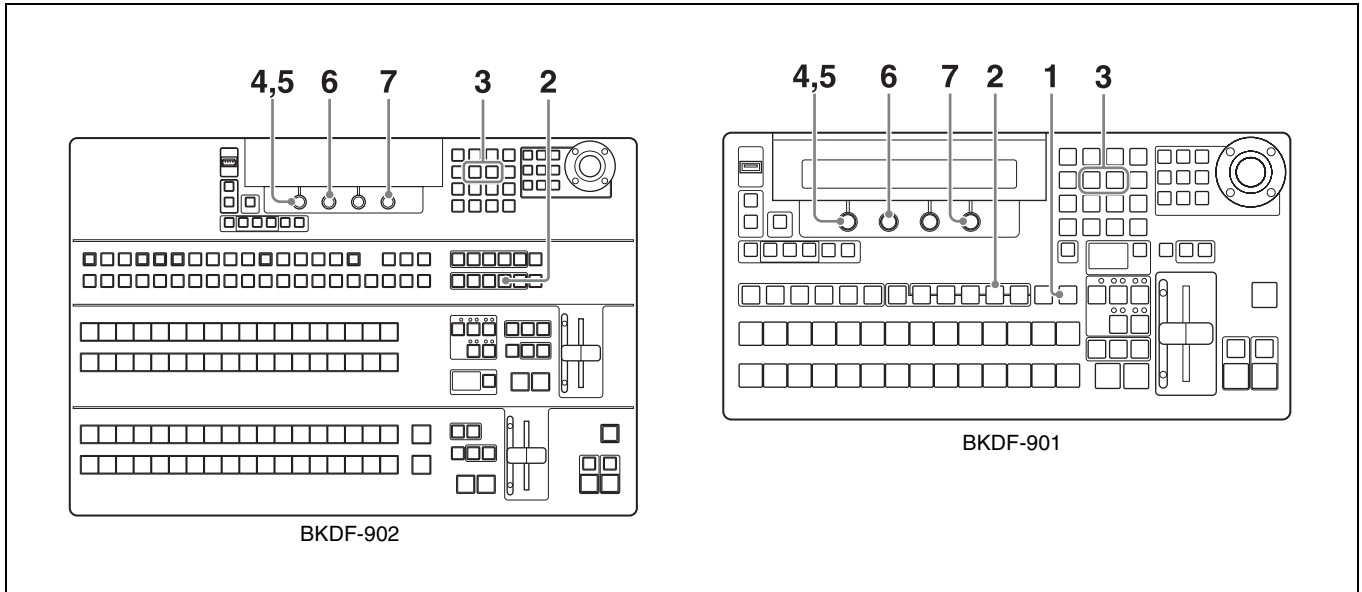

- 1** When using the **BKDF-901**: If the SHIFT button of the DME/SETUP block is not lit, press it to light it.
When using the **BKDF-902**: Skip to step 2.
- 2** Press the SYSTEM button.
A settings sub menu of the System sub menu appears in the display panel.
- 3** Press the ◀ or ▶ button in the numeric keypad until the Type (video format selection) sub menu appears.
“Type” appears in the sub menu title display area. If it is already displayed there, you can skip this step.

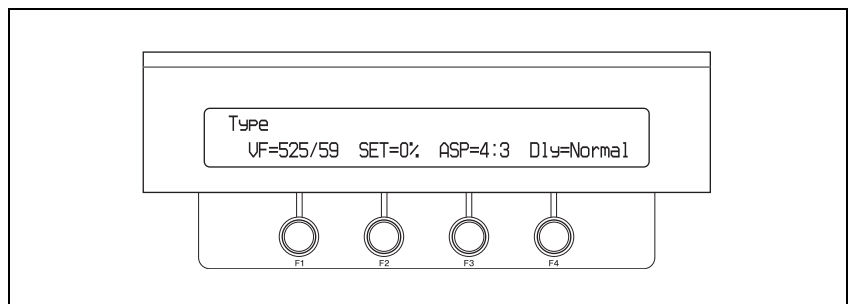

- 4** Rotate the F1 knob to select the video format.

- 525/59:** SD signal (NTSC)
- 625/50:** SD signal (PAL)
- 720/50:** HD signal (720p/50 Hz)
- 720/59:** HD signal (720p/59.94 Hz)
- 1080/50:** HD signal (1080i/50 Hz)
- 1080/59:** HD signal (1080i/59.94 Hz)

Note

Settings values are highlighted if they are different from the current setting value.

- 5** Hold the F1 knob down for one second or longer.

A message appears to confirm the selection of the video format.

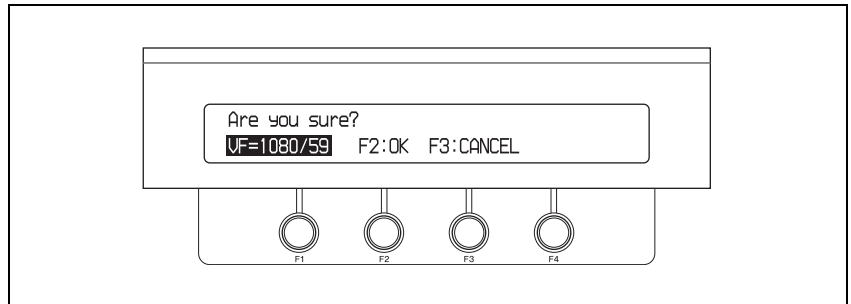

- 6** Press the F2 knob.

The video format selected in step **3** is confirmed.

To cancel the selection, press the F3 knob. This returns to the video format selection screen of step **3**.

Note

When you have changed the video format, you need to restart the switcher. On how to power the switcher off, see “To power off” (page 60).

- 7** Rotate the F4 knob to set the system delay.

Normal: The frame synchronizers for the input connectors (see page 79) are enabled automatically.

Min (Minimum): System delay is held to the minimum. If the frame synchronizers for the input connectors are disabled, the delay with respect to the reference sync signal is 1H.

Tip

The amount of system delay varies depending on DME and frame synchronizer usage.

- 8** Restart the switcher.

Settings when an SD format (525/59 or 625/50) is selected

When an SD format is selected in steps **3** to **6**, set the black setup level (SET) with the F2 knob (for 525/59 only), and set the aspect (SD ASPECT) with the F3 knob.

The selection items and what they select are as follows.

F2 knob (SET) setting

0.0%: Set the black setup level to 0%.

7.5%: Set the black setup level to 7.5%.

F3 knob (SD ASPECT) setting

4: 3: Video with aspect ratio of 4: 3

SQ: Squeeze video

Note

If you have connected a black burst signal to the REF IN connector of the switcher, and SET is set to 7.5%, then a 7.5% setup level is added to the black burst signals (both SD and HD) output from the REF OUT connector.

Making Input and Output Reference Sync Signal Settings

Use the following procedure to specify a reference sync signal input to the switcher, and a reference sync signal generated and output by the switcher.

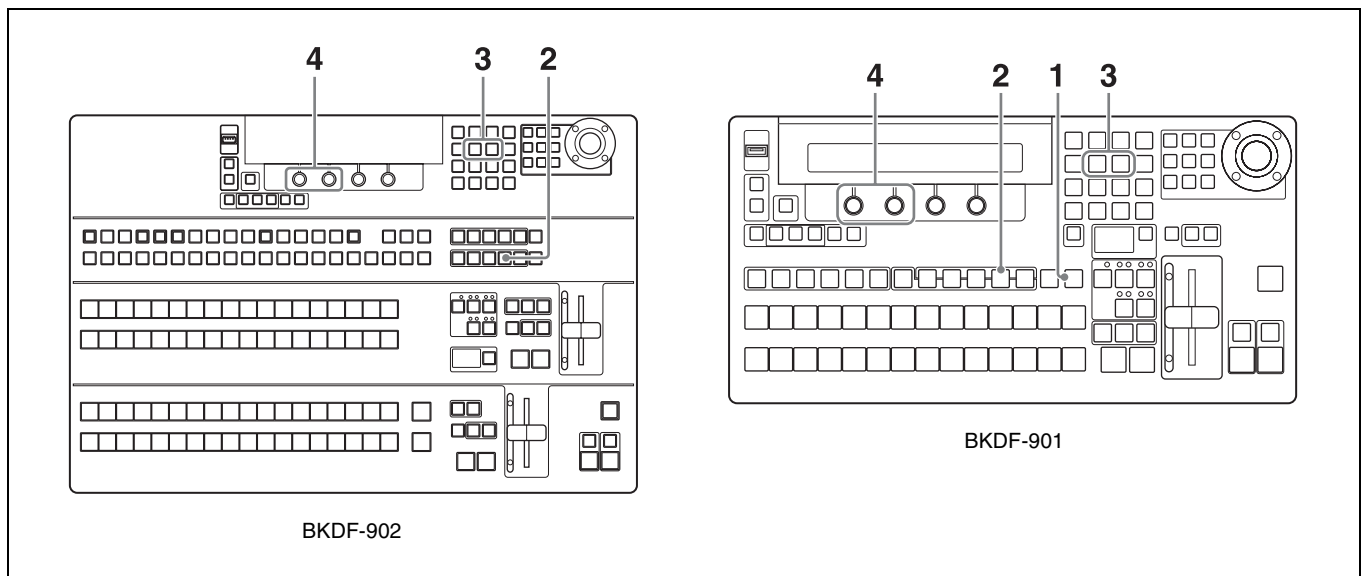

- 1** **When using the BKDF-901:** If the SHIFT button of the DME/SETUP block is not lit, press it to light it.
When using the BKDF-902: Skip to step 2.
- 2** Press the SYSTEM button.
A settings sub menu of the System sub menu appears in the display panel.
- 3** Press the ◀ or ▶ button in the numeric keypad until the Ref (reference sync signal settings) sub menu appears.
“Ref” appears in the sub menu title display area. If it is already displayed there, you can skip this step.

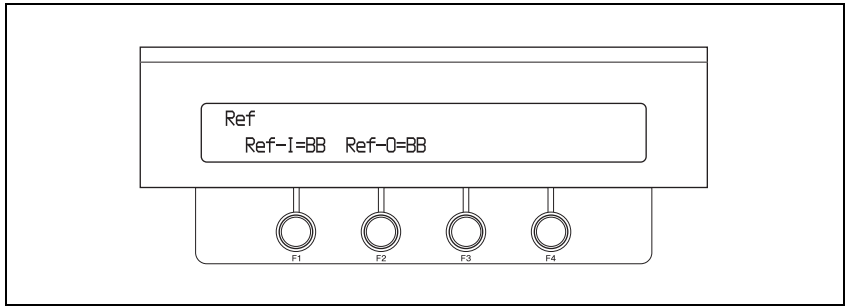

4 Make the reference sync signal settings.

Rotate the F1 knob to specify an input sync signal, and rotate the F2 knob to specify an output sync signal.

The correspondence between knobs and parameters is as follows.

Knob	Parameter	Description	Setting range
F1	Ref-I	Input reference sync signal	BB: Black burst signal TriS: Tri-level sync signal ^{a)}
F2	Ref-O	Output reference sync signal	BB: Black burst signal TriS: Tri-level sync signal ^{a)}

a) Selectable only when the video format is set to an HD signal (720/50, 720/59, 1080/50, 1080/59) (see page 71).

Note

When the video format is set to 1080/59 or 525/59, and you set Ref-O to BB, the setting of Set (see page 71) in the System >Type sub menu is also reflected in the reference sync signal.

Making Settings Related to Input Signals

Changing signal display names

You can change the input signal names displayed in menus to user-specified names up to four alphanumeric characters long.

To change the names, save a text file containing a list of the current signal names to a USB flash drive, edit the names on a computer, and then load the edited list into the switcher.

Tip

Signals have the following display names when the switcher is shipped from the factory.

Signal name	Signal
BLK	Black signal
IN01 to IN08 (numbers are channel numbers)	Input signals connected to the SDI IN 1 to 8 connectors
IN09 to IN24 (numbers are channel numbers)	Input signals connected to optional input expansion boards, when the optional boards are installed
STL1 to STL4	Still images stored in the processor unit
MAT1 to MAT4	Color matte signals for use in backgrounds, etc.

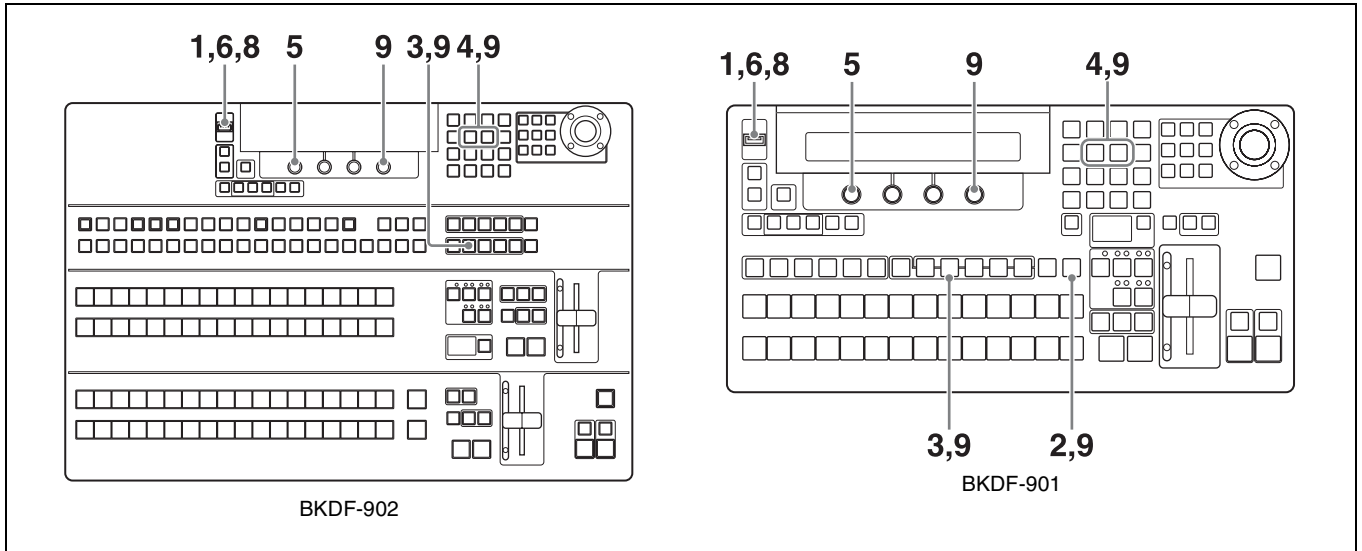

- 1** Insert a USB flash drive into the USB MEMORY connector.
- 2** **When using the BKDF-901:** If the SHIFT button of the DME/SETUP block is not lit, press it to light it.
When using the BKDF-902: Skip to step **3**.
- 3** Press the INPUT button.
A settings sub menu of the Input (input signal settings) sub menu appears in the display panel.
- 4** Press the ◀ or ▶ button in the numeric keypad until the Signal Rename sub menu appears.
“Signal Rename” appears in the sub menu title display area. If it is already displayed there, you can skip this step.

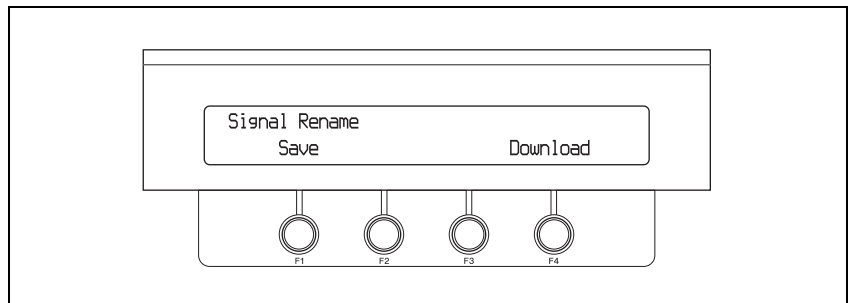

- 5** Hold the F1 knob down for one second or longer.
A file containing a list of the signal names (dfs900.ini) is saved in the root directory of the USB flash drive.
The file is a text file, with content in the following format.

```
[InputShot]
Black = BLK
Input01 = In01
Input02 = In02
Input03 = In03
Input04 = In04
Input05 = In05
```

- 6 Remove the USB flash drive from the USB MEMORY connector, and load the file into a computer.
- 7 Use Notepad or another text editor to edit the display names (the strings after the equals signs).

The following characters can be used in display names. The maximum number of characters per name is four.

- Numbers: 0 to 9
- Alphabetic characters: a to z, A to Z
- Space
- Symbols: ! " # \$ % & ' () * + , - . / : ; < = > ? @ [\] ^ _ ` { | } ~

Note

- Display names will not be displayed correctly if you use any characters other than those listed above. If a display name is longer than four characters, the fifth and following characters are not displayed.
 - You can also change the names of channel numbers that have been assigned to optional input expansion boards. But channel number names are not displayed for boards that are not installed and for channel numbers that (depending on the board) are invalid. For information about channel numbers of input expansion board, *see page 40*.
- 8 Save the edited name file to the USB flash drive, overwriting the old file, and then insert the USB flash drive into the USB MEMORY connector.
 - 9 Repeat steps 2 to 4 to display the Signal Rename sub menu, and then hold the F4 knob down for one second or longer.

The edited file is read into the switcher, and the signal display names in menus change to the edited names.

Tip

The dfs900.ini file contains instructions that specify how to display child window titles in multi-view output (*see page 96*). You can edit those instructions to change the display position and size of child window titles. For details, *see page 99*.

Assigning video input signals to cross-point selection buttons

When using the BKDF-901

Use the following procedure to assign video input signals to PROGRAM and PRESET selection buttons (BLACK and 1 to 12). Each assignment assigns the same signal to the PROGRAM and PRESET selection buttons with the same numbers.

When optional input expansion boards are installed, you can use the SHIFT buttons to assign up to 26 signals, including video input signals 1 to 24, four color matte signals, four still images, and a black signal.

Tip

The following signals are assigned when the switcher is shipped from the factory.

PROGRAM/PRESET selection buttons	Video signals	Video signals (specified with SHIFT button)
BLACK	Black signal	Black signal
1 to 8	Signals connected to the SDI IN1 to IN8 connectors	Signals connected to optional input expansion boards
9	Still image 1	Color matte 1
10	Still image 2	Color matte 2
11	Still image 3	Color matte 3
12	Still image 4	Color matte 4

When using the BKDF-902

Use the following procedure to assign video input signals to KEY/AUX bus selection buttons (BLACK and 1 to 16), M/E bus A and B selection buttons (BLACK and 1 to 16), and PROGRAM and PRESET bus selection buttons (BLACK and 1 to 16). Each assignment assigns the same signal to the KEY/AUX bus selection buttons, the M/E bus A and B selection buttons, and the PROGRAM and PRESET bus selection buttons with the same numbers.

When optional input expansion boards are installed, you can use the SHIFT buttons to assign up to 26 signals, including video input signals 1 to 32, four color matte signals, four still images, and a black signal.

Tip

The following signals are assigned when the switcher is shipped from the factory.

Cross-point selection buttons	Video signals	Video signals (specified with SHIFT button)
BLACK	Black signal	Black signal
1-4	Signals connected to the SDI IN1 to IN4 connectors	Signals connected to optional input expansion boards (IN17-IN20)
5-8	Signals connected to the SDI IN5 to IN8 connectors	Signals connected to optional input expansion boards (IN21-IN24)
9	Signals connected to optional input expansion boards (IN9-IN12)	Still image 1
10		Still image 2
11		Still image 3
12		Still image 4
13	Signals connected to optional input expansion boards (IN13-IN16)	Color matte 1
14		Color matte 2
15		Color matte 3
16		Color matte 4

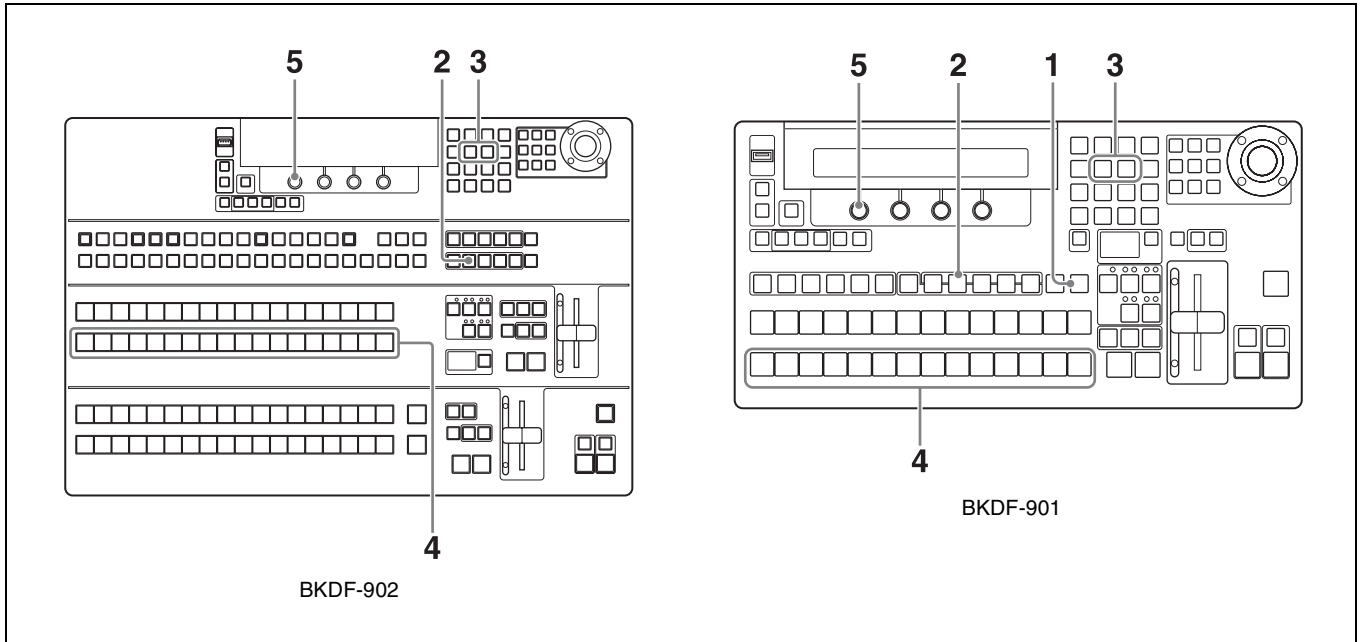

1 When using the **BKDF-901**: If the SHIFT button of the DME/SETUP block is not lit, press it to light it.

When using the **BKDF-902**: Skip to step 2.

2 Press the INPUT button.

A settings sub menu of the Input sub menu appears in the display panel.

3 Press the ◀ or ▶ button in the numeric keypad until the Setting 1 sub menu appears.

“Setting1” appears in the sub menu title display area. If it is already displayed there, you can skip this step.

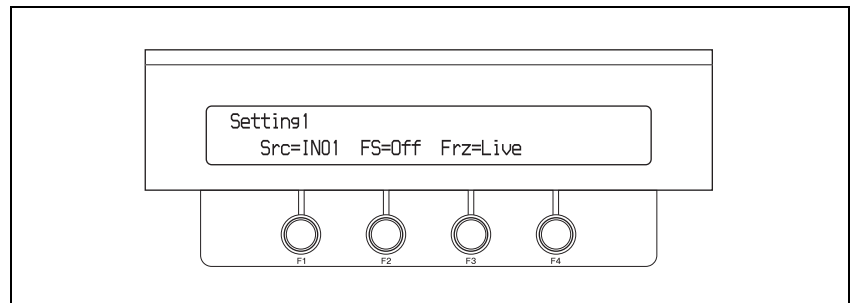

4 When using the **BKDF-901**: In the PRESET selection button row, press the button to which you want to assign a signal.

When using the **BKDF-902**: In the M/E bus B selection button row, press the button to which you want to assign a signal.

If you press the SHIFT button before pressing the button to which you want to assign the signal, you can assign a second signal to that button, in addition to the signal assigned without pressing the SHIFT button.

5 Rotate the F1 knob to select the signal.

A list of signal names, specified with the procedure described in “*Changing signal display names*” (page 74), appears in the menu screen. The selected signal is assigned to the selected button.

- 6** Repeat steps 4 and 5 to assign signals to other buttons.

Using the internal frame synchronizers

Each of the switcher’s input connectors (including those on optional expansion boards) has an internal frame synchronizer. You can enable these synchronizers to input video signals that have not been synchronized with other signals. You can also use the memory of the frame synchronizers to capture still images from input signals, and use those images in place of normal video input.

Note

When SDI signals (SD-SDI or HD-SDI) are being input and it is selected to output ancillary data (page 89), no ancillary data will be output if the frame synchronizers for the corresponding input channels are enabled. To output ancillary data, disable the frame synchronizers.

To enable frame synchronizers

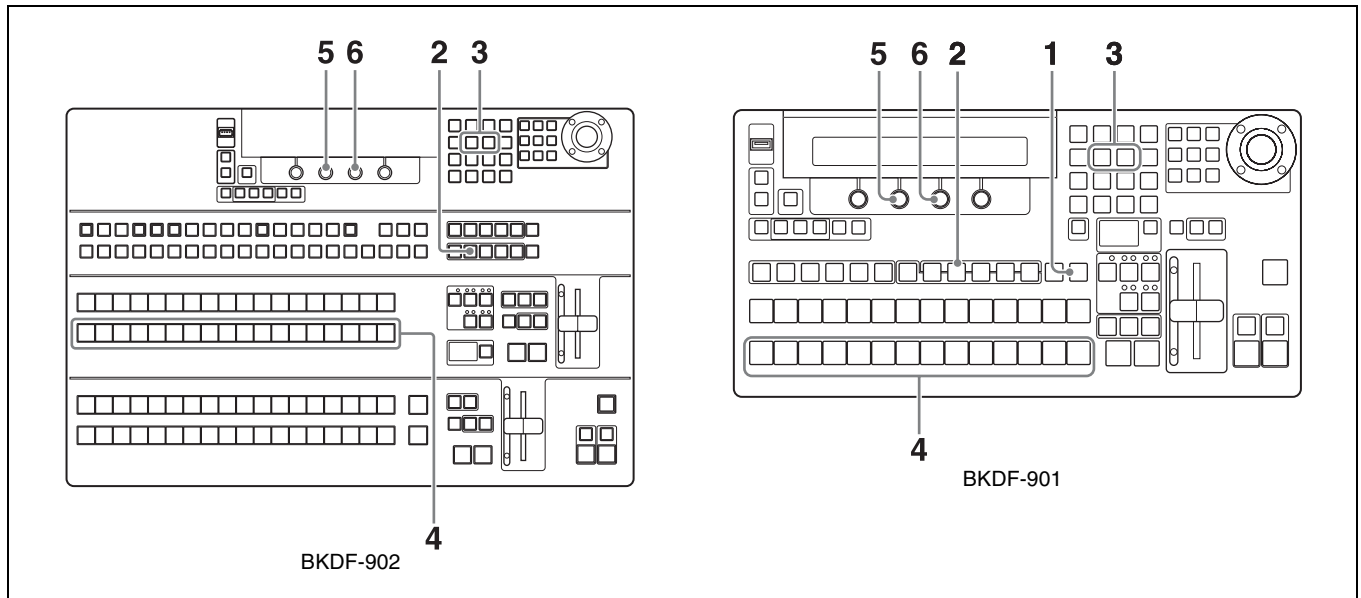

- 1** **When using the BKDF-901:** If the SHIFT button of the DME/SETUP block is not lit, press it to light it.

When using the BKDF-902: Skip to step 2.

- 2** Press the INPUT button.

A settings sub menu of the Input sub menu appears in the display panel.

- 3** Press the ◀ or ▶ button in the numeric keypad until the Setting 1 sub menu appears.

“Setting 1” appears in the sub menu title display area. If it is already displayed there, you can skip this step.

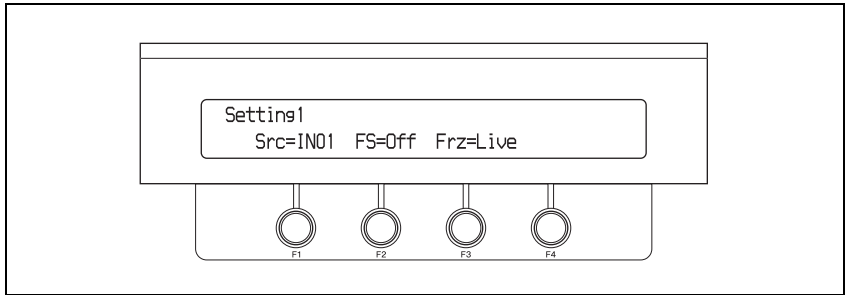

- 4 When using the BKDF-901:** Press the PRESET selection button that selects the input you want to set.
If you want to set an input that has been assigned by using the SHIFT button (*see page 76*), press the SHIFT button before pressing the PRESET selection button.

When using the BKDF-902: Press the M/E bus B selection button that selects the input you want to set.
If you want to set an input that has been assigned by using the SHIFT button (*see page 76*), press the SHIFT button before pressing the M/E bus B selection button.

- 5** Enable frame synchronizer memory by rotating the F2 knob to select “On”.

Note

If you select “Off”, frame synchronizer memory is disabled (and the setting in step **6** is disabled).

- 6** Rotate the F3 knob and select “Live”.

The frame synchronizer is enabled for input video signals.

Note

All settings other than “Live” are settings for capture of still images from input signals. For details, *see “To capture still images from input signals” (page 80)*.

- 7** Repeat steps **4** to **6** as required to set other inputs.

To capture still images from input signals

In step **6** of “*To enable frame synchronizers*” (*page 79*), select an item other than “Live” and make the settings for still image capture and output. You can select the following settings.

Frm: Capture a frame image from the input signal

Even: Capture a field image (even field) from the input signal

Odd: Capture a field image (odd field) from the input signal

Notes

- A frame or field image is captured as soon as you select one of Frm, Even, or Odd.
- When capturing still images from an up-converted input signal (*see page 81*), only Frm can be selected.
- To store a still image captured from input signals, you must first output it to program output. For details about how to store still images, *see page 118*.

- When you download a still image to the memory of an input (*see page 118*), the frame synchronizer mode of that input is set automatically to On. At the same time, the output signal is set automatically to Frm. Change the setting as required after downloading the still image.

Making up-convert input settings

The optional BKDF-910 and BKDF-911 input expansion boards feature internal up-converters. When these boards are installed and the switcher's video format is set to HD signals (*see page 71*), you can select the conversion mode used by the up-converters to up-convert SD format video input signals to HD format video input signals.

For more information about the BKDF-910 and BKDF-911, see page 31. For information about how to install them, see page 39.

Notes

- The up-converters can be set only when the switcher's video format (*see page 71*) is set to HD signals.
- When the video format is switched from HD to SD, the up-converter settings of each input channel are set automatically to OFF. Make the up-converter settings again when you return the video format to HD.
- The following table lists the input channels on the input expansion boards that are equipped with up-converters.

Input expansion board	Inputs with up-converters
BKDF-910 4 SDI Input Board	SDI IN1 and SDI IN2
BKDF-911 2 SD Video Input Board	All inputs

For more information about the channel numbers for channels with up-converters, and how they are displayed in the input display, see page 39.

- Different up-converter settings can be specified for each input channel. However, on the BKDF-910 it is not possible to turn individual channels OFF. When the up-converter on one channel is turned OFF, the other channel is turned OFF automatically.
- On the BKDF-911, up-converters cannot be turned OFF when the video format is HD.
- Up-converting a finely detailed image (such as spray from a fountain) may result in some blurriness.
- The switcher's standard input connectors (SDI IN1 to SDI IN8) are not equipped with up-converters.

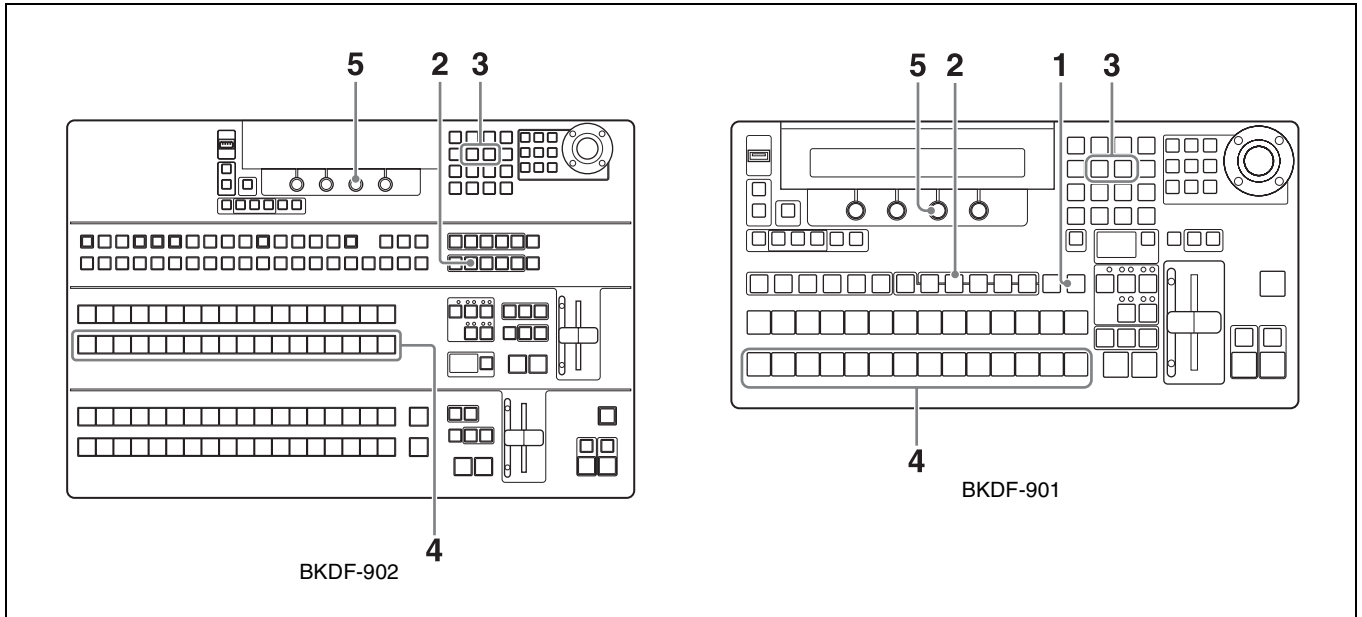

1 When using the BKDF-901: If the SHIFT button of the DME/SETUP block is not lit, press it to light it.

When using the BKDF-902: Skip to step 2.

2 Press the INPUT button.

A settings sub menu of the Input sub menu appears in the display panel.

3 Press the ◀ or ▶ button in the numeric keypad until the Setting 2 sub menu appears.

“Setting2” appears in the sub menu title display area. If it is already displayed there, you can skip this step.

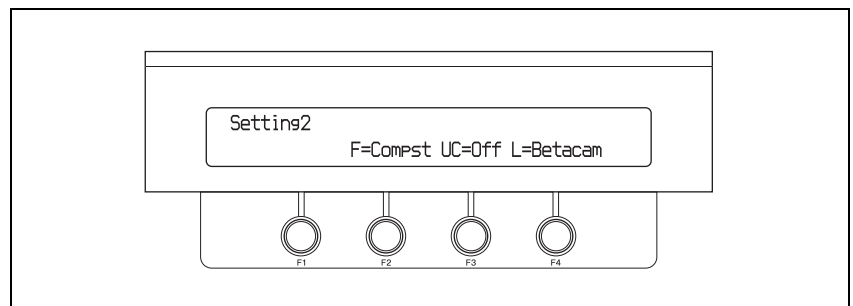

4 When using the BKDF-901: Press the PRESET selection button that selects the input you want to set.
If you want to set an input that has been assigned by using the SHIFT button (see page 76), press the SHIFT button before pressing the PRESET selection button.

When using the BKDF-902: Press the M/E bus B selection button that selects the input you want to set.
If you want to set an input that has been assigned by using the SHIFT button (see page 76), press the SHIFT button before pressing the M/E bus B selection button.

5 Rotate the F3 knob to select the conversion mode.

4:3: Input with 4:3 aspect ratio (add black to left and right sides of picture)

4:3BGS: Input with 4:3 aspect ratio (Add still images to the left and right sides of picture. The two sides of a downloaded still image file (HDTV size) are added to the video input.)

SQ: Input as squeeze video

LB: Input as letterbox video

Off: Do not up-convert

Notes

- For information about how to download still images from still image storage memory to the memory of switcher inputs, see *page 118*.
- When you select 4:3BGS, download an HDTV size still image. The left and right sides of the picture will not be displayed normally if no image is downloaded or if the downloaded image is a SDTV size image.

Specifying the signal type of analog input signals

When you are using the optional BKDF-911 2 SD Video Input Board, specify the signal type of the analog signals that will be input to the board.

For more information about the BKDF-911, see page 31. For information about how to install it, see page 39.

Note

Regardless of this setting, the only signals that can be input to the COMP connector of the BKDF-911 are SD analog composite signals.

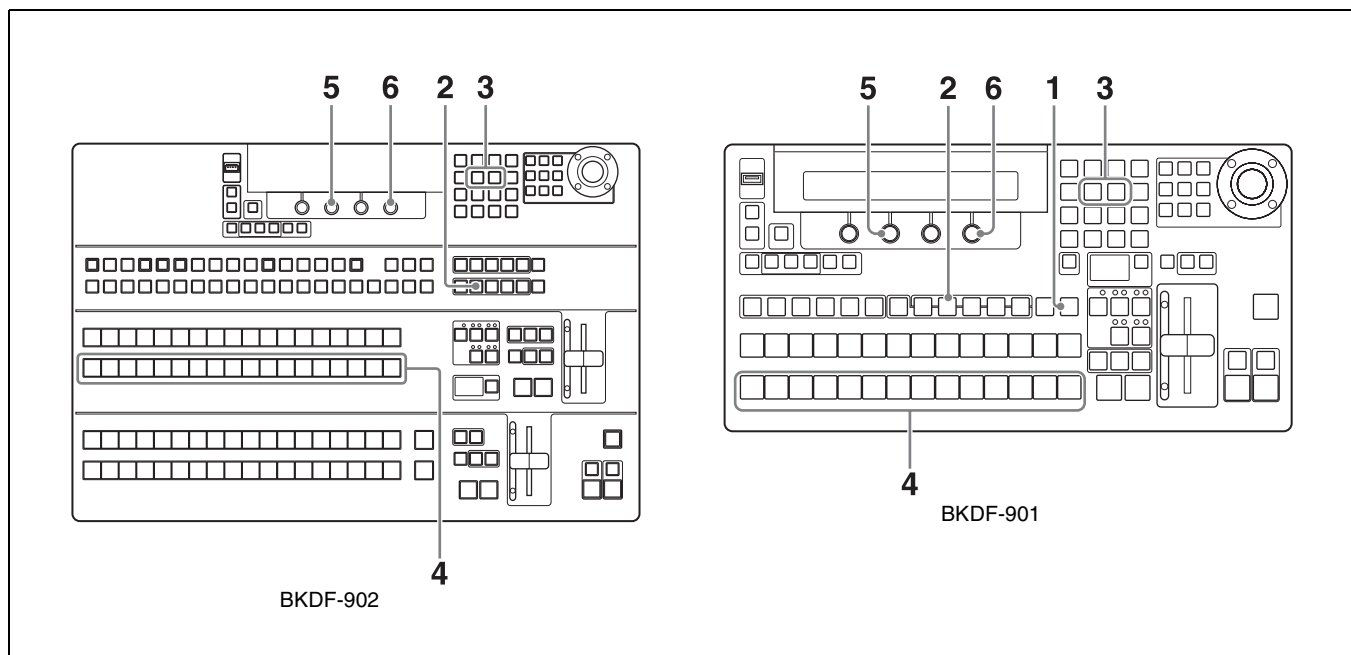

1 **When using the BKDF-901:** If the SHIFT button in the DME/SETUP block is not lit, press it to light it.

When using the BKDF-902: Skip to step 2.

2 Press the INPUT button.

A settings sub menu of the Input sub menu appears in the display panel.

- 3 Press the ◀ or ▶ button in the numeric keypad until the Setting 2 sub menu appears.

“Setting2” appears in the sub menu title display area. If it is already displayed there, you can skip this step.

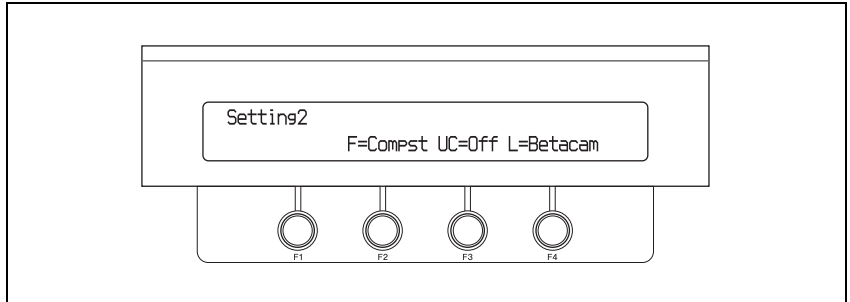

- 4 **When using the BKDF-901:** Press the PRESET selection button that selects the analog input you want to set.
If you want to set an analog input that has been assigned by using the SHIFT button (see page 76), press the SHIFT button before pressing the PRESET selection button.

When using the BKDF-902: Press the M/E bus B selection button that selects the analog input that you want to set.
If you want to set an analog input that has been assigned by using the SHIFT button (see page 76), press the SHIFT button before pressing the M/E bus B selection button.

- 5 Rotate the F2 knob to select the type of signal that will be input.

Compst: Analog composite signal

Y/CB/CR: Analog component (color difference) signal

Notes

- Analog HD component signals cannot be input.
- The following table shows the input signals and the numbers assigned to each input channel (see page 39).

Setting of step 5	Name of BKDF-911 connector	Input signal	BKDF-911 installation position and channel number			
			Lower tray		Upper tray	
			Left	Center	Left	Center
Compst	COMP/Y	Composite signal	IN09	IN13	IN17	IN21
	R-γ ^(a)	—	—	—	—	—
	B-γ ^(a)	—	—	—	—	
	COMP	Composite signal	IN10	IN14	IN18	IN22

Setting of step 5	Name of BKDF-911 connector	Input signal	BKDF-911 installation position and channel number			
			Lower tray		Upper tray	
			Left	Center	Left	Center
Y/CB/CR	COMP/Y	Luminance (Y) signal	IN09	IN13	IN17	IN21
	B-Y	Color difference (B-Y) signal				
	R-Y	Color difference (R-Y) signal				
	COMP	Composite signal	IN10	IN14	IN18	IN22

a) Connector is disabled

- 6** If you selected Y/CB/CR in step 5, rotate the F4 knob to select the level of the component input signals.

Betacam: Betacam level

SMPTE: SMPTE level

Note

Settings of step 6 can be available only when the switcher's video format (see page 71) is set to 525/59, 720/59, or 1080/59.

Specifying the signal type of DVI input signals

When you are using the optional BKDF-912 2 DVI Input Board, specify the picture size and aspect ratio conversion modes for the DVI signals that will be input to the board.

For more information about the BKDF-912, see page 31. For information about how to install it, see page 39.

Note

Depending on the video format setting of this switcher (page 71), select the DVI input signal resolution from the values in the following table. If you specify a resolution other than the values shown in the table, images may be unable to be reproduced normally.

Video format setting	DVI input signal resolution
525/59 or 625/50	VGA (640 × 480) SVGA (800 × 600) XGA (1024 × 768)
720/50 or 720/59	XGA (1024 × 768) SXGA (1280 × 1024) WXGA (1280 × 768)
1080/50 or 1080/59	XGA (1024 × 768) SXGA (1280 × 1024) WXGA (1280 × 768) UXGA (1600 × 1200) WSXGA (1680 × 1050) WUXGA (1920 × 1200)

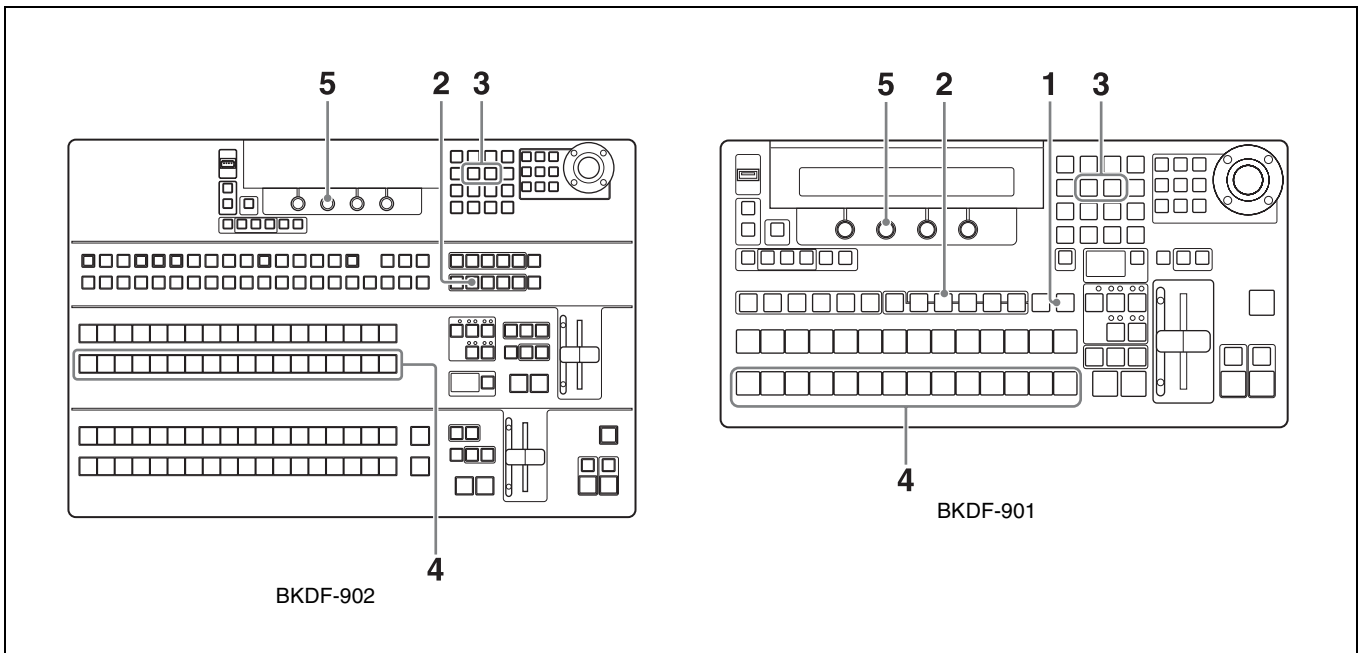

1 When using the **BKDF-901**: If the SHIFT button of the DME/SETUP block is not lit, press it to light it.

When using the **BKDF-902**: Skip to step 2.

2 Press the INPUT button.

A settings sub menu of the Input sub menu appears in the display panel.

3 Press the ◀ or ▶ button in the numeric keypad until the DVI sub menu appears.

“DVI” appears in the sub menu title display area. If it is already displayed there, you can skip this step.

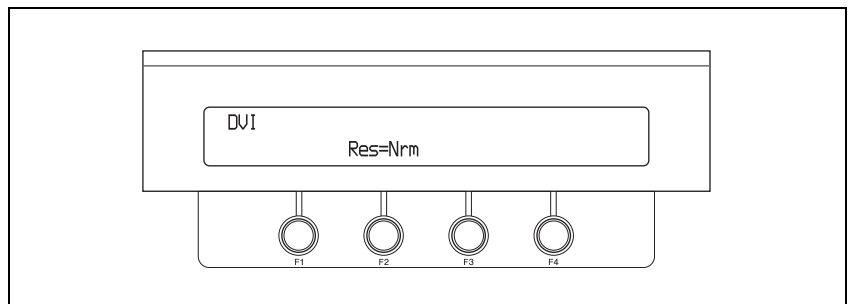

4 When using the **BKDF-901**: Press the PRESET selection button that selects the DVI input you want to set.

If you want to set a DVI input that has been assigned by using the SHIFT button (*see page 76*), press the SHIFT button before pressing the PRESET selection button.

When using the **BKDF-902**: Press the M/E bus B selection button that selects the DVI input that you want to set.

If you want to set a DVI input that has been assigned by using the SHIFT button (*see page 76*), press the SHIFT button before pressing the M/E bus B selection button.

- 5** Rotate the F2 knob to select the picture size and aspect ratio conversion modes.

Normal: Do not convert either the picture size or aspect ratio.

Zoom: Expand the screen size to match the horizontal width of a 16:9 aspect ratio picture (vertical and horizontal zoom ratios are the same).

Full: Modify the picture size to match a 16:9 aspect ratio picture, so that all areas of the picture are displayed (the vertical and horizontal modification ratios are different).

Application of conversion settings of step 5 to identical picture

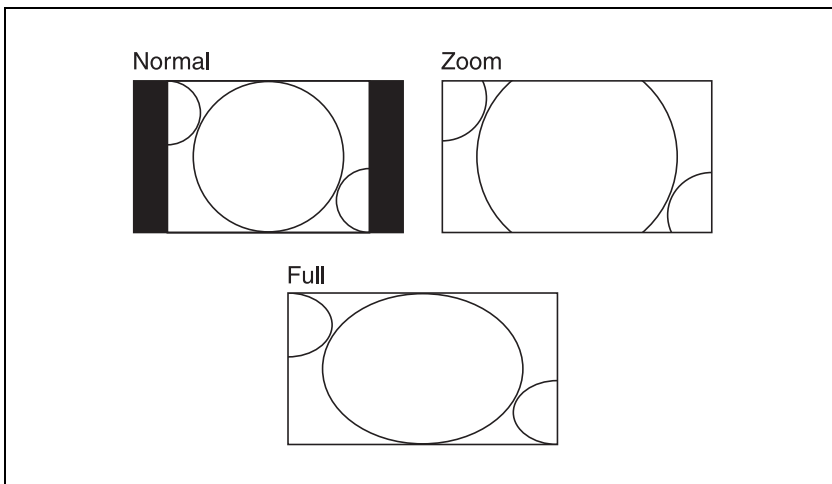

Note

If you select Normal when the switcher's video format is set to HD signals (see page 71), black is added at the top, bottom, left, and right of the picture. However, the top and bottom of the picture are cut if the input video is UXGA or WUXGA. If you select Zoom, the top and bottom are cut for all types of video (the amount cut depends on the picture size).

Adjusting input signals

Use the following procedure to adjust the various levels of video input signals.

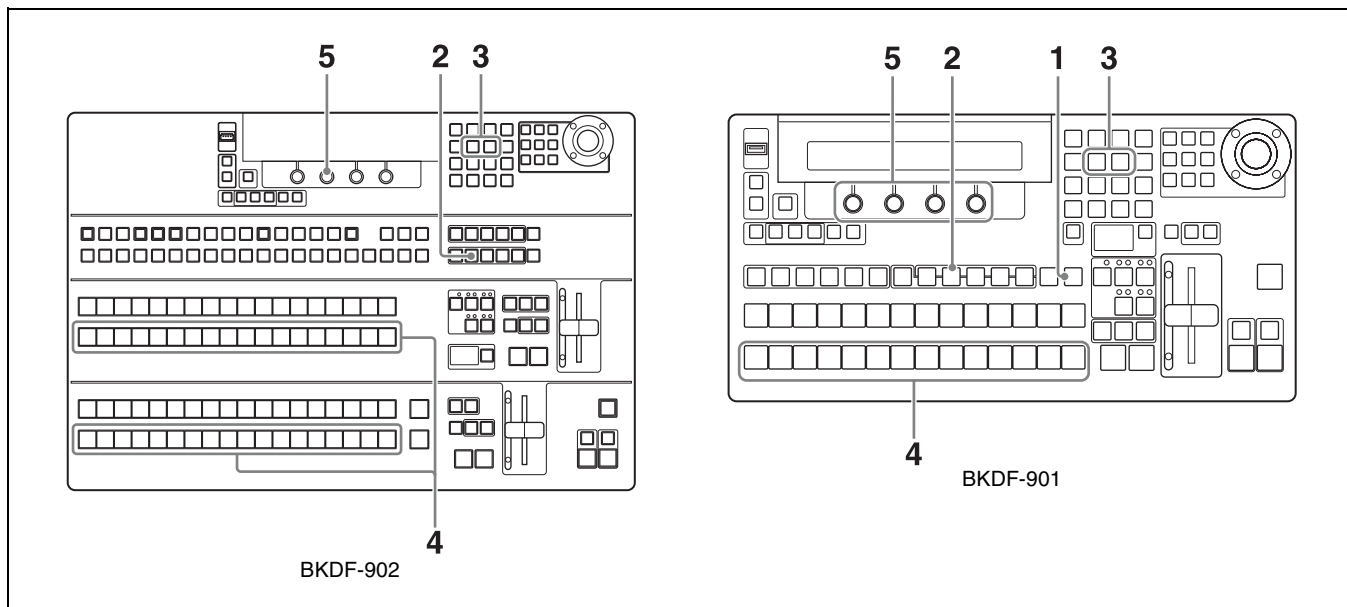

- 1 When using the BKDF-901:** If the SHIFT button of the DME/SETUP block is not lit, press it to light it.

When using the BKDF-902: Skip to step 2.

- 2** Press the INPUT button.

A settings sub menu of the Input sub menu appears in the display panel.

- 3** Press the ◀ or ▶ button in the numeric keypad until the Input Process1 or Input Process2 sub menu appears, depending on what you want to adjust.

“Input Process1” or “Input Process2” appears in the sub menu title display area. If the title you want is already displayed there, you can skip this step.

Example with “Input Process1” displayed:

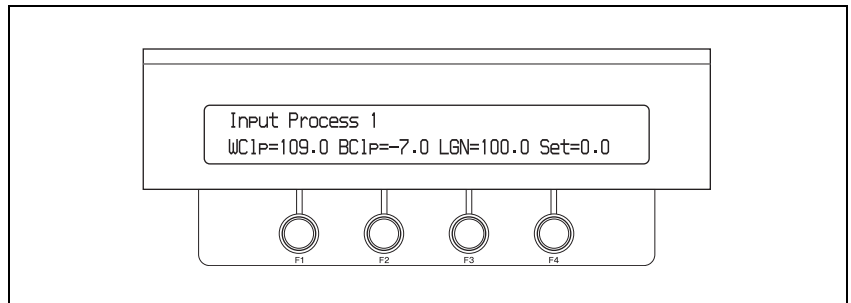

- 4 When using the BKDF-901:** Press the PRESET selection button that selects the input you want to set.
If you want to set an input that has been assigned by using the SHIFT button (see page 76), press the SHIFT button before pressing the PRESET selection button.

When using the BKDF-902: Press the M/E bus B selection button or the PRESET bus selection button that selects the input you want to set.
If you want to set an input that has been assigned by using the SHIFT button (see page 76), press the SHIFT button before pressing the M/E bus B selection button or the PRESET bus selection button.

- 5** Rotate the F1 to F4 knobs to make the settings.

The signal characteristics set by the sub menus and the correspondence between knobs and parameters are as follows.

Input Process1 sub menu

Knob	Parameter	Description	Setting range
F1	WC1p	Set the white clip level	50.0 to 109.0
F2	BC1p	Set the black clip level	-7.0 to 50.0
F3	LGN	Set the luminance signal gain	0.00 to 200.00
F4	Set	Adjust the black signal level	0.0 to 100.0

Input Process2 sub menu

Knob	Parameter	Description	Setting range
F1	CC1p	Set the chroma signal clip level	50.0 to 111.0
F2	CGN	Set the chroma signal gain	0.00 to 200.00
F3	H Phase Trim ^{a)}	Adjust the horizontal phase ^{a)}	-4 to 4

Knob	Parameter	Description	Setting range
F4	Hue	Adjust the hue	0.0 to 359.5

a) Valid only when the BKDF-911 2 SD Video Input Board is installed

Making Settings Related to Output Signals

Selecting output signals for AUX output

Including the four standard video outputs (PGM1/2 and AUX1/2), you can use up to 12 video outputs by adding option boards.

Tips

You can assign input signals, internally processed signals, or program outputs to the output connectors of AUX1, AUX2, and output expansion boards (SDI, SD VIDEO, and DVI).

You can also assign multi-view outputs to those output connectors when you install the optional BKDF-950 Multi Viewer Board in the processor unit.

When the input is SDI signals (HD-SDI or SD-SDI), you can select whether to output ancillary data such as multiplexed audio and timecode.

Note

The signals output from the PGM1 and PGM2 outputs cannot be changed.

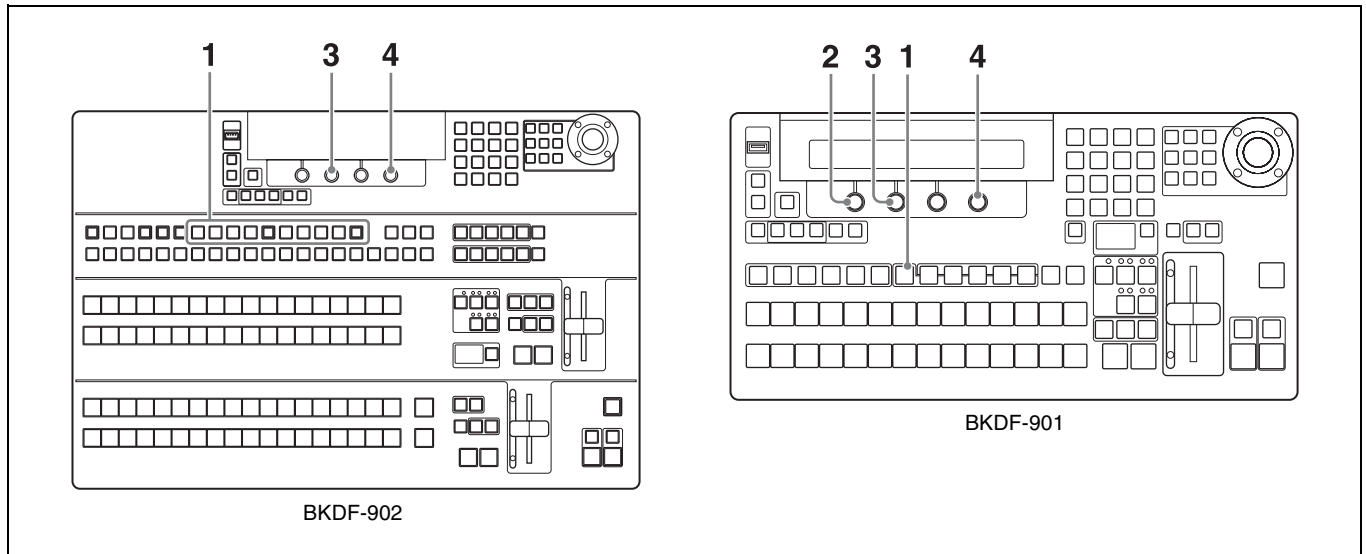

1 When using the BKDF-901: Press the AUX button.

When using the BKDF-902: Press one of the AUX1 to AUX10 buttons.

Note

The AUX3 to AUX10 buttons that correspond to channels on installed output expansion boards are enabled (buttons with no corresponding channels are not enabled). When you are using the BKDF-961 and BKDF-962 output expansion boards, some output channel numbers are invalid. For details, see page 39.

The Aux (AUX output assignments) sub menu appears in the display panel.

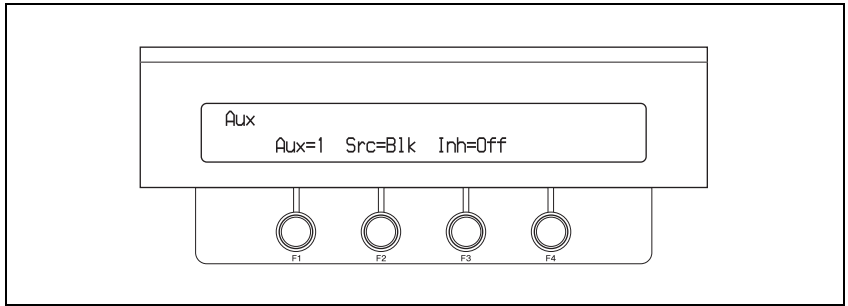

- 2** When using the BKDF-901: Rotate the F1 knob to select an output, from AUX1 to AUX10.

When using the BKDF-902: Skip to step 3.

Note

AUX3 to AUX10 are available only when optional expansion boards are installed. For details, *see page 39*.

- 3** Rotate the F2 knob to select the signal to assign.

BLK: Black signal

IN01 to IN24: Video inputs

STL01 to STL04: Still images 1 to 4 stored in the processor unit

MAT1 to MAT4: Color matte signals 1 to 4

MV1 and MV2: Multi-view output

PGM: Program output

PVW: Preview output

CLN: Clean output (program output without downstream key)

KOut: Key output

MPGM: M/E output (when using the BKDF-902)

MPVW: M/E preview output (when using the BKDF-902)

Tips

- If, after step 3, you rotate the F3 knob to set the Inh (Inhibit) item to On, the AUX output signal cannot be changed from the control panel. Control is possible only by remote control from an optional AUX BUS remote controller.
- For more information about screen settings for multi-view output, *see page 96*.

Notes

- When optional input expansion boards have been installed, signal names corresponding to the installation positions appear for IN09 to IN24. For details, *see page 39*.
- When the display names of input signals or internal signals have been changed (*see page 74*), the user-specified names appear.

- 4** When HD-SDI or SD-SDI signals are being input, rotate the F4 knob to select whether to output ancillary data (audio, timecode, etc.).

Off: Do not output ancillary data in the input signals.

On: Output ancillary data in the input signals.

Note

To output ancillary data, disable the frame synchronizers (page 79). It will also be disabled to use a function which captures still images from input video signals (page 80).

Making down-convert output settings

The optional BKDF-960 and BKDF-961 output expansion boards feature internal down-converters. When these boards are installed and the switcher's video format is set to HD signals (see page 71), you can select the conversion mode used by the down-converters to down-convert HD format video signals to SD format video output signals.

For more information about the BKDF-960 and BKDF-961, see page 31. For information about how to install them, see page 39.

Notes

- The down-converters can be set only when the switcher's video format (see page 71) is set to HD signals.
- When the video format is switched from HD to SD, the down-converter settings of each input channel are set automatically to OFF. Make the down-converter settings again when you return the video format to HD.
- The following table lists the output channels on the output expansion boards that are equipped with down-converters.

Output expansion board	Outputs with down-converters
BKDF-960 4 SDI Output Board	SDI OUT1 and SDI OUT2
BKDF-961 2 SD Video Output Board	All outputs

For more information about the channel numbers for channels with down-converters, and how they are displayed in the output display, see page 39.

- Different down-converter settings can be specified for each output channel. However, on the BKDF-961 it is not possible to disable down-converters when the video format is HD.
- The switcher's standard output connectors (PGM1, PGM2, AUX1, AUX2) are not equipped with down-converters.

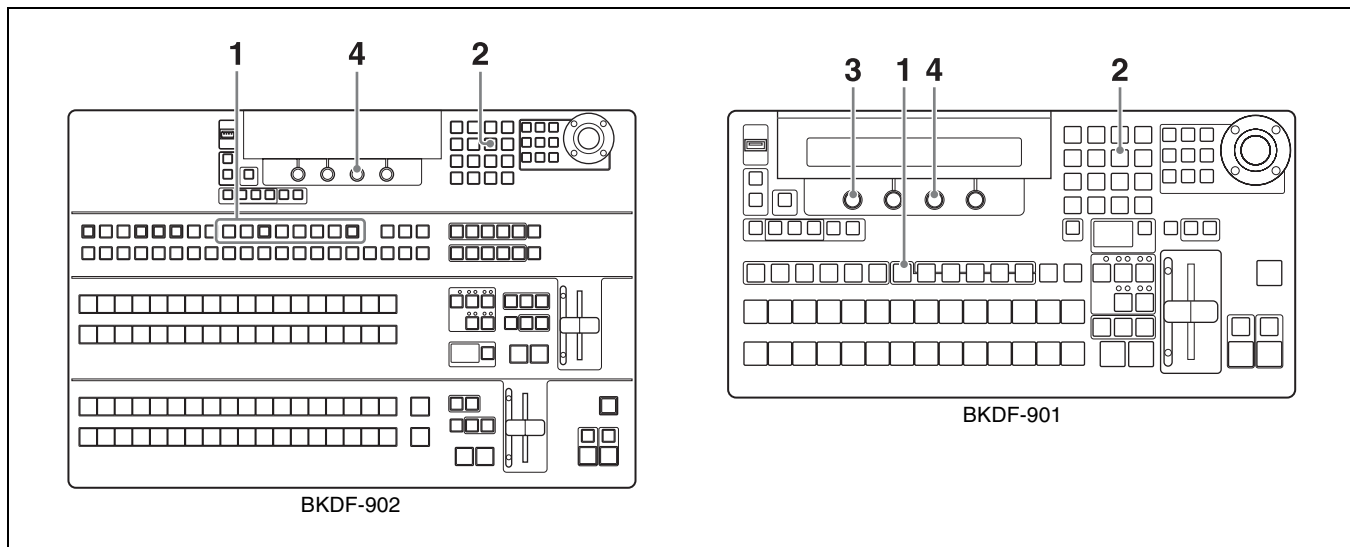

1 When using the BKDF-901: Press the AUX button.

When using the BKDF-902: Among the AUX03 to AUX10 buttons, press the button that selects the AUX output that you want to set.

The Aux (AUX output assignment settings) sub menu appears in the display panel.

2 Press the \triangleright button in the numeric keypad until the Output (output detailed settings) sub menu appears.

“Output” appears in the sub menu title display area. If it is already displayed there, you can skip this step.

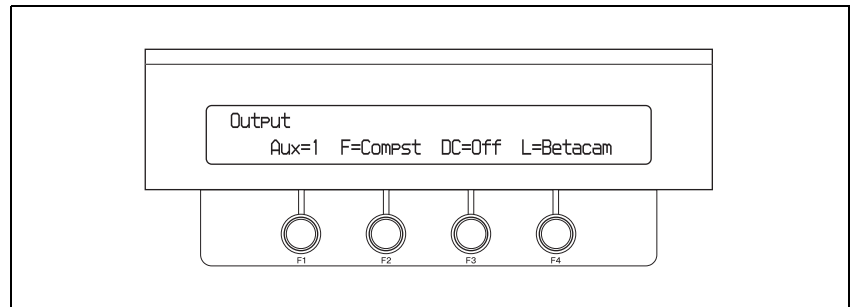

3 When using the BKDF-901: Rotate the F1 knob to select the item that selects the AUX output that you want to set, from among AUX03 to AUX10.

When using the BKDF-902: Skip to step 4.

Note

AUX1 and AUX2 are not provided with down-converting capability.

4 Rotate the F3 knob to select the conversion mode.

4:3: Output with 4:3 aspect ratio (edge cropped output)

SQ: Output as squeeze video

LB: Output as letterbox video

Off: Do not down-convert

Specifying the signal type of analog output signals

When you are using the optional BKDF-961 2 SD Video Output Board, specify the signal type of the analog signals that will be output from the board.

For more information about the BKDF-961, see page 31. For information about how to install it, see page 39.

Note

Regardless of this setting, signals output from the COMP connector of the BKDF-961 are always SD analog composite signals.

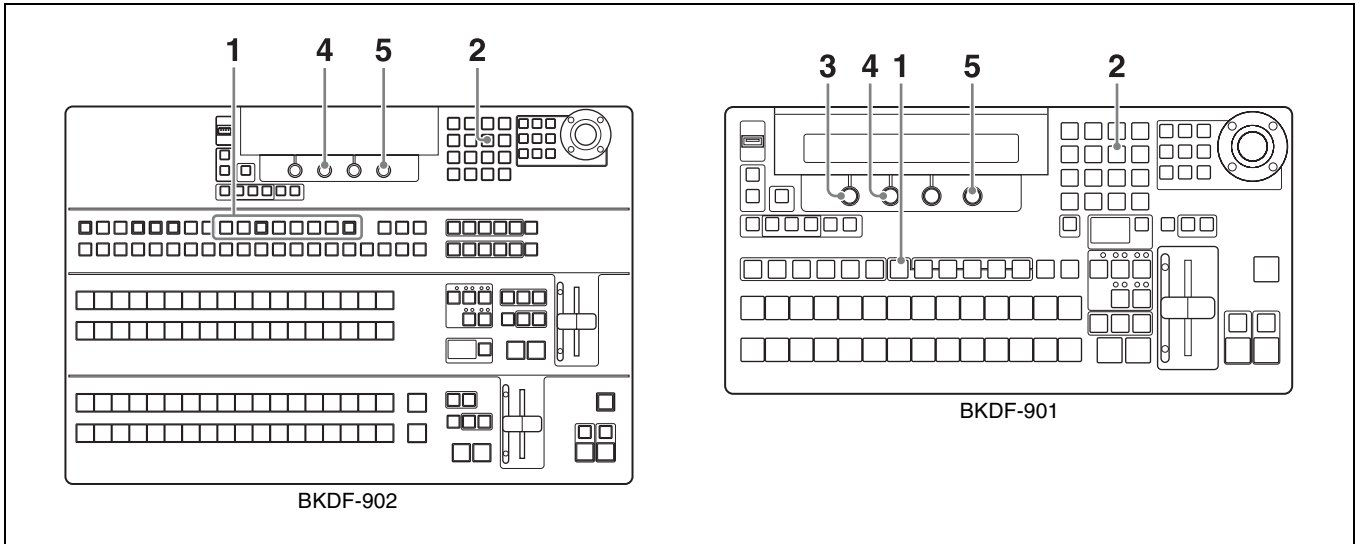

1 When using the **BKDF-901**: Press the AUX button.

When using the BKDF-902: From among the buttons AUX03 to AUX10, press one to which analog output has been assigned. The Aux (AUX output assignment settings) sub menu appears in the display panel.

2 Press the ◀ or ▶ button in the numeric keypad until the Output (output detailed settings) sub menu appears.

“Output” appears in the sub menu title display area. If it is already displayed there, you can skip this step.

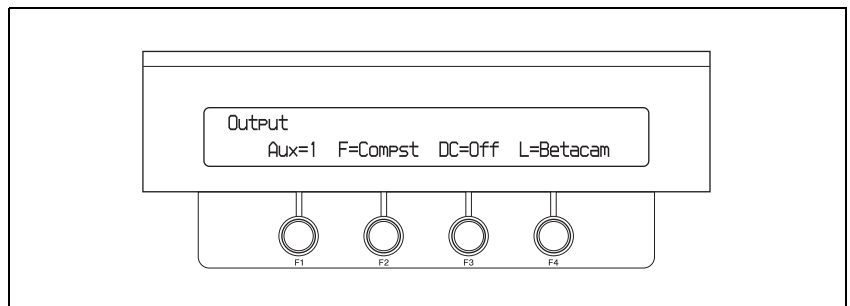

3 When using the **BKDF-901**: Rotate the F1 knob to select an item from among AUX03 to AUX10 to which analog output has been assigned.

When using the BKDF-902: Skip to step 4.

4 Rotate the F2 knob to select the output signal type.

Compst: Analog composite signal

Y/CB/CR: Analog component (color difference) signal

GBR/wSync: Analog component (RGB) signal (sync signal multiplexed into G signal)

Notes

- Analog HD component signals cannot be output.
- The following table lists the signals to be connected and the number assigned to each input channel (see page 39).

Setting of step 4	Name of BKDF-961 connector	Output signal	BKDF-961 installation position and channel number	
			Lower tray	Upper tray
			Left	Left
Compst	COMP/Y	Composite signal	AUX03	AUX07
	B-Y ^{a)}	–	–	–
	R-Y ^{a)}	–	–	–
	COMP	Composite signal	AUX04	AUX08
Y-CB/CR	COMP/Y	Y (luminance) signal	AUX03	AUX07
	B-Y	Color difference (B-Y) signal		
	R-Y	Color difference (R-Y) signal		
	COMP	Composite signal	AUX04	AUX08
GBR/wSync	COMP/Y	G (green) signal (with multiplexed sync signal)	AUX03	AUX07
	B-Y	B (blue) signal		
	R-Y	R (red) signal		
	COMP	Composite signal	AUX04	AUX08

a) Connector is disabled

- 5** If you selected Y/CB/CR in step **4**, rotate the F4 knob to select the level of the component output signals.

Betacam: Betacam level

SMPTE: SMPTE level

Note

Settings of step **5** can be available only when the switcher's video format (see page 71) is set to 525/59, 720/59, or 1080/59.

Specifying the signal type of DVI output signals

When you are using the optional BKDF-962 2 DVI Output Board, specify the signal type of the DVI signals that will be output from the board.

For more information about the BKDF-962, see page 31. For information about how to install it, see page 39.

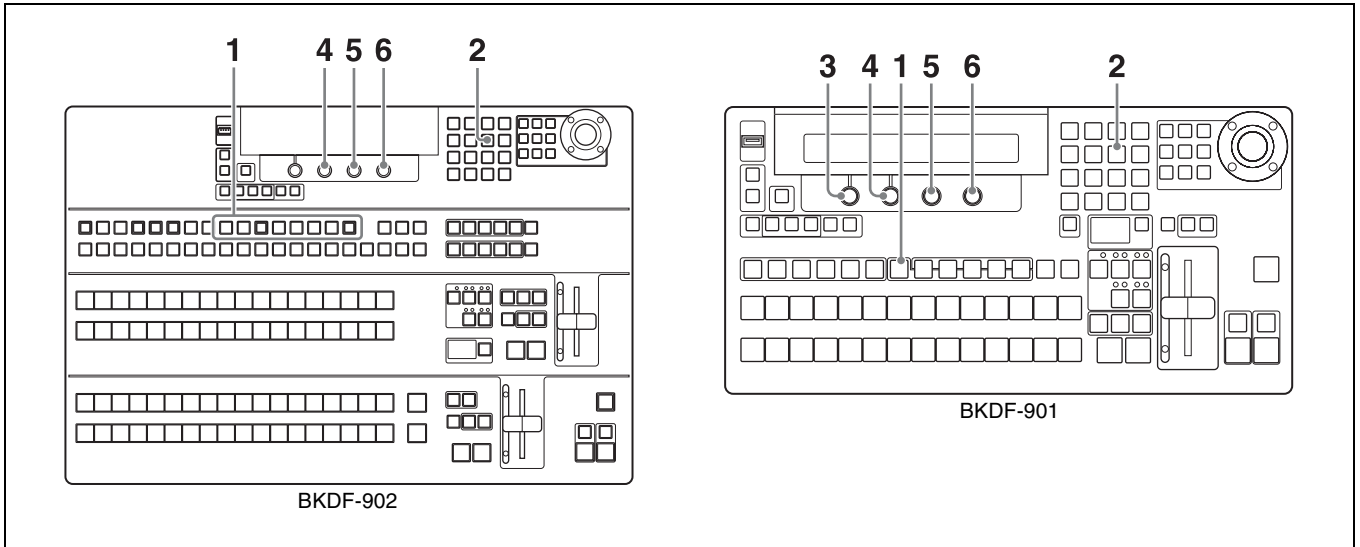

1 When using the **BKDF-901**: Press the AUX button.

When using the BKDF-902: From among the buttons AUX03 to AUX10, press one to which DVI output has been assigned.

The Aux (AUX output assignment settings) sub menu appears

2 Press the ◀ or ▶ button in the numeric keypad until the DVI (DVI output settings) sub menu appears.

“DVI” appears in the sub menu title display area. If it is already displayed there, you can skip this step.

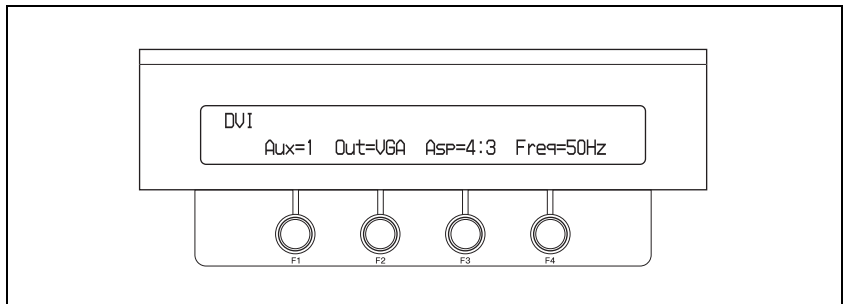

3 When using the **BKDF-901**: Rotate the F1 knob to select an item from among AUX03 to AUX10 to which DVI output has been assigned.

When using the BKDF-902: Skip to step 4.

4 Rotate the F2 knob to select the output signal type from the types listed in the following table.

Parameter	Output signal	Video format setting Yes: Can be selected No: Cannot be selected (the parameter does not appear)		
		525/59 or 625/50	720/50 or 720/59	1080/50 or 1080/59
SVGA	SVGA signal (800 x 600)	Yes	No	No

Parameter	Output signal	Video format setting Yes: Can be selected No: Cannot be selected (the parameter does not appear)		
		525/59 or 625/50	720/50 or 720/59	1080/50 or 1080/59
WXGA	WXGA signal (1280 x 768)	No	Yes	No
SXGA	SXGA signal (1280 x 1024)	No	Yes	Yes
UXGA	UXGA signal (1600 x 1200)	No	No	Yes ^{a)}
WSXGA	WSXGA signal (1680 x 1050)	No	No	Yes
HDTV	Full HDTV size (1920 x 1080) signal	No	No	Yes
WUXGA	WUXGA signal (1920 x 1200)	No	No	Yes ^{a)}

a) Only digital signals are output. Analog signals are not output.

Notes

- Depending on the video format setting (*see page 71*), some parameters cannot be selected.
- If you select HDTV, color difference component signals (Y/P_b/P_r) are output from the analog signal output connectors of the BKDF-962. If you select another parameter (excluding UXGA and WUXGA), RGB signals are output.

5 If you selected SXGA or UXGA in step **4**, rotate the F3 knob to select the output mode.

4:3: Cut both sides of the picture and output with aspect ratio 4:3 (edge crop output).

LB: Output letterbox video.

Note

When 4:3 is selected, the amount cut at the sides of the picture differs between SXGA and UXGA.

6 Rotate the F4 knob to specify the system format of the output destination.

50Hz: When the system format of the output destination is 50 Hz.

60Hz: When the system format of the output destination is 60 Hz.

Note

50Hz can be selected only when the switcher's video format (*see page 71*) is set to 625/50, 720/50, or 1080/50. This setting affects only digital signals output from the BKDF-962.

Making multi-view output settings

The multi-view function is available when you install the optional BKDF-950 Multi Viewer Board in the processor unit. By assigning multi-view output to an AUX connector and connecting a video monitor, you can check video on a monitor screen divided into up to 16 partitions, including input video, program output video, and preview video.

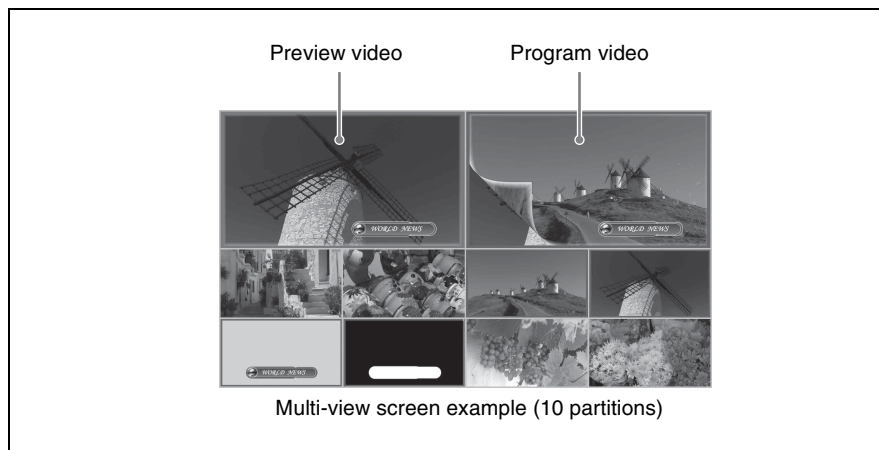

You can install up to two BKDF-950 boards, and set output patterns for each board in both the MV1 Window and MV2 Window sub menus. You also change the size and position of child window titles, and add frames to indicate that the signal assigned to a child window is program or preview output or a component element of program or preview output (the currently selected input, a key signal, and so on).

For details about the BKDF-950 and information about how to install it, see page 46.

Note

The MV1 Window and MV2 Window sub menus cannot be set if the BKDF-950 board is not installed.

To specify the partition type and assign output video to child windows

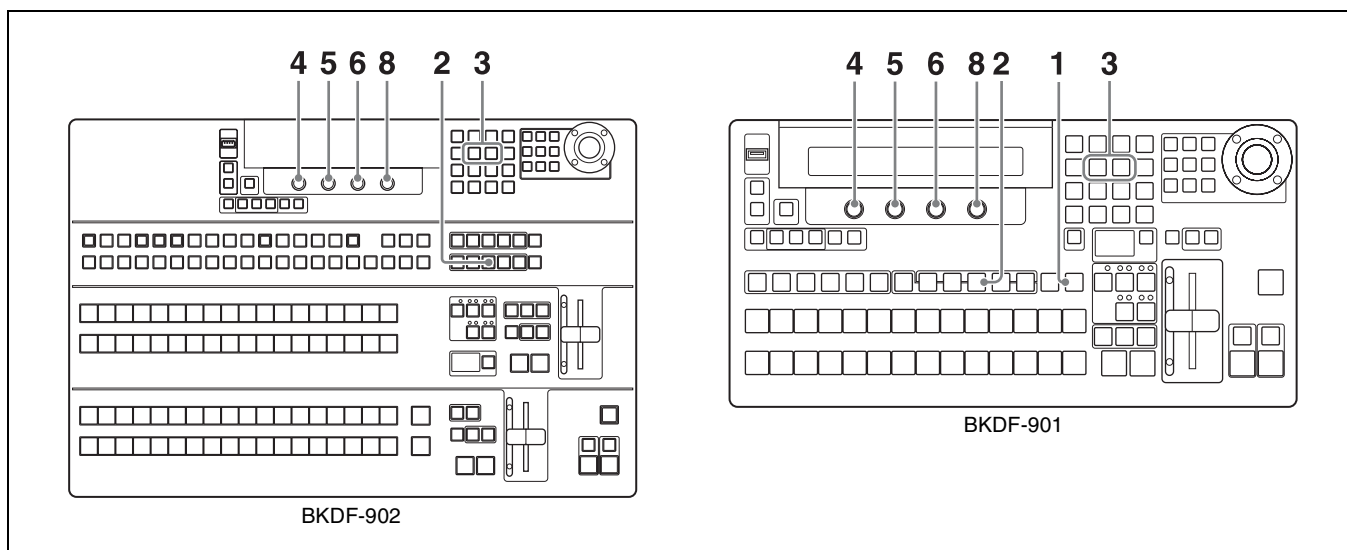

1 When using the BKDF-901: If the SHIFT button of the DME/SETUP block is not lit, press it to light it.

When using the BKDF-902: Skip to step 2.

2 Press the MV button.

A settings sub menu of the MV (multi-view output settings) sub menu appears in the display panel.

- 3 Press the ◀ or ▶ button in the numeric keypad until the MV1 Window or MV2 Window sub menu appears.

As shown in the following table, the sub menu title in the display panel indicates the BKDF-950 board targeted by this procedure. If the title that you want is already displayed there, you can skip this step.

Name displayed in sub menu title display area	Description
MV1 Window	Select to make settings for the BKDF-950 connected to MV1 socket.
MV2 Window	Select to make settings for the BKDF-950 connected to MV2 socket.

Example with MV1 Window displayed:

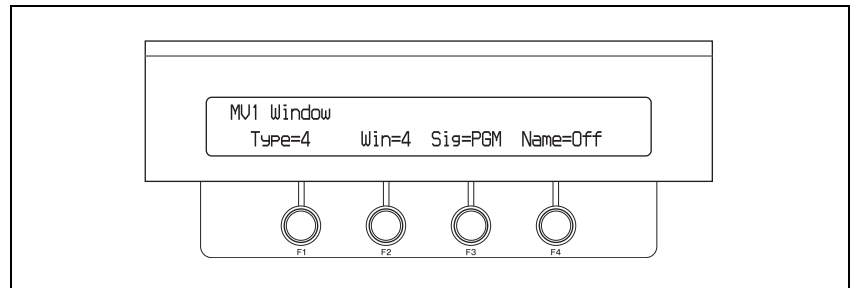

Note

Both the MV1 Window and MV2 Window sub menus appear when a BKDF-950 is installed in either socket, but settings made in a sub menu that corresponds to an empty socket (one with no BKDF-950 installed) are ignored.

- 4 Rotate the F1 knob to select the number of multi-view partitions.
You can select from 4, 10, or 16.
- 5 Rotate the F2 knob to select the number of the child window that you want to set.

Depending on the number of partitions selected in step 4, select a number from 1 to 16.

For more information about partitions in the multi-view screen and child window numbers, see page 99.

- 6 Rotate the F3 knob to select the video output to the child window.

- BLK:** Black signal
- IN01 to IN24:** Video inputs
- STL1 to STL4:** Still images 1 to 4 stored in the processor unit
- MAT1 to MAT4:** Color matte signals 1 to 4.
- PGM:** Program output
- PVW:** Preview output
- CLN:** Clean output (program output without downstream key)
- KOut:** Key signal
- MPGM:** M/E output (when using the BKDF-902)
- MPVW:** M/E preview output (when using the BKDF-902)

Notes

- When optional input expansion boards have been installed, signal names corresponding to the installation positions appear for IN09 to IN24. For details, *see page 39*.
- When the display names of input signals or internal signals have been changed (*see page 74*), the user-specified names appear.

7 Repeat steps **5** and **6** to set other child windows.

8 Rotate the F4 knob to turn display of the child window titles on or off.

- On:** Display titles.
- Off:** Do not display titles.

Notes

- The settings made in step **8** are reflected in all child windows. It is not possible to make title display settings separately for individual windows.
- The display of child window titles is turned off automatically when you change the multi-view window partition type. If you want to display titles, turn title display on again.

Multi-view window partition types and child window numbers

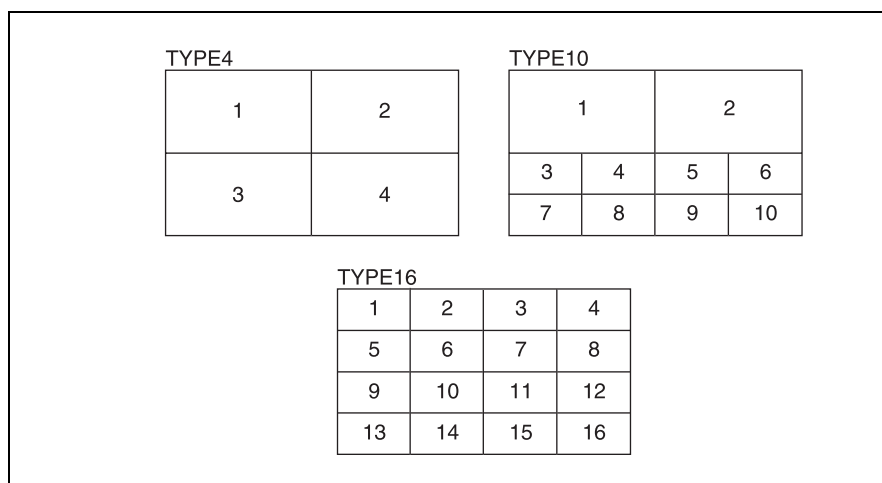

To adjust the display positions and sizes of child window titles

- 1** Carry out steps **1** to **6** of the procedure in “Changing signal display names” (*page 74*) to load a list file output by the control panel (dfs900.ini) into a computer.
- 2** Use Notepad or another text editor to edit the parameter values (the values after the equals signs) in the [MVParam] section of the dfs900.ini file.

Parameter	Description	Setting values
LargeOffsetV	Specifies the vertical display position in large child windows.	0 to 50
LargeOffsetH	Specifies the horizontal display position in large child windows.	0 to 50
LargeWidth	Specifies the display width in large child windows.	0 to 50

Parameter	Description	Setting values
LargeHeight	Specifies the height of characters in large child windows.	0 to 50
SmallOffsetV	Specifies the vertical display position in small child windows.	0 to 25
SmallOffsetH	Specifies the horizontal display position in small child windows.	0 to 25
SmallWidth	Specifies the display width in small child windows.	0 to 25
SmallHeight	Specifies the height in characters in small child windows.	0 to 25
HalfMatte	Specifies whether to add a background (half matte black rectangle) behind signal name displays.	ON: Add background OFF: Do not add background

Note

The settings made here are applied to all child windows of the same size. It is not possible to specify display positions for individual child windows.

Title display positions and parameter values

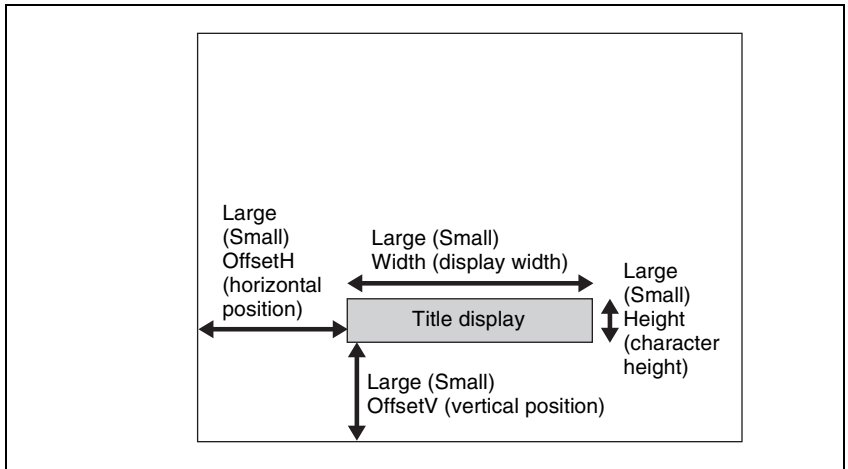

- 3** After editing the file parameters, save the file back to the USB flash drive (overwriting the old file), and then insert the flash drive into the USB MEMORY connector again.
- 4** Carry out steps **2** to **4** of the procedure in “Changing signal display names” to display the Signal sub menu, and then hold the F4 knob down for one second or longer.

The updated file is loaded into the switcher.

Note

The above operations alone do not cause child window titles to be displayed. Continue by carrying out step **5** below.

- 5** Carry out steps **1** to **3** of the procedure in “To specify the partition type and assign output video to child windows” (page 97) to display the MV1 or MV2 sub menu, and then carry out step **8** to turn the display of child window titles on.

To add frames to child windows

You can add frames to child windows to indicate that the signal assigned to a child window is program or preview output or a component element of program or preview output (the currently selected input, a key signal, and so on).

Tips

- The factory default frame color settings are as follows.

Child window output	Frame color
Program output, and components of program output	Red
Preview output, and components of preview output	Green

- When program output and preview output share the same component elements, the frame color for program output takes priority.

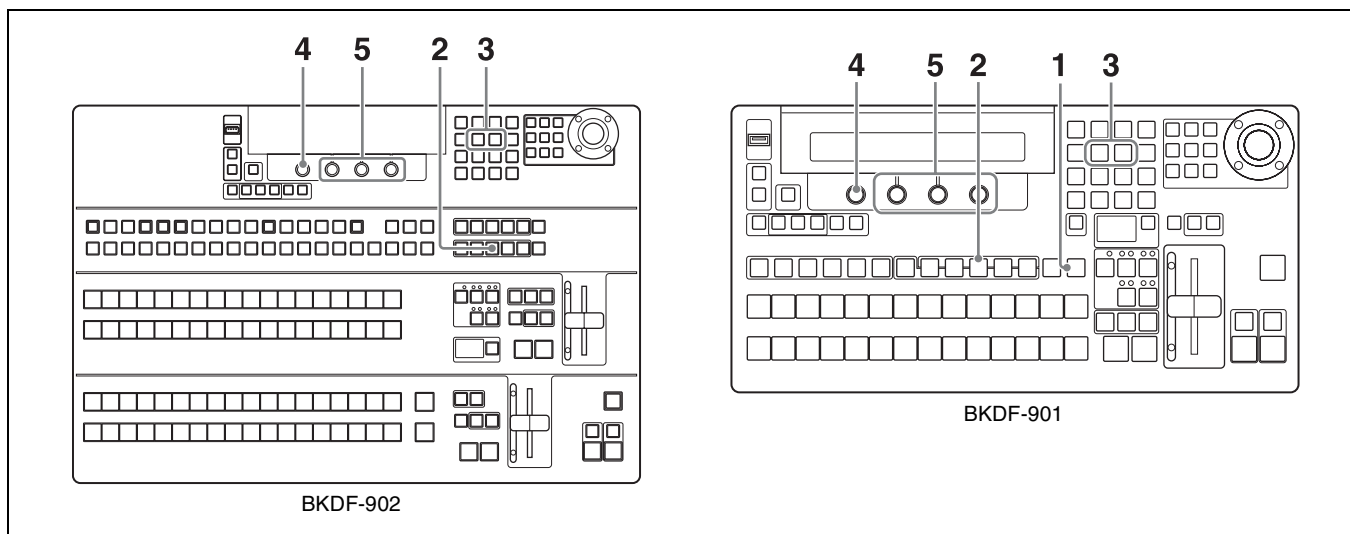

1 When using the BKDF-901: If the SHIFT button of the DME/SETUP block is not lit, press it to light it.

When using the BKDF-902: Skip to step 2.

2 Press the MV button.

A settings sub menu of the MV (multi-view output settings) sub menu appears in the display panel.

3 Press the ◀ or ▶ button in the numeric keypad until one of the following status sub menus appears, for one of the types of windows to which frames can be added.

If the sub menu that you want is already displayed, you can skip this step.

Name displayed in sub menu title display area	Description
MV1 OA Tally	Among the multi-view child windows displayed by a BKDF-950 connected to MV1 socket, display a frame around windows that display the current On Air program output, or component elements of that output.

Name displayed in sub menu title display area	Description
MV1 Next Tally	Among the multi-view child windows displayed by a BKDF-950 connected to MV1 socket, display a frame around windows that display the video to be sent to program output next, or component elements of that output.
MV2 OA Tally	Among the multi-view child windows displayed by a BKDF-950 connected to MV2 socket, display a frame around windows that display the current On Air program output, or component elements of that output.
MV2 Next Tally	Among the multi-view child windows displayed by a BKDF-950 connected to MV2 socket, display a frame around windows that display the video to be sent to program output next, or component elements of that output.

Example with MV1 OA Tally displayed:

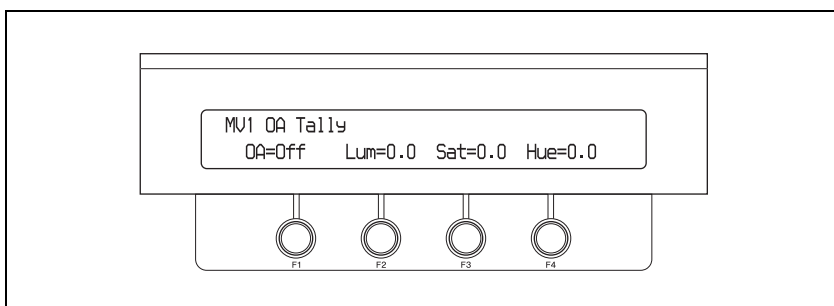

Example with MV1 Next Tally displayed:

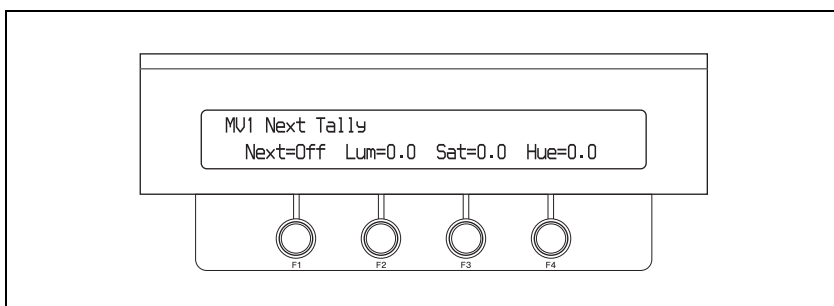

- 4** Rotate the F1 knob to specify whether to add a frame.

Off: Do not add a frame.

On: Add a frame.

- 5** Rotate F2, F3, and F4 knobs to specify the color and other properties of the frame.

The correspondence between knobs and parameters is as follows.

Knob	Parameter	Description	Setting range
F2	Luminance	Luminance of the frame	0.0 to 108.6
F3	Saturation	Saturation of the frame	0.0 to 100
F4	Hue	Hue of the frame	0.0 to 359.5

Enabling the DSK preview function

When downstream keys are off, you can display them in the preview window (DSK preview function).

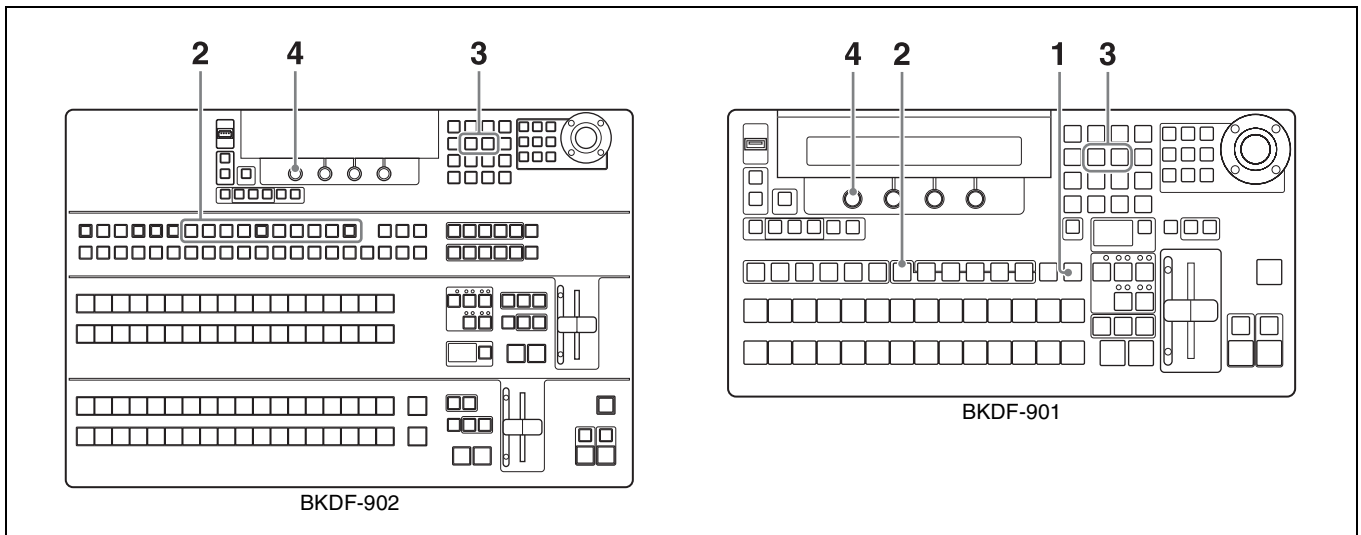

1 When using the **BKDF-901**: If the SHIFT button of the DME/SETUP block is not lit, press it to light it.

When using the **BKDF-902**: Skip to step 2.

2 When using the **BKDF-901**: Press the AUX button.

When using the **BKDF-902**: Press on of the AUX1 to AUX10 buttons.

Note

When optional expansion boards are not installed, the AUX3 to AUX10 buttons are disabled.

A settings sub menu of the Aux sub menu appears in the display panel.

3 Press the \triangleright button in the numeric keypad until the Setup >Output >Other sub menu appears.

“Other” appears in the sub menu title display area. If it is already displayed there, you can skip this step.

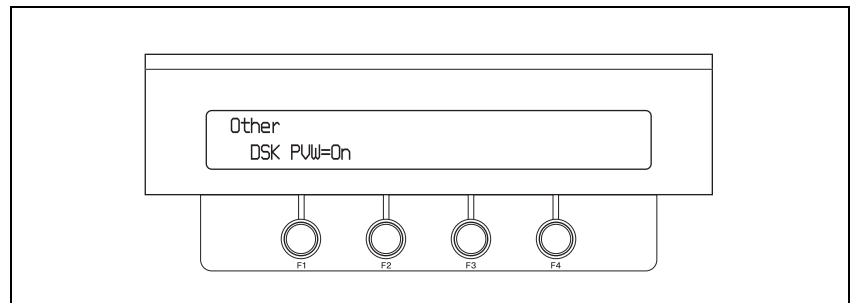

4 Rotate the F1 knob to turn the DSK preview function on or off.

On: Display downstream keys in the preview window only when downstream keys are off.

Off: Do not display downstream keys in the preview window.

Making Other Settings

Specifying the timing of video switching

You can specify whether to switch video signals on odd fields, even fields, or any field.

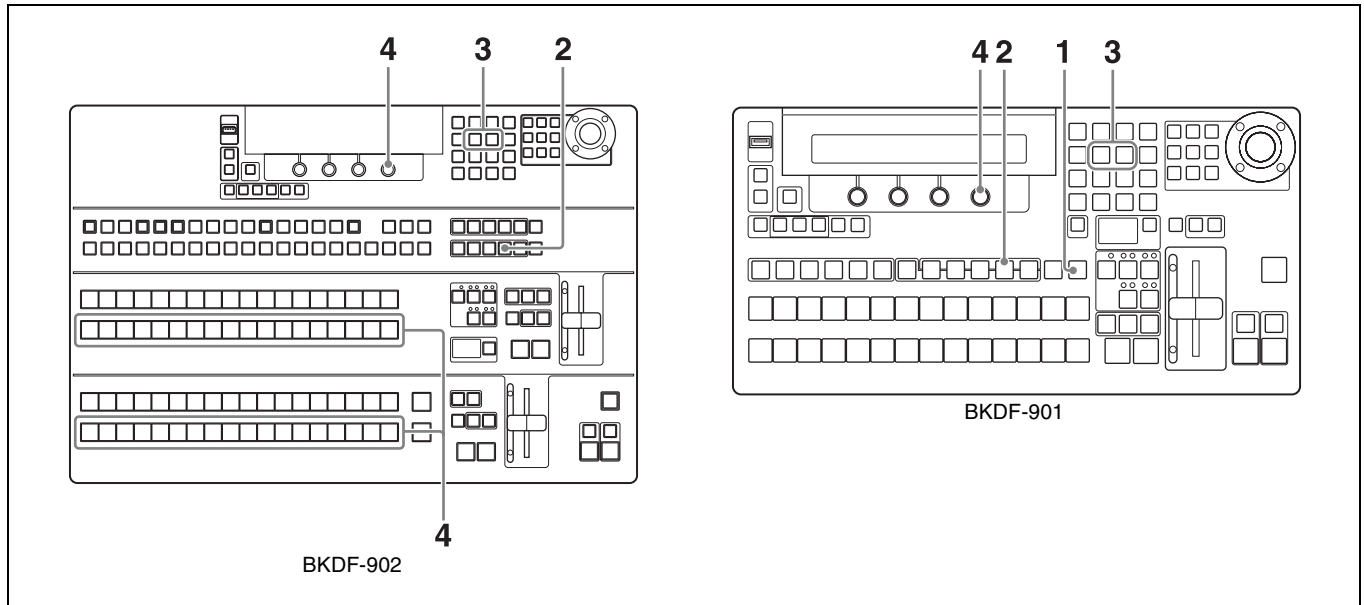

- 1** When using the **BKDF-901**: If the SHIFT button of the DME/SETUP block is not lit, press it to light it.

When using the **BKDF-902**: Skip to step 2.

- 2** Press the SYSTEM button.

A settings sub menu of the System sub menu appears in the display panel.

- 3** Press the ◀ or ▶ button in the numeric keypad until the Other sub menu appears.

“Other” appears in the sub menu title display area. If it is already displayed there, you can skip this step.

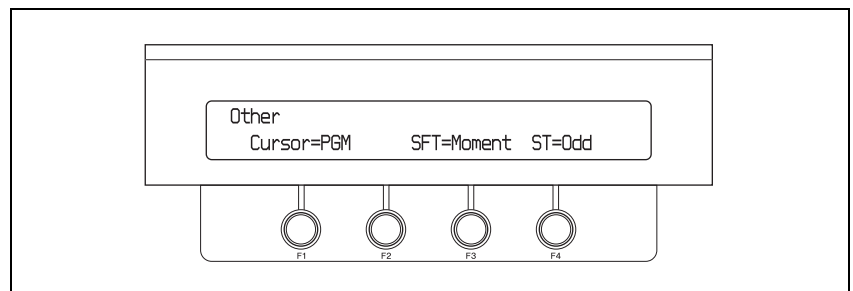

- 4** Rotate the F4 knob to select the timing of video switching.

Odd: Switch video on odd fields.

Even: Switch video on even fields.

Any: Switch video on any field.

Note

This setting is ignored when the video format setting is 720/50 or 720/59 (see page 71).

Selecting the operating mode of the SHIFT buttons

Use the following procedure to select the operating mode of the SHIFT buttons of the cross-point bus block.

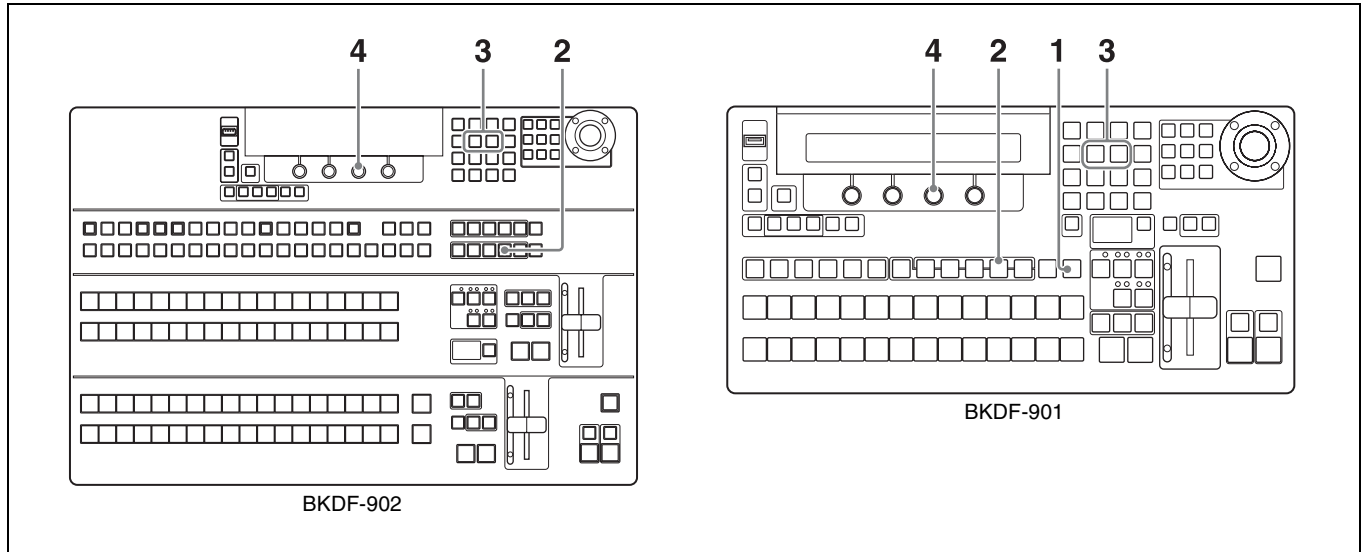

1 When using the **BKDF-901**: If the SHIFT button of the DME/SETUP block is not lit, press it to light it.

When using the BKDF-902: Skip to step 2.

2 Press the SYSTEM button.

A settings sub menu of the System sub menu appears in the display panel.

3 Press the ◀ or ▶ button in the numeric keypad until the Other sub menu appears.

“Other” appears in the sub menu title display area. If it is already displayed there, you can skip this step.

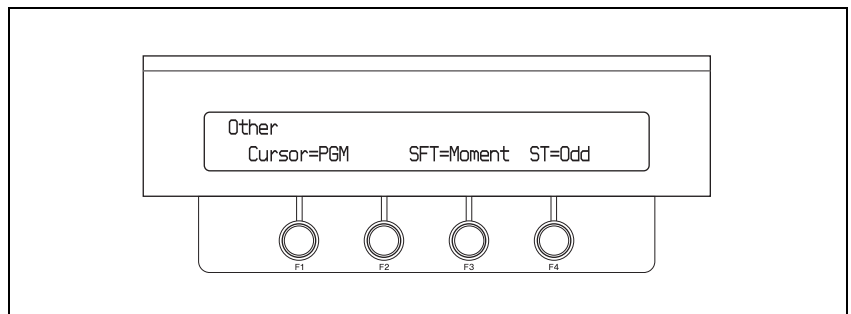

4 Rotate the F3 knob to select the timing of video switching.

Moment: Selects the SHIFT side functions assigned to buttons as long as a SHIFT button is held down.

Toggle: Each press of a SHIFT button toggles between selecting the SHIFT side and non-SHIFT side functions assigned to buttons.

Setting the Date and Time

Use the following procedure to set the date and time of the switcher's internal clock.

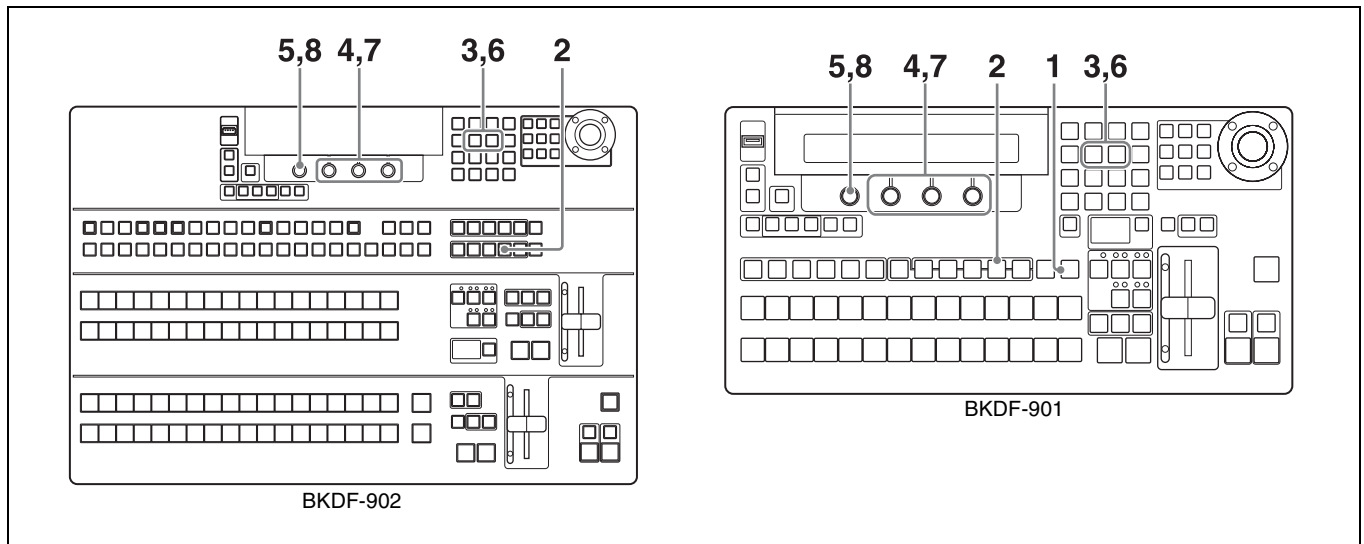

1 When using the BKDF-901: If the SHIFT button of the DME/SETUP block is not lit, press it to light it.

When using the BKDF-902: Skip to step 2.

2 Press the SYSTEM button.

A settings sub menu of the System sub menu appears in the display panel.

3 Press the ◀ or ▶ button in the numeric keypad until the Date Adj. (set date) sub menu appears.

“Date Adj.” appears in the sub menu title display area. If it is already displayed there, you can skip this step.

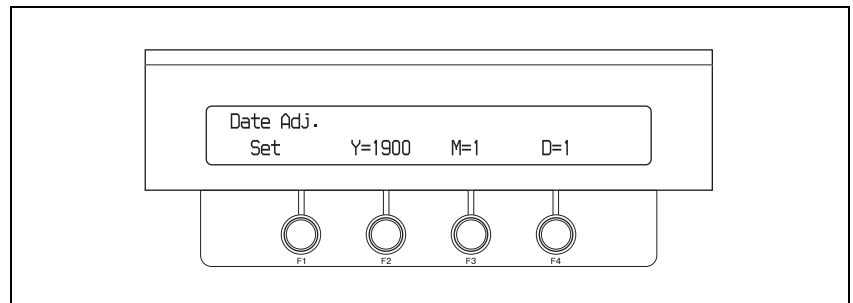

4 Rotate the F2, F3, and F4 knobs to set the year, month, and day.

The correspondence between knobs and parameters is as follows.

Knob	Parameter	Description	Setting range
F2	Y	Year	2000 to 2100
F3	M	Month	1 to 12
F4	D	Day	1 to 31

5 Hold the F1 knob down for one second or longer.

The date is set.

- 6** Press the \triangleright button once to display the Time Adj. (set time) sub menu.
 “Time Adj.” appears in the sub menu title display area.

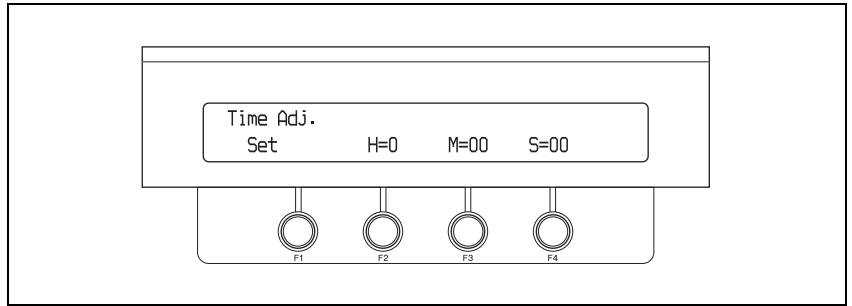

- 7** Rotate the F2, F3, and F4 knobs to set the hour, minute, and second.

The correspondence between knobs and parameters is as follows.

Knob	Parameter	Description	Setting range
F2	H	Hour	0 to 23
F3	M	Minute	0 to 59
F4	S	Second	0 to 59

- 8** Hold the F1 knob down for one second or longer.

The time is set.

Selecting Backgrounds

The output from the PGM1 and PGM2 connectors is called the “program output video”. You can check it on the program monitor and in the multi-view screen.

For more information about the multi-view screen, see “Making multi-view output settings” (page 96).

The rearmost video in program output video is the background.

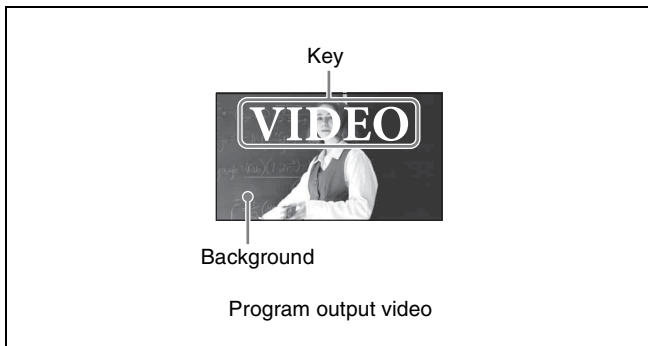

To select a background

When using the BKDF-901: Use the PROGRAM selection buttons in the cross-point bus block. From among these buttons, press the button to which the video that you want has been assigned.

When using the BKDF-902: Use the M/E bus A selection buttons in the M/E cross-point bus block, and the PROGRAM bus selection buttons and the M/E button in the PROGRAM/PRESET cross-point bus block. From among these buttons, press the button to which the video that you want has been assigned. Press the M/E button to select the video which was selected in the M/E cross-point bus block.

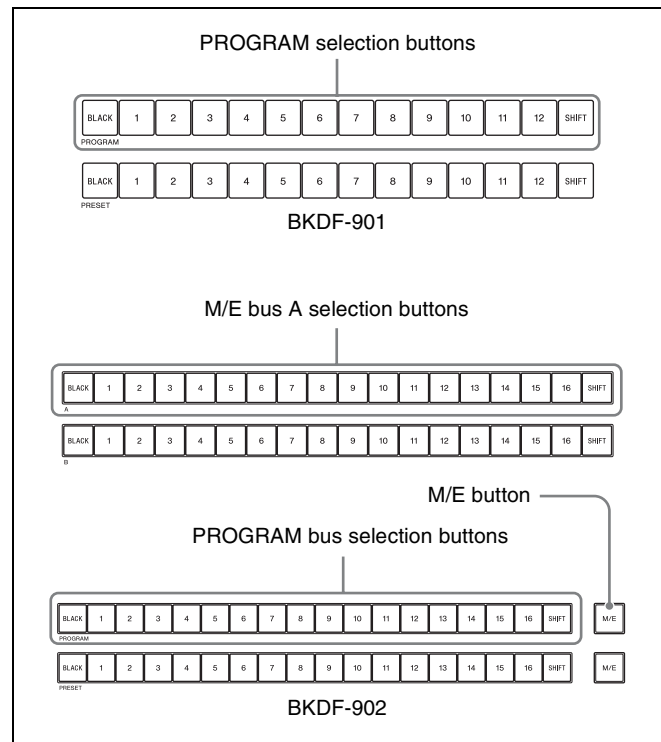

The pressed button lights in red. This indicates that the selected video is being output as the program video. In the multi-view screen, the current program output video is surrounded by a frame. When the switcher is shipped from the factory, the color of the frame is set to red.

To select the background that appears after a transition

When using the BKDF-901: Use the PRESET selection buttons in the cross-point bus block. From among these buttons, press the button to which the video that you want has been assigned.

When using the BKDF-902: Use the M/E bus B selection buttons in the M/E cross-point bus block, and the PRESET bus selection buttons and the M/E button in the PROGRAM/PRESET cross-point bus block. From among these buttons, press the button to which the video that you want has been assigned. Press the M/E button to select the video which was selected in the M/E cross-point bus block.

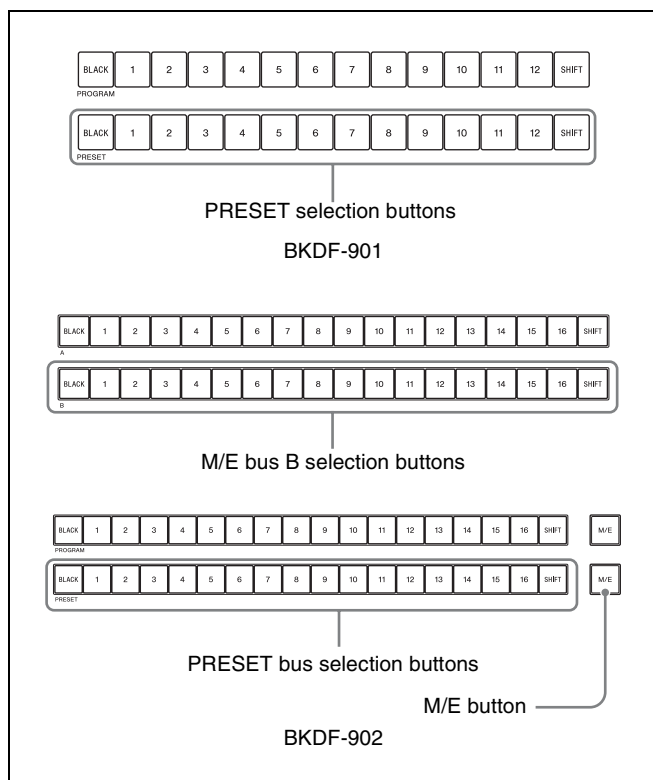

The pressed button lights in green. This indicates that the selected video is not being output from a PGM connector. In the multi-view screen, the preset video is surrounded by a frame. When the switcher is shipped from the factory, the color of the frame is set to green.

Switching Backgrounds

A replacement of one or more of the video elements that make up the current program output by another video element is called a “transition”.

Video elements include the background and keys 1 to 4. A transition can involve changes in one element or simultaneous changes in a number of elements.

There are two main types of transitions.

- Transitions in which the next video appears instantly. This type of transition is called a “cut”.
- Transitions in which the next video appears gradually over a specified time through the application of an effect. Two of the most commonly used effect types are mixes and wipes.

This section explains how to switch the background.

Cutting to a New Background

Basic cut operations

There are two ways to cut to a new background.

- Cut directly to the next background by pressing a cross-point selection button.
- Check the next background in the preview screen, and then press the CUT button.

The figure below shows the flow of cut operations.

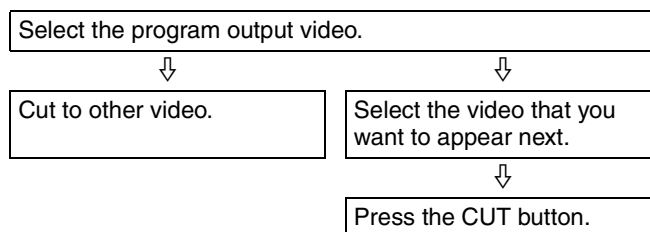

Cutting directly with the cross-point selection buttons

If you simply want to switch to other video inputs, you can press the cross-point selection buttons to which those inputs have been assigned, pressing one button after another.

Tip

By installing the optional BKDF-950 Multi Viewer Board, you can check program video, preview video, and multiple video inputs at the same time on a video monitor connected to the processor unit. This is very convenient when you select video signals.

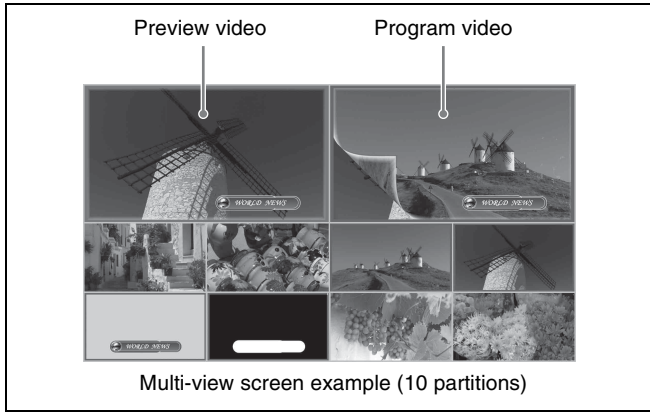

For details, see “Making multi-view output settings” (page 96).

Cutting with the CUT button after checking the next video in the preview screen

Use the CUT button to cut instantly after checking the video in the preview screen.

When using the BKDF-901

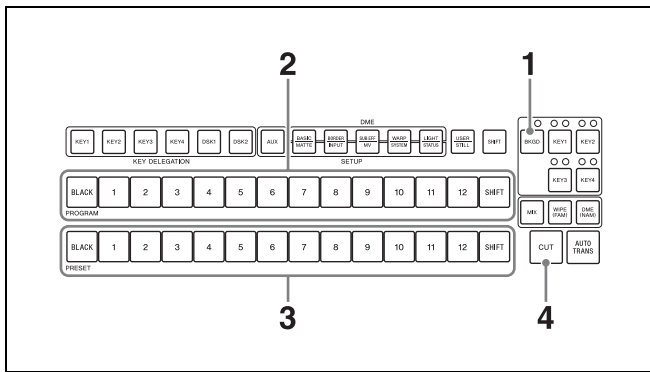

- 1** In the transition block, press the BKGD next transition selection button, lighting it.
- 2** In the cross-point bus block, press a PROGRAM selection button to select the video that appears before the cut.
The pressed button lights in red, and the selected video becomes the program output video.
- 3** Press a PRESET selection button to select the video that appears after the cut.
The pressed button lights in green, and the selected video appears in the preview screen.
- 4** Press the CUT button.
The program output and preview output video are switched instantly. The colors of the buttons in the cross-point block change to reflect the switch.

Example: When PROGRAM selection button 1 and PRESET selection button 4 are selected

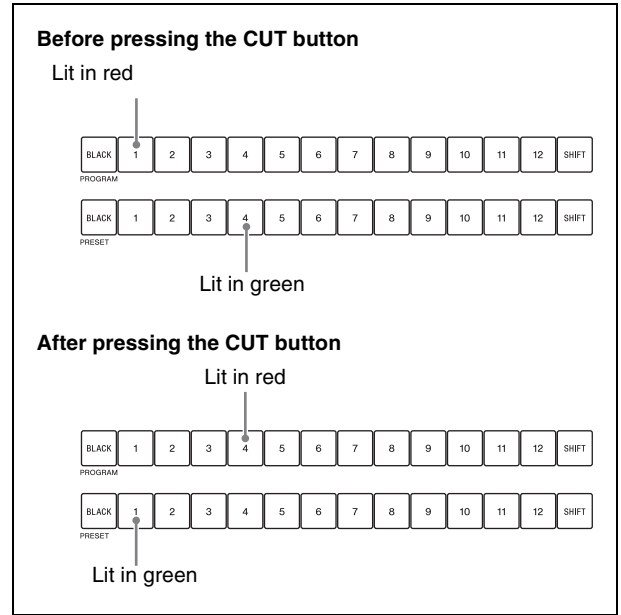

Each time the CUT button is pressed, the program output video switches between the video signals selected with the PROGRAM selection button and PRESET selection button.

When using the BKDF-902

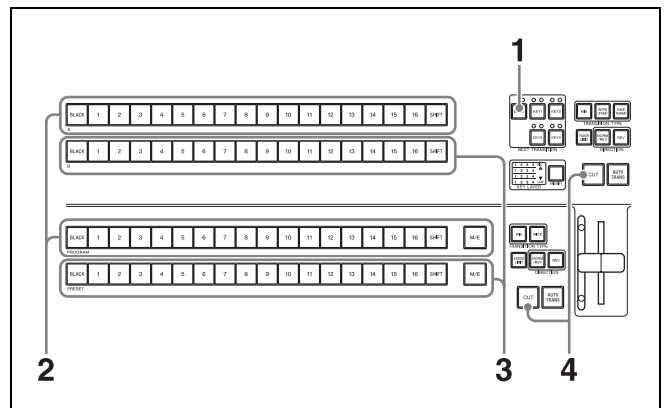

- 1** In the M/E transition block, press the BKGD next transition selection button, lighting it.
- 2** Press an M/E bus A selection button in the M/E cross-point bus block or a PROGRAM bus selection button in the PROGRAM/PRESET cross-point bus block to select the video that appears before the cut.
The pressed button lights in red, and the selected video becomes the program output video.
- 3** Press an M/E bus B selection button in the M/E cross-point bus block or a PRESET bus selection button in the PROGRAM/PRESET cross-point bus block to select the video that appears after the cut.

The pressed button lights in green, and the selected video appears in the preview screen.

4 Press the CUT button.

The program output and preview output video are switched instantly. The colors of the buttons in the cross-point block change to reflect the switch.

Example: When PROGRAM bus selection button 1 and PRESET bus selection button 4 are selected

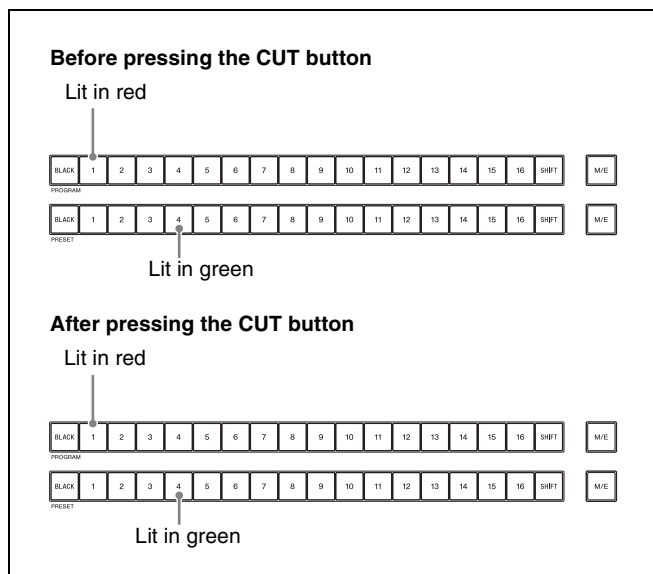

Each time the CUT button is pressed, the program output video switches between the video signals selected with the PROGRAM bus selection button and PRESET bus selection button.

Cutting by using GPI output

You can control playback timing by sending GPI signals to playback devices connected to the switcher.

For example, if you want the background to switch when display of a clip used by a key reaches full-screen display, you can proceed as follows.

For information about GPI output settings, see page 166.

1 First, in the Delay menu of the Transition sub menu, set the following parameters.

(Specify when the background switch occurs, as a number of frames after the start of clip playback.)

Knob	Parameter	Description	Settings
F1	C-Delay Rate	Cut delay time	0 to 999 (frames)
F2	AT-Delay Rate	Auto transition delay time	0 to 999 (frames)

2 Cue up the playback device.

3 While holding down the WIPE transition type selection button, press the DME button.

CG Wipe is selected

4 Turn on the key that uses the signal input from the playback device.

5 Press the CUT button.

Using Transitions to Switch to the Next Video (Mix and Wipe)

Instead of cutting instantly to the next video, you can reveal it gradually by applying a variety of video effects. This switcher provides the following two main types of transition effects.

- Effects that cause the next video to gradually appear over the original video (mix)
- Effects in which the next video wipes away the original video (wipe)

Basic transition effect operations

The figure below shows the flow of transitions that use transition effects.

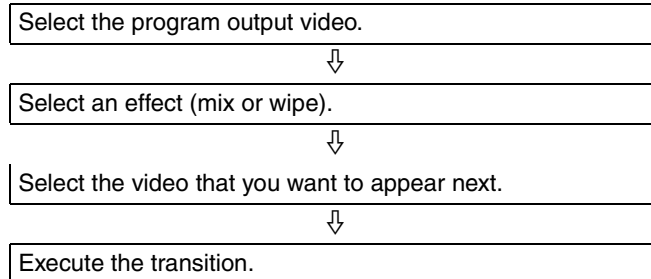

How to execute transitions

You can execute a transition by doing one of the following.

- Press the AUTO TRANS button to execute the transition automatically.
- Use the fader lever to execute the transition manually.

Buttons and controls used to execute transitions

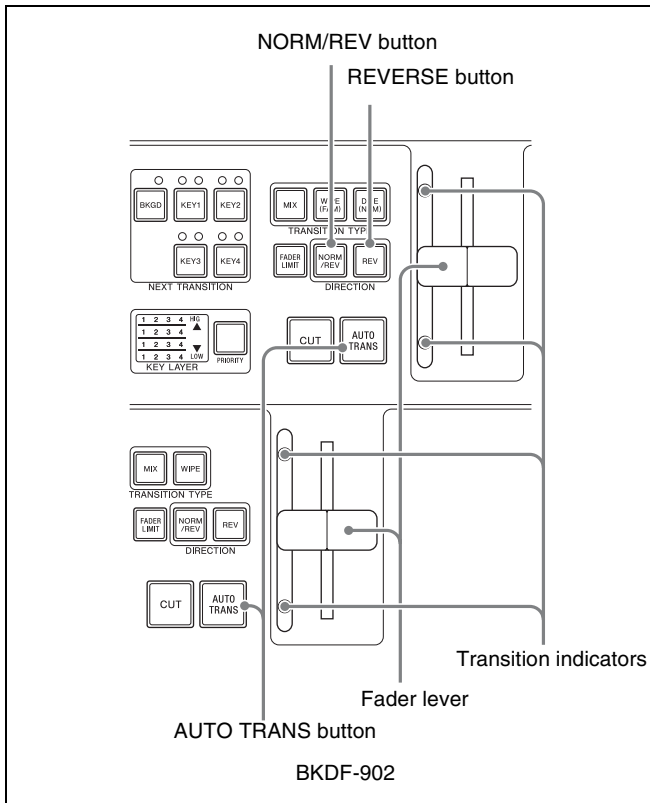
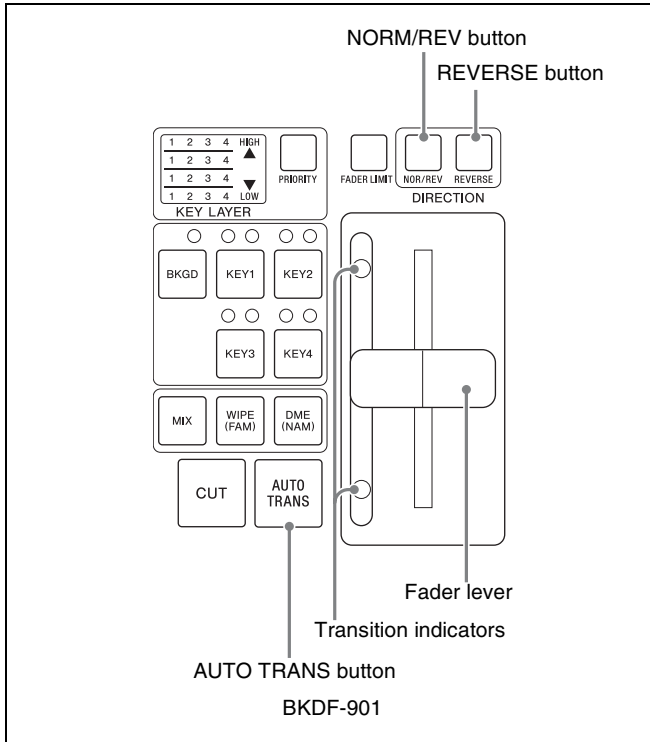

Using the AUTO TRANS buttons

After selecting the video that you want to use, press the AUTO TRANS button. The transition is executed over a time set in advance (the transition rate).

For information about how to set transition rates, see “Setting Transition Rates” (page 117).

Using the fader lever

To execute a transition, move the fader lever in the direction of the lit transition indicator (○). The transition starts, and proceeds according to the rate at which you move the lever.

When you have moved the fader lever all the way to the end of its range, the transition finishes and the transition indicator on the opposite side lights.

Reversing the directions of transitions

If the transition effect is a wipe, you can do the following to reverse the directions of transitions.

Using the REVERSE button (when using the BKDF-901) or the REV button (when using the BKDF-902)

Press the REVERSE button (when using the BKDF-901) or the REV button (when using the BKDF-902), lighting it, to cause transitions to proceed in the reverse direction. Press the button again, turning it off, to cause transitions to proceed in the normal (forward) direction.

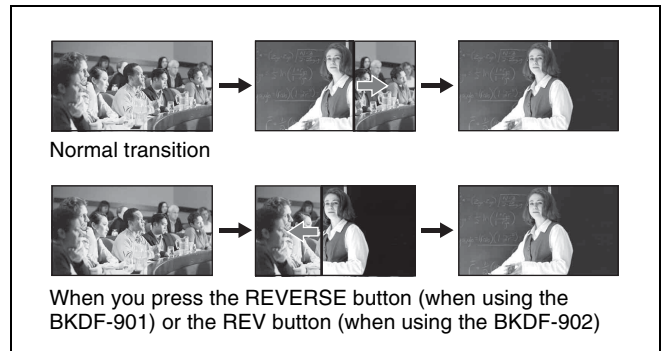

Using the NORM/REV button

Press the NORM/REV button, lighting it, to select alternating normal and reverse direction transitions. Each time a transition finishes, the direction reverses and the REVERSE (when using the BKDF-901) or the REV button (when using the BKDF-902) button lights or goes out. Press the lit NORM/REV button, turning it off, to return to transitions that always proceed in the same direction.

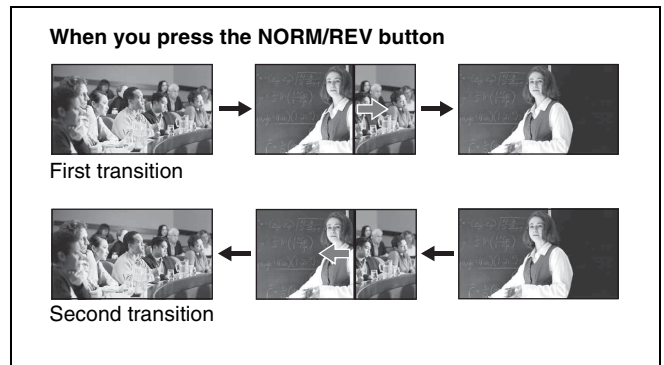

Limiting the effective range of the fader lever

You can limit the effective range of the fader lever (cause transitions to end before the fader lever reaches the top or bottom).

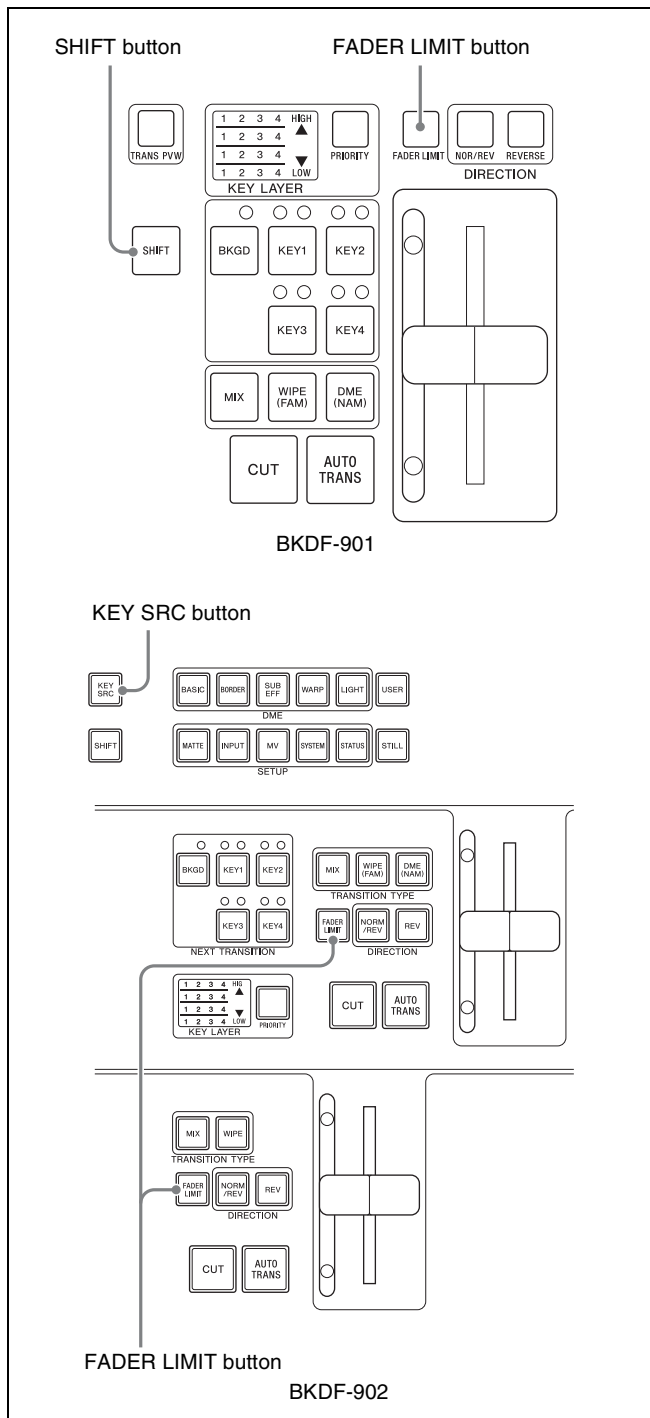

Limiting the range by using a menu

Press the FADER LIMIT button to enable the fader limit function. If you then press the FADER LIMIT button twice, the Fader Limit menu appears.

When using the BKDF-901: Rotate the F1 knob to set the limit (0.0 to 100%).

When using the BKDF-902: If you press the FADER LIMIT button in the M/E transition block, rotate the F1 knob to set the limit (0.0 to 100%). If you press the FADER LIMIT button in the PROGRAM/PRESET transition block, rotate the F2 knob to set the limit (0.0 to 100%).

Limiting the range to the desired position

When using the BKDF-901: Move the fader lever to the desired position, press the FADER LIMIT button, lighting it, and then press the SHIFT button of the DME/SETUP block, or press and hold the SHIFT button, move the fader lever to the desired position, and release the SHIFT button.

When using the BKDF-902: Press and hold the KEY SRC button, move the fader lever to the desired position, and release the KEY SRC button.

Switching with Mix Transitions

Mixes are transitions in which the next video fades into the original video, finally replacing it. You can choose from among the following three types of mix transitions.



• MIX transition

This is a transition in which the original video gradually fades out while the next video gradually fades in. At the midpoint of the transition (with the fader lever at the center of its range) the output levels of the original and the next video are both 50%.

• FAM (full additive mix) transition

This is a transition in which the next video gradually fades in to cover the original video, which is unchanged at the start of the transition. At the midpoint of the transition, the output levels of the original and the next video are both 100%. Then the original video begins to gradually fade out.

• NAM (non-additive mix) transition

The output levels of the original and next video vary in the same way as FAM, but instead of adding the two video signals for output to program output, the two signals are compared and only the signal with the highest luminance level is output.

Basic mix operations

Use the following procedure to switch between video signals by using a mix.

When using the BKDF-901

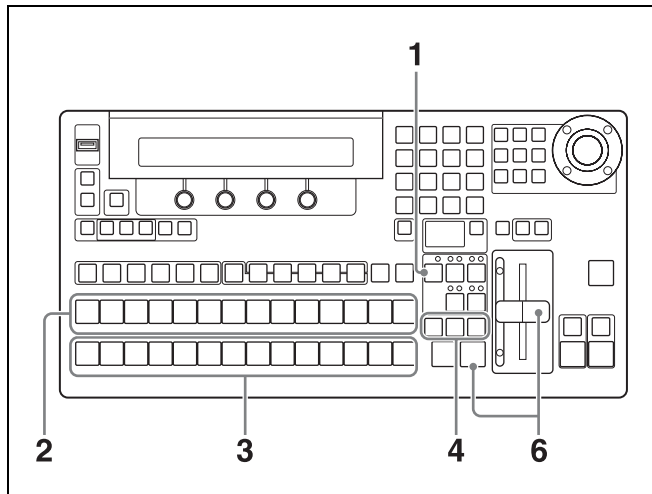

- 1** In the transition block, press the BKGD next transition selection button, lighting it.
- 2** In the cross-point bus block, press a PROGRAM selection button to select the video that appears before the transition.
- 3** In the cross-point bus block, press a PRESET selection button to select the video that appears after the transition.
- 4** Select the type of transition by pressing a transition type selection button.

MIX: Press the MIX button, lighting it.

FAM: Press the MIX button and the WIPE (FAM) button at the same time, lighting both buttons.

NAM: Press the MIX button and the DME (NAM) button at the same time, lighting both buttons.

- 5** Set the transition rate as required.

For information about how to set transition rates, see “Setting Transition Rates” (page 117).

- 6** Execute the transition by pressing an AUTO TRANS button or by moving the fader lever.

The next video is gradually mixed into the original video, and gradually replaces it.



Each time you press the AUTO TRANS button or move the fader lever, a mix transition is executed between the two currently selected video signals.

When using the BKDF-902

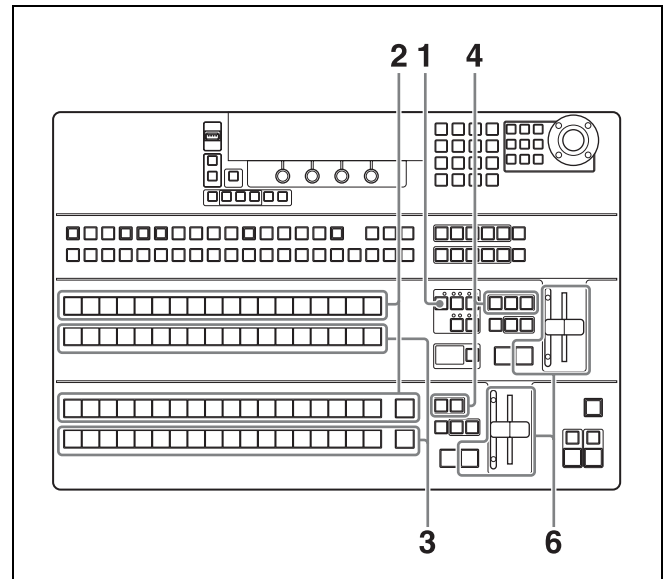

- 1** In the M/E transition block, press the BKGD next transition selection button, lighting it.
- 2** Press an M/E bus A selection button in the M/E cross-point bus block or a PROGRAM bus selection button in the PROGRAM/PRESET cross-point bus block to select the video that appears before the cut.

- 3** Press an M/E bus B selection button in the M/E cross-point bus block or a PRESET bus selection button in the PROGRAM/PRESET cross-point bus block to select the video that appears after the cut.

The pressed button lights in green, and the selected video appears in the preview screen.

- 4** Select the type of transition by pressing a transition type selection button.

MIX: Press the MIX button, lighting it.

FAM: Press the MIX button and the WIPE (FAM) button at the same time, lighting both buttons.

NAM: Press the MIX button and the DME (NAM) button at the same time, lighting both buttons.

- 5** Set the transition rate as required.

For information about how to set transition rates, see “Setting Transition Rates” (page 117).

- 6** Execute the transition by pressing an AUTO TRANS button or by moving the fader lever.

The next video is gradually mixed into the original video, and gradually replaces it.



Each time you press the AUTO TRANS button or move the fader lever, a mix transition is executed between the two currently selected video signals.

Switching with Wipe and DME Wipe Transitions

Wipes are transitions in which the next video gradually wipes away the original video. There are 98 different wipe patterns which specify how the original video is wiped away, in addition to 231 patterns created with DME effects (DME wipe patterns).



For details, see “Wipe” (page 189) and “DME Wipe” (page 192).

Basic wipe and DME wipe operations

Use the following procedure to switch between video signals by using a wipe.

When using the BKDF-901

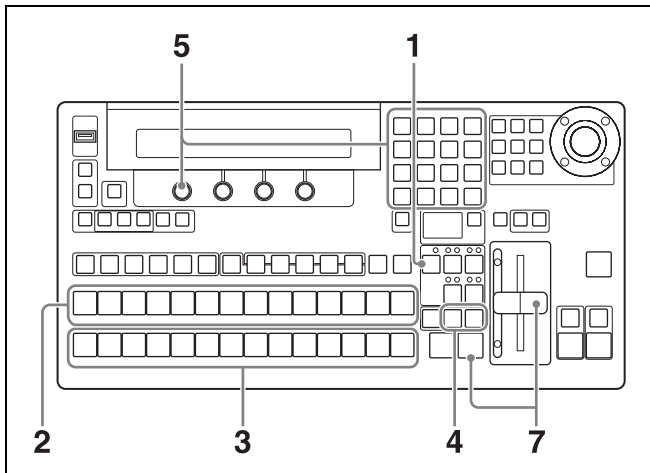

- 1 In the transition block, press the BKGD next transition selection button, lighting it.
- 2 In the cross-point bus block, press a PROGRAM selection button to select the video that appears before the transition.
- 3 In the cross-point bus block, press a PRESET selection button to select the video that appears after the transition.

- 4 Press the WIPE or DME transition type selection button, lighting it.

The WIPE menu or the DME menu appears in the display panel.

WIPE menu

```
Wipe Pattern
Pat=0 Wid=9.1 Soft=12.5 Src=W.Bd
```

DME menu

```
M/E DME Pattern
Pat=0
```

Note

DME must be enabled to use DME wipe patterns. Pressing the DME button when DME is not enabled has no effect. To enable and disable DME, press the DME ENABLE button (see page 14) in the KEYER block.

- 5 Rotate the F1 knob to select a wipe pattern or DME wipe pattern.

To select by entering a pattern number, press the F1 knob, enter the number in the numeric keypad, and then press the ENTER button.

For pattern numbers, see “Pattern List” (page 189).

- 6 Set the transition rate as required.

For information about how to set transition rates, see “Setting Transition Rates” (page 117).

- 7 Execute the transition by pressing an AUTO TRANS button or by moving the fader lever.

According to the selected pattern, the next video gradually wipes the original video away.

Example of wipe transition with pattern :



When using the BKDF-902

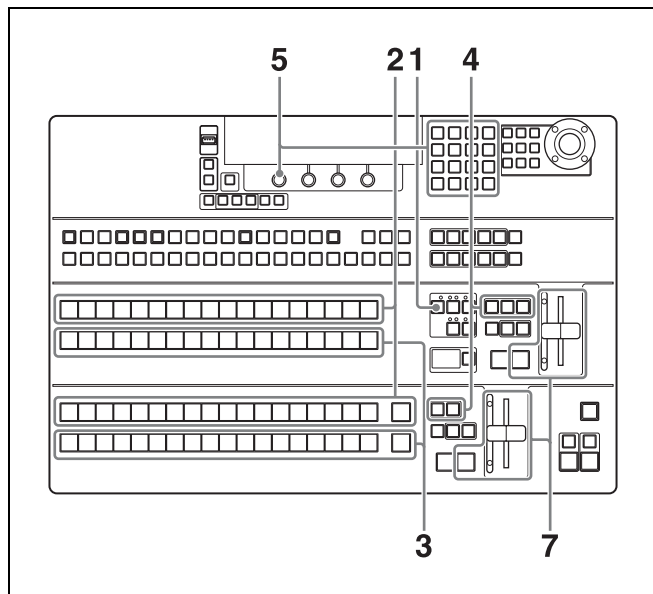

- 1** In the M/E transition block, press the BKGD next transition selection button, lighting it.
- 2** Press an M/E bus A selection button in the M/E cross-point bus block or a PROGRAM bus selection button in the PROGRAM/PRESET cross-point bus block to select the video that appears before the cut.
- 3** Press an M/E bus B selection button in the M/E cross-point bus block or a PRESET bus selection button in the PROGRAM/PRESET cross-point bus block to select the video that appears after the cut.

The pressed button lights in green, and the selected video appears in the preview screen.
- 4** In the M/E transition block, press the WIPE or DME transition type selection button, lighting it. Or in the PROGRAM/PRESET transition block, press the WIPE transition type selection button, lighting it.

When the WIPE button of the M/E transition block is pressed, the M/E WIPE menu appears in the display panel.

M/E WIPE menu

```
M/E Wipe Pattern
Pat=0 Wid=9.1 Soft=12.5 Src=W.Bd
```

When the DME button is pressed, the DME menu appears in the display panel.

DME menu

```
M/E DME Pattern
Pat=0
```

When the WIPE button of the PROGRAM/PRESET transition block is pressed, the P/P WIPE menu appears in the display panel.

P/P WIPE menu

```
P/P Wipe Pattern
Pat=0 Wid=9.1 Soft=12.5 Src=W.Bd
```

Note

DME must be enabled to use DME wipe patterns. Pressing the DME button when DME is not enabled has no effect. To enable and disable DME, press the DME ENABLE button (*see page 14*) in the KEYSER block.

- 5** Rotate the F1 knob to select a wipe pattern or DME pattern.

To select by entering a pattern number, press the F1 knob, enter the number in the numeric keypad, and then press the ENTER button.

For pattern numbers, see “Pattern List” (page 189).

- 6** Set the transition rate as required.

For information about how to set transition rates, see “Setting Transition Rates” (page 117).

- 7** Execute the transition by pressing an AUTO TRANS button or by moving the fader lever.

According to the selected pattern, the next video gradually wipes the original video away.

Example of wipe transition with pattern



Tips

- Unlike mixes, wipes and DME wipes allow the direction of the transition to be set.

For details, see “Reversing the directions of transitions” (page 112).

- You can adjust wipe and DME wipe patterns.

For details, see “Adjusting Wipes and Keys” (page 132).

Setting Transition Rates

Transition rates specify the time required to complete a transition after an AUTO TRANS button is pressed. You can set the desired transition rate across the range 1 to 999 frames.

- 1 **When using the BKDF-901:** In the transition block, press the MIX transition type selection button.

When using the BKDF-902: In the M/E or PROGRAM/PRESET transition block, press the MIX transition type selection button.

The Rate menu appears in the display panel.

Rate menu

Rate	PGM=30 DSK=30 FTB=30
------	----------------------

- 2 Rotate the F2, F3 or F4 knob to change the corresponding transition rate.

When using the BKDF-901

Knob	Parameter	Description	Settings
F2	PGM	Transition rate for background transitions and key transitions	1 to 999
F3	DSK	Transition rate for downstream key transitions (see page 130)	1 to 999
F4	FTB	Transition rate for fade to black transitions (see page 131)	1 to 999

When using the BKDF-902

Knob	Parameter	Description	Settings
F1	ME	Transition rate for background transitions and key transitions	1 to 999
F2	PGM	Transition rate for background transitions	1 to 999
F3	DSK	Transition rate for downstream key transitions (see page 130)	1 to 999
F4	FTB	Transition rate for fade to black transitions (see page 131)	1 to 999

Using Color Mattes

Video input signals are not the only signals that you can use in transitions.

You can also use the switcher's internally generated color matte signals. Up to four of these signals (Matte1 to Matte4) can be assigned to the cross-point selection buttons, allowing you to use them as backgrounds, in keys, and as modifiers. You can change the colors of these color matte signals.

Assigning Color Mattes to Cross-Point Selection Buttons

Use the menu system to assign color mattes to the desired buttons.

For details, see "Assigning video input signals to cross-point selection buttons" (page 76).

Changing the Colors of Color Mattes

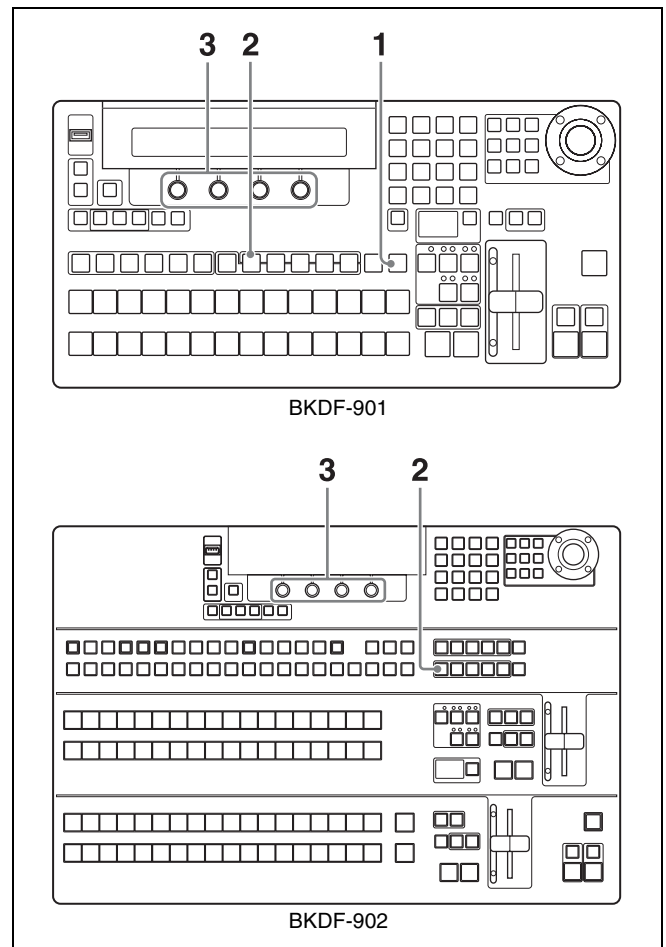

1 When using the BKDF-901: If the SHIFT button in the DME/SETUP block is not lit, press it to light it.

When using the BKDF-902: Skip to step 2.

2 Press the MATTE button.

The Matte Color menu appears in the display panel.

Matte Color menu

Matte Color
Matte 1 Lum=100.0 Sat=100.0 Hue=263.5

3 Rotate the F1 knob to select a matte signal (Matte1 to Matte4), and then rotate the F2, F3, and F4 knobs to adjust the color.

Knob	Parameter	Description	Settings
F2	Lum	Luminance	0.0 to 108.6
F3	Sat	Saturation	0.0 to 100.0
F4	Hue	Hue	0.0 to 359.5

Using Color Mattes in Background Transitions

Color mattes can be used in background transitions in the same way as video signals input to the switcher.

Select the cross-point selection button to which the desired color matte signal has been assigned, and then execute the transition.

For details about how to execute background transitions, see “Switching Backgrounds” (page 109).

Using Internally Stored Still Images

The switcher is equipped with internal memory for the storage of still image files. You can use images stored in this memory in transitions and compositions.

Tip

The supported still image file formats include 24-bit JPG (jpeg) and BMP (bitmap), TGA (targa), and 32-bit TGA (targa).

Acquiring Still Image Files

You can acquire still image files by downloading them from a USB flash drive, or by capturing program output into image files (up to 100 files).

Downloading still images from USB flash drives

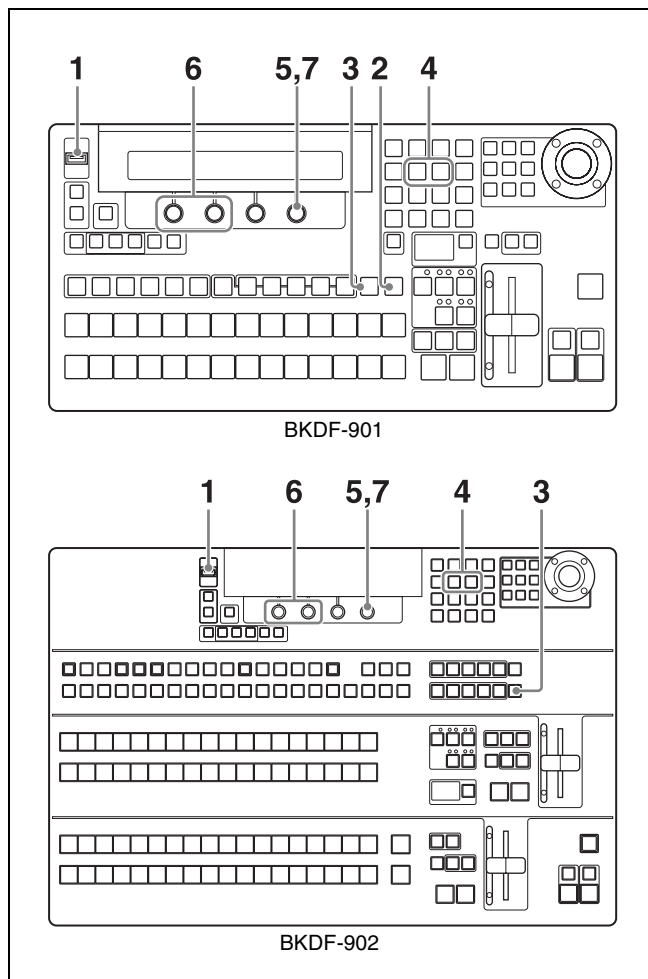

- 1 Store the images that you want to use on a USB flash drive, and connect the USB flash drive to the USB MEMORY connector.

Note

The supported file formats are 24-bit JPG (jpeg) and BMP (bitmap), TGA (targa), and 32-bit TGA (targa). Before starting, create a folder name “Stl” in the root directory of the USB flash drive. Copy the files that you want to use to that folder, assigning names in the format “stl**” (where ** is a number from 00 to 99).

- 2 **When using the BKDF-901:** If the SHIFT button in the DME/SETUP block is not lit, press it to light it.

When using the BKDF-902: Skip to step 3.

- 3 Press the STILL button.

The Still Store menu appears in the display panel.

- 4 Use the ◀ and ▶ buttons in the numeric keypad to switch to the Download sub menu.

- 5 Rotate the F4 knob to specify USB as the download source.

- 6 Set the parameters.

Knob	Parameter	Description	Settings
F1	Dst	Storage destination ^{a)}	IN01 to IN24, STL1 to STL4
F2	File	File number ^{b)}	00 to 99

a) To output still images that have been downloaded to IN01 to IN24, the corresponding frame synchronizers must be enabled. Selection of IN01 to IN24 makes it impossible to select video that is input to the corresponding input connectors. For more information about how to enable frame synchronizers, see “Using the internal frame synchronizers” (page 79).

b) An asterisk (*) appears after still image files that have already been stored.

Note

If you have changed the display names of input signals and internal signals (*see page 74*), those names appear in the F1 knob operation area.

- 7 Press the F4 knob and hold it down for one second or longer.

Downloading from the USB flash drive starts. During the download, the STILL button lights in red. When the download finishes, the button returns to lit in orange.

Notes

- Still image files downloaded from USB flash drives are also stored in the non-volatile memory of the control panel.
- If you select USB with the F4 knob, thumbnail images are not displayed in GUI menu screens.

Capturing program output

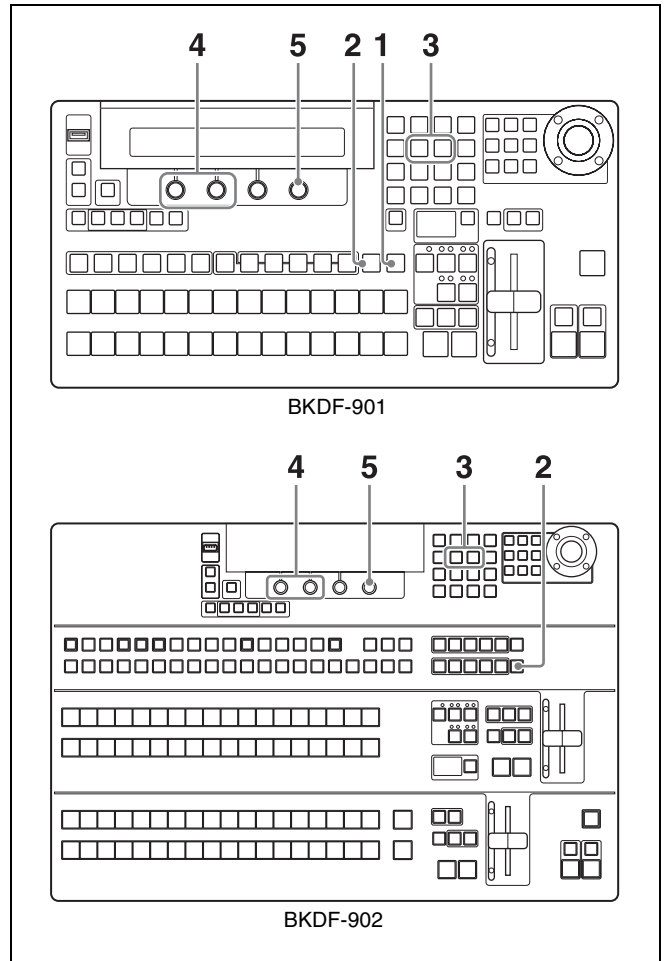

Tip

To save an input image frozen with the internal frame synchronizers, first output the image to program output and then use the procedure described below to save it to still image memory.

For details about the internal frame synchronizers, see “Using the internal frame synchronizers” (page 79).

- 1 **When using the BKDF-901:** With the video that you want to capture being output to program output, press the SHIFT button in the DME/SETUP block, lighting it.

When using the BKDF-902: With the video that you want to capture being output to program output, skip to step **2**.

- Press the STILL button.

The Still Store menu appears in the display panel.

- Use the ◀ and ▶ buttons in the numeric keypad to switch to the Image Capture sub menu.

- Set the parameters.

Knob	Parameter	Description	Settings
F1	Frz	Freeze mode	Frm: Frame Odd: Odd field Even: Even field
F2	File	File number	00 to 99

- Press the F4 knob and hold it down for one second or longer.

Capture of program output begins.

During the capture, the STILL button lights in red. When the capture finishes, the button returns to lit in orange.

Note

Captured still images are stored in the non-volatile memory of the control panel. To use still images in video transitions and compositions, they must be downloaded to still image memory.

Downloading captured still images to still image memory

- After completion of the image capture in step **5** of the previous procedure, use the ◀ and ▶ buttons in the numeric keypad to switch to the Download sub menu.
- Rotate the F4 knob to specify “CP” (control panel) as the download source.
- Set the parameters.

Knob	Parameter	Description	Settings
F1	Dst	Storage destination ^{a)}	IN01 to IN24, STL1 to STL4
F2	File	File number ^{b)}	00 to 99

a) To output still images that have been downloaded to IN01 to IN24, the corresponding frame synchronizers must be enabled. Selection of IN01 to IN24 makes it impossible to select video that is input to the corresponding input connectors. For more information about how to enable frame synchronizers see “Using the internal frame synchronizers” (page 79).

b) Select a captured image.

Note

If you have changed the display names of input signals and internal signals (see page 74), those names appear in the F1 knob operation area.

- Press the F4 knob and hold it down for one second or longer.

Downloading to the internal still image memory starts. During the download, the STILL button lights in red. When the download finishes, the button returns to lit in orange.

Using Stored Still Images in Background Transitions

Images stored in still image memory can be used in background transitions in the same way as video signals input to the switcher.

To use a stored still image, select the cross-point corresponding to the storage location (IN01 to IN24, STL1 to STL4).

For details about how to execute background transitions, see “Switching Backgrounds” (page 109).

Using 32-bit TGA Still Image Files in Keys

Tip

The 32-bit TGA format supports an α (alpha) channel for storage of additional data, such as key data. By using this format, you can store key and fill data in a single image file, which allows you to conserve still image storage memory.

- See “Downloading still images from USB flash drives” and download a 32-bit TGA file to a still image memory location (STL1 to STL4).
- Select the target key by pressing a button (KEY1 to KEY4, DSK1, DSK2) in the KEY DELEGATION block (when using the BKDF-901) or in the key/AUX bus control block (when using the BKDF-902).
- Press the EXT button in the KEYER block.
- For both the key source (KSrc) and key fill (KIns), select the still image memory location (STL1 to STL4) to which you downloaded a file in step **1**.

Note

32-bit files cannot be stored in memory locations other than STL1 to STL4.

Writing Still Images to USB Flash Drives

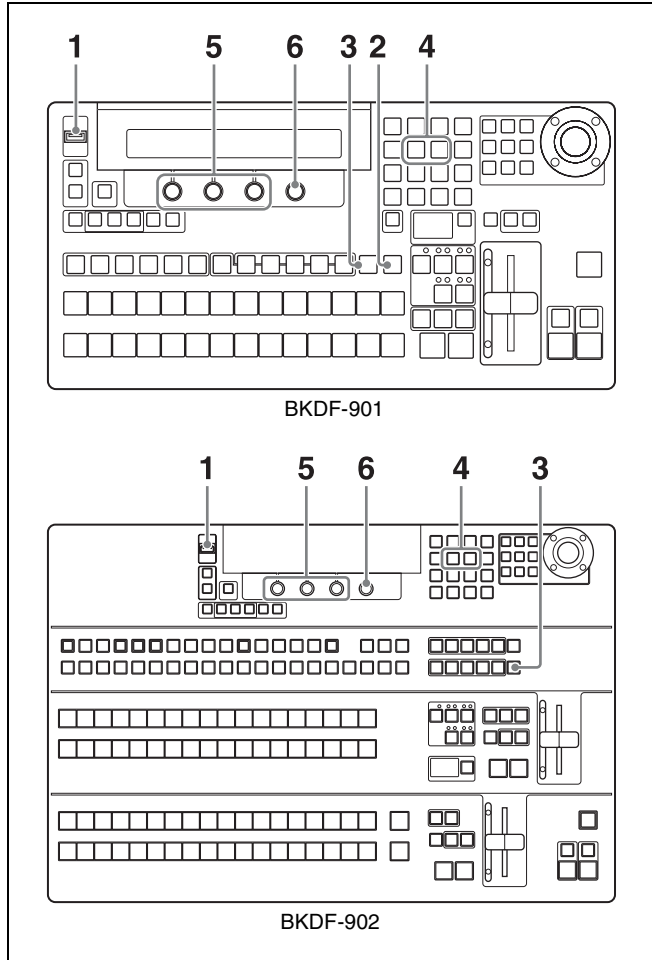

- 1** Connect the USB flash drive to which you want to store an image file to the USB MEMORY connector.
- 2** **When using the BKDF-901:** If the SHIFT button in the DME/SETUP block is not lit, press it to light it.
When using the BKDF-902: Skip to step **3**.
- 3** Press the STILL button.
The Still Store menu appears in the display panel.
- 4** Use the ◀ and ▶ buttons in the numeric keypad to switch to the Export Still sub menu.
- 5** Set the parameters.

Knob	Parameter	Description	Settings
F1	Fmt	File format	BMP, TGA
F2	File	File number	00 to 99 ^{a)}

a) “Overwrite” appears in the F3 knob operation area if a file with the same number already exists on the USB flash drive, and “New File” appears if no file with the same number exists.

- 6** Press the F4 knob and hold it down for one second or longer.

Export to the USB flash drive starts. During the download, the STILL button lights in red. When the download finishes, the button returns to lit in orange.

Tip

The exported file is stored in the Stl folder of the USB flash drive. If the Stl folder does not exist, it is created automatically.

Deleting Still Image Files

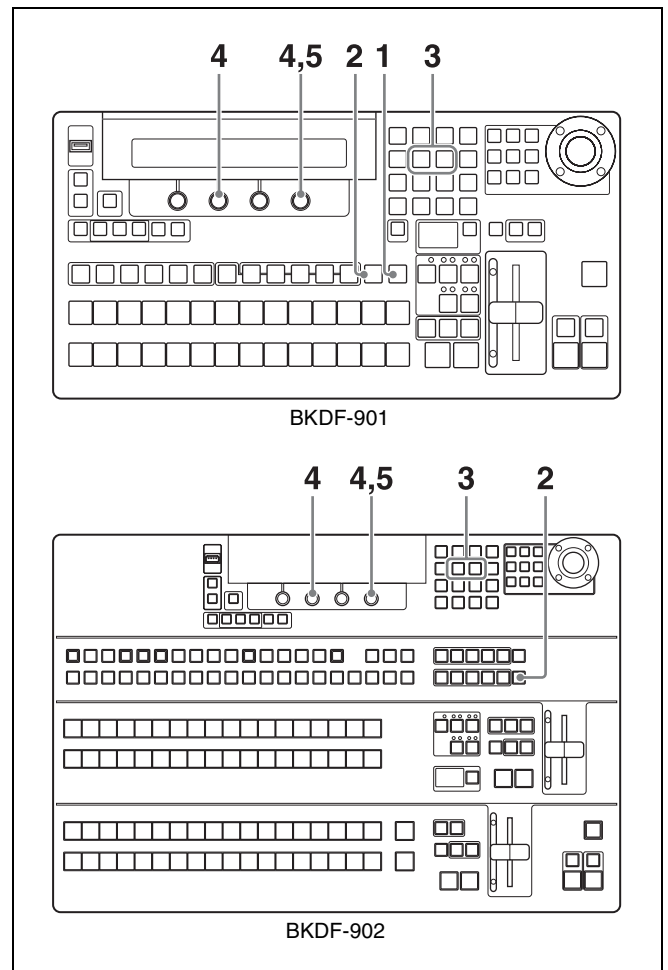

- 1** When using the **BKDF-901**: If the SHIFT button in the DME/SETUP block is not lit, press it to light it.
When using the **BKDF-902**: Skip to step **2**.
- 2** Press the STILL button.
The Still Store menu appears in the display panel.
- 3** Use the ◀ and ▶ buttons in the numeric keypad to switch to the Delete sub menu.
- 4** Set the parameters.

Knob	Parameter	Description	Settings
F2	File	File number	00 to 99
F4	Del	Storage location of the file to be deleted	CP, USB

- 5** Press the F4 knob and hold it down for one second or longer.

Deletion of the still image file begins. During the deletion, the STILL button lights in red. When the deletion finishes, the button returns to lit in orange.

Using Keys to Compose Video

This switcher allows you to add four keys (KEY1 to KEY4) and two downstream keys (DSK1 and DSK2) to the background video.

Key types

The following three key types are available on this switcher.

External keys (EXT): Keys that use separate signals for key fill and key source.

Self keys (SELF): Keys that use the same signal for key fill and key source.

Chroma keys (CK): Unlike the two keys described above, keys that are created on the basis of color data instead of luminance data. Chroma keys cannot be used with downstream keys.

Setting Up Keys

Keys and downstream keys must be set up before they can be used.

To set up external keys and self keys

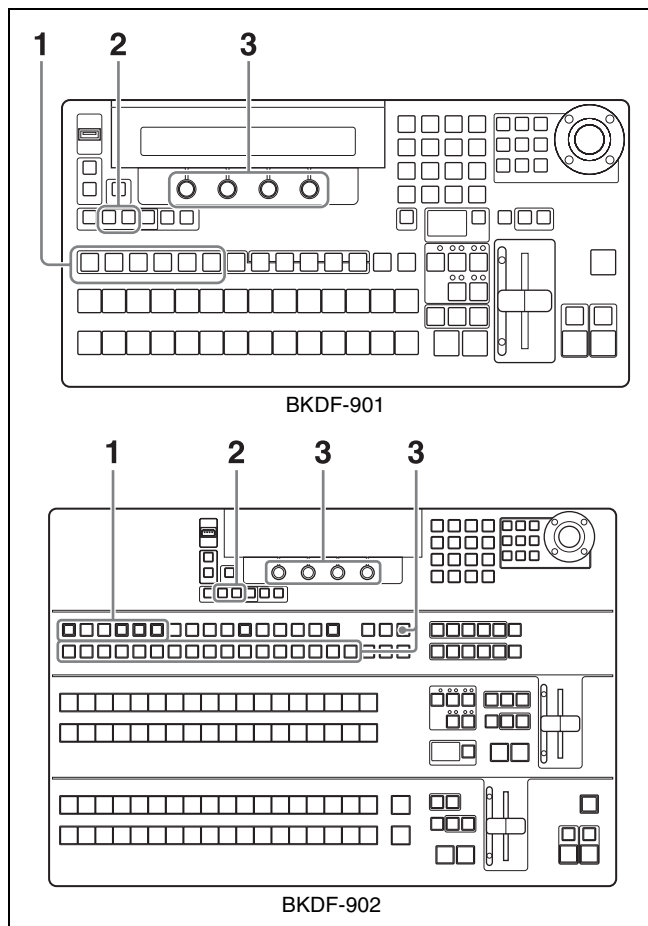

1 In the KEY DELEGATION block (when using the BKDF-901) or in the key/AUX bus control block (when using the BKDF-902), press the button for the key that you want to set up, lighting it.

2 In the KEYSER block, select the key type.

3 In the menu that appears depending on the selected key type, set the following parameters.

External (EXT) key parameters (External Key menu)

To move between parameter groups, use the ◀ and ▶ buttons in the numeric keypad.

Parameter group (1/2)

Knob	Parameter	Description	Settings
F1	KIns	Key fill	BLK, IN01 to IN24, MAT1 to MAT4, STL1 to STL4
F2	KSrc	Key source	
F3	GN	Gain	0.0 to 16.00
F4	Clp	Key reference level	0.0 to 100.0

Note

If you have changed the display names of input signals and internal signals (*see page 74*), those names appear in the F1 and F2 knob operation area.

Parameter group (2/2)

Knob	Parameter	Description	Settings
F1	Opac	Opacity	0.0 to 100.0
F2	Inv	Inverted	On, Off

Self (SELF) key parameters (Self Key menu)

To move between parameter groups, use the ◀ and ▶ buttons in the numeric keypad.

Parameter group (1/2)

Knob	Parameter	Description	Settings
F1	KIns	Key fill	BLK, IN01 to IN24, MAT1 to MAT4, STL1 to STL4
F3	GN	Gain	
F4	Clp	Key reference level	0.0 to 100.0

Note

If you have changed the display names of input signals and internal signals (*see page 74*), those names appear in the F1 knob operation area.

Parameter group (2/2)

Knob	Parameter	Description	Settings
F1	Opac	Opacity	0 to 100.0
F2	Inv	Inverted	On, Off

When using the BKDF-902, you can select key fill and key source signals for external keys by pressing the KEY SRC button.

Setting up chroma keys

A chroma key is a key that cuts out a certain part of a video signal on the basis of a specified reference color. For example, chroma keys are used to create video of foreground subjects against an arbitrary background by shooting the subjects against a blue background, extracting only the subjects for use as a key fill signal, and inserting the key fill signal into the background.

Chroma keys can be used only with KEY1 to KEY4. They cannot be used with DSK1 and DSK2.

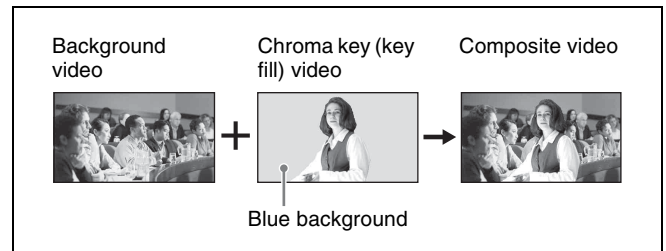

The normal procedure for creating a chroma key is to specify the color to be cut out of the video, to use an automatic switcher function to create a key fill video (auto chroma key) from the cut out video, and then to adjust that video manually.

To create an auto chroma key

Use the following procedure to create an auto chroma key.

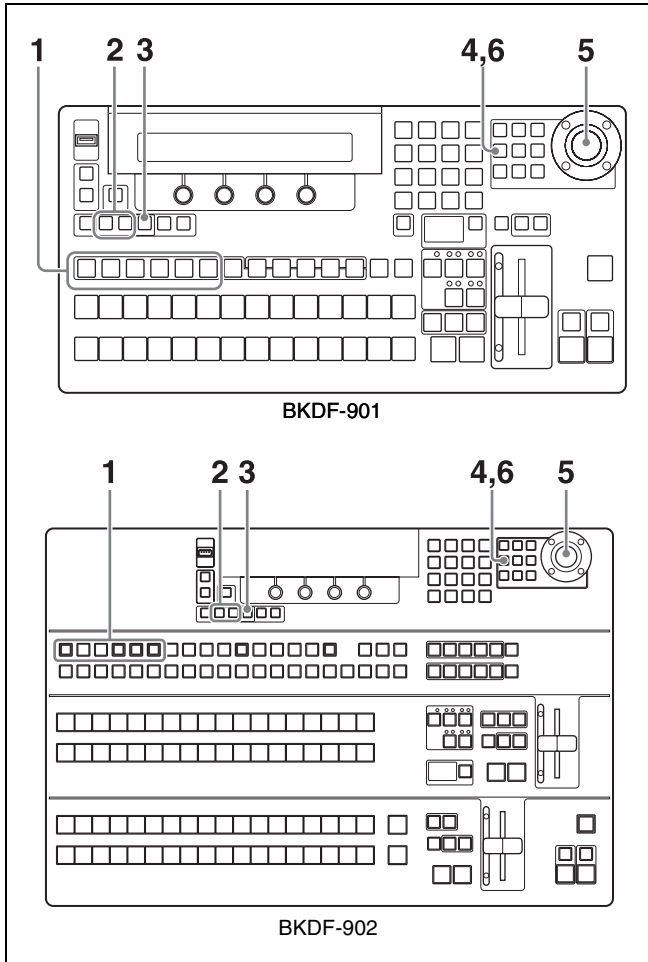

1 In the KEY DELEGATION block (when using the BKDF-901) or in the key/AUX bus control block (when using the BKDF-902), press the button for the key that you want to set up, lighting it.

2 In the KEYER block, press the EXT button or the SELF button.

When the External Key menu or Self Key menu appears, rotate the F1 knob to select the signal to use in the chroma key.

3 In the KEYER block, press the CK button.

The key type is changed to chroma key.

4 In the joystick block, press the AUTO CK button.

The switcher enters auto chroma key mode, and the CK Auto menu appears in the display panel. At the same time, a cross cursor appears in the preview or program output video.

Tip

You can reselect the signal to use in the chroma key by rotating the F1 knob.

5 Using the joystick, move the cross cursor to the color that you want to cut out (keying color).

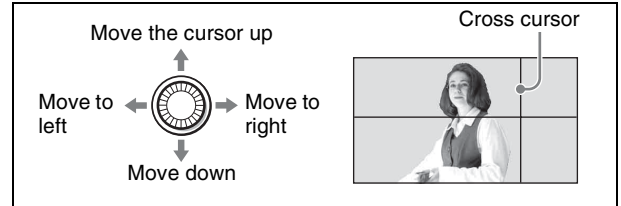

Tip

Instead of using the joystick, you can also use the F2 and F3 knobs to adjust.

6 Press the AUTO CK button.

An auto chroma key is created.

To adjust an auto chroma key

After creating an auto chroma key as explained above, use the following procedure to adjust it.

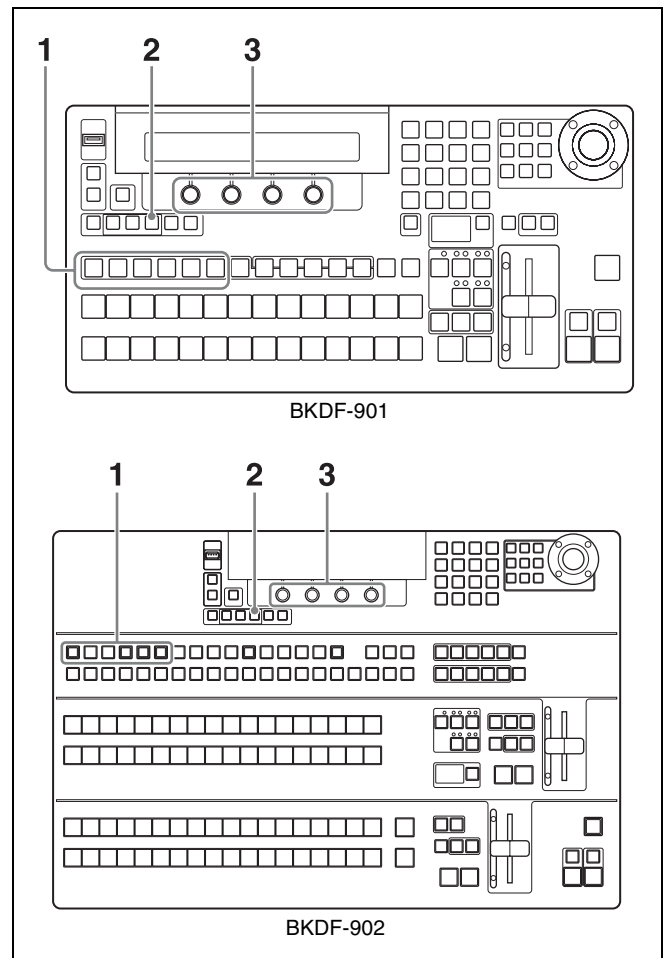

1 In the KEY DELEGATION block (when using the BKDF-901) or in the key/AUX bus control block (when using the BKDF-902), press the button that you used to create the auto chroma key, lighting it.

2 In the KEYER block, press the CK button.

A CK Manual sub menu appears in the display panel.

3 Adjust the parameters.

Chroma key (CK) parameters (Chroma Key menu)

When viewed on a vectorscope, the part of the foreground that becomes the key signal (the part that is replaced by the background) appears as a fan shaped area centered around the keying color (see the following figure).

You can adjust the shape of this area by adjusting the Angle parameter. You can also adjust the Y, C, and key signals individually.

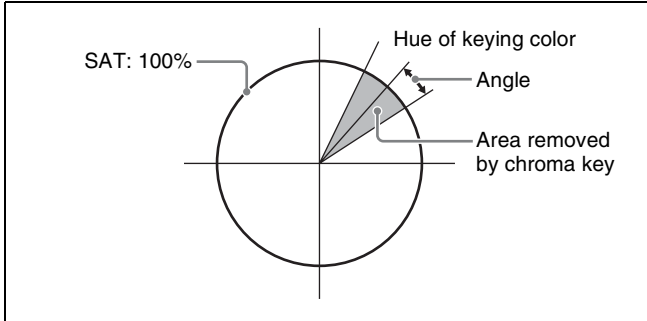

When there are patches of the background color in the foreground picture, you can remove those patches from the foreground picture (color cancel function). You can suppress the Y component of the video, and also use two parameters (C1 and C2) to adjust the chroma components (see figures below).

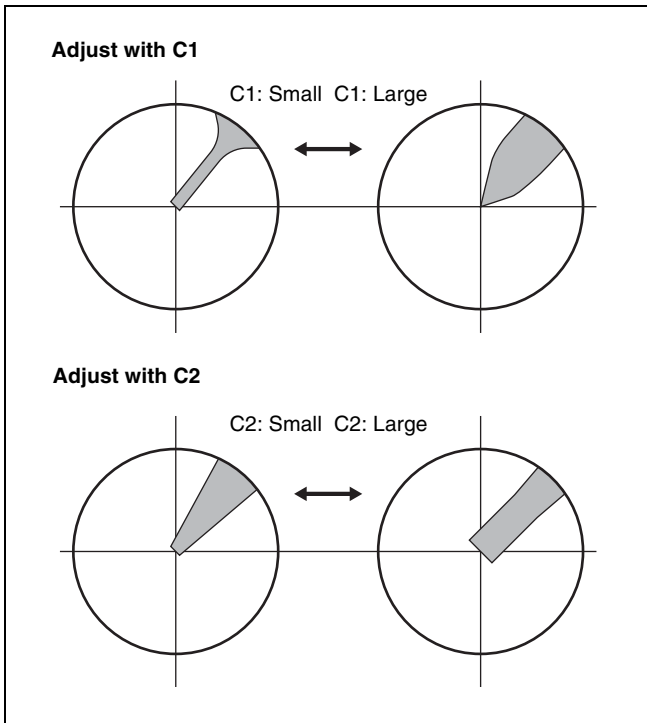

Parameter group (1/4)

Knob	Parameter	Description	Settings
F2	Hue	Keying color hue	0.0 to 359.5
F3	GN	Gain	0.0 to 63.99
F4	Clp	Key reference level	0.0 to 100.0

Parameter group (2/4)

Knob	Parameter	Description	Settings
F1	Y	Offset value vs. Angle ^{a) b)}	-45.00 to 45.00
F2	C	Offset value vs. Angle ^{a) c)}	-45.00 to 45.00
F3	K	Offset value vs. Angle ^{d)}	-45.00 to 45.00
F4	Ang	Angle of the area that becomes the key signal (Angle)	5.00 to 90.00

a) Enabled only when Color cancel is set to On.

b) Affects only Y signal of foreground video.

c) Affects only C signals of foreground video.

d) Affects only key signals.

Parameter group (3/4)

Knob	Parameter	Description	Settings
F1	Col	Color cancel	On/Off
F2	Y	Suppression of Y component	0.00 to 31.99
F3	C1	Suppression by C1 parameter ^{a)}	0.00 to 31.99
F4	C2	Suppression by C2 parameter	0.0 to 100.0

a) The C1 setting is ignored when C2 is anything other than 0.00.

Parameter group (4/4)

Knob	Parameter	Description	Settings
F1	ShL	Positional adjustment of left side of key signal	0 to 3
F2	ShR	Positional adjustment of right side of key signal	0 to 3

To adjust key opacity

Use the Other sub menu to adjust the opacity of chroma keys.

The Other sub menu has the following parameter.

Knob	Parameter	Description	Settings
F1	Opac	Opacity	0.0 to 100.0

To set the chroma key cursor

Use the following procedure to specify whether the chroma key cursor should be displayed in the program screen or the preview screen.

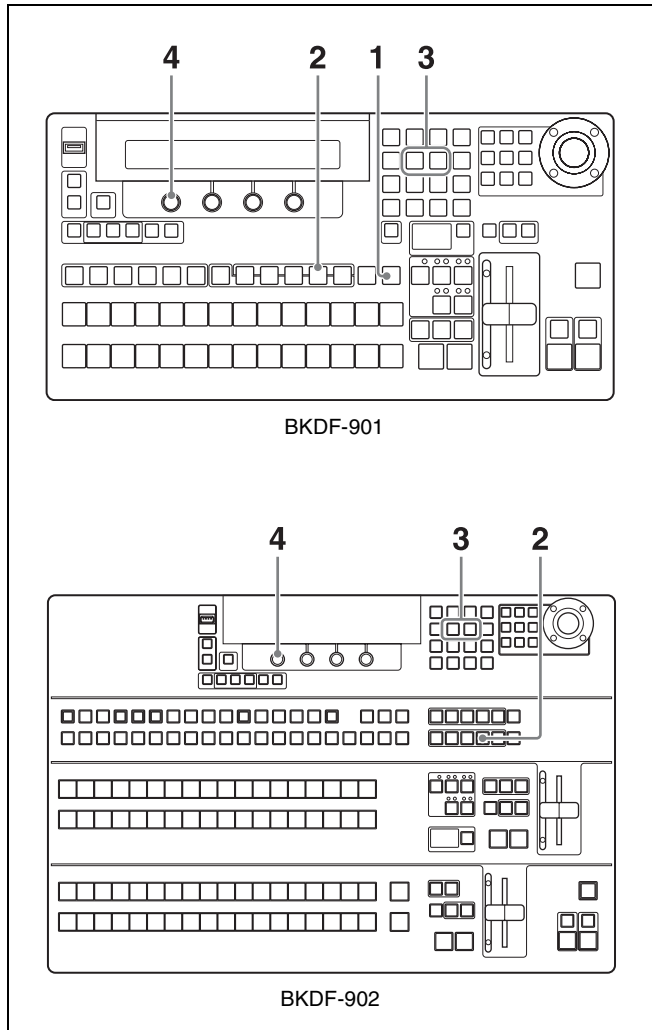

- 1** When using the **BKDF-901**: If the SHIFT button of the DME/SETUP block is not lit, press it to light it.
When using the **BKDF-902**: Skip to step **2**.
- 2** Press the SYSTEM button.
A settings sub menu of the System sub menu appears in the display panel.
- 3** Press the \triangleleft or \triangleright button in the numeric keypad until the Other sub menu appears.
“Other” appears in the sub menu title display area. If it is already displayed there, you can skip this step.
- 4** Rotate the F1 knob to select PGM or PVW.

When using the BKDF-901

Knob	Parameter	Description	Settings
F1	Cursor	The screen where the chroma key cursor appears	PGM : Program screen PVW : Preview screen

When using the BKDF-902

Knob	Parameter	Description	Settings
F1	Cursor	The screen where the chroma key cursor appears.	M/E PGM : Program screen M/E PVW : Preview screen

Inserting Keys by a Cut Transition

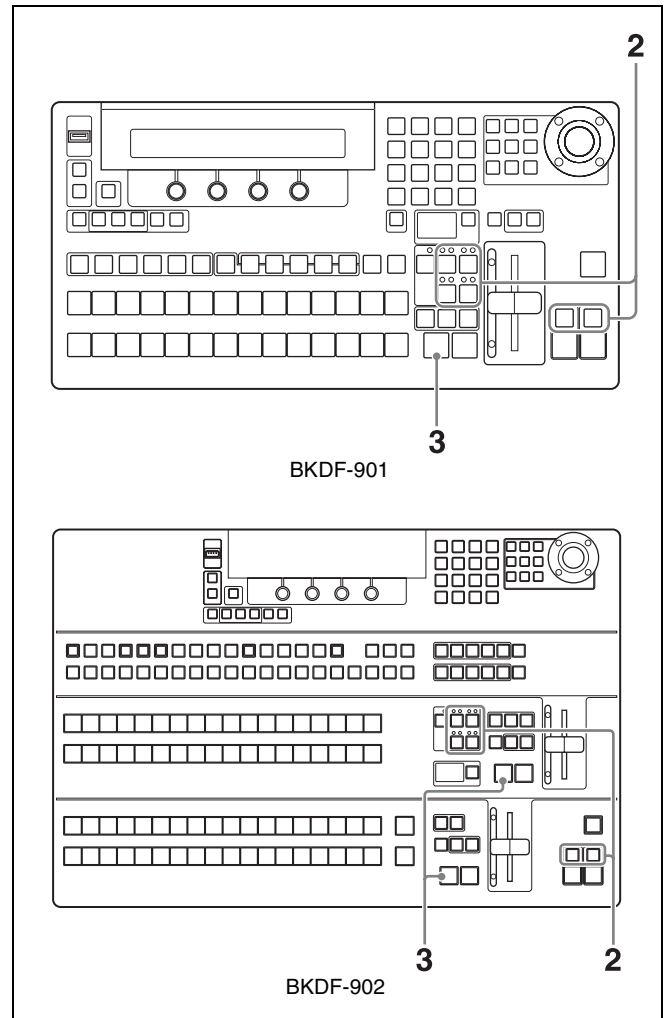

- 1** Set up the key signal.

For information about how to set up keys, see “Setting Up Keys” (page 122).

- 2 Press the next transition selection button that selects the key you have set up (KEY1 to KEY4, multiple selections possible), lighting the button.
- 3 Press the CUT button.

The key video is inserted instantly into the background video.

When the key is inserted, the key on indicator (red) above the button lights.

When you press the CUT button once more, the indicator goes out and the video returns to the original background video.

Inserting Keys by a Mix Transition

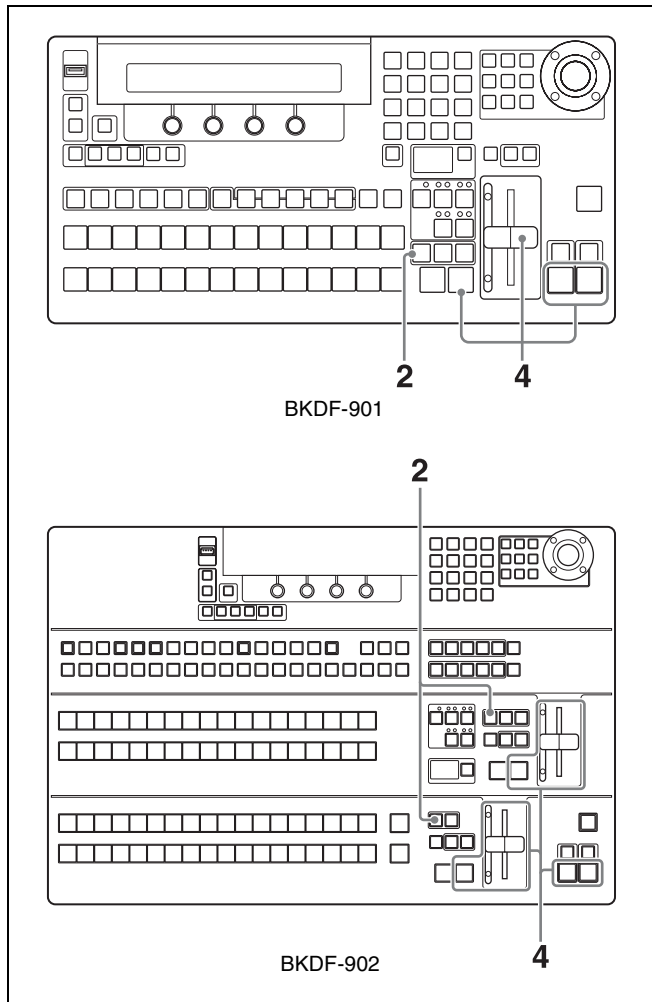

- 1 Carry out steps 1 and 2 of the previous section, "Inserting Keys by a Cut Transition".
- 2 Press the MIX button, lighting it.
- 3 Set the transition rate as required.

For information about how to set transition rates, see "Setting Transition Rates" (page 117).

- 4 Use an AUTO TRANS button or the fader lever to execute the mix transition.

For information about how to execute a transition, see "Using Transitions to Switch to the Next Video (Mix and Wipe)" (page 111).

Inserting Keys by a Wipe or DME Wipe Transition

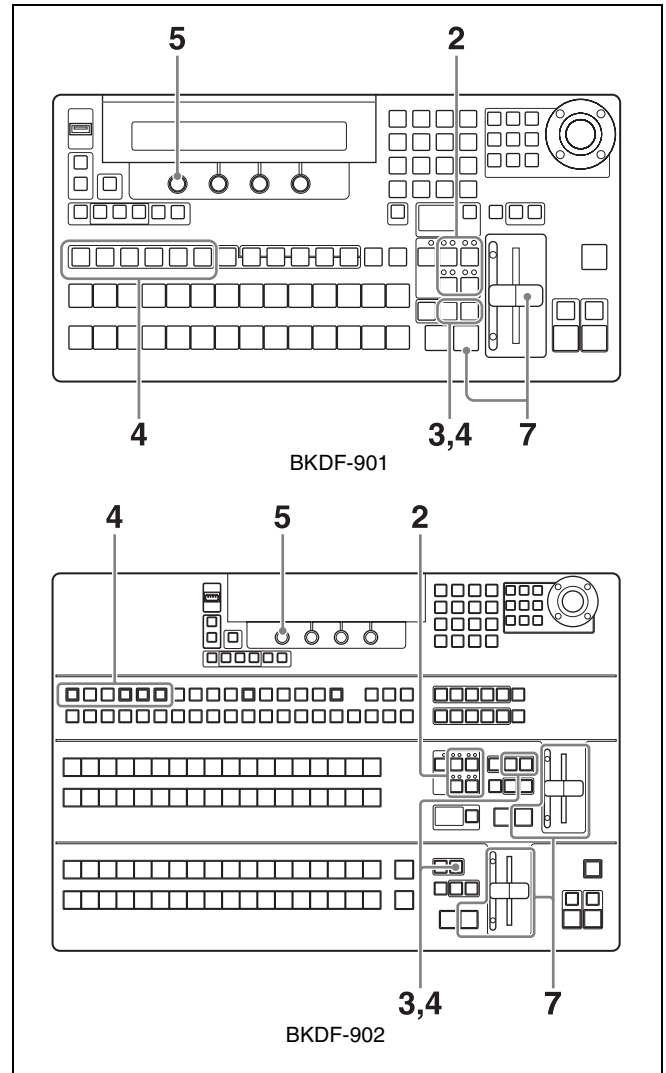

- 1 Set up the key signal.
For information about how to set up keys, see "Setting Up Keys" (page 122).
- 2 Press the next transition selection button that selects the key you have set up (KEY1 to KEY4, multiple selections possible), lighting the button.
- 3 **When using the BKDF-901:** In the transition block, press the WIPE button or the DME button, lighting the button.

When using the BKDF-902: In the M/E transition block, press the WIPE button or the DME button, lighting it. Or in the PROGRAM/PRESET transition block, press the WIPE button, lighting it.

If you pressed the WIPE button in the transition block, the WIPE menu appears.

If you pressed the WIPE button of the M/E transition block, the M/E WIPE menu appears.

If you pressed the WIPE button of the PROGRAM/PRESET transition block, the P/P WIPE menu appears.

Notes

- DME must be enabled to use DME wipe patterns. Pressing the DME button when DME is not enabled has no effect. To enable and disable DME, press the DME ENABLE button in the KEYSER block. When DME is enabled, the DME indicator above the button for the selected key lights in green.
- You can use multiple keys simultaneously in a transition, but when you specify a normal wipe pattern, all of the keys use the same pattern. However, when you specify DME wipe patterns, you can repeat steps **4** and **5** to use different patterns for each key.

- 4** If you pressed the DME button in step **3**, adjust DME wipe patterns for each key. Select the desired key and then press the DME button again.

The DME menu for the operation target key selected in the KEY appears.

- 5** Rotate the F1 knob to select a wipe pattern or a DME wipe pattern.

To select by entering a pattern number, press the F1 knob, enter the number in the numeric keypad, and then press the ENTER button.

For pattern numbers, see “Wipe” (page 189) and “DME Wipe” (page 192).

- 6** Set the transition rate and transition direction as required.

For information about how to set transition rates and transition directions, see “Setting Transition Rates” (page 117) and “Reversing the directions of transitions” (page 112).

Tip

You can adjust wipe and DME wipe patterns.

For details, see “Adjusting Wipes and Keys” (page 132).

- 7** Execute the transition with an AUTO TRANS button or the fader lever.

Changing Key Priorities

You can specify the priorities of keys 1 to 4. The priorities determine the rank of keys with respect to the background.

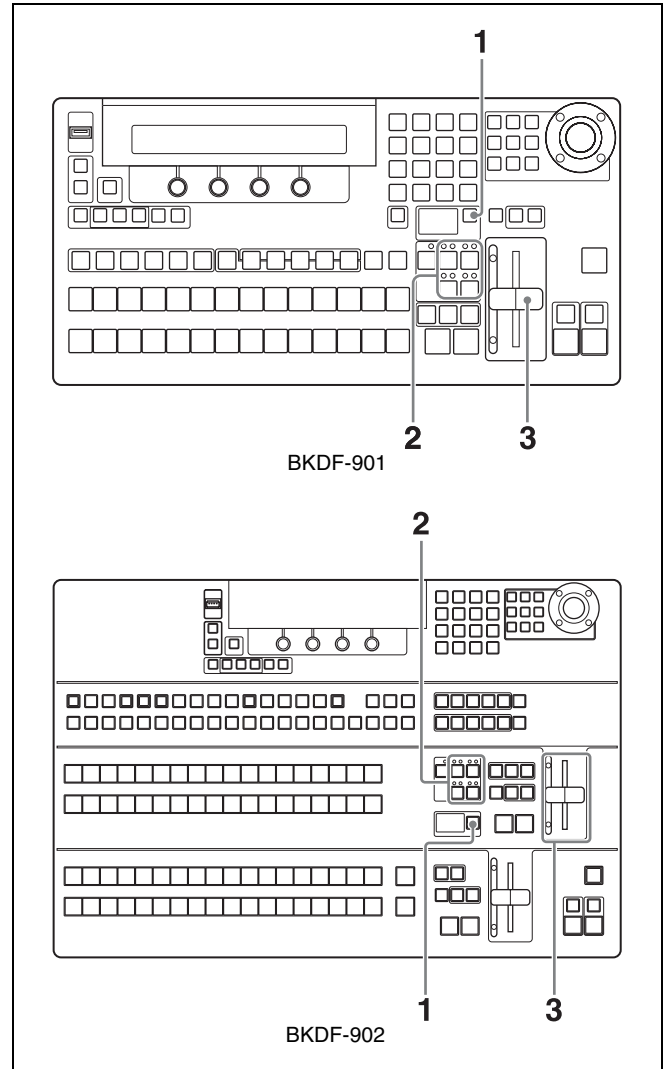

- 1** Press the PRIORITY button, lighting it.

The next transition selection buttons KEY1 to KEY4 light in orange, and the key priority matrix displays the current key priorities.

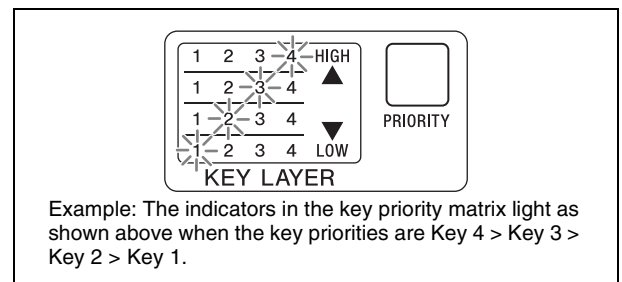

- 2 Press each of the next transition selection buttons KEY1 to KEY4, beginning with the key that you want to have the highest priority.

The key priority matrix changes to reflect the order in which you pressed the buttons.

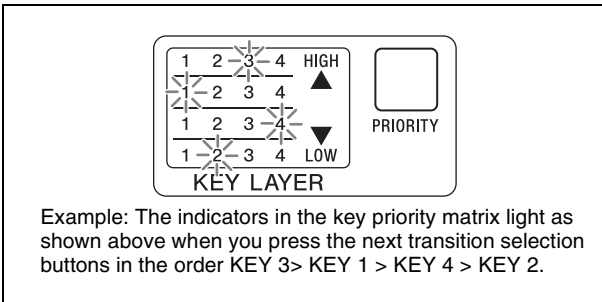

If you do not press all four buttons, the priority setting operation is cancelled the next time that you press the PRIORITY button.

- 3 Move the fader lever all the way to the top or bottom. The new key priority settings are saved.

Applying DME Effects to Keys

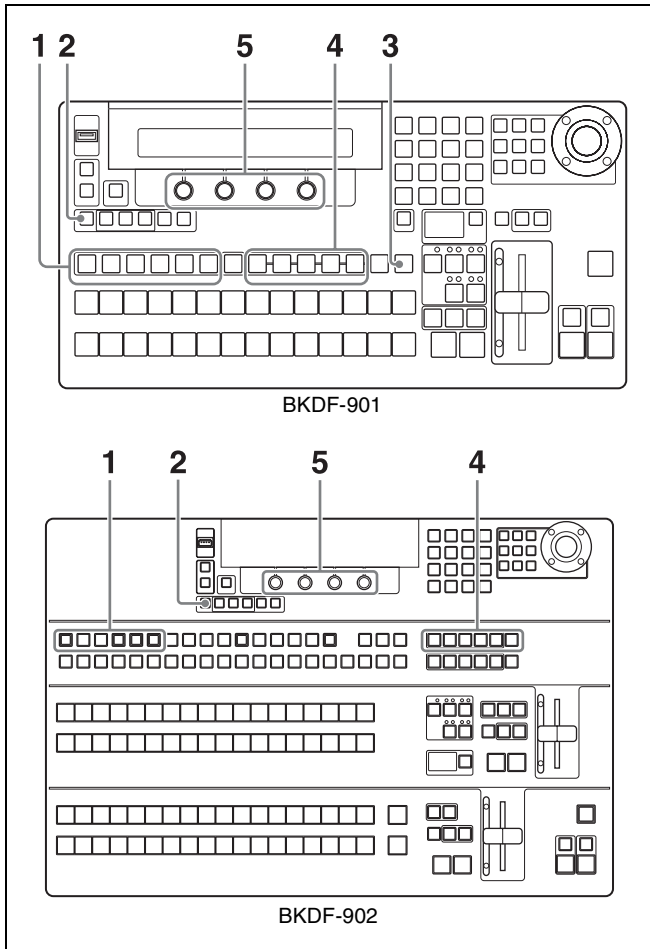

- 1 In the KEY DELEGATION block (when using the BKDF-901) or in the key/AUX bus control block (when using the BKDF-902), select the target key of the operation.

- 2 Press the DME ENABLE button in the KEYER block, lighting it.

For more information about the function of this button, see page 14.

- 3 **When using the BKDF-901:** Press the SHIFT button in the DME/SETUP block, lighting it.

When using the BKDF-902: Skip to step 4.

- 4 Press a DME setting button such as BASIC or BORDER.

- 5 Rotate the F1 to F4 knobs to adjust the parameters.

For details, see “Customizing DME Effects” (page 134).

Inserting Downstream Keys (with a Cut)

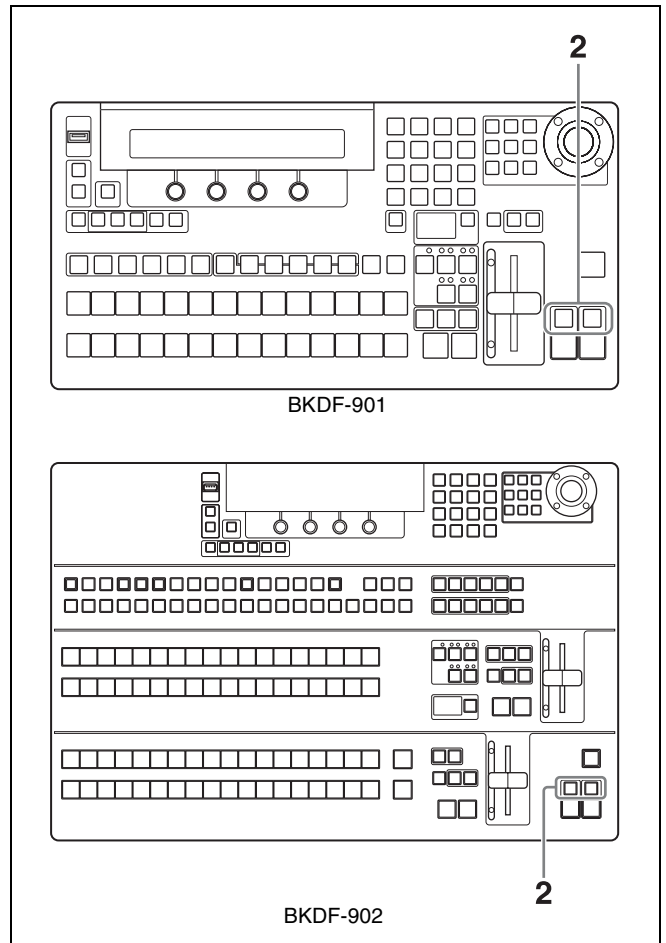

- 1 Set up the key signal.

For information about how to set up keys, see “Setting Up Keys” (page 122).

- 2 In the transition block (when using the BKDF-901) or in the DSK/fade to black control block (when using the BKDF-902), press the DSK1 ON or DSK2 ON button.

The pressed button lights, and a downstream key is inserted.

Press the button again to delete the downstream key and turn the button off.

- 3 Press the DSK1 or DSK2 AUTO TRANS button.

The transition is executed at the specified transition rate.

Note

Some functions cannot be used with downstream keys. Functions that are not available include chroma key, wipe patterns, DME wipe patterns, key masks (but box mask is available), and edges.

Inserting Downstream Keys (with a Mix)

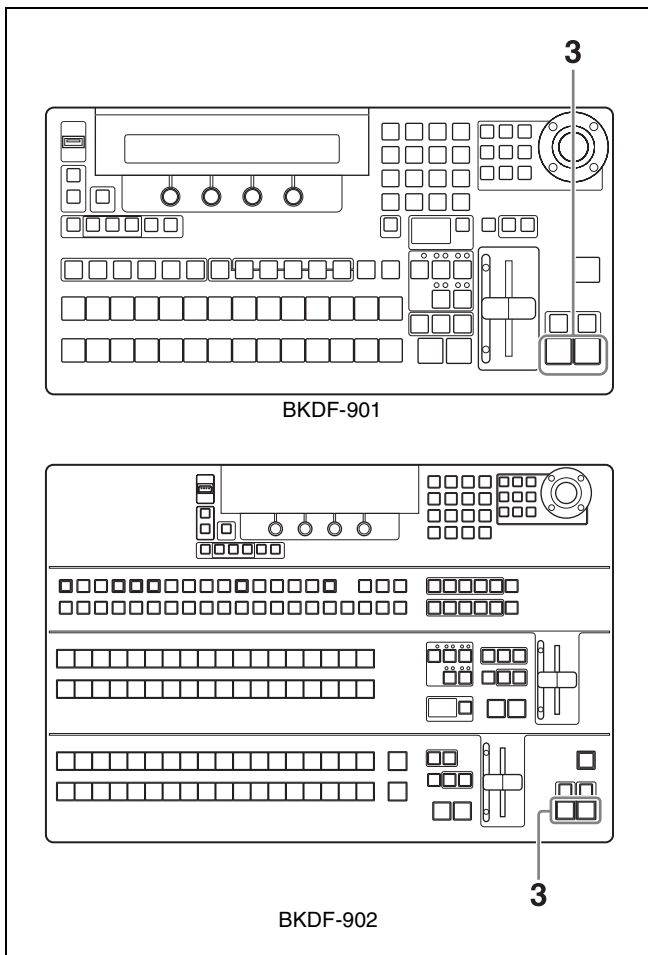

- 1 Set up the key signal.

For information about how to set up keys, see “Setting Up Keys” (page 122).

- 2 Set the transition rate for downstream keys.

For information about how to set transition rates, see “Setting Transition Rates” (page 117).

Using Fade to Black

You can use the switcher's internally generated black signals in transitions. A transition in which the background is replaced by a black signal is called "fade to black".

Tip

Fade to black has the highest priority among all transitions. You can press the FTB button during execution of any other type of transition to fade to a black screen.

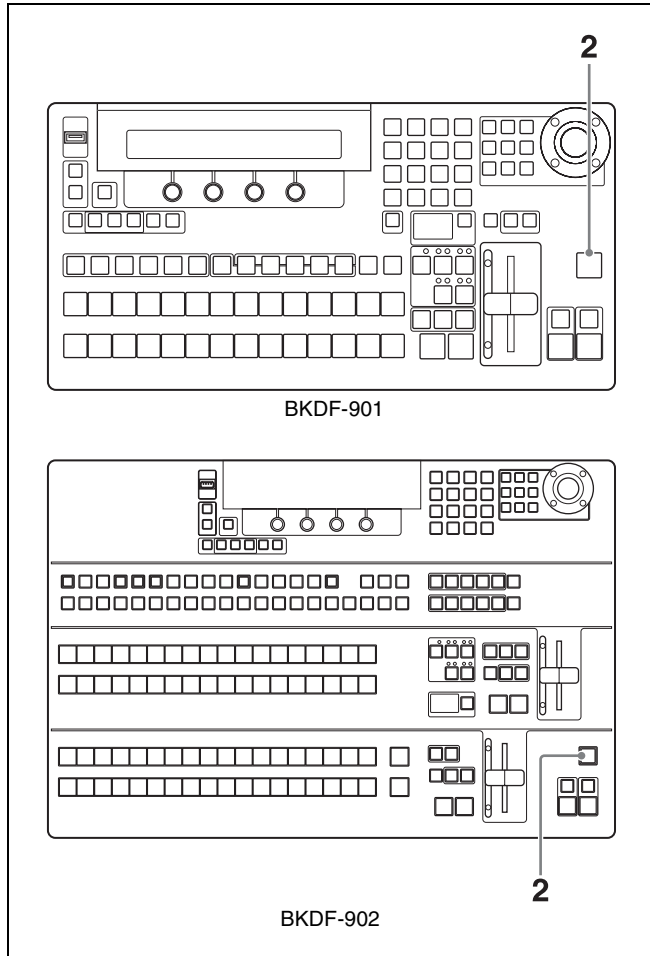

- 1 Set the transition rate for fade to black.

For information about how to set transition rates, see "Setting Transition Rates" (page 117).

- 2 Press the FTB button in the transition block (when using the BKDF-901) or in the DSK/fade to black control block (when using the BKDF-902).

The video being output to program output fades out according to the specified transition rate, and is replaced by a black screen.

If you press the FTB button once more after the fade to black finishes, the switcher executes a transition back to the original video.

If you press the FTB button during a fade to black, the original video is restored instantly.

You can add detailed effects to the wipe patterns used in transitions and to the keys which are inserted into background video.

When the sub menu and parameter names that appear in the display panel are different from the sub menu and parameter names that appear in GUI menu screens, this chapter shows both, with the names that appear in GUI menu screens enclosed in parentheses.

For more information about the names that appear in GUI menu screens, see “Menu Operations in the GUI Menus” (page 64).

Customizing Wipe Patterns

When you operate with transitions and keys, you can customize the selected wipe pattern. For example, you can add borders to a pattern, or modify the pattern’s shape or position. Customized patterns can be registered as user patterns.



Border example

For information about how to select wipe patterns, see “Switching with Wipe and DME Wipe Transitions” (page 115) or “Inserting Keys by a Wipe or DME Wipe Transition” (page 127).

Adding Borders to Wipe Patterns

You can add borders by adjusting the parameters of the Wipe Pattern (Pattern) sub menu and the Wipe Border Color (Border Color) sub menu.

To display the Wipe Pattern (Pattern) and Wipe Border Color (Border Color) sub menus

When using the BKDF-901: Press the WIPE button in the transition block.

When using the BKDF-902: Press the WIPE button in the M/E transition block or in the PROGRAM/PRESET transition block.

The most recently used sub menu appears in the display panel.

To switch between sub menus, use the ◀ and ▶ buttons in the numeric keypad.

Wipe Pattern (Pattern) sub menu parameters

Adjust the following parameters to create a border.

Operation	Knob	Parameter	Settings
Set the border width	F2	Wid (Border Width)	0.0 to 100.0 (Set to 0.0 if you do not want to add a border.)
Set the border softness	F3	Soft (Border Softness)	0.0 to 100.0
Select video to use in the border	F4 ^{a)}	Src (Border Source)	BLK: Black signal IN01 to In24: Input signals 1 to 24 MAT1 to MAT4: Color matte signals 1 to 4 STL1 to STL4: Still images 1 to 4 W.Bd (Wipe Border Matte): Wipe border matte

a) If you have used the F4 knob to change the display names of input signals and internal signals (see page 74), the new display names appear.

Wipe Border Color (Border Color) sub menu parameters

Adjust the following parameters to adjust the border color.

Operation	Knob	Parameter	Settings
Adjust the border luminance	F2	Lum (Luminance)	0.0 to 108.6
Adjust the saturation (color density) of the border color	F3	Sat (Saturation)	0.0 to 100.0
Adjust the hue of the border color	F4	Hue	0.0 to 359.5

Modifying Wipe Patterns

You can modify wipe patterns by adjusting the parameters of the Wipe Modify (Modify) sub menu.

To display the Wipe Modify (Modify) sub menu

Press the WIPE POS button in the joystick block. If another sub menu is displayed, you can switch to the Wipe Modify sub menu by pressing the ◀ and ▶ buttons in the numeric keypad.

Wipe Modify (Modify) sub menu parameters

Adjust the following parameters to change the pattern shape and position.

Operation	Knob Joystick	Parameter	Settings
Set the pattern aspect ratio	F1	Asp (Aspect)	-1.000 to 1.000
Set the pattern horizontal position (X coordinate)	F2 Move left and right	PX (Center Position X)	-1.000 to 1.000
Set the pattern vertical position (Y coordinate)	F3 Move up and down	PY (Center Position Y)	-1.000 to 1.000
Set the pattern rotation angle	F4 Rotate clockwise/ counterclockwise	Ang (Angle)	-16.000 to 16.000

Registering User Patterns

You can use the User sub menu to register customized wipe patterns.

- 1 Customize a wipe pattern with one of the sub menus.
- 2 Press the ◀ or ▶ button in the numeric keypad until the User sub menu appears.
- 3 Rotate the F1 knob in the Display Panel/Menu Control Block to select the number under which to register the pattern.

Knob	Parameter	Description	Settings
F1	Usr (User Pattern)	Number under which to register the pattern	120 to 159 ^{a)}

a) An asterisk (*) appears after the number when a user pattern has already been registered.

- 4 Press the F2 knob and hold it down for one second or longer.

The pattern is registered under the number selected in step 3.

To unregister a pattern

Rotate the F1 knob in the Display Panel/Menu Control Block to select the pattern number to unregister, and then press the F4 knob and hold it down for one second or longer.

Customizing DME Effects

You can use the DME menu to customize the DME effects (digital multi effects) used in transition and key operations. DME effects allow you to change the position, size, and shape of images in three-dimensional space.

This switcher provides six DME channels. Each channel can be used independently, and channels can also be combined to create more complex and sophisticated effects. The number of DME channels currently in use appears at the upper right of the display panel (Now Using DMEs=number of channels).

Adjustment	Sub menu used (menu names as shown in GUI menu screens only)
<ul style="list-style-type: none"> Change position, shape, and size. Set up DME channel. 	DME Basic
Add borders.	Border
Change color type (Chroma Control).	Sub Effects
Adjust 3D DME warp effects.	Warp
Add lighting effects.	Light
Register user patterns.	User

For information about how to select DME wipe patterns, see “Switching with Wipe and DME Wipe Transitions” (page 115) or “Inserting Keys by a Wipe or DME Wipe Transition” (page 127).

For information about how to apply DME effects to keys, see “Applying DME Effects to Keys” (page 129).

Note

Customizations to DME effects are lost when the settings of the switcher are reset and when the switcher is powered off. If you want to reuse customized DME effects, register them as events.

For details, see “Registering Events” (page 151).

To restore the default values for all settings in a sub menu of the DME menu (reset)

When using the BKDF-901: Display the sub menu that you want to reset, hold down the SHIFT button in the DME/SETUP block, and then press the DEFAULT button in the joystick block.

When using the BKDF-902: Display the sub menu that you want to reset, hold down the KEY SRC button in the key/AUX control block, and then press the DEFAULT button in the joystick block.

Changing the Position, Shape, and Size of Images

Use the sub menus of the DME Basic sub menu to do the following.

Sub menu	Operation
Position ^{a)}	Set the position of the image
Rotation ^{a)}	Set the rotation angle of the image
xxx Aspect ^{b)} (Aspect)	Set the aspect ratio of the image
Crop	Crop part of the image
xxx Setup (Setup) ^{b)}	<ul style="list-style-type: none"> Enable or disable DME Select whether to use global coordinates

a) Shown only in GUI menu screens

b) xxx: “M/E DME” appears if you are setting up a transition, and “Keyer” appears if you are setting up a key.

To display the DME Basic sub menus

When using the BKDF-901: Press the SHIFT button of the DME/SETUP block, turning it off, and then press the BASIC button.

When using the BKDF-902: Press the BASIC button in the DME/SETUP block.

The most recently used sub menu appears in the display panel.

To switch between sub menus, press the ◀ and ▶ buttons in the numeric keypad.

You can also display the Position sub menu and the Rotation sub menu directly by pressing the DME POS and DME ROT buttons in the joystick block.

Position sub menu and Rotation sub menu parameters

You can define the positions and angles of images in either of two coordinate systems.

Source coordinates: These are coordinates that refer to the image. The point of origin is the center of the image. The X axis extends horizontally along the image, the Y axis extends vertically along the image, and the Z axis extends into depth.

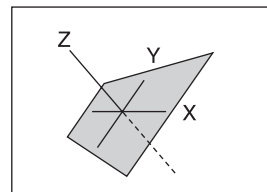

Target coordinates: These are coordinates that refer to the monitor screen. The point of origin is the center of the screen. The X axis extends horizontally, the Y axis extends vertically, and the Z axis extends into depth.

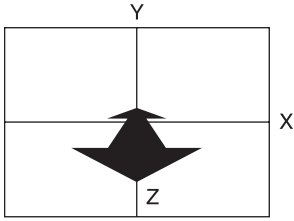

When you are using multiple DME channels, you can also define positions and angles in either local or global coordinates.

Local coordinates: These are coordinates that are local to each DME channel.

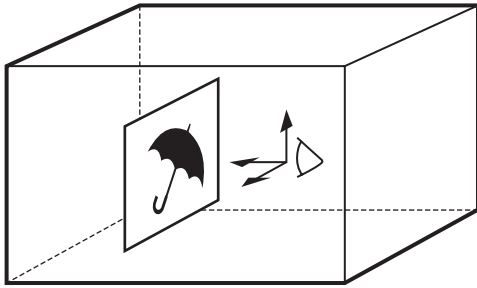

Global coordinates: These are coordinates that are common to all DME channels.

If you want to use global coordinates, you must enable them in the Setup sub menu by setting the Gbl parameter to On (see page 137).

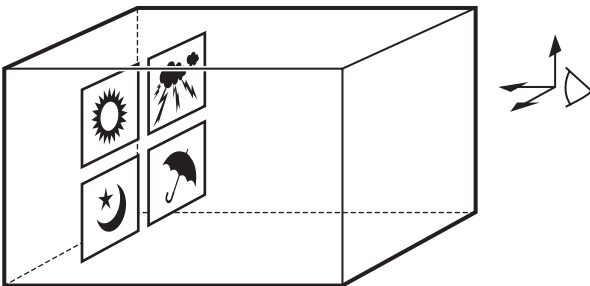

The positions and rotation angles of images differ depending on the coordinates in which they are defined. To adjust parameters in the Position and Rotation sub menus, select the coordinates by selecting the following sub menus.

(xxx: “M/E DME” appears when you are operating on a transition, and “Keyer” appears when you are operating on a key.)

- xxx L.Source (Local Source) sub menu: Change positions and angles in source coordinates.
- xxx L.Target (Local Target) sub menu: Change positions and angles in target coordinates.

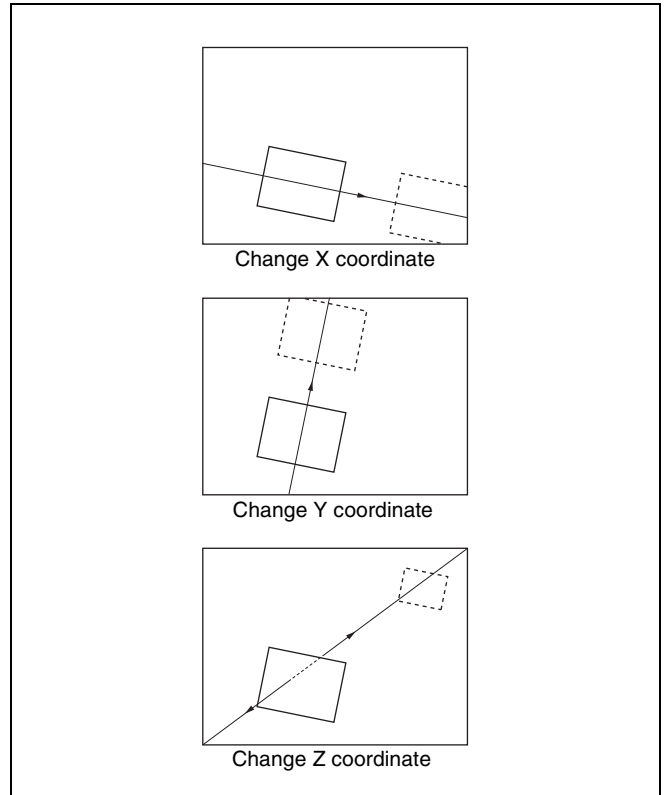

Changing the position of an image in source coordinates

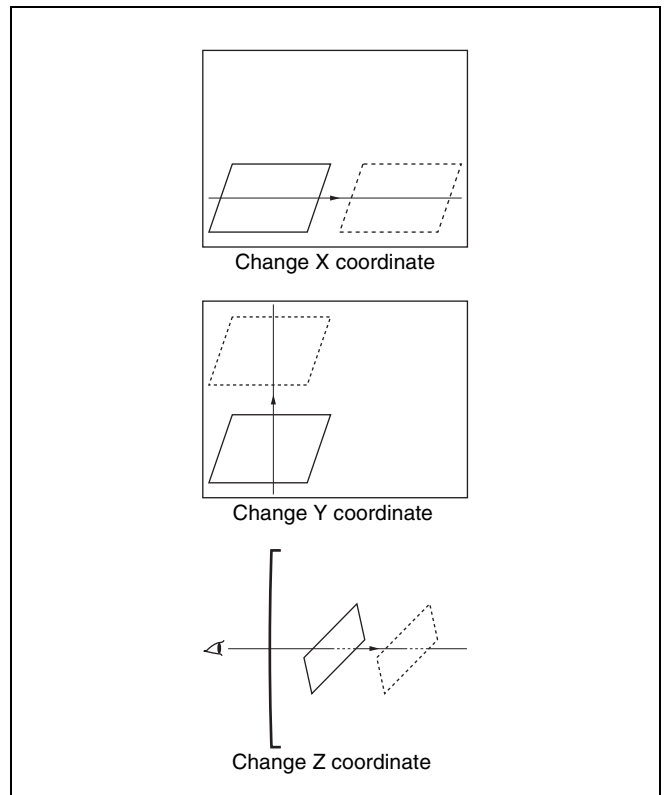

Changing the position of an image in target coordinates

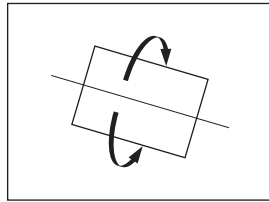

Rotate around X axis

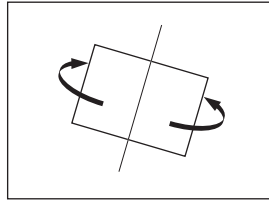

Rotate around Y axis

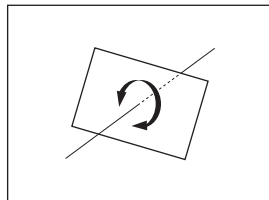

Rotate around Z axis

Changing the rotation angle of an image in source coordinates

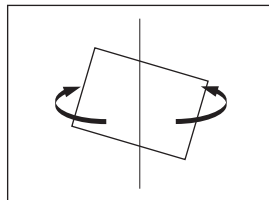

Rotate around X axis

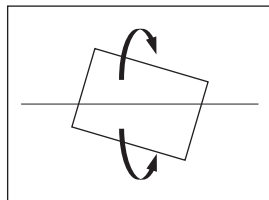

Rotate around Y axis

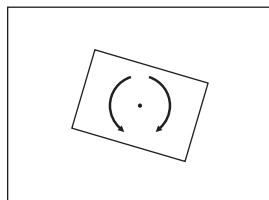

Rotate around Z axis

Changing the rotation angle of an image in target coordinates

Position sub menu parameters

Operations are common for the sub menus of all coordinate systems.

Operation	Knob Joystick	Parameter	Settings
Set the X coordinate (horizontal position) of the image.	F2 Move left and right	PX (Position X)	-8.000 to 8.000
Set the Y coordinate (vertical position) of the image.	F3 Move up and down	PY (Position Y)	-8.000 to 8.000
Set the Z coordinate (depth position) of the image.	F4 Rotate clockwise/ counterclockwise	PZ (Position Z)	-8.000 to 8.000

Rotation sub menu parameters

Operations are common for the sub menus of all coordinate systems.

Operation	Knob Joystick	Parameter	Settings
Set the rotation angle of the image along the X axis (horizontal rotation).	F2 Move left and right	RX (Rotation X)	-8.000 to 8.000
Set the rotation angle of the image along the Y axis (vertical rotation).	F3 Move up and down	RY (Rotation Y)	-8.000 to 8.000
Set the rotation angle of the image along the Z axis (depth rotation).	F4 Rotate clockwise/ counterclockwise	RZ (Rotation Z)	-8.000 to 8.000

Aspect sub menu parameters

Adjust the following parameters to change the aspect ratio of the image.

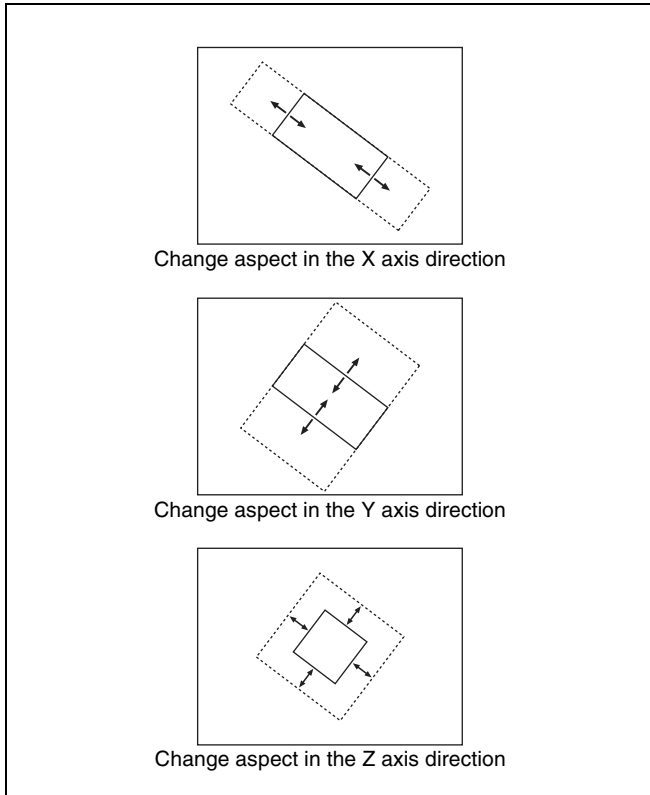

Change aspect in the X axis direction

Change aspect in the Y axis direction

Change aspect in the Z axis direction

Change aspects

Operation	Knob	Parameter	Settings
Specify an aspect in the X axis direction.	F2	X (Aspect X)	0.000 to 8.000
Specify an aspect in the Y axis direction.	F3	Y (Aspect Y)	0.000 to 8.000
Specify an aspect in the Z axis direction.	F4	Z (Aspect Z)	0.000 to 8.000

Crop sub menu parameters

You can crop the top, bottom, left, and right edges of images by specified amounts. To do so, adjust the following parameters.

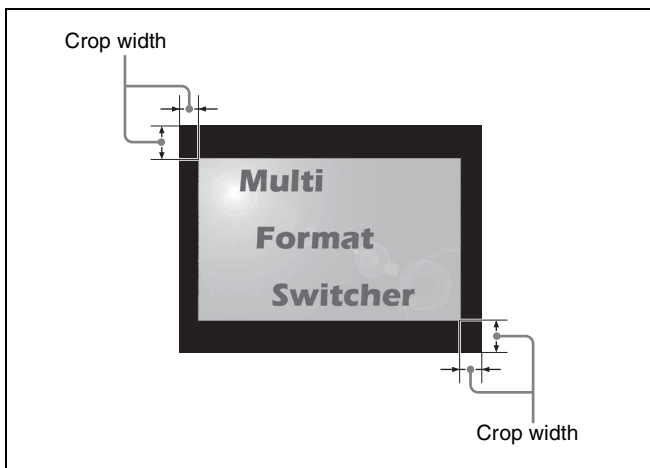

Crop example

Operation	Knob	Parameter	Settings
Specify the crop width for the left side.	F1	L (Left Side)	0.0 to 100.0
Specify the crop width for the right side.	F2	R (Right Side)	0.0 to 100.0
Specify the crop width for the top side.	F3	T (Top Side)	0.0 to 100.0
Specify the crop width for the bottom side.	F4	B (Bottom Side)	0.0 to 100.0

Setup sub menu parameters

Set the following parameters.

Operation	Knob	Parameter	Settings
Enable or disable DME (same function as the DME ENABLE button in the KEYER block (see page 14)).	F1	DME	Off: Disable DME On: Enable DME ^{a)} On-w/K: Disable DME for keys ^{b)} On-w/K: Enable DME for keys ^{b)}
Enable or disable global coordinates.	F2	Gibl (Use Globals)	On: Enable Off: Disable

- a) When you are setting up a transition
- b) When you are setting up a key

Adding Borders to Images

Use the sub menus of the Border sub menu to do the following.

Sub menu	Operation
xxx Border Color ^{a)} (Border Color)	Select whether to add a border to an image, and adjust the color of the border, if added.
M/E DME Inner Width ^{b)} , Keyer Bord Inner Wid ^{c)} (Inner Width)	Adjust the widths of the inner sides of the border.
M/E DME Outer Width ^{b)} , Keyer Bord Outer Wid ^{c)} (Outer Width)	Adjust the widths of the output sides of the border.
M/E DME Border Soft ^{b)} , Keyer Bord Softness ^{c)} (Softness)	Adjust the softness of the inner and outer sides of the border.

Sub menu	Operation
xxx Bevel Color ^{a)} (Bevel Color)	Select whether to add three-dimensional beveled edges to an image, and adjust the color of the beveled edges, if added.
xxx Border HL ^{a)} (Highlight Setup)	Specify the direction and brightness of the light source that illuminates beveled edges.

a) xxx: “M/E DME” appears if you are setting up a transition, and “Keyer” appears if you are setting up a key.

b) Transition sub menu

c) Key sub menu

To display Border sub menus

When using the BKDF-901: Press the SHIFT button in the DME/SETUP block, lighting it, and then press the BORDER button.

When using the BKDF-902: Press the BORDER button in the DME/SETUP block.

The most recently used sub menu appears in the display panel.

To switch between sub menus, press the ◀ and ▶ buttons in the numeric keypad.

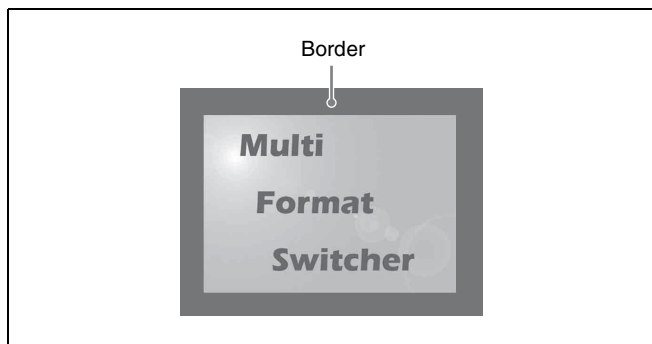

Border example

Border Color sub menu parameters

Adjust the following parameters to select whether to add a border, and to adjust the color of the border, if added.

Operation	Knob	Parameter	Settings
Select whether to add a border to an image.	F1	Bod (Border Enable)	On: Add Off: Do not add
Adjust the luminance of the border.	F2	Lum (Luminance)	0.0 to 108.6
Adjust the saturation (color density) of the border.	F3	Sat (Saturation)	0.0 to 100
Adjust the hue of the border.	F4	Hue	0.0 to 359.5

Inner Width sub menu parameters

Adjust the following parameters to adjust the widths of the inner sides of the border.

Note

When you add beveled edges to an image, it is not possible to adjust the widths of the left, right, top, and bottom edges independently. Set any one of the parameter values.

For information about beveled edge settings, see “Bevel Color sub menu parameters” (page 139).

Operation	Knob	Parameter	Settings
Adjust the width of the left inner side border.	F1	L (Left Side)	0 to 200
Adjust the width of the right inner side border.	F2	R (Right Side)	0 to 200
Adjust the width of the top inner side border.	F3	T (Top Side)	0 to 200
Adjust the width of the bottom inner side border.	F4	B (Bottom Side)	0 to 200

Outer Width sub menu parameters

Adjust the following parameters to adjust the widths of the outer sides of the border.

Note

When you add beveled edges to an image, it is not possible to adjust the widths of the left, right, top, and bottom edges independently. Set any one of the parameter values.

For information about beveled edge settings, see “Bevel Color sub menu parameters” (page 139).

Operation	Knob	Parameter	Settings
Adjust the width of the left outer side border.	F1	L (Left Side)	0 to 100
Adjust the width of the right outer side border.	F2	R (Right Side)	0 to 100
Adjust the width of the top outer side border.	F3	T (Top Side)	0 to 100
Adjust the width of the bottom outer side border.	F4	B (Bottom Side)	0 to 100

Softness sub menu parameters

Adjust the following parameters to adjust the softness of the inner and outer sides of the border.

Operation	Knob	Parameter	Settings
Adjust the softness of the inner side of the border.	F1	InS (Inner Softness)	0 to 15
Adjust the softness of the outer side of the border.	F2	OutS (Outer Softness)	0 to 15

Bevel Color sub menu parameters

Beveled edges make a border appear three dimensional. Adjust the following parameters to select whether to add beveled edges to an image, and to adjust the color of the beveled edges, if added.

Note

It is not possible to adjust the widths of left, right, top, and bottom beveled edges independently.

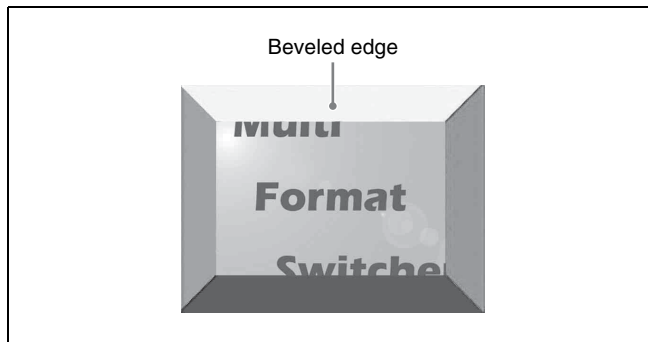

Beveled edge example

For information about how to adjust beveled edge widths, see “Inner Width sub menu parameters” (page 138) and “Outer Width sub menu parameters” (page 138).

Operation	Knob	Parameter	Settings
Select whether to add beveled edges to an image.	F1	BvI (Beveled Enable)	On: Add Off: Do not add
Adjust the luminance of the beveled edges.	F2	Lum (Luminance)	0.0 to 108.6
Adjust the saturation (color density) of the beveled edges.	F3	Sat (Saturation)	0.0 to 100
Adjust the hue of the beveled edges.	F4	Hue	0.0 to 359.5

Border HL (Highlight Setup) sub menu parameters

Adjust the following parameters to specify the direction and brightness of the light source that illuminates beveled edges.

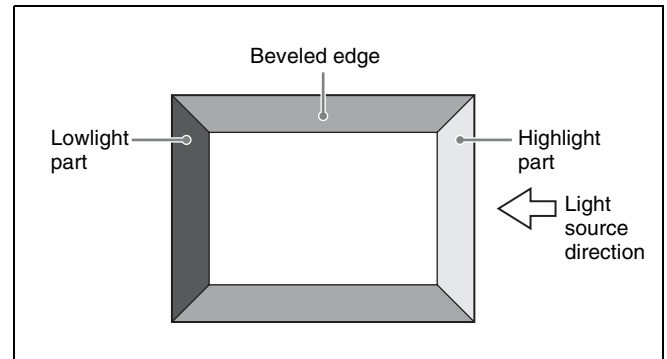

Beveled edge example

Operation	Knob	Parameter	Settings
Set the direction of the light source. (Specify as a position corresponding to a number on the face of an analog clock.) Example: 3 corresponds to the direction from 3 o'clock.	F1	Dir (Hilight Direction)	0 to 11
Set the mixture ratio of the highlight (lighter) part and the border color.	F2	HL (Hilight Opacity)	0 to 100.0
Set the mixture ratio of the lowlight (darker) part and the border color.	F3	LL (Lowligh Opacity)	0 to 100.0

Adding Trail Effects, and Changing the Color Type

You can adjust the parameters of the Sub Effects sub menus to add trail effects to images. You can also change the image color type (chroma control).

Trail effect: Adds trail-like afterimages.

Chroma control: Allows you to change the color type of images to sepia, black and white, or negative.

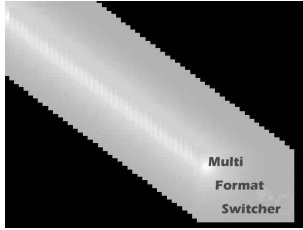

Trail effect example

Make trail and chroma control settings in the following sub menus.

Sub menu	Operation
Trail ^{a)}	Make trail effect settings.
Chroma Control	Change the color type.

a) Shown only on the touch panel

To display the Sub Effects sub menus

Press the SHIFT button in the DME/SETUP block, lighting it, and then press the SUB EFF button. The most recently used sub menu appears in the display panel.

To switch between sub menus, press the ◀ and ▶ buttons in the numeric keypad.

Trail sub menu parameters

Adjust the following parameters to select whether to add a trail effect, and to adjust the length and color of the trail, if added.

The Trail sub menu has two pages. To switch between pages, press the ◀ and ▶ buttons in the numeric keypad.

(xxx: “M/E” appears if you are setting up a transition, and “KEYER” appears if you are setting up a key.)

xxx Trail 1 (1)

Operation	Knob	Parameter	Settings
Selects whether to add a trail effect.	F1	Typ (Trail Type)	Off: Do not add Decay: Add Star: Afterimage disappearing as stardust
Adjusts the length of the afterimages.	F2	Len (Length)	1 to 6

xxx Trail 2 (2)

Operation	Knob	Parameter	Settings
Adjusts the luminance of the afterimages.	F2	Lum (Luminance)	0.0 to 108.6

Operation	Knob	Parameter	Settings
Adjusts the saturation (color density) of the afterimages	F3	Sat (Saturation)	0.0 to 100
Adjusts the hue of the afterimages.	F4	Hue	0.0 to 359.5

Chroma Control sub menu parameters

Adjust the following parameters to change the colors of images (Chroma Control).

Operation	Knob	Parameter	Settings
Select the chroma control type.	F1	T (Type)	Through: Do not change the colors Sepia: Sepia Nega: Negative
Adjust the saturation (color density) of the image color.	F3	Sat ^{a)} (Saturation)	0.0 to 100
Adjust the image hue.	F4	Hue	0.0 to 359.5

a) The video becomes black and white if you select Sepia and set Sat to 0.0.

Adjusting 3D DME Warp Effects

You can adjust the parameters of the Warp sub menus to apply 3D DME warp effects to images. These effects allow you to warp, bend, and divide images in many different ways.

Use the sub menus of the Warp sub menu to do the following.

Sub menu	Operation	Operation target pattern numbers
Ripple ^{a)}	Adjust the parameters of the Ripple effect.	100 to 114
xxx Swirl ^{b)} (Swirl)	Adjust the parameters of the Swirl effect.	115, 116
Mosaic ^{a)}	Adjust the parameters of the Mosaic effect.	117, 118
xxx Slats ^{b)} (Slats)	Adjust the parameters of the Slats effect (which divides the video into separate strips).	119 to 124
Lens ^{a)}	Adjust the parameters of the Lens effect (which shows the video as if seen through a lens).	125 to 184
Page Turn ^{a)}	Adjust the parameters of the Page Turn effect.	185 to 223

Sub menu	Operation	Operation target pattern numbers
Page Peel ^{a)}	Adjust the parameters of the Page Peel effect.	224 to 231
Splits ^{a)}	Adjust the parameters of the Splits effect (which divides the video into separate segments).	232 to 241
Mirror ^{a)}	Adjust the parameters of the Mirror effect.	242 to 249
xxx Defocus ^{c)} (Defocus)	Adjust the parameters of the Defocus effect (which blurs the overall video image).	252

- a) Shown only in GUI menu screens
- b) xxx: "M/E DME" appears if you are setting up a transition, and "Keyer" appears if you are setting up a key.
- c) xxx: "Keyer" appears only if you are setting up a key.

To display the WARP sub menus

When using the BKDF-901: Press the SHIFT button in the DME/SETUP block, turning it off, and then press the WARP button.

When using the BKDF-902: Press the WARP button in the DME/SETUP block.

The most recently used sub menu appears in the display panel.

To switch between sub menus, press the WARP button repeatedly until the sub menu that you want appears.

Ripple sub menu parameters

Adjust the following parameters to adjust the ripple effect.

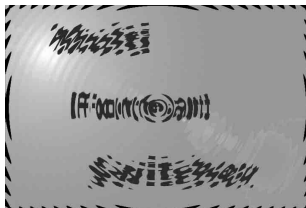

Ripple effect example

The Ripple sub menu has four pages. To switch between pages, press the ◀ and ▶ buttons in the numeric keypad.

(xxx: "M/E DME" appears if you are setting up a transition, and "Keyer" appears if you are setting up a key.)

xxx Ripple 1 (1)

Operation	Knob	Parameter	Settings
Select the ripple type.	F1	Typ (Shape Type)	Hor: Horizontal waves Ver: Vertical waves Rot: Rotating waves Cir: Circular ripple Poly: Polygonal ripple Star: Star shaped ripple
Select the ripple frequency.	F2	Frq (Freq)	-100.0 to 100.0
Select the ripple amplitude.	F3	Amp	-2.000 to 2.000
Select the ripple phase.	F4	Phs (Phase)	-8.000 to 8.000

xxx Ripple 2 (2)

Operation	Knob	Parameter	Settings
Select the wave type.	F1	Wav (Wave Type)	Sine: Sine wave Square: Square wave Triangle: Triangle wave Saw: Saw wave Random: Random wave
Adjust the rotation of the waves.	F2	Rot (Rotation)	-8.000 to 8.000
Select the number of apex points of the star shape (when Star is selected).	F3	Pnt (Points)	2 to 16
Select the sharpness of the star shape (when Star is selected).	F4	Shp (Sharpness)	-100.0 to 100.0

xxx Ripple 3 (3)

Operation	Knob	Parameter	Settings
Specify the number of sides (when Poly is selected).	F1	Sid (Sides)	2 to 32
Specify the X coordinate of the center point of the waves.	F2	PX (Position X)	-8.000 to 8.000
Specify the Y coordinate of the center point of the waves.	F3	PY (Position Y)	-8.000 to 8.000

xxx Modifier (Modifier)

Operation	Knob	Parameter	Settings
Select whether to modify the ripple.	F1	Mod (Modifier)	On: Modify Off: Do not modify
Multi-wave	F2	Zom (Zoom)	-8.000 to 8.000
Specify the aspect ratio of the multi-wave.	F3	Asp (Aspect)	-8.000 to 8.000

Swirl sub menu parameters

Adjust the following parameters to adjust the swirl effect.



Swirl effect example

Operation	Knob	Parameter	Settings
Specify the X coordinate of the center of the swirl.	F2	PX (Position X)	-8.000 to 8.000
Specify the Y coordinate of the center of the swirl.	F3	PY (Position Y)	-8.000 to 8.000
Specify the amount of swirling.	F4	Amt (Amount)	-1.000 to 1.000

Mosaic sub menu parameters

Adjust the following parameters to adjust the Mosaic effect.

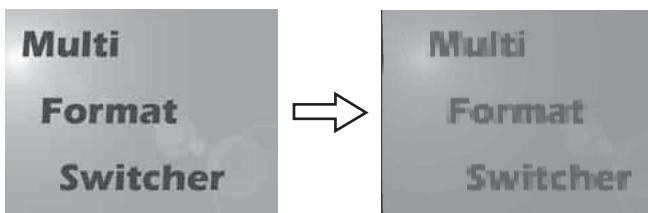

Mosaic effect example

The Mosaic sub menu has two pages. To switch between pages, press the ◀ and ▶ buttons in the numeric keypad.
(xxx: “M/E DME” appears if you are setting up a transition, and “Keyer” appears if you are setting up a key.)

xxx Mosaic 1 (1)

Operation	Knob	Parameter	Settings
Select the type of Mosaic effect.	F1	Typ (Type)	Nor: Normal mosaic Rot: Rotated mosaic
Specify the aspect ratio of one tile.	F2	Asp (Aspect)	-8.000 to 8.000
Specify the size of one tile.	F4	Siz (Size)	0.00 to 32.00

xxx Mosaic 2 (2)

Operation	Knob	Parameter	Settings
Specify the X coordinate of the center of the mosaic.	F2	PX (Position X)	-8.000 to 8.000
Specify the Y coordinate of the center of the mosaic.	F3	PY (Position Y)	-8.000 to 8.000
Adjust the rotation of the mosaic.	F4	ROT (Rotation)	-8.000 to 8.000

Slats sub menu parameters

Adjust the following parameters to adjust the Slats effect.

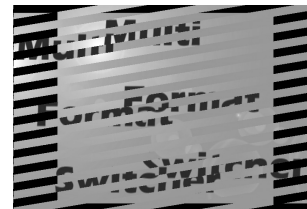

Slats effect example

Operation	Knob	Parameter	Settings
Select the way in which the slats are arranged.	F1	Typ (Shape Type)	Hor: Horizontal Ver: Vertical HV: Horizontal and vertical Rot: Rotated HV-R: Rotated horizontally and vertically
Specify the rotation angle of the slats.	F2	Rot (Rotation)	-8.000 to 8.000
Specify the width of the slats.	F3	Wid (Slat_Width)	0.000 to 1.000
Specify the position of the slats.	F4	Amt (Amount)	-1.000 to 1.000

Lens sub menu parameters

Adjust the following parameters to adjust the Lens effect.



Lens effect example

The Lens sub menu has four pages. To switch between pages, press the ◀ and ▶ buttons in the numeric keypad.

(xxx: “M/E DME” appears if you are setting up a transition, and “Keyer” appears if you are setting up a key.)

xxx Lens 1 (1)

Operation	Knob	Parameter	Settings
Select the lens shape.	F1	Typ (Shape Type)	Cir: Circle Poly: Polygon Star: Star
Specify the rotation angle of the lens.	F2	Rot (Rotation)	–8.000 to 8.000
Specify the number of apex points (when Poly or Star is selected).	F3	Pnt (Points)	1 to 16
Specify the lens focal distance.	F4	Amt (Amount)	–8.000 to 8.000

xxx Lens 2 (2)

Operation	Knob	Parameter	Settings
Select the pattern.	F1	Typ (Type)	Rnd: Round Lin: Linear Mul: Multi
Specify the X coordinate of the lens.	F2	PX (Position X)	–8.000 to 8.000
Specify the Y coordinate of the lens.	F3	PY (Position Y)	–8.000 to 8.000
Specify the size of the lens.	F4	Siz (Size)	0.000 to 1.000

xxx Lens 3 (3)

Operation	Knob	Parameter	Settings
Specify the tilt of the lens.	F4	Tlt (Tilt)	0.000 to 1.000

xxx Modifier (Modifier)

Operation	Knob	Parameter	Settings
Specify whether to modify the lens.	F1	Mod (Modifier)	On: Modify Off: Do not modify
Multi-lens	F2	Zom (Zoom)	–8.000 to 8.000
Specify the aspect ratio of the multi-lens.	F3	Asp (Aspect)	–8.000 to 8.000

Page Turn sub menu parameters

Adjust the following parameters to adjust the Page Turn effect.

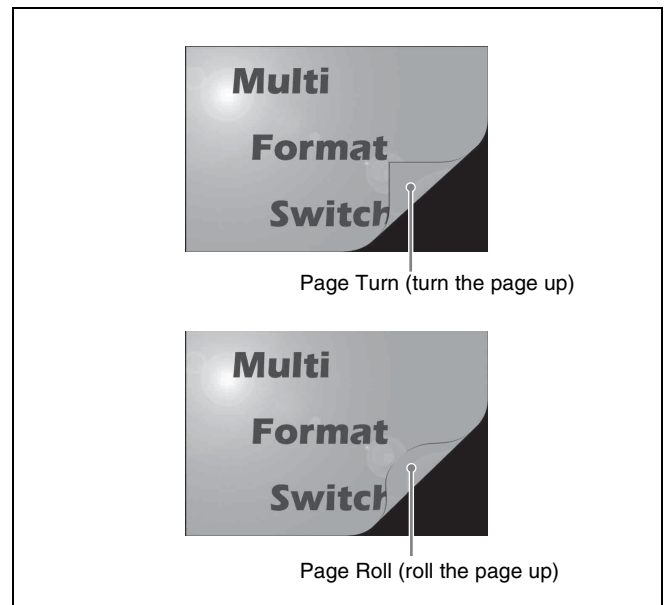

Page Turn effect examples

The Page Turn sub menu has three pages. To switch between pages, press the ◀ and ▶ buttons in the numeric keypad.

(xxx: “M/E DME” appears if you are setting up a transition, and “Keyer” appears if you are setting up a key.)

xxx Page Turn 1 (1)

Operation	Knob	Parameter	Settings
Select the way in which the page is turned.	F1	Pat (Pattern)	Sing: Turn from one direction Quad: Turn from four directions Multi: Turn from multiple directions ZipT: Turn from top ZipR: Turn from right ZipB: Turn from bottom ZipL: Turn from left

Operation	Knob	Parameter	Settings
Specify the rotation angle of the turn.	F2	Rot (Rotation)	-8.000 to 8.000
Specify the angle of the turn.	F3	Ang (Peel Angle)	-8.000 to 8.000
Specify the size of the turn.	F4	Amt (Amount)	-2.000 to 2.000

xxx Page Turn 2 (2)

Operation	Knob	Parameter	Settings
Select Page Roll (roll the page up) or Page Turn (turn the page up).	F1	Typ (Type)	Turn: Page Turn Roll: Page Roll
Specify the X coordinate of the center position of the page turn.	F2	PX (Position X)	-8.000 to 8.000
Specify the Y coordinate of the center position of the page turn.	F3	PY (Position Y)	-8.000 to 8.000
Specify the number of segments in the turn.	F4	Num (Num_Segment)	3 to 31

xxx Page Turn 3 (3)

Operation	Knob	Parameter	Settings
Specify the radius of the turn.	F2	Rad (Radius)	0.000 to 1.000
Specify the amount of spiraling when the turn width is increased stepwise.	F3	Spl (Spiral)	-8.000 to 8.000
Specify staggering of the turn position.	F4	Stg (Stagger)	-8.000 to 8.000

Page Peel sub menu parameters

Adjust the following parameters to adjust the Page Peel effect.

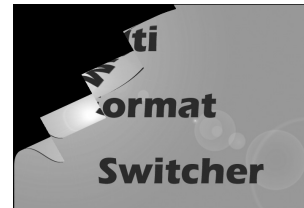

Page Peel effect example

The Page Peel sub menu has two pages. To switch between pages, press the ◀ and ▶ buttons in the numeric keypad.

(xxx: “M/E DME” appears if you are setting up a transition, and “Keyer” appears if you are setting up a key.)

xxx Page Peel 1 (1)

Operation	Knob	Parameter	Settings
Select Page Roll (roll the page up) or Page Turn (turn the page up).	F1	Typ (Type)	Turn: Page Turn Roll: Page Roll
Specify the rotation angle of the peel.	F2	Rot (Rotation)	-8.000 to 8.000
Specify the width of a strip when peeling off in strips.	F3	Wid (Peel_Width)	0.000 to 1.000
Specify the amount of peeling.	F4	Amt (Amount)	-2.000 to 2.000

xxx Page Peel 2 (2)

Operation	Knob	Parameter	Settings
Specify the tilt of the peel.	F3	Tilt (Tilt)	-1.000 to 1.000
Specify the size of the distance out to the peel.	F4	Rad (Radius)	0.000 to 1.000

Splits sub menu parameters

Adjust the following parameters to adjust the Splits effect

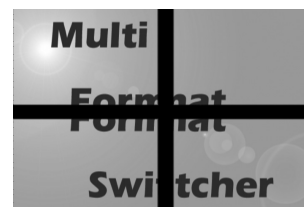

Splits effect example

The Splits sub menu has two pages. To switch between pages, press the ◀ and ▶ buttons in the numeric keypad.

(xxx: “M/E DME” appears if you are setting up a transition, and “Keyer” appears if you are setting up a key.)

xxx Splits 1 (1)

Operation	Knob	Parameter	Settings
Select the type of division.	F1	Typ (Type)	2Way-H: Divided into two parts, left and right 2Way-V: Divided into two parts, top and bottom 4Way: Divided into four parts Multi: Divided into multiple parts
Specify the rotation angle of the divisions (when Multi is selected).	F2	Rot (Rotation)	-8.000 to 8.000
Adjust the distance between the parts when dividing into a spiral.	F3	Spl (Spiral)	-8.000 to 8.000
Adjust the displacement between parts when parts are staggered.	F4	Stg (Stagger)	-8.000 to 8.000

xxx Splits 2 (2)

Operation	Knob	Parameter	Settings
Specify the number of divisions (when Multi is selected).	F1	Num (Num_Segment)	3 to 31
Specify the X coordinate of the center point of the division (when Multi is selected).	F2	PX (Position X)	-8.000 to 8.000
Specify the Y coordinate of the center point of the division (when Multi is selected).	F3	PY (Position Y)	-8.000 to 8.000
Specify the amount of movement of the divided area.	F4	Amt (Amount)	-2.000 to 2.000

Mirror sub menu parameters

Adjust the following parameters to adjust the Mirror effect.



Mirror effect example

The Mirror sub menu has two pages. To switch between pages, press the ◀ and ▶ buttons in the numeric keypad.

(xxx: “M/E DME” appears if you are setting up a transition, and “Keyer” appears if you are setting up a key.)

xxx Mirror 1 (1)

Operation	Knob	Parameter	Settings
Specify the type of division.	F1	Typ (Type)	2Way0 (2 way, 0) 2Way1 (2 way, 1) 2Way2 (2 way, 2) 2Way3 (2 way, 3) 4Way0 (4 way, 0) 4Way1 (4 way, 1) 4Way2 (4 way, 2) 4Way3 (4 way, 3) Multi (multiple divisions)
Specify the rotation angle of the mirror (when Multi is selected).	F2	Rot (Rotation)	-8.000 to 8.000

xxx Mirror 2 (2)

Operation	Knob	Parameter	Settings
Specify the number of mirrors (when Multi is selected).	F1	Num (Num_Segment)	1 to 31
Specify the X coordinate of the center point of the mirror.	F2	PX (Position X)	-8.000 to 8.000
Specify the Y coordinate of the center point of the mirror.	F3	PY (Position Y)	-8.000 to 8.000

Defocus sub menu parameters

Adjust the following parameter to specify the level (amount of blurring) of the Defocus effect.



Defocus effect example

Operation	Knob	Parameter	Settings
Adjust the amount of blurring.	F4	Amt (Amount)	0 to 100

Adding Lighting Effects

You can adjust the parameters of the Light sub menu to add lighting effects to images.



Example of a lighting effect applied to a ripple effect

Use the sub menus of the Light sub menu to do the following.

Sub menu	Operation
xxx DME L.Type ^{a)} (Type)	Select the type of light source.
Light 1 and 2 ^{b)}	Specify the size of the light source, its position, and the color of highlighted parts.

a) xxx: “M/E DME” appears if you are setting up a transition, and “Keyer” appears if you are setting up a key.

b) Shown only in GUI menu screens

To display the Light sub menus

When using the BKDF-901: Press the SHIFT button in the DME/SETUP block, lighting it, and then press the LIGHT button.

When using the BKDF-902: Press the LIGHT button in the DME/SETUP block.

The most recently used sub menu appears in the display panel.

To switch between sub menus, press the ◀ and ▶ buttons in the numeric keypad.

To select the type of light source in the Type sub menu

Operation	Knob	Parameter	Settings
Select the type of light source. (Select Off if you do not want to add a lighting effect to the image.)	F1	Typ (Type)	Off: No light source 1-HL: Highlight 1 2-HL: Highlight 1 HL/LL: Highlight and low-light

Light 1 and Light 2 sub menu parameters

When you have selected 1-HL or 2-HL in the Type sub menu, use the Light 1 and Light 2 sub menus to adjust the size and position of the light source and to adjust the color of highlighted parts.

The Light 1 and Light 2 sub menus each have two pages. To switch between pages, press the ◀ and ▶ buttons in the numeric keypad.

(xxx: “M/E DME” appears if you are setting up a transition, and “Keyer” appears if you are setting up a key.)

xxx L1/xxx L2 Position (Position)

Operation	Knob	Parameter	Settings
Specify the size of the light source (plane light source)	F1	Siz (Size)	0.0 to 100.0
Specify the X coordinate of the center point of the light source.	F2	PX (Position X)	-1.000 to 1.000
Specify the Y coordinate of the center point of the light source.	F3	PY (Position Y)	-1.000 to 1.000
Specify the Z coordinate of the center point of the light source.	F4	PZ (Position Z)	-1.000 to 1.000

Lxxx L1/xxx L2 Color (Color)

Operation	Knob	Parameter	Settings
Specify the mixing ratio between the color of the highlighted parts and the base color.	F1	Opac (Opacity)	0 to 100.0

Operation	Knob	Parameter	Settings
Adjust the luminance of the highlighted parts.	F2	Lum (Luminance)	0.0 to 108.6
Adjust the saturation of the highlighted parts.	F3	Sat (Saturation)	0 to 100.0
Adjust the hue of the highlighted parts.	F4	Hue	0.0 to 359.5

Registering User Patterns

You can use the User sub menu to register DME wipe patterns that you have customized.

- 1 Customize a DME wipe pattern using one of the sub menus.
- 2 **When using the BKDF-901:** Press the SHIFT button in the DME/SETUP block, turning it off, and then press the USER button.

When using the BKDF-902: Press the USER button in the DME/SETUP block.

The User sub menu appears in the display panel.

- 3 Rotate the F1 knob in the Display Panel/Menu Control Block to select the number under which to register the pattern.

Knob	Parameter	Description	Settings
F1	Usr (User Pattern)	Number under which to register the user pattern	300 to 339 ^{a)}

a) An asterisk (*) appears after the number when a user pattern has already been registered.

- 4 Press the F2 knob and hold it down for one second or longer.

The pattern is registered under the number selected in step 3.

To unregister a pattern

Rotate the F1 knob in the Display Panel/Menu Control Block to select the pattern number to unregister, and then press the F4 knob and hold it down for one second or longer.

Applying Masks to Keys

You can use mask patterns to hide defects or unneeded parts of keys.

Use the Key Mask sub menu of the Keyer menu to select mask patterns and to specify the location and size of the pattern.

Note

Box masks are the only masks that can be applied to downstream keys (see page 150). Other mask patterns cannot be selected for downstream keys.

To enable key masks

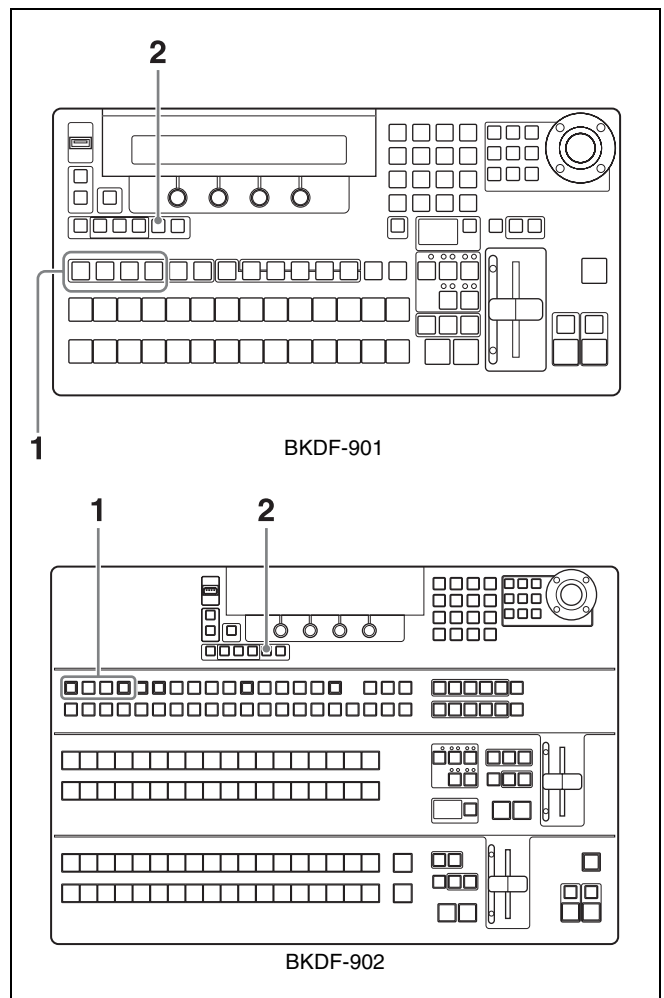

- 1 **When using the BKDF-901:** Depending on the key that you want to mask, press one of the KEY1 to KEY4 buttons in the KEY DELEGATION block, lighting it.

When using the BKDF-902: Depending on the key that you want to mask, press one of the KEY1 to

KEY4 buttons in the key/AUX bus control block, lighting it.

- 2 Press the MASK button in the KEYER section, lighting it.

Key masks are enabled, and the Key Mask sub menu appears in the display panel.

To select a mask pattern and change the position or size of the pattern

Adjust the parameters of the Key Mask sub menu.

Operation	Knob	Parameter	Settings
Select a pattern.	F1	Pat (Mask Pattern)	0 to 33, 38 to 40, 42 to 48, 65 to 69, 75 to 79, 85 to 94, 105 to 114
Specify the X coordinate of the center point of the pattern.	F2	PX (Pattern Center X)	-1.000 to 1.000
Specify the Y coordinate of the center point of the pattern.	F3	PY (Pattern Center Y)	-1.000 to 1.000
Adjust the size of the pattern.	F4	Siz (Pattern Size)	0.0 to 100.0

Adding Edges to Keys

You can use the Edge Shadow sub menu of the Keyer menu to add various types of edges to keys.

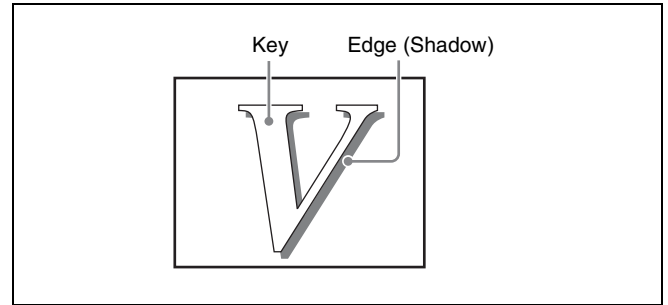

Edge example (Shadow)

Note

Edges cannot be added when you have selected chroma key as the key type, and edges cannot be added to downstream keys.

To enable shadow edges

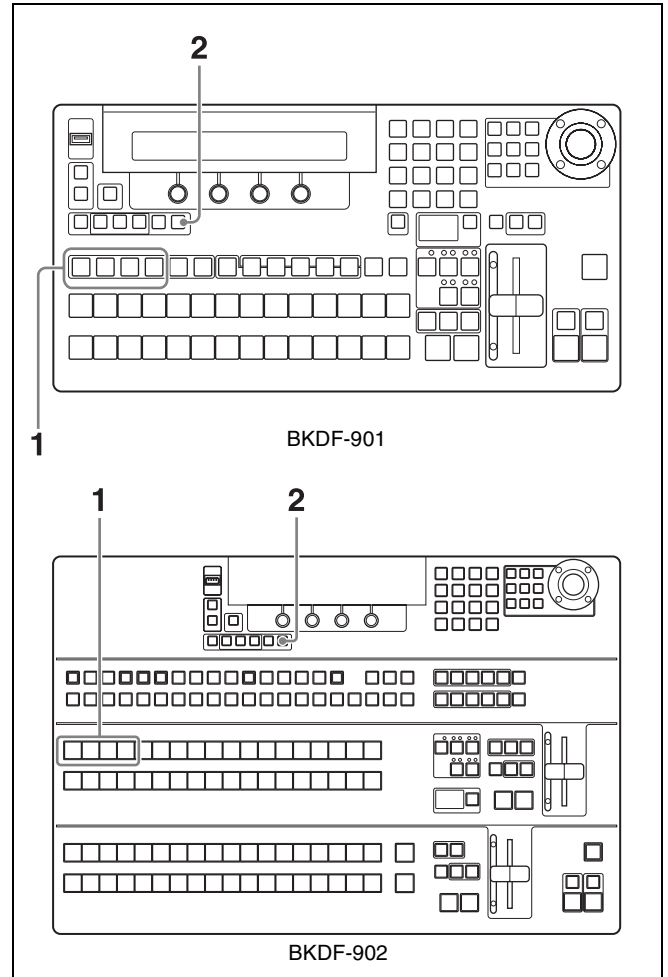

- 1 When using the BKDF-901:** Depending on the key to which you want to add the edges, press one of the KEY1 to KEY4 buttons in the KEY DELEGATION block, lighting it.

When using the BKDF-902: Depending on the key to which you want to add the edges, press one of the KEY1 to KEY4 buttons in the key/AUX bus control block, lighting it.

- 2** Press the EDGE SHADOW button in the KEYSER block, lighting it.

Edges (Shadows) are enabled, and the Edge Shadow sub menu appears in the display panel.

Edge Shadow sub menu parameters

Use the sub menus of the Edge Shadow sub menu to do the following.

Sub menu	Operation
Edge Type (Type)	Select the edge type, and specify properties such as the edge width and softness.
Edge Color (Color)	Adjust the edge color.
Edge Position (Position)	Adjust the edge position.

To switch between sub menus, press the ◀ and ▶ buttons in the numeric keypad.

Edge Type (Type) sub menu parameters

Operation	Knob	Parameter	Settings
Select the edge type.	F1	Typ (Type)	Normal: Normal edges Outline: Outline Extrude: Drop shadow Shadow: Shadow
Adjust the edge width.	F2	Wid (Width)	1 to 8
Adjust the edge softness (amount of blurring).	F3	Sft (Softness)	0.0 to 100.0

Operation	Knob	Parameter	Settings
When Extrude is selected, specify the edge direction. (Specify as a position corresponding to a number on the face of an analog clock.) Example: 3 corresponds to the direction from 3 o'clock.	F4	Dir (Direction)	0 to 11

Edge Color (Color) sub menu parameters

Operation	Knob	Parameter	Settings
Adjust the luminance of the edges.	F2	Lum (Luminance)	0.0 to 108.6
Adjust the saturation (color density) of the edges.	F3	Sat (Saturation)	0.0 to 100.0
Adjust the hue of the edges.	F4	Hue	0.0 to 359.5

Edge Position (Position) sub menu parameters

Operation	Knob	Parameter	Settings
When Shadow is selected, specify the X coordinate of the position where the shadow is added.	F2	PX (Position X)	-100.0 to 100.0
When Shadow is selected, specify the Y coordinate of the position where the shadow is added.	F3	PY (Position Y)	-100.0 to 100.0

Masking Downstream Keys with Box Masks

You can use the Box Mask sub menu of the Keyer menu to apply box masks to downstream keys.

To enable the Box Mask sub menu

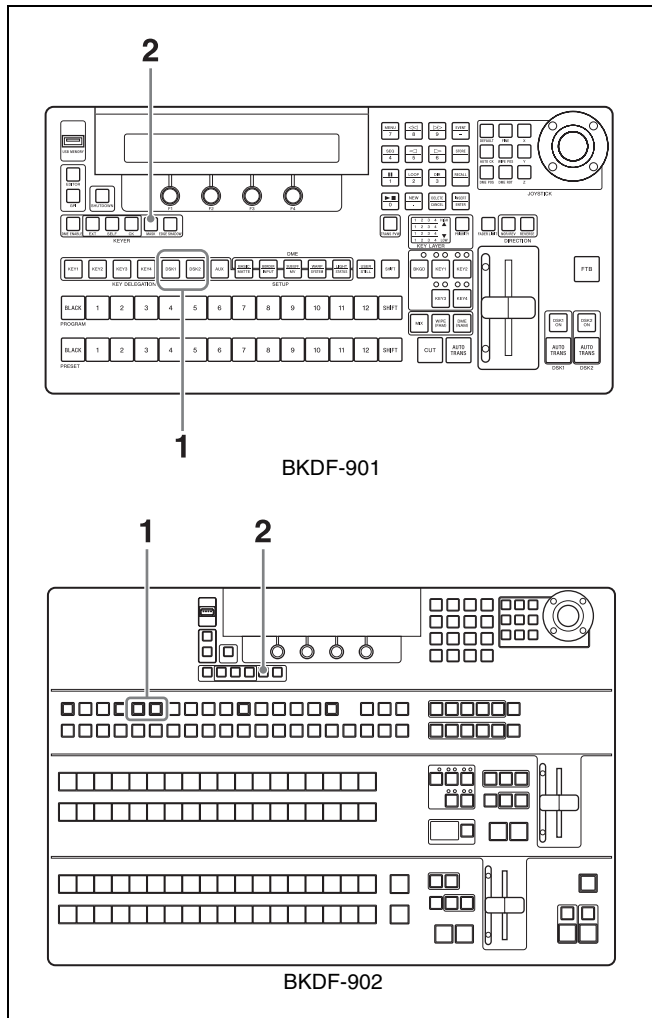

1 When using the **BKDF-901**: Depending on the key that you want to apply the box masks, press the DSK1 or DSK2 button in the KEY DELEGATION block, lighting it.

When using the BKDF-902: Depending on the key to which you want to apply the box masks, press the DSK1 or DSK2 button in the key/AUX bus control block, lighting it.

2 Press the MASK button in the KEYER block, lighting it.

Box mask is enabled, and the Box Mask sub menu appears in the display panel.

To adjust the position of the box mask

Adjust the parameters of the Box Mask sub menu.

Operation	Knob	Parameter	Settings
Specify the position of the left edge of the box mask.	F1	L (BoxMask Left)	0 to 1024
Specify the position of the right edge of the box mask.	F2	R (BoxMask Right)	0 to 1024
Specify the position of the top edge of the box mask.	F3	T (BoxMask Top)	0 to 1024
Specify the position of the bottom edge of the box mask.	F4	B (BoxMask Bottom)	0 to 1024

You can register a set of control panel settings as a single event, and then recall the settings simply by recalling the event. These settings include the selection of the background video, transition settings, key settings, and DME settings. You can register up to eight pages of events, with 12 events on each page, for a total of 96 events. You can also register sequences consisting of up to 31 keyframes, each of which represents a set of control panel settings for a single frame of video. Sequences allow you to transition gradually from the settings in one keyframe to the settings in the next keyframe, according to a specified interpolation mode. You can save up to 100 sequences. Use the Sequence Event menu (*see page 179*) for event and sequence operations.

Event Operations

Use the following procedures to register and recall the current control panel settings.

Registering Events

To register an event, make the control panel settings that you want to register, and then proceed as follows.

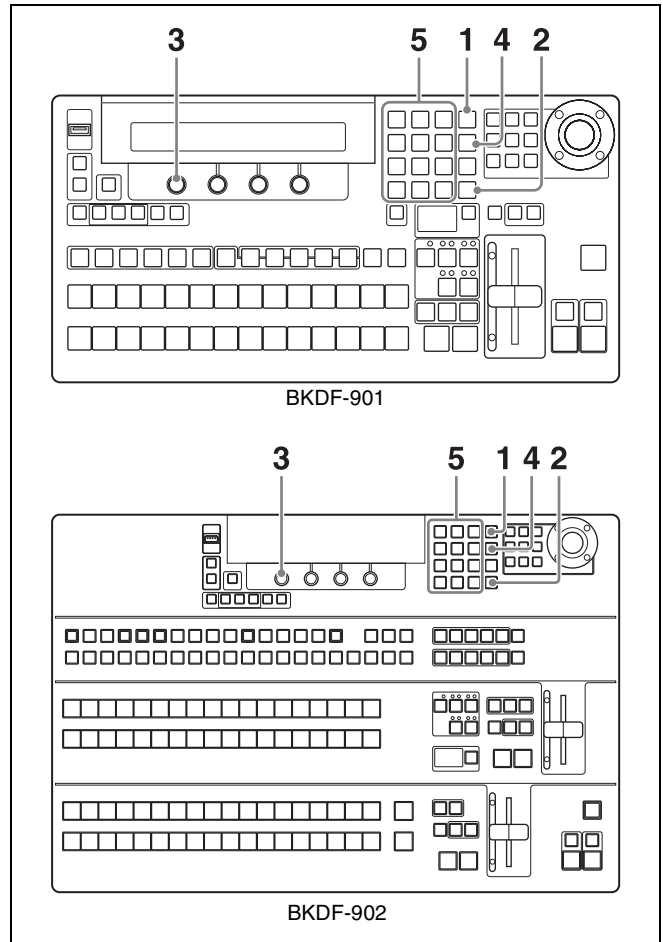

- 1 Press the EVENT button in the numeric keypad.

The numeric keypad enters event mode.

The 0 to 9, dot (.), and CANCEL buttons become event registration buttons, and buttons to which events have been registered light in green

The most recently used sub menu appears in the display panel.

- 2 If the INSERT button is lit, press it to turn it off.

The Event Data sub menu appears.

- 3 Rotate the F1 knob to select a page.

You can select a page from among the event pages P1 to P8.

- 4 Press the STORE button.

The button lights in red to indicate that the switcher has entered event storage mode.

- 5 Press the event registration button to which you want to register the current settings.

The current settings are stored in the memory of the control panel.

To save all event data to a USB flash drive

- 1 Carry out steps 1 and 2 of “Registering Events” (page 151).

- 2 Connect a USB flash drive to the USB MEMORY connector.

- 3 Press the F2 knob and hold it down for one second or longer.

All event data is stored to the USB flash drive.

Recalling Events

Use the following procedure to recall a stored event.

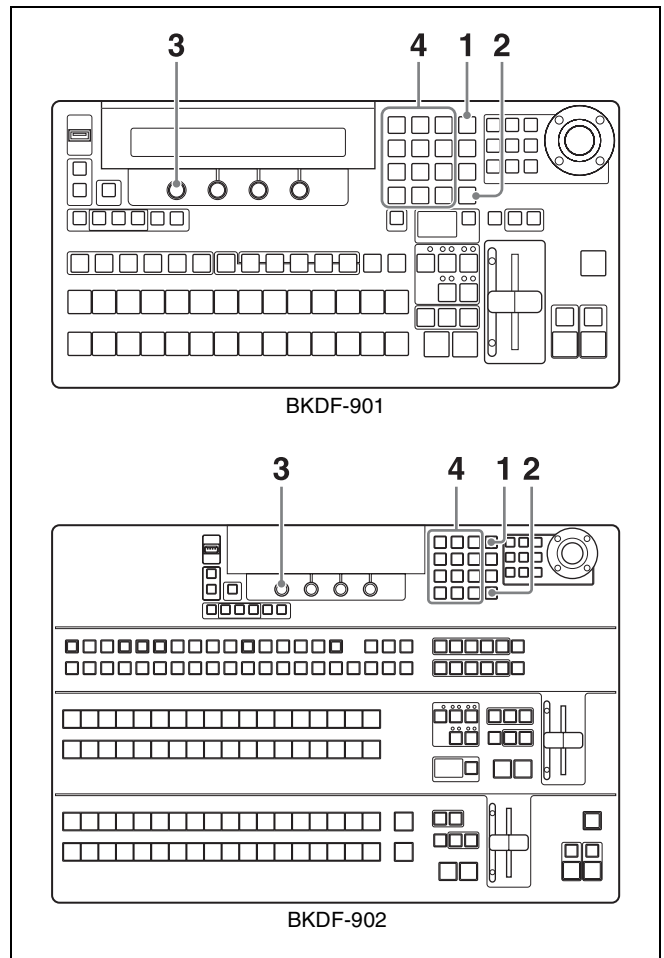

- 1 Press the EVENT button in the numeric keypad.

The numeric keypad enters event mode.

The RECALL button lights in red, and the 0 to 9, dot (.), and CANCEL buttons become event registration buttons. Buttons to which events have been registered light in green

The most recently used sub menu appears in the display panel.

You can also specify that only settings of a certain type should be recalled. For the operating procedure, see “To recall an event while specifying certain types of settings” (page 153).

- 2 If the INSERT button is lit, press it to turn it off.

The Event Data sub menu appears.

- 3 Rotate the F1 knob to select a page.

- 4 Press the event registration button to which the event that you want to recall has been assigned.

The event registered for the pressed button is recalled, and all of the settings in the event are restored on the control panel.

To recall an event while specifying certain types of settings

Use the following procedure if you want to recall an event but want to recall only certain types of settings instead of all settings registered in the event.

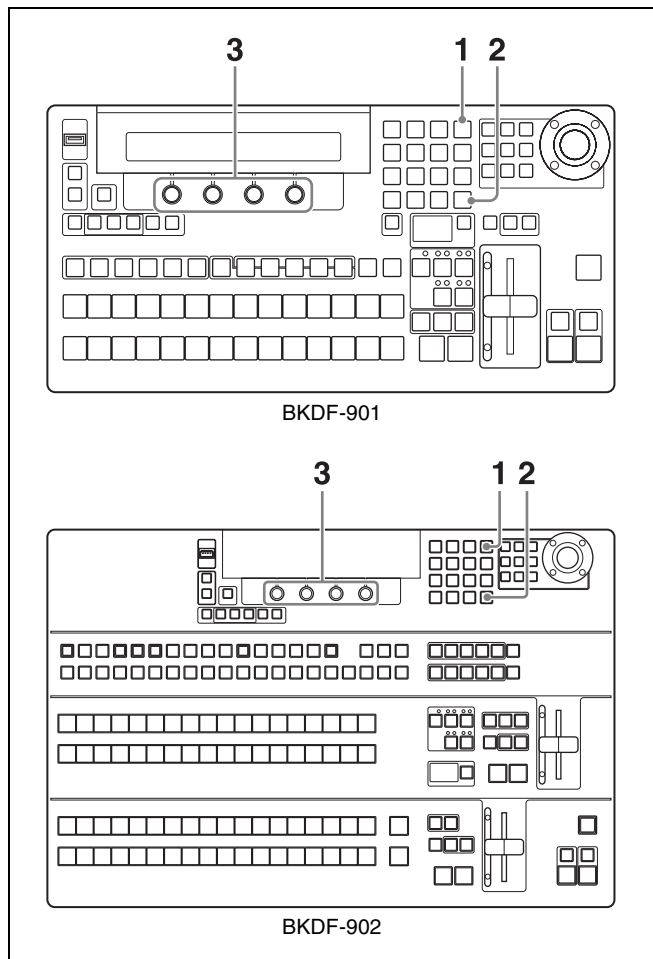

- 1** Press the EVENT button in the numeric keypad.
The numeric keypad enters event mode.
- 2** If the INSERT button is unlit, press it to turn it on.
The Event Target sub menu appears in the display panel.
- 3** Rotate the F1 to F4 knobs to select the types of settings to recall.

When using the BKDF-901

Knob	Parameter	Description	Settings
F1	BUS	M/E settings other than keyer settings	BUS On: Include M/E settings other than keyer settings BUS Off: Do not include M/E settings other than keyer settings P-P Hold: Include settings other than keyer settings and PROGRAM/PRESET settings
F2	Keyer	Keyer settings	Keyer On: Include keyer settings Keyer Off: Do not include keyer settings
F3	DSK	DSK settings	DSK On: Include DSK settings DSK Off: Do not include DSK settings
F4	Still	Still settings ^{a)}	Still Off: Do not include Still settings Still On: Still1 to Still4 settings Still1: Still1 settings only Still2: Still2 settings only Still3: Still3 settings only Still4: Still4 settings only

a) The data registered in the event is the file numbers of the images in Still1 to Still4 memory. Image data is not registered.

When using the BKDF-902

Knob	Parameter	Description	Settings
F1	BUS	M/E settings other than keyer settings, and PROGRAM/PRESET settings	<p>BUS On: Include M/E settings other than keyer settings, and PROGRAM/PRESET settings</p> <p>BUS Off: Do not include M/E settings other than keyer settings, and PROGRAM/PRESET settings</p> <p>ME On: Include M/E settings only</p> <p>PP On: Include PROGRAM/PRESET settings only</p> <p>P-P Hold: Include settings other than PROGRAM/PRESET settings</p>
F2	Keyer	Keyer settings	<p>Keyer On: Include keyer settings</p> <p>Keyer Off: Do not include keyer settings</p>
F3	DSK	DSK settings	<p>DSK On: Include DSK settings</p> <p>DSK Off: Do not include DSK settings</p>
F4	Still	Still settings ^{a)}	<p>Still Off: Do not include Still settings</p> <p>Still On: Include Still1 to Still4 settings</p> <p>Still1: Include Still1 settings only</p> <p>Still2: Include Still2 settings only</p> <p>Still3: Include Still3 settings only</p> <p>Still4: Include Still4 settings only</p>

a) The data registered in the event is the file numbers of the images in Still1 to Still4 memory. Image data is not registered.

- 4 Carry out steps 2 and following of “Recalling Events” (page 152).

The event registered for the pressed button is recalled. From among the settings in the event, only those settings that were specified in step 3 are restored on the control panel.

Note

The type selections made in step 3 are retained until the control panel is powered off. They are applied to all subsequent event recalls. If you want to recall different types of settings, carry out the procedure again from steps 1 through 4.

To recall all event data from a USB flash drive

- 1 Carry out steps 1 and 2 of “Recalling Events” (page 152).
- 2 Connect the USB flash drive that contains the data that you want to recall to the USB MEMORY connector.
- 3 Rotate the F3 knob to select USB as the storage location of the data that you want to recall.
- 4 Press the F3 knob and hold it down for one second or longer.

All event data is recalled.

To recall events in page units from the USB flash drives

You can recall multiple events at once by recalling them in page units.

To recall events in page units, use the F1 knob instead of the F3 knob in step 3 of “To recall all event data from a USB flash drive” (page 154). Rotate the F1 knob to select the page, and then, with the SHIFT button in the DME/SETUP block (when using the BKDF-901) or the KEY SRC button in the key/AUX bus control block (when using the BKDF-902) held down, press the F3 knob and hold it down for one second or longer.

The events on the specified page are recalled.

Deleting Events

Use the following procedure to delete registered events.

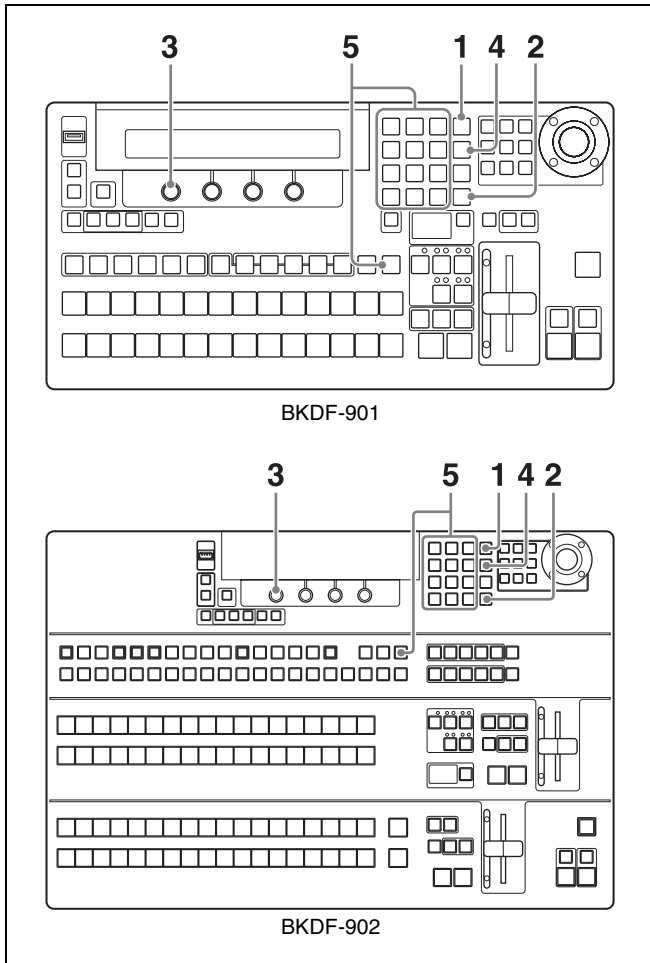

- 1** Press the EVENT button in the numeric keypad.
The numeric keypad enters event mode.
The most recently used sub menu appears in the display panel.
- 2** If the INSERT button is lit, press it to turn it off.
The Event Data sub menu appears.
- 3** Rotate the F1 knob to select a page.
- 4** Press the STORE button.
- 5** With the SHIFT button in the DME/SETUP block (when using the BKDF-901) or the KEY SRC button in the key/AUX bus control block (when using the BKDF-902) held down, press the event registration button to which the event that you want to delete has been assigned.

The button changes from lit in green to not lit, and the event registered for that button is deleted.

To delete events in page units

You can delete multiple registered events at once by deleting them in page units.

In event mode, select a page, and then press the F4 (Initial) knob and hold it down for one second or longer.

To recall events from an editor

Setting the communications protocol to GVG100 (see page 162) allows specifying an E-FILE (event file) number to recall individual events from the BVE-2000. The following figure shows the correspondence between the events on each page and E-FILE numbers, using the arrangement of buttons on the numeric keypad.

Numeric keypad			Event					
			Page	P1	P2	P3	P4	P5
7	8	9	E-FILE	50 51 52	62 63 64	74 75 76	86 87 88	98
4	5	6		53 54 55	65 66 67	77 78 79	89 90 91	
1	2	3		56 57 58	68 69 70	80 81 82	92 93 94	
0	New	Del		59 60 61	71 72 73	83 84 85	95 96 97	

Events numbers 50 to 98 can be specified from the BVE-2000. (The BVE-2000 can operate numbers up to 99, but number 99 is reserved for “Init Panel”).

On how to use the BVE-2000, refer to the User’s Guide supplied with the BVE-2000.

Sequence Operations

You can register a series of video settings as a sequence. Use the following procedure.

Creating Sequences

Use the following procedure to create a sequence.

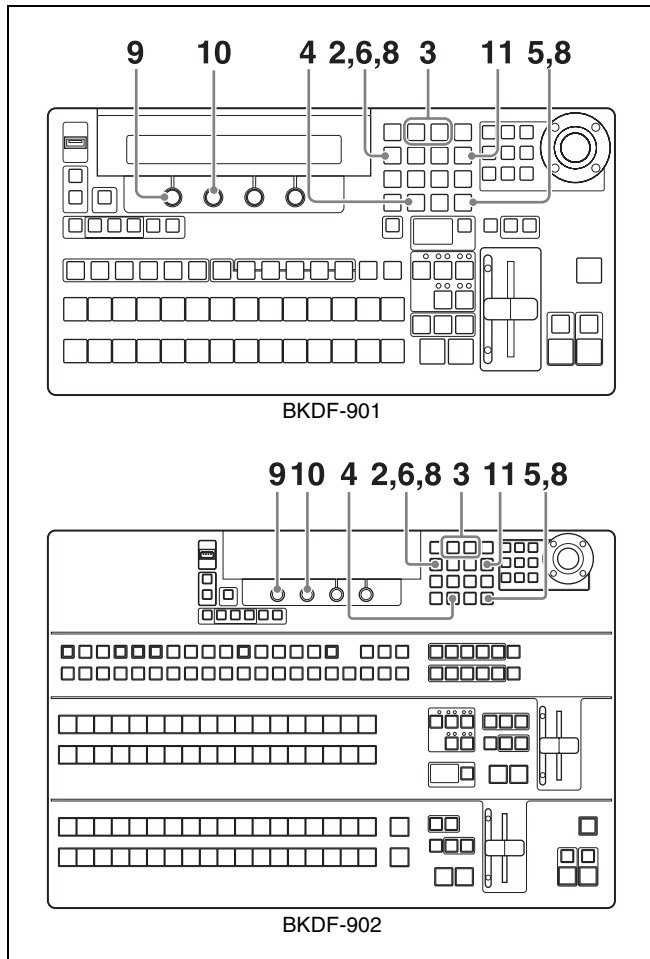

1 Create the video that you want to register as the first keyframe in the sequence.

Registering the desired video as an event in advance may be convenient, because it allows you to restore a set of video settings to the control panel simply by recalling the event.

2 Press the SEQ button in the numeric keypad.

The numeric keypad enters sequence mode. The most recently used sub menu appears in the display panel.

3 Press the << and >> buttons in the numeric keypad until the Seq File sub menu appears.

4 Press the NEW button.

Sequence memory is cleared.

5 Press the INSERT button.

The current control panel settings are registered as the first keyframe of the sequence.

6 Press the SEQ button.

The numeric keypad exits sequence mode.

7 Create the video that you want to register as the next keyframe.

8 Press the SEQ button again to switch to sequence mode, and then press the INSERT button.

The video created in step 7 is registered as the next keyframe.

Repeat steps 6 to 8 to register all of the keyframes that you want in the sequence.

9 Rotate the F1 knob to select the file in which you want to save the sequence.

You can select file numbers from 00 to 99.

10 Rotate the F2 knob to select the sequence storage destination.

You can select either the switcher control panel (CP) or a USB flash drive.

11 Press the STORE button.

The sequence is stored in the selected file in the selected storage destination.

Recalling Sequences

Use the following procedure to recall a sequence that you have created.

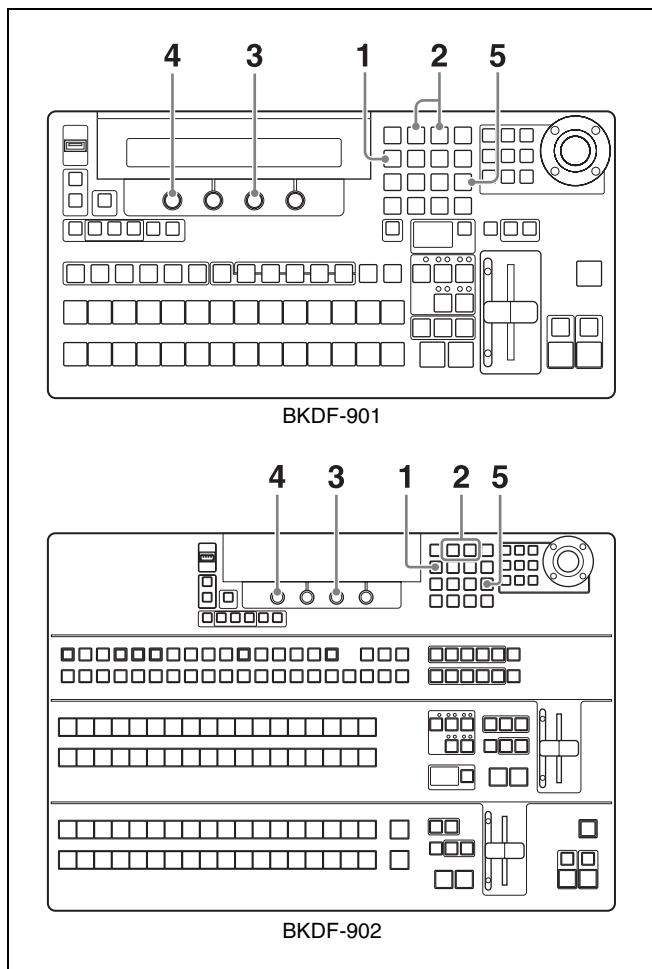

To display the video of the first keyframe when a sequence is recalled

The normal procedure for recalling a sequence does not recall the video of the first keyframe. If you want to display the video of the first keyframe when a sequence is recalled, proceed as follows.

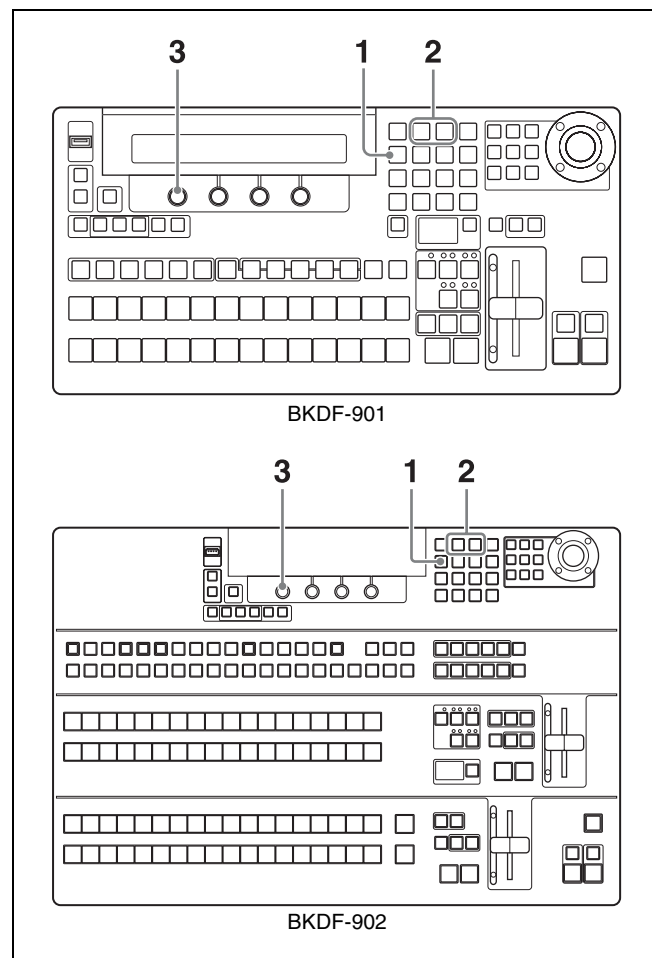

- 1** Press the SEQ button in the numeric keypad.
The numeric keypad enters sequence mode. The most recently used sub menu appears in the display panel.
- 2** Press the << and >> buttons in the numeric keypad until the Seq File sub menu appears.
- 3** Rotate the F3 knob to select the storage destination of the sequence that you want to recall.
You can select either the switcher control panel (CP) or a USB flash drive.
- 4** Rotate the F1 knob to select the file that contains the sequence that you want to recall.
Tip
An asterisk (*) appears after the number of file that contains a sequence.
- 5** Press the RECALL button.
The sequence in the selected file is recalled.

- 1** Press the SEQ button in the numeric keypad.
The numeric keypad enters sequence mode. The most recently used sub menu appears in the display panel.
- 2** Press the << and >> buttons in the numeric keypad until the Seq Setup sub menu appears.
- 3** Rotate the F1 knob to specify whether to recall the first keyframe.
Onl (Only Recall): Do not recall the first keyframe.
Rew (Recall+Rewind): Recall the first keyframe.

To replace the current video settings with the settings of a registered sequence

Before recalling the sequence, proceed as follows.

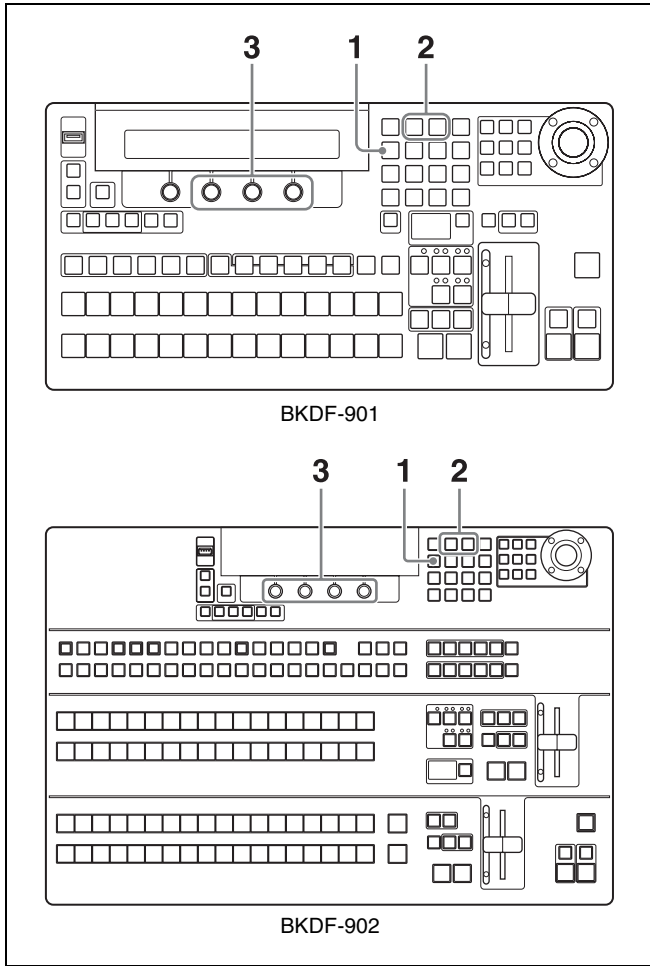

- 1** Press the SEQ button in the numeric keypad.
The numeric keypad enters sequence mode. The most recently used sub menu appears in the display panel.
- 2** Press the << and >> buttons in the numeric keypad until the Seq Setup sub menu appears.
- 3** Rotate the F2, F3, and F4 knobs to select whether to change M/E, keyer, and DSK settings when the sequence is played.

When using the BKDF-901

Knob	Parameter	Description	Settings
F2	BUS	M/E settings other than keyer settings	On: Do not change the current settings.
F3	Keyer	Keyer settings	Off: Replace the current settings with the sequence settings.
F4	DSK	Downstream key settings	

When using the BKDF-902

Knob	Parameter	Description	Settings
F2	BUS	M/E settings other than keyer settings, and PROGRAM/PRESET settings	<p>BUS Off: Replace M/E, and PROGRAM/PRESET settings with the sequence settings.</p> <p>BUS On: Do not change M/E, and PROGRAM/PRESET settings.</p> <p>ME On: Do not change the current M/E settings. Replace PROGRAM/PRESET settings with the sequence settings.</p> <p>PP On: Do not change the current PROGRAM/PRESET settings. Replace M/E settings with the sequence settings.</p>
F3	M/E	Keyer settings	On: Do not change the current settings. Off: Replace the current settings with the sequence settings.
F4	DSK	DSK settings	

When a sequence is recalled, the settings of the recalled sequence are reflected, but they are reflected to the currently displayed video instead of to the video that was selected at the time when the sequence was registered.

Playing Sequences

You can use the following four buttons in the numeric keypad to play a sequence after recalling it.

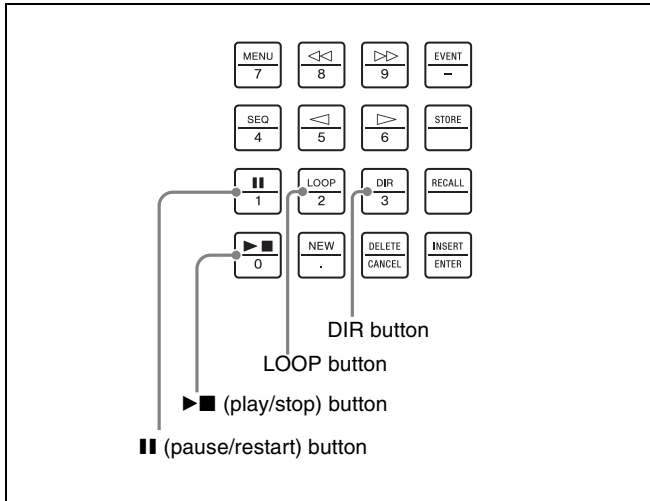

- || (pause/restart) button:** Pauses play when pressed during play, and restarts play from the paused position when pressed again.
- ▶■ (play/stop) button:** Starts play when pressed, and stops play when pressed again.
- LOOP button:** Selects loops play. If you want loop play, press this button to light it before starting play.
- DIR button:** Reverses the play direction.

Editing Sequences

After recalling a sequence, you can edit it by changing parameters and by adding or deleting keyframes.

To change parameters

Use the Seq Edit sub menu to change parameters.

To display the Seq Edit sub menu

Press the SEQ button in the numeric keypad. The most recently used sub menu appears in the display panel. Press the <<< and >>> buttons in the numeric keypad until the Seq Edit sub menu appears.

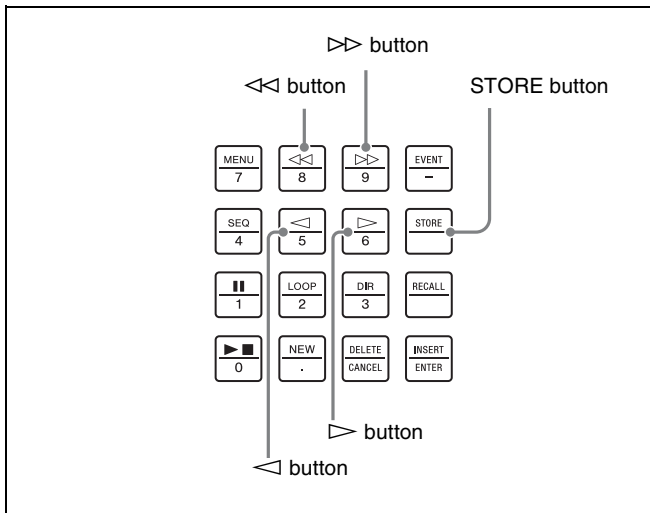

The Seq Edit sub menu displays the total number of keyframes (Total) registered in the currently recalled sequence, and the number of the current keyframe (Cur). The current keyframe is the keyframe at the current display position. You can press the < and > buttons to move the current keyframe.

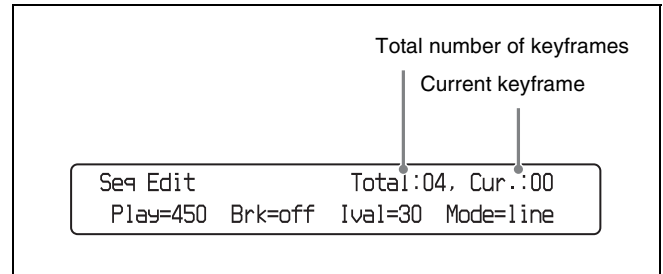

The following parameters can be changed.

Knob	Parameter	Description	Settings
F1	Play ^{a)}	Sequence execution (play) time	1 to 3200
F2	Brk ^{b)}	Pause at each keyframe	On, Off
F3	Ival ^{a)}	Interval	1 to 999
F4	Mode	Interpolation mode	Point, Line, Curve

- a) The interval is a relative value with respect to the execution time. It changes whenever the execution time changes.
- b) Setting this to On results in a pause between individual keyframes, which is convenient if you want to add or delete keyframes.

When you have finished changing parameters, press the STORE button to save the changes.

Note

Unless you save them, changes to parameters are lost when the switcher is powered off. Always save the sequence whenever you change sequence parameters.

For information about how to save sequences, see "Creating Sequences" (page 156).

To add keyframes

You can add new keyframes at any point in a sequence. To add a keyframe, recall a sequence and then proceed as follows.

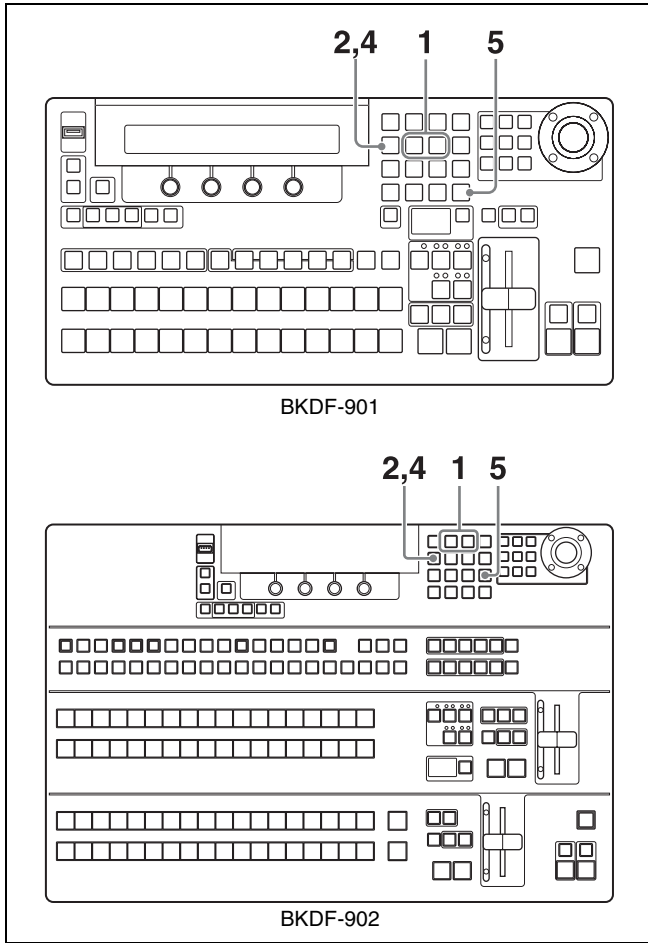

- 1** Press the ◀ and ▶ buttons to move to the point where you want to add a keyframe.
If you want to add a new keyframe at the end of the sequence, move to the last current keyframe.
- 2** Press the SEQ button in the numeric keypad.
The switcher exits sequence mode.
- 3** Create the video that you want to add as a keyframe.
- 4** Press the SEQ button again to switch to sequence mode.
- 5** Press the INSERT button.
The newly created video is added as a new keyframe, and the keyframe that was previously at that position is shifted toward the end of the sequence, along with all subsequent keyframes.

To delete keyframes

To delete a keyframe from a sequence, recall the sequence and then proceed as follows.

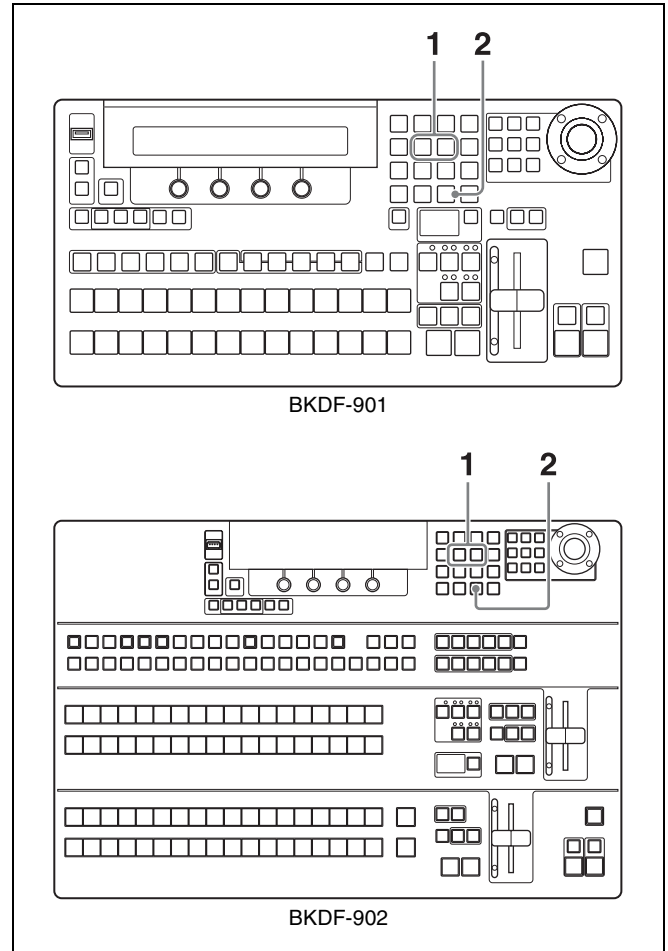

- 1** Press the ◀ and ▶ buttons to move to the position of the keyframe that you want to delete.
- 2** Press the DELETE button.

Deleting Sequences

To delete a stored sequence, recall that sequence and then press the F4 knob and hold it down for one second or longer.

Serial Interface Settings

Before connecting an editor or AUX bus remote controller, you must set up the serial interface by making communication settings.

To make communication settings, use the Serial sub menu of the Setup menu. The Serial sub menu has the following sub menus.

Sub menu	Operation
Protocol	Set the communication protocol
Baudrate	Set the baud rate
Parity	Set the parity bit

To show the sub menus

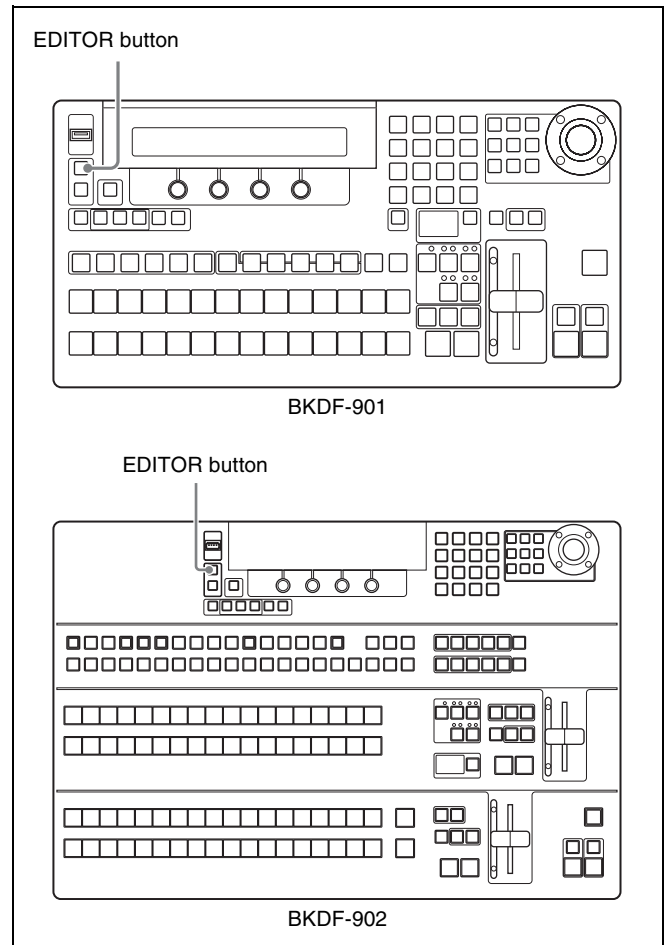

In the External Connections and Power block, press the EDITOR button twice in quick succession.

The most recently used sub menu appears in the display panel.

To switch between sub menus, press the ◀ and ▶ buttons in the numeric keypad.

Note

Always make the communication settings in these sub menus before connecting a serial communications device.

Communications Protocol Settings

Adjust the following parameters in the Protocol sub menu to specify the communications protocol.

Knob	Parameter	Description	Settings ^{a)}
F1	1	RS-422A, port 1	Specify the serial communications device to be connected from among the following: GVG100, BVS3000, HVS-AUX
F2	2	RS-422A, port 2	GVG100, BVS3000, HVS-AUX
F3	3	RS-422A, port 3	GVG100, BVS3000, HVS-AUX
F4	4	RS-422A, port 4 (editor)	GVG100, BVS3000, HVS-AUX

a) For each parameter, rotate the corresponding knob to select the serial communications device to be connected. Select "---" if you do not want to select a device.

Knob	Parameter	Description	Settings
F4	4	RS-422A, port 4 (editor)	None: Do not use a parity bit Odd: Odd parity Even: Even parity

Baud Rate Settings

Adjust the following parameters in the Baudrate sub menu to set the baud rate.

Knob	Parameter	Description	Settings
F1	1	RS-422A, port 1	9600, 19200, 38400
F2	2	RS-422A, port 2	9600, 19200, 38400
F3	3	RS-422A, port 3	9600, 19200, 38400
F4	4	RS-422A, port 4 (editor)	9600, 19200, 38400

Parity Bit Settings

Adjust the following parameters in the Parity sub menu to set the parity bit.

Knob	Parameter	Description	Settings
F1	1	RS-422A, port 1	None: Do not use a parity bit Odd: Odd parity Even: Even parity
F2	2	RS-422A, port 2	None: Do not use a parity bit Odd: Odd parity Even: Even parity
F3	3	RS-422A, port 3	None: Do not use a parity bit Odd: Odd parity Even: Even parity

GPI Input Settings

You can use GPI input signals to control the switcher from other devices. Pins 1 to 6 of the GPI IN connector are for GPI input. You can assign GPI input signals to these pins to control the functions listed below.

For more information about the pins of the GPI IN connector, see “Pin Assignments” (page 211). For more information about signal connection, see “Example Connection of GPI Input” (page 214).

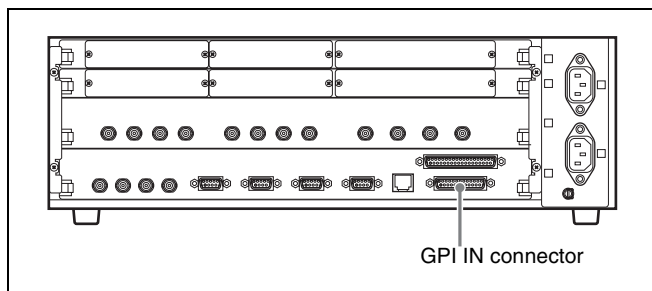

- M/E Trn: Execute an M/E transition.
- M/E Cut: Execute an M/E cut transition.
- M/E Mix: Change the M/E transition type to mix.
- M/E Wipe: Change the M/E transition type to wipe.
- M/E DME: Change the M/E transition type to DME wipe.
- M/E FAM: Change the M/E transition type to full-additive mix.
- M/E NAM: Change the M/E transition type to non-additive mix.
- P/P Trn: Execute a PROGRAM/PRESET transition (only when using the BKDF-902).
- P/P Cut: Execute a PROGRAM/PRESET cut transition (only when using the BKDF-902).
- P/P Mix: Change the PROGRAM/PRESET transition type to mix (only when using the BKDF-902).
- P/P Wipe: Change the PROGRAM/PRESET transition type to wipe (only when using the BKDF-902).
- DSK 1 Cut: Execute a DSK 1 cut transition.
- DSK 1 Mix: Execute a DSK 1 mix transition.
- DSK 2 Cut: Execute a DSK 2 cut transition.
- DSK 2 Mix: Execute a DSK 2 mix transition.
- FTB: Execute a fade to black.
- SEQ Play: Play a sequence.

To change GPI input settings

Use the GPI sub menu.

To display the GPI sub menu

In the External Connections and Power Block, press the GPI button twice in quick succession.

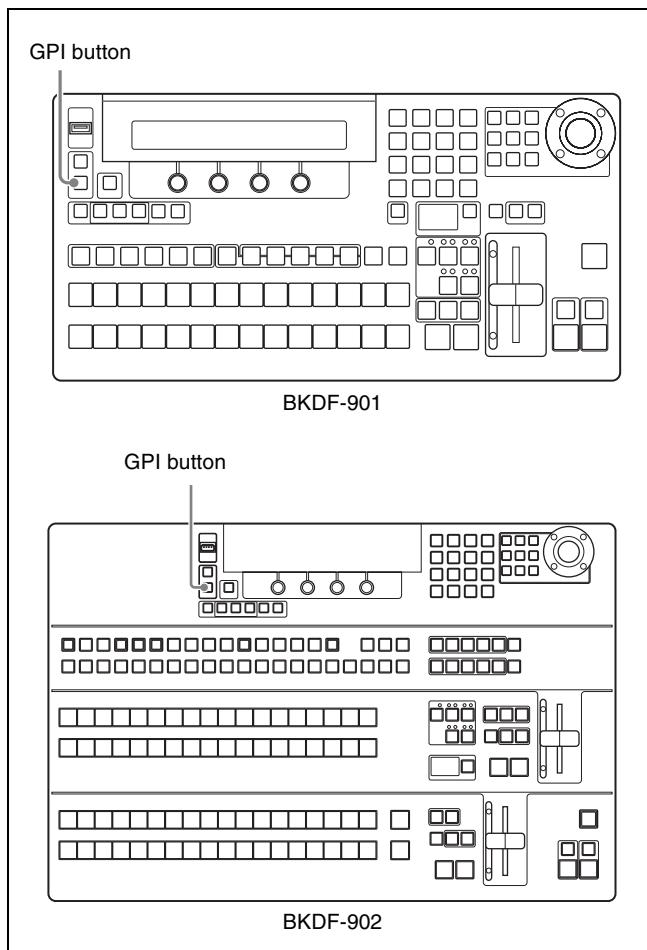

The most recently used sub menu appears in the display panel.

To switch between sub menus, press the ◀ and ▶ buttons in the numeric keypad.

To change settings

Adjust the following parameters.

When using the BKDF-901

Knob	Parameter	Description	Settings
F1	GPI	GPI input pin number	1 to 16
F2	F	GPI input function	M/E Trn, M/E Cut, M/E Mix, M/E Wipe, M/E DME, M/E FAM, M/E NAM, DSK1 Cut, DSK1 Mix, DSK2 Cut, DSK2 Mix, FTB, SEQ Play

When using the BKDF-902

Knob	Parameter	Description	Settings
F1	GPI	GPI input pin number	1 to 16

Knob	Parameter	Description	Settings
F2	F	GPI input function	M/E Trn, M/E Cut, M/E Mix, M/E Wipe, M/E DME, M/E FAM, M/E NAM, P/P Trn, P/P Cut, P/P Mix, P/P Wipe, DSK1 Cut, DSK1 Mix, DSK2 Cut, DSK2 Mix, FTB, SEQ Play

Tally Output Settings

This switcher can output 32 different tally signals. You can assign the following tally output signals to tally/GPI output pins of the TALLY/GPI OUT connector.

For more information about the pins of the TALLY/GPI OUT connector, see “Pin Assignments” (page 211). For more information about signal connection, see “Example Connection of Tally/GPI Output” (page 214).

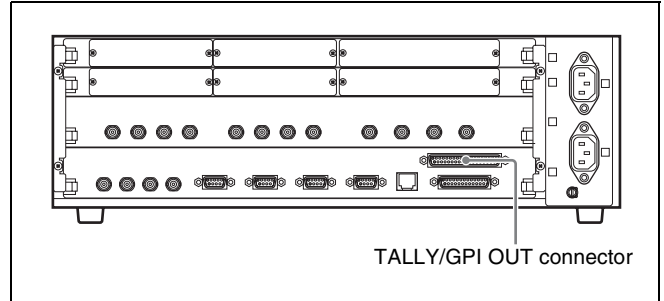

- R-BLK: Red tally to BLACK
- R-In01 to 24: Red tally to In01 to In24
- R-Stl1 to 4: Red tally to Stl1 to Stl4
- R-Mat1 to 4: Red tally to Mat1 to Mat4
- R-Rsv01 to R-Rsv07 (or 06)¹⁾: Reserved for future expansion
- R-ME: Red tally to M/E (only when using the BKDF-902)
- G-BLK: Green tally to BLACK
- G-In01 to 24: Green tally to In01 to In24
- G-Stl1 to 4: Green tally to Stl1 to Stl4
- G-Mat1 to 4: Green tally to Mat1 to Mat4
- G-Rsv01 to G-Rsv06 (or 05)²⁾: Reserved for future expansion
- Play: See “To set the GPI output” (page 166)
- G-ME: Green tally to M/E (only when using the BKDF-902)
- Alarm: Alarm

1) When using the BKDF-901: R-Rsv01 to R-Rsv07

When using the BKDF-902: R-Rsv01 to R-Rsv06

2) When using the BKDF-901: G-Rsv01 to G-Rsv06

When using the BKDF-902: G-Rsv01 to G-Rsv05

To change tally output settings

Use the Tally sub menu.

To display the Tally sub menu

In the External Connections and Power Block, press the GPI button twice in quick succession.

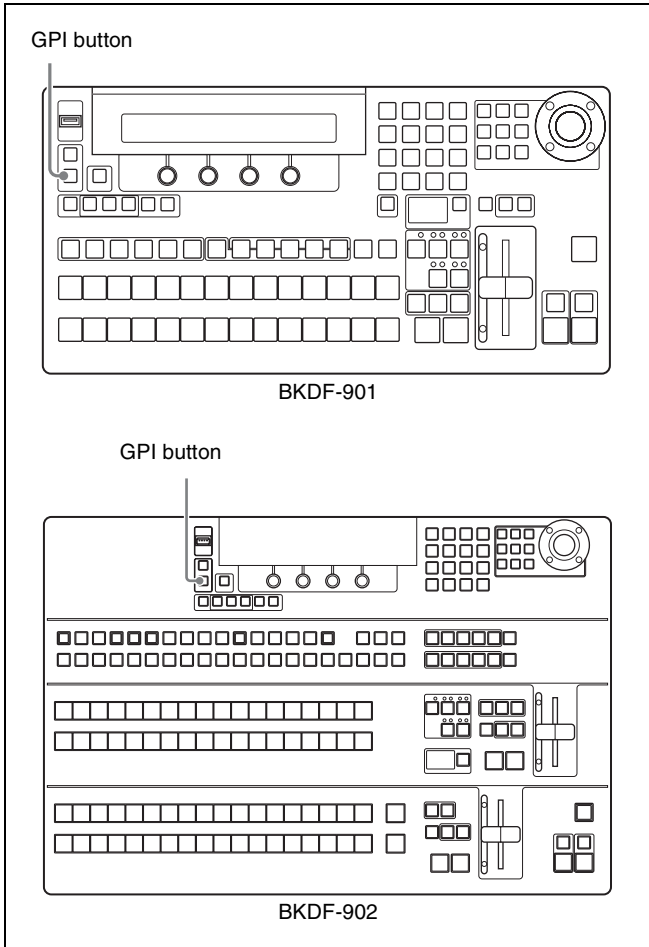

Knob	Parameter	Description	Settings
F2	F	Tally type	R-Blk, R-In01 to R-In24, R-Stl1 to R-Stl4, R-Mat1 to R-Mat4, R-Rsv01 to R-Rsv06, R-ME, G-Blk, G-In01 to G-In24, G-Stl1 to G-Stl4, G-Mat1 to G-Mat4, GRsv01 to GRsv05, Play, G-ME, Alarm

The most recently used sub menu appears in the display panel.

To switch between sub menus, press the ◀ and ▶ buttons in the numeric keypad.

To change settings

Adjust the following parameters.

When using the BKDF-901

Knob	Parameter	Description	Settings
F1	Tally	Tally output pin number	1 to 32
F2	F	Tally type	R-Blk, R-In01 to R-In24, R-Stl1 to R-Stl4, R-Mat1 to R-Mat4, R-Rsv01 to R-Rsv07, G-Blk, G-In01 to G-In24, G-Stl1 to G-Stl4, G-Mat1 to G-Mat4, G-Rsv01 to G-Rsv06, Play, Alarm

When using the BKDF-902

Knob	Parameter	Description	Settings
F1	Tally	Tally output pin number	1 to 32

GPI Output Settings

This switcher can output GPI signals from the TALLY/GPI OUT connector. You can use the GPI output for timing control when you capture images from a playback device for keying.

For more information about the pins of the TALLY/GPI OUT connector, see “Pin Assignments” (page 211). For more information about signal connection, see “Example Connection of Tally/GPI Output” (page 214).

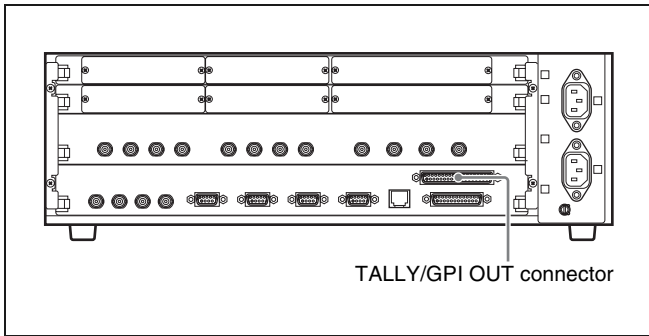

To set the GPI output

Use the Tally sub menu to select a pin from 32 pins of the TALLY/GPI OUT connector and assign “Play” function. Rotate the F1 knob to select the pin number, and rotate the F2 knob to select Play.

For more information about the Tally sub menu, see “To change tally output settings” (page 164).

Backing Up Data

You can use the Data Backup sub menu of the Setup menu to back up, recall, and clear the various types of data used by the switcher.

Backup or recall: Save backup data to a USB flash drive connected to the USB MEMORY connector, or recall the data as required.

Clear: Clear the data saved in the USB flash drive connected to the USB MEMORY connector or in the memory of the control panel.

The following types of data can be targeted.

- All data: System data and file data
- System data: Data such as events, I/O settings, initial values, and status data
- File data: Still image file data stored in the control panel, user pattern data, and sequence data.

To back up, recall, and clear data, use sub menus of the Data Backup sub menu.

Sub menu	Operation
All Backup	Back up, recall, and clear all data
System Backup	Back up, recall, and clear system data
File Backup	Back up, recall, and clear file data

To display the Data Backup sub menus

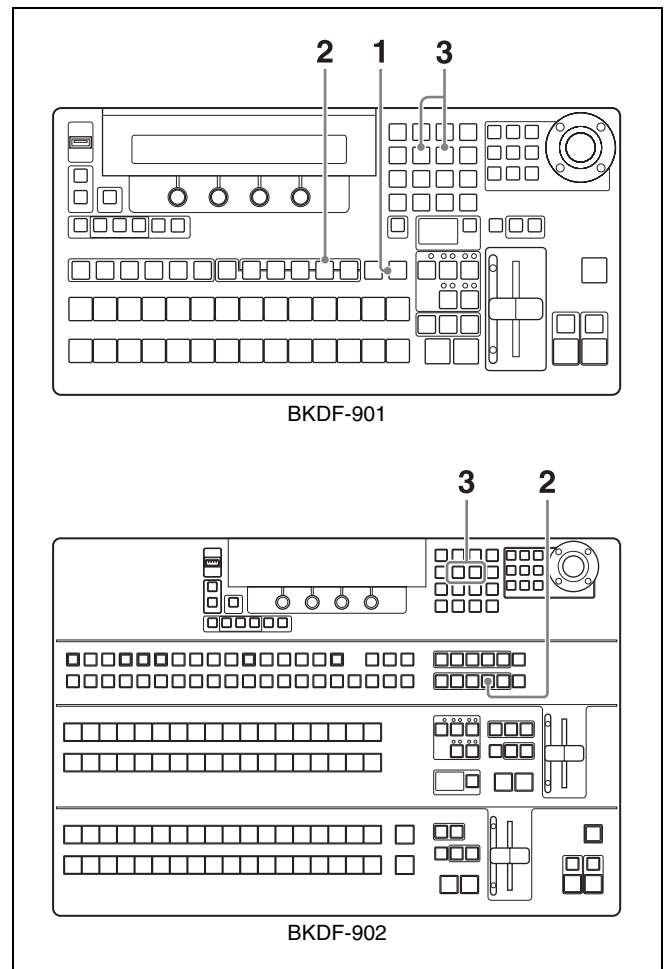

1 When using the BKDF-901: If the SHIFT button in the DME/SETUP block is not lit, press it to light it.

When using the BKDF-902: Skip to step 2.

2 Press the SYSTEM button.

The most recently used sub menu appears in the display panel.

- 3** Press the ◀ and ▶ buttons in the numeric keypad until the desired sub menu appears.

Backing Up, Restoring, and Clearing All Data

In the All Backup sub menu, check the following parameters and then execute the backup.

Knob	Parameter	Description	Settings
F1	Store	Back up all data	USB
F2	Recall	Recall all data	USB
F4	Clear	Clear all data	CP

To back up all data to a USB flash drive

Connect a USB flash drive, and then press the F1 knob and hold it down for one second or longer.

Note

If there is not enough free memory on the USB flash drive, the backup is cancelled and an error message appears.

To recall all data from a USB flash drive

Connect a USB flash that contains the backup data, and then press the F2 knob and hold it down for one second or longer.

To clear all data from the memory of the control panel

Press the F4 knob and hold it down for one second or longer.

Backing Up, Restoring, and Clearing System Data

In the System Backup sub menu, set the following parameters, and then execute the backup.

To back up all data to a USB flash drive

Knob	Parameter	Description	Settings
F1	Store	Backup system data	USB
F2	Recall	Recall system data	USB
F3	No	System data management number	Sys0 to Sys9
F4	Clear	Clear system data	USB

To back up system data to a USB flash drive

Connect a USB flash drive, rotate the F3 knob to select a system data management number (Sys0 to Sys9), and then

press the F1 knob and hold it down for one second or longer.

Notes

- If there is not enough free memory on the USB flash drive, the backup is cancelled and an error message appears.
- The backup file names corresponding to the ten system management numbers Sys0 to Sys9 are the ten file names “a” to “j”.
- An asterisk (*) appears beside a system management number when backup data under that number already exists on the USB flash drive. If you select a number with an asterisk, the existing data is overwritten when you press the F1 knob and hold it down for one second or longer.

To recall system data from a USB flash drive

Connect a USB flash that contains backup system data, rotate the F3 knob to select a system data management number (Sys0 to Sys9), and then press the F2 knob and hold it down for one second or longer.

To clear system data from a USB flash drive

Connect a USB flash that contains backup system data, rotate the F3 knob to select a system data management number (Sys0 to Sys9), and then press the F4 knob and hold it down for one second or longer.

Backing Up, Restoring, and Clearing File Data

In the File Backup sub menu, set the following parameters, and then execute the backup.

Knob	Parameter	Description	Settings
F1	Store	Backup file data	USB
F2	Recall	Recall file data	USB
F3	Type	File data type	Stl, Seq, Usr
F4	Clear	Location where data to be cleared is stored	USB, CP

To back up file data to a USB flash drive

Connect a USB flash drive and then proceed as follows.

- 1 Rotate the F3 knob to select the type of file data.

Stl: Data saved as still image files

Seq: Data saved as sequence files

Usr: User pattern data

- 2 Press the F1 knob and hold it down for one second or longer.

Note

If there is not enough free memory on the USB flash drive, the backup is cancelled and an error message appears.

To recall backup file data from a USB flash drive

Connect a USB flash that contains backup file data and then proceed as follows.

- 1 Rotate the F3 knob to select the type of file data.

Stl: Data saved as still image files

Seq: Data saved as sequence files

Usr: User pattern data

- 2 Press the F2 knob and hold it down for one second or longer.

To clear file data from a USB flash drive or control panel memory

- 1 Rotate the F3 knob to select the type of file data.

Stl: Data saved as still image files

Seq: Data saved as sequence files

Usr: User pattern data

- 2 Rotate the F4 knob to select the memory that you want to clear.

USB: USB flash drive connected to the USB MEMORY connector

CP: Memory of the switcher's control panel

- 3 Press the F4 knob and hold it down for one second or longer.

Updating the System

Use the Update sub menu of the Setup menu to update the system software, and to turn the display panel cursor icon on or off.

To display the Update sub menu

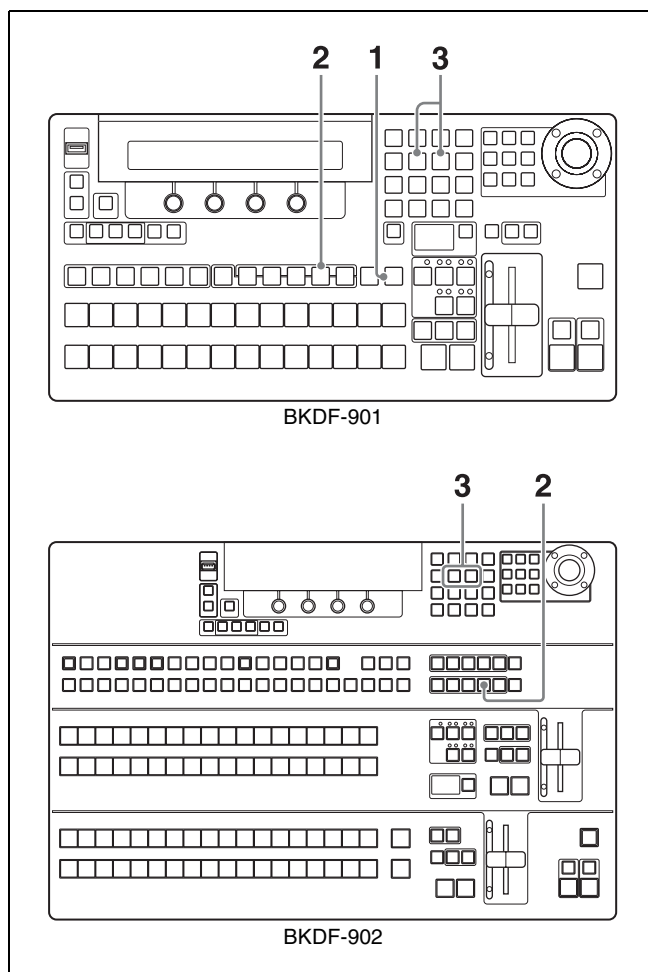

- 1 **When using the BKDF-901:** If the SHIFT button in the DME/SETUP block is not lit, press it to light it.

When using the BKDF-902: Skip to step 2.

- 2 Press the SYSTEM button.

The most recently used sub menu appears in the display panel.

- 3 Press the ◀ and ▶ buttons in the numeric keypad until the Update sub menu appears.

To update the system

In the Update sub menu, adjust the following parameters, and then execute the operation.

Knob	Parameter	Description	Settings
F1	CP	Update the control panel software.	–
F3	TG	Update firmware.	DSP, CPU, Main_IO, XPT, KEYSER, Comb, DME, MV, SDI_I, SDI_O AI ^{a)} , AO ^{a)} , DVI_I ^{a)} , DVI_O ^{a)}
F4	Cursor	Turn the GUI menu cursor on or off.	–

a) Reserved for future expansion

To display or hide the GUI menu cursor

Press the F4 knob and hold it down for one second or longer.

To update the software from the Update sub menu

For information about software updates contact a Sony service representative.

Status Information

The Status sub menu of the Setup menu allows you to check alarms, software versions, and the status of the option boards installed in the switcher.

To display the Status sub menus

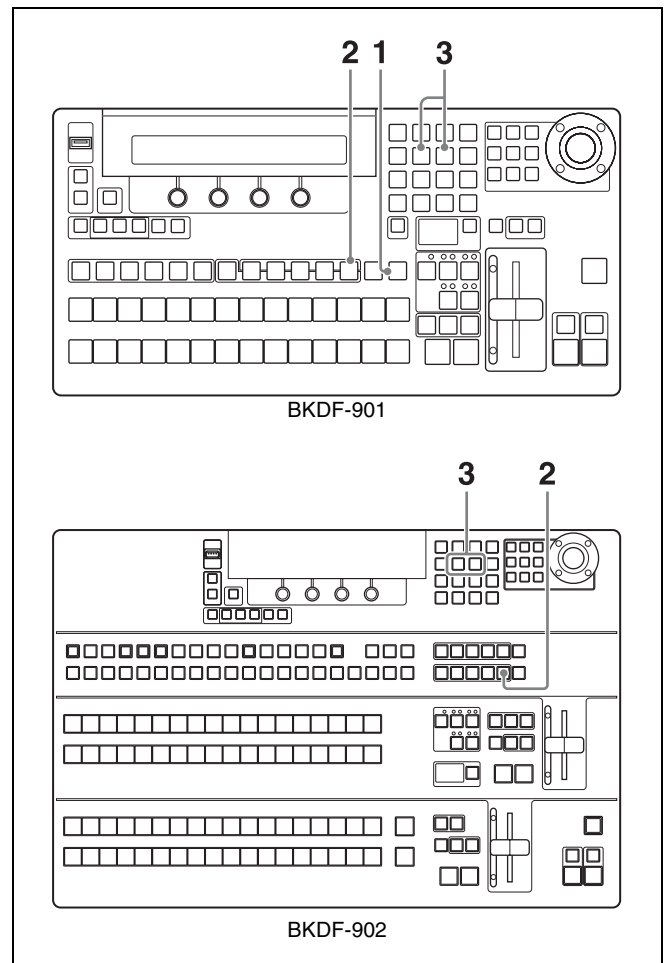

- 1** When using the BKDF-901: If the SHIFT button of the DME/SETUP block is not lit, press it to light it.
When using the BKDF-902: Skip to step 2.
- 2** Press the STATUS button.
The most recently used sub menu appears in the display panel.
- 3** Press the ◀ and ▶ buttons in the numeric keypad until the desired sub menu appears.

Option Board Information

The Board In/Out/Op1/Op2 sub menus allows you to check whether option boards are installed.

Knob	Parameter	Description	Settings
F1		Displays information about the board(s) in input expansion slots.	s: 4SDI Input Board a: SD analog input board d: DVI input board -: Not installed
F2		Displays information about the board(s) in output expansion slots.	s: 4SDI Output Board a: SD analog output board d: DVI output board -: Not installed
F3		Displays information about the board(s) in the DME1 and DME2 sockets.	dme: 2CH DME Board -: Not installed
F4		Displays information about the board(s) in the MV1 and MV2 sockets.	mv: Multi Viewer Board -: Not installed

Knob	Parameter	Description	Settings
F2	PS	Displays the alarm status of the power supply unit(s) in the processor unit.	ok: Operation is normal. ng: An error has been detected.
F3	FN	Displays the alarm status of the fan.	ok: Operation is normal. ng: An error has been detected.
F4	CP	Displays information about the installed power supply unit(s) in the control panel.	ok: Operation is normal. ng: An error has been detected.

Software Version Information

The Firmware sub menu allows you to check software version information.

The software name and version information appear in the display areas of the F1 to F4 knobs.

Alarms

The Alarm sub menu allows you to check the various alarms.

Knob	Parameter	Description	Settings
F1	PWR	Displays information about the installed power supply unit(s) in the processor unit.	Single A: Only one standard power supply unit is installed. Single B: Only one optional power supply unit is installed. Dual: Both a standard and an optional power supply unit are installed.

Overview

When you put the switcher into 3D mode, you can switch 3D video and add keys.

- In 3D mode, signals for the left eye and the right eye (referred to here simply as left and right signals) are handled as pairs.
- The available keys are KEY1, KEY2, DSK1, and DSK2. However, note that an operation is performed on only DSK1 and DSK2, that the DSK1 operation and DSK2 operation are linked to KEY1 and KEY2, respectively, and that DME effects cannot be applied to keys and chroma keys.

The following table lists the signals that you can use in 3D mode.

Signal type	Use in 3D mode
Signals input to SDI IN connectors 1 to 24	For 3D, separate signals are used for left and right.
Internal black signals	For applications other than 3D (titles and so on), the same signals are used for left and right.
Internal color matte signals	
Images stored in still image memory (STL1 to STL4)	You can choose either of the following. 2D mode: Use the same images for left and right. 3D mode: Use separate image for left and right.

I/O of 3D Mode Signals

Input example

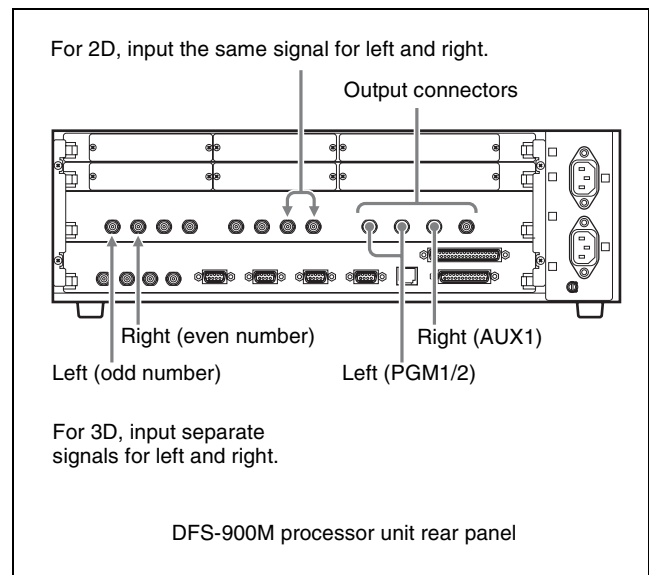

3D signal input destinations

Input left signals to odd numbered connectors and right signals to even numbered connectors.

2D signal input destinations

For titles and so on, input the same signal for left and right.

Signal output and connection destinations

Left signals are output from PGM Out, and right signals are output from AUX1.

You can view 3D video by connecting these outputs to L and R input connectors of a 3D monitor.

3D Mode Signal Assignments

Signals that are selectable with the cross-point selection buttons can be assigned for use in 3D mode. The following tables list the signal assignments available when you have changed the 3D System Mode setting from the factory default setting to on.

For information about how to change signal assignments, see “Assigning video input signals to cross-point selection buttons” (page 76).

When using the BKDF-901

(In the following table, “IN1” refers to the input signal connected to the SDI IN 1 connector.)

Cross-point buttons	Video signals		Video signal (specified with SHIFT button)	
	Left	Right	Left	Right
1	IN 1	IN 2	IN 17	IN 18
2	IN 3	IN 4	IN 19	IN 20
3	IN 5	IN 6	IN 21	IN 22
4	IN 7	IN 8	IN 23	IN 24
5	IN 9	IN 10	Black signal	Black signal
6	IN 11	IN 12	Black signal	Black signal
7	IN 13	IN 14	Black signal	Black signal
8	IN 15	IN 16	Black signal	Black signal
9	STL1 ^{a)}	STL1 ^{a)}	Color matte signal 1	Color matte signal 1
10	STL2 ^{a)}	STL2 ^{a)}	Color matte signal 2	Color matte signal 2
11	STL3 ^{a)}	STL3 ^{a)}	Color matte signal 3	Color matte signal 3
12	STL4 ^{a)}	STL4 ^{a)}	Color matte signal 4	Color matte signal 4

a) When using still images in 3D mode, assign separate images to left and right.

When using the BKDF-902

(In the following table, “IN1” refers to the input signal connected to the SDI IN 1 connector.)

Cross-point buttons	Video signals		Video signal (specified with SHIFT button)	
	Left	Right	Left	Right
1	IN 1	IN 2	Black signal	Black signal
2	IN 3	IN 4	Black signal	Black signal
3	IN 5	IN 6	Black signal	Black signal
4	IN 7	IN 8	Black signal	Black signal
5	IN 9	IN 10	Black signal	Black signal

Cross-point buttons	Video signals		Video signal (specified with SHIFT button)	
	Left	Right	Left	Right
6	IN 11	IN 12	Black signal	Black signal
7	IN 13	IN 14	Black signal	Black signal
8	IN 15	IN 16	Black signal	Black signal
9	IN 17	IN 18	Black signal	Black signal
10	IN 19	IN 20	Black signal	Black signal
11	IN 21	IN 22	Black signal	Black signal
12	IN 23	IN 24	Black signal	Black signal
13	STL1 ^{a)}	STL1 ^{a)}	Color matte signal 1	Color matte signal 1
14	STL2 ^{a)}	STL2 ^{a)}	Color matte signal 2	Color matte signal 2
15	STL3 ^{a)}	STL3 ^{a)}	Color matte signal 3	Color matte signal 3
16	STL4 ^{a)}	STL4 ^{a)}	Color matte signal 4	Color matte signal 4

a) When using still images in 3D mode, assign separate images to left and right.

System Settings

- 1** When using the **BKDF-901**: If the SHIFT button in the DME/SETUP block is not lit, press it to light it.
When using the **BKDF-902**: Skip to step 2.
- 2** Press the SYSTEM button.

The most recently used sub menu appears in the display panel.
- 3** Press the < or > button in the numeric keypad until the 3D SYSTEM sub menu appears.

Switching to 3D Mode

Set the following parameters with knob 1.

Knob	Parameter	Description	Settings
F1	3D Mode	Operate in 3D mode	On, Off

Selecting the 2D/3D Mode of Stored Still Images

When the switcher is operating in 3D mode, you can use images stored in still image memory in either 2D or 3D mode.

Select the mode by setting the following parameters with knobs 2 and 3.

Knob	Parameter	Description	Settings
F2	3D Still1 & Still2	Still1 image mode	2D, 3D
F3	3D Still3 & Still4	Still2 image mode	2D, 3D

When you select 2D, the same signal is used for left and right.

When you select 3D, separate signals are used for left and right.

Signal Assignments for Using Still Images in 3D Mode

When you set the still image mode to 3D, the signal assignments of the cross-point buttons (see the table shown on the previous page) are changed.

When using the BKDF-901

When you select 3D with the F2 knob or F3 knob, the signal assignments of cross-point buttons 9 and 10 or 11 and 12 are changed as follows.

Cross-point buttons	Video signals	
	Left	Right
9	STL1	STL2
10	STL2	STL1
11	STL3	STL4
12	STL4	STL3

When using the BKDF-902

When you select 3D with the F2 knob or F3 knob, the signal assignments of cross-point buttons 13 and 14 or 15 and 16 are changed as follows.

Cross-point buttons	Video signals	
	Left	Right
13	STL1	STL2
14	STL2	STL1
15	STL3	STL4
16	STL4	STL3

3D Mode Operations

The following limitations apply to operations in 3D mode.

- The available transition types are limited to cut and mix by button operations.
- When an operation on a DSK is performed, M/E keys behave in the same way.
You cannot directly operate M/E keys.
The DSK1 and DSK2 values set in the menu are applied to KEY1 and KEY2, respectively.
- Events created in 3D mode can be used only in 3D mode.
- Sequence functions are not available.
- A function which captures still images from input signals is available only for the left signals.

When using the BKDF-901

Some buttons are not available (the buttons shown in black in the following figure).

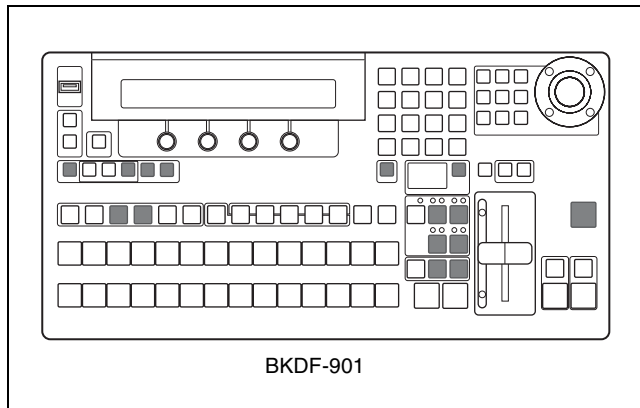

Operating block	Unavailable buttons
KEYER block	DME ENBL, CK, MASK EDGE SHADOW (EXT and SELF are disabled for KEY1 and KEY2.)
KEY DELEGATION block	KEY3, KEY4
Transition block	TRANS PVW, KEY1 to KEY4 WIPE (FAM), DME (NAM) PRIORITY, FTB

When using the BKDF-902

Instead of operating with the M/E Cross-Point Bus block and the M/E Transition block, use the PROGRAM/PRESET Cross-Point Bus block and the PROGRAM/PRESET Transition block.

Some buttons are not available (the buttons shown in black in the following figure).

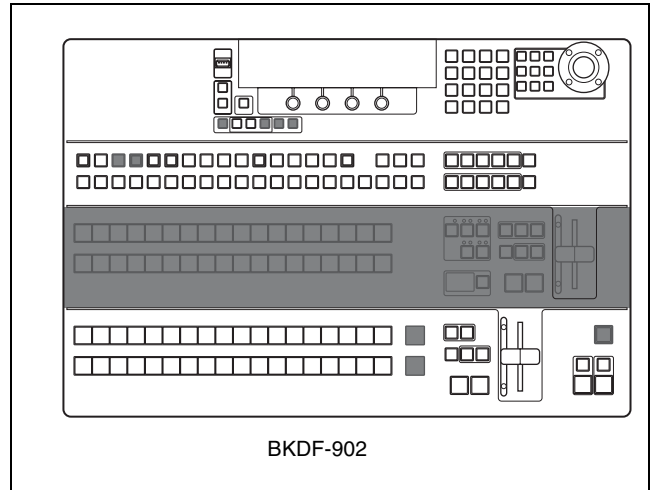

Operating block	Unavailable buttons
KEYER block	DME ENBL, CK, MASK EDGE SHADOW (EXT and SELF are disabled for KEY1 and KEY2.)
KEY DELEGATION block	KEY3, KEY4
M/E rows	All buttons and the fader lever
PROGRAM/PRESET Cross-Point Bus block	M/E buttons
KEY DELEGATION block	KEY3, KEY4
DSK/Fade to Black Control block	FTB

Appendix

Menu Structure

The following menu tree shows the configuration of the switcher's menu system and lists the menu items that appear in the display panel. Names in parentheses are the names that appear in GUI menu screens, which are displayed when you connect an optional PC monitor or an optional touch panel monitor.

For more information about GUI menu screens, see "Menu Operations in the GUI Menus" (page 64).

Transition Menu (for Transition, Wipe, and DME Settings)

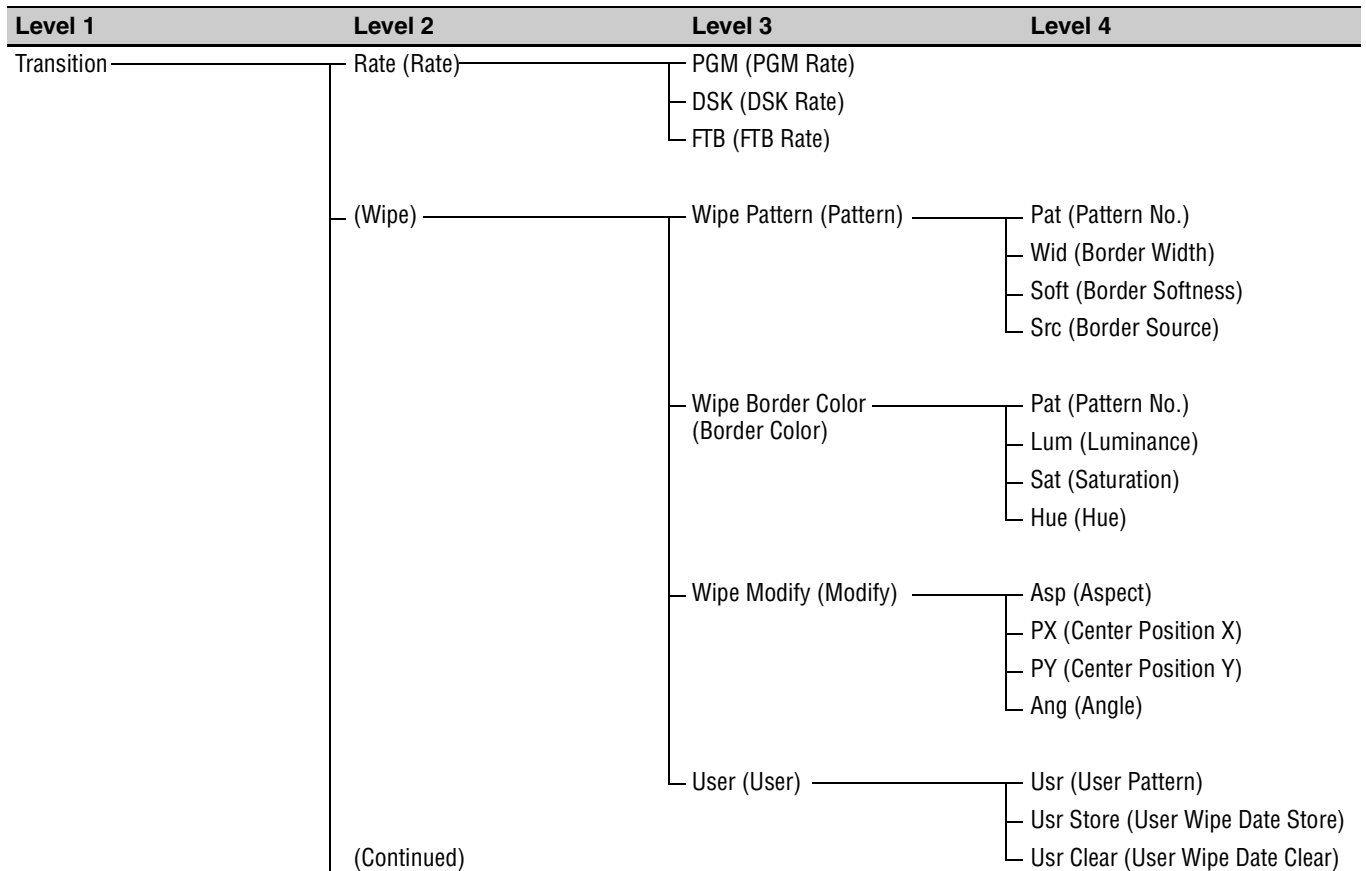

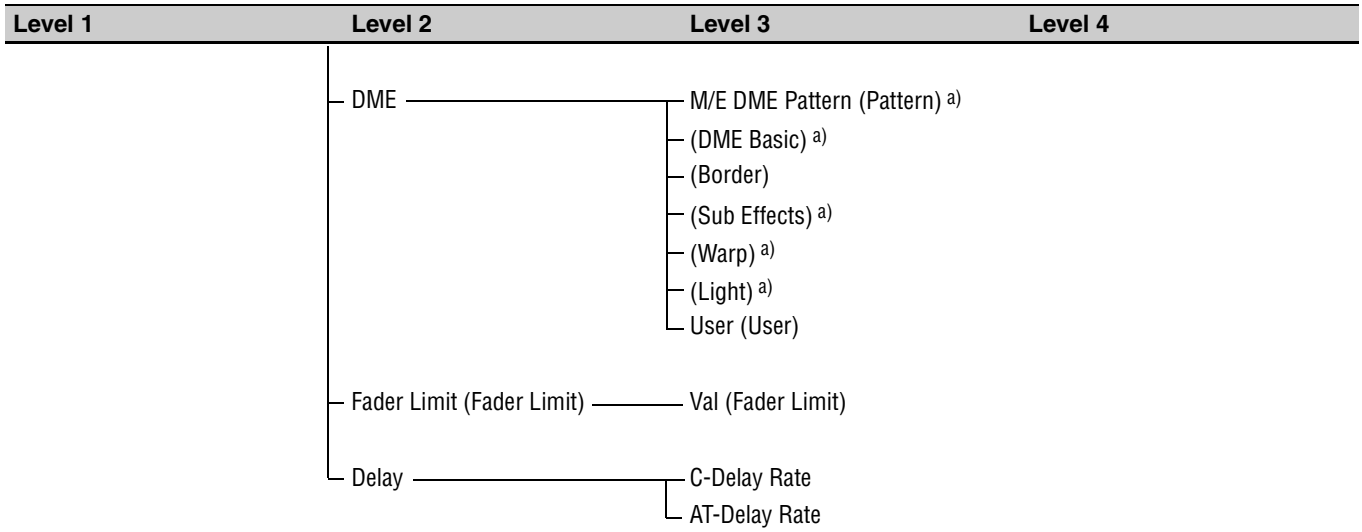

a) For details, see “DME Menu (for DME Settings)” (page 183).

Keyer Menu (for Key Settings)

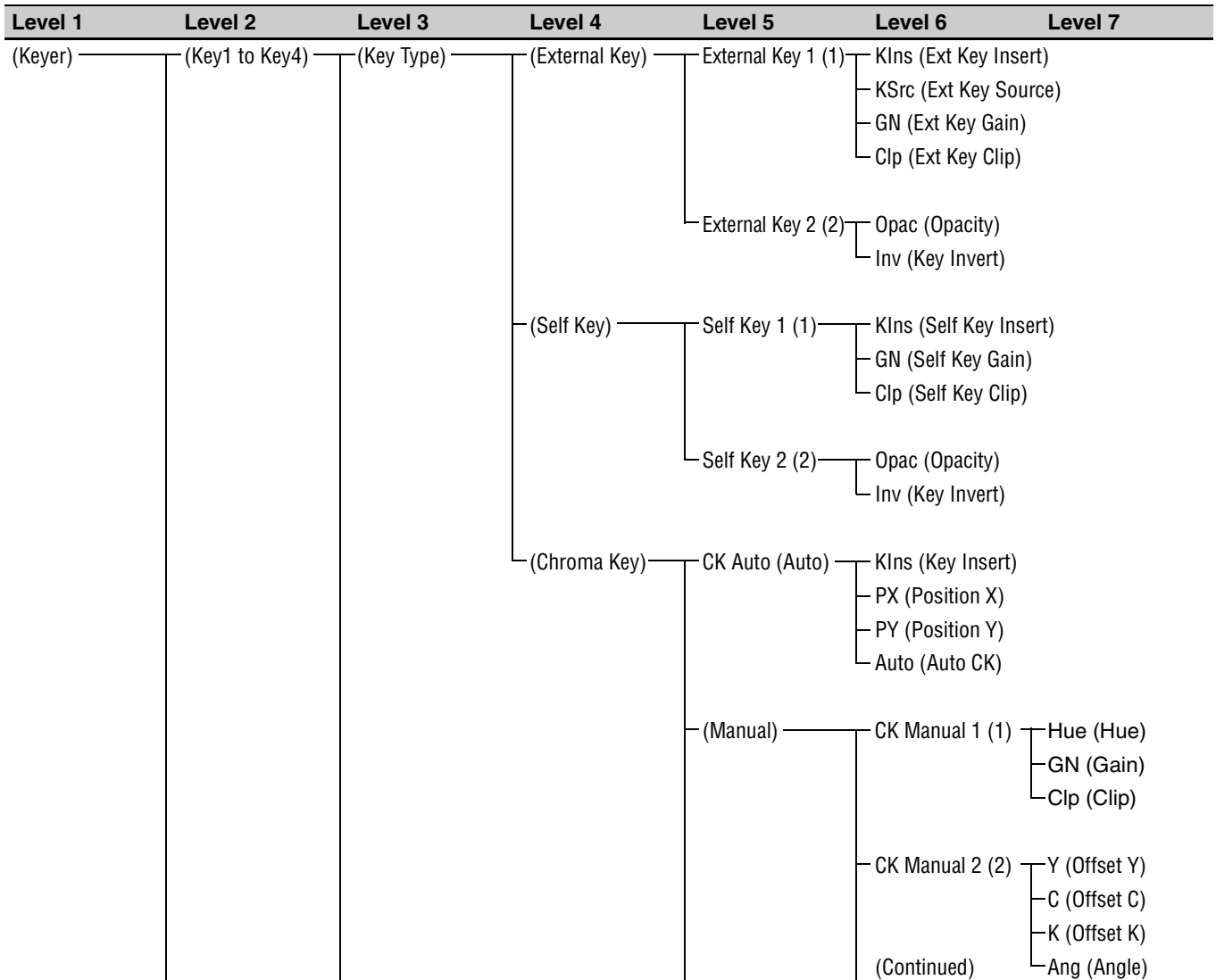

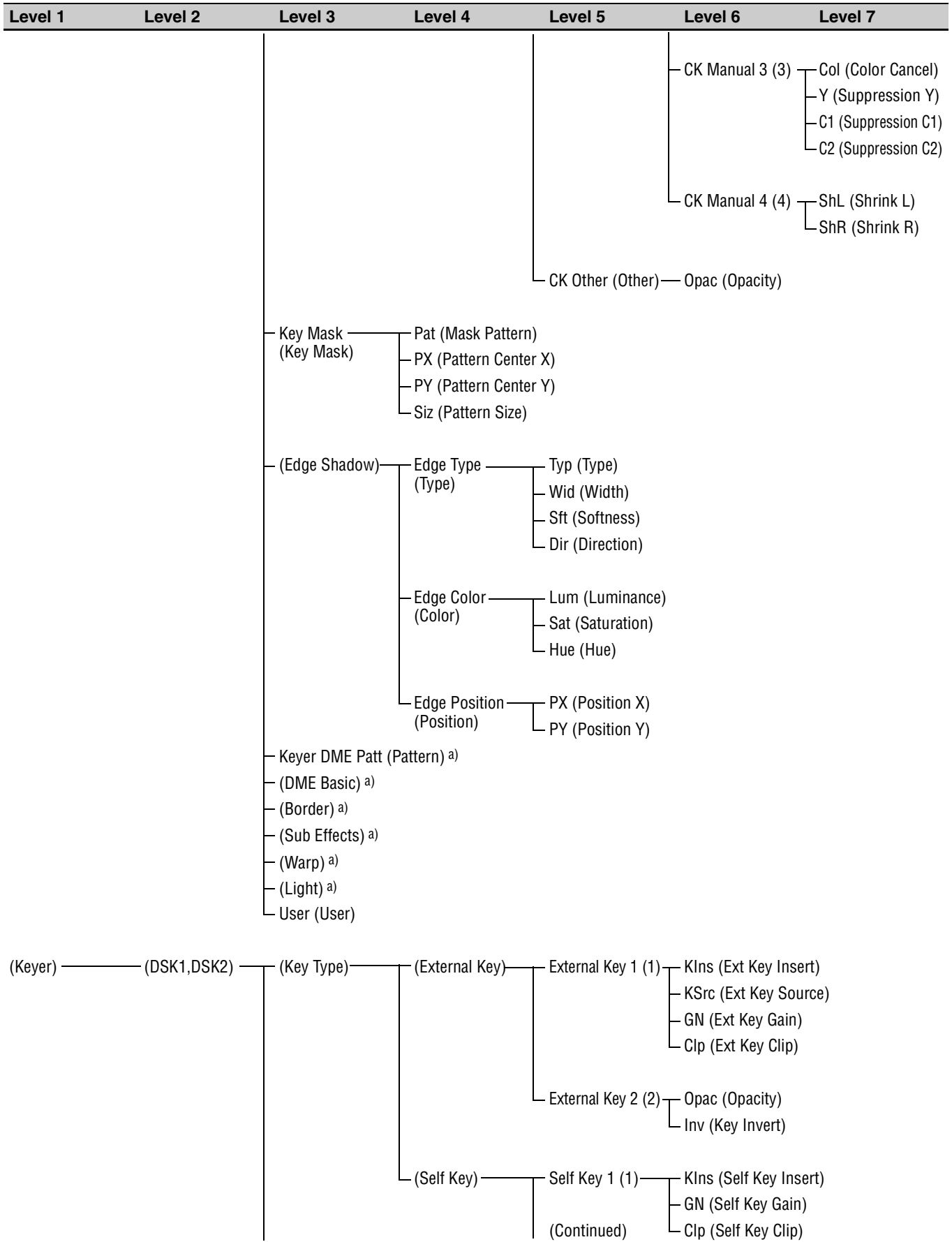

Appendix

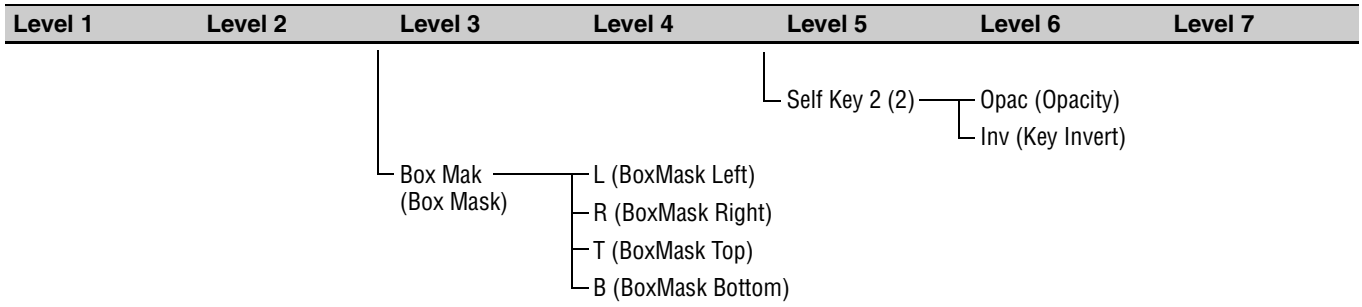

a) For details, see “DME Menu (for DME Settings)” (page 183).

Still Store Menu (for Still Image Settings)

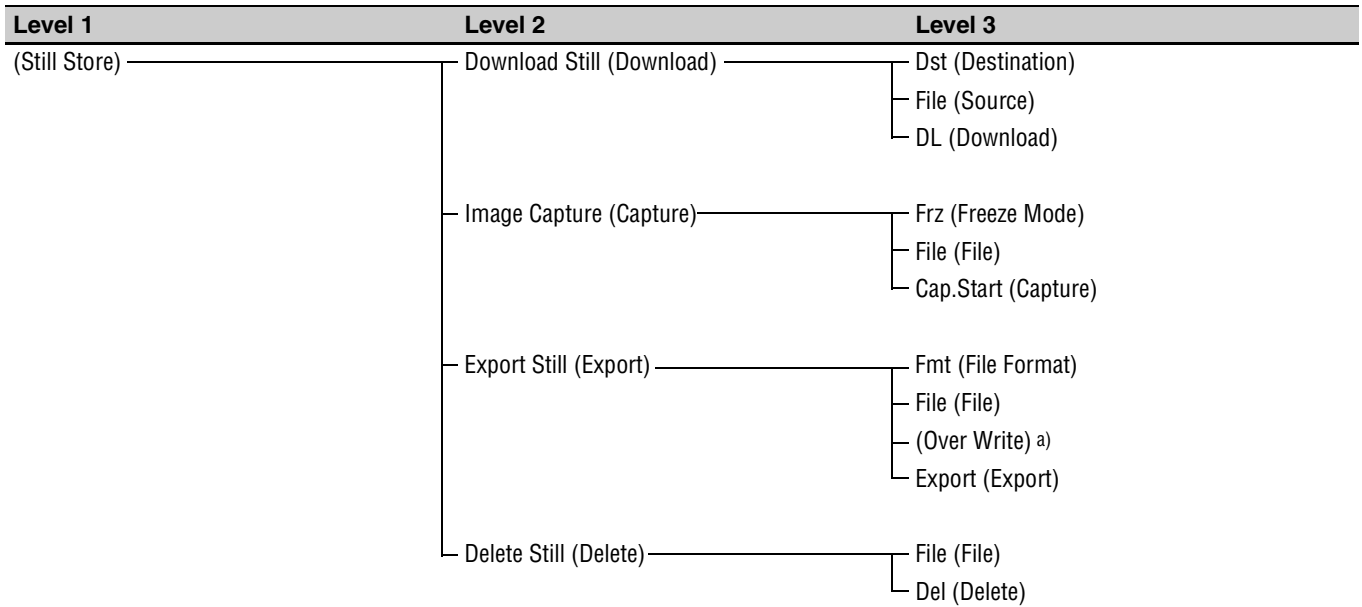

a) The selection items that appear in the display panel are OverWrite and NewFile.

Sequence Event Menu (for Sequence and Event Registration)

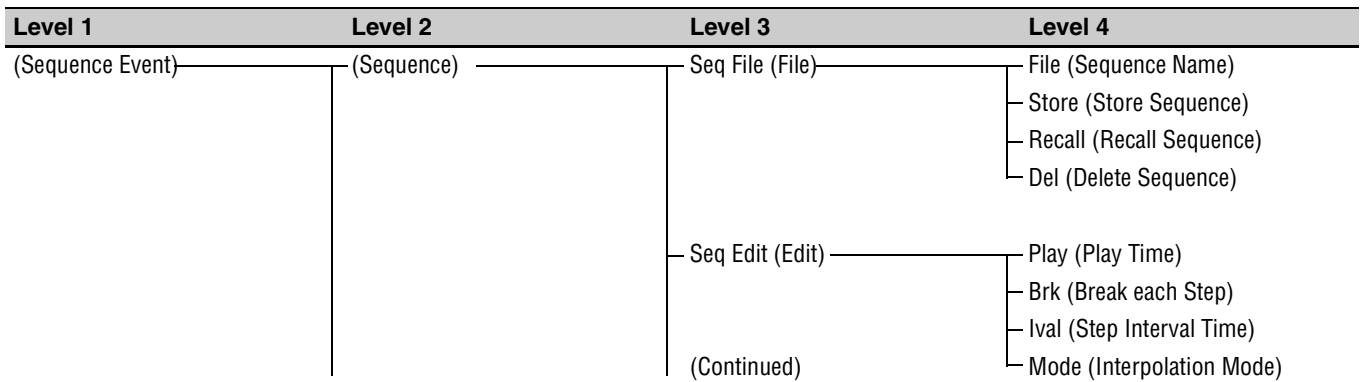

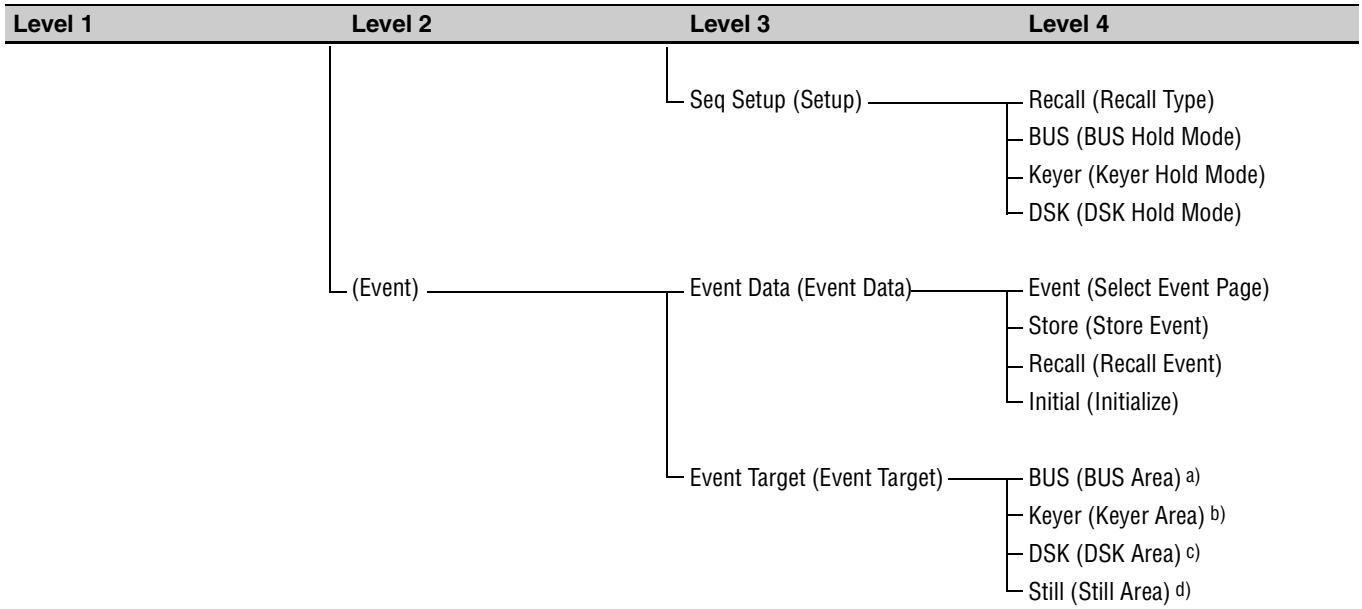

a) The selection items that appear in the display panel are BUS On, BUS Off, and P-P Hold.

b) The selection items that appear in the display panel are Keyer On and Keyer Off.

c) The selection items that appear in the display panel are DSK On and DSK Off.

d) The selection items that appear in the display panel are Still 1, Still 2, Still 3, Still 4, Still On and Still Off.

Setup Menu (for System Settings)

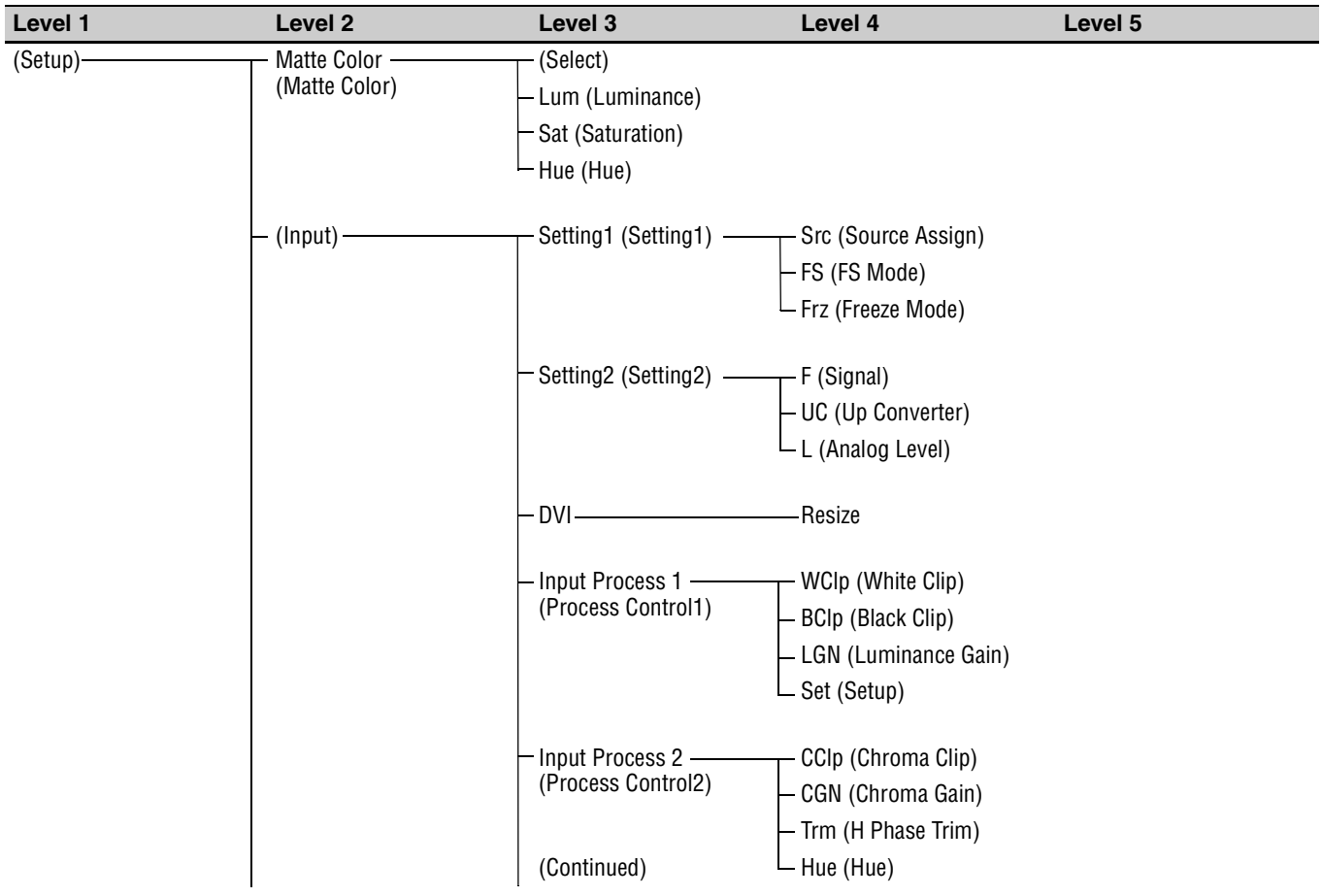

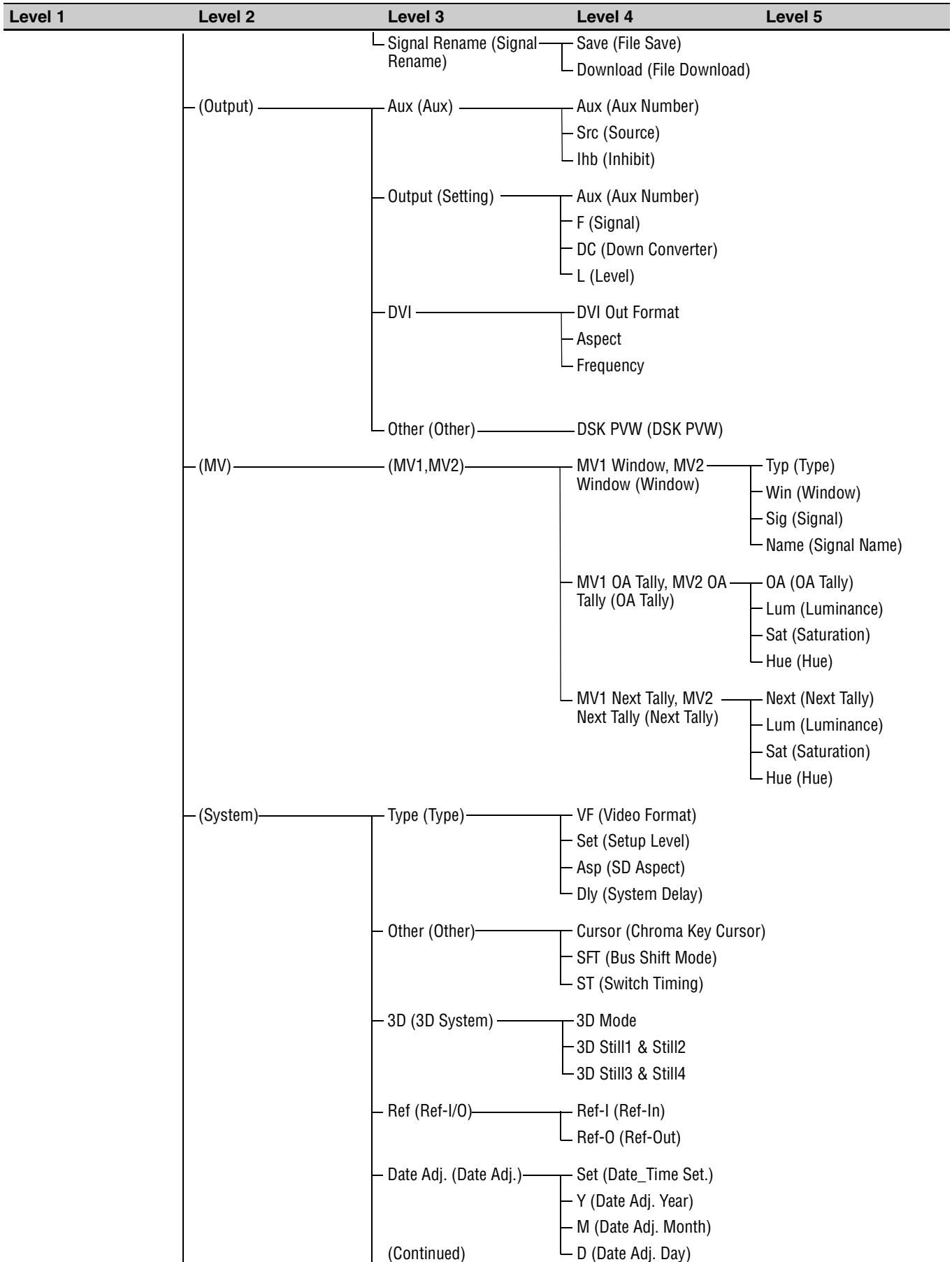

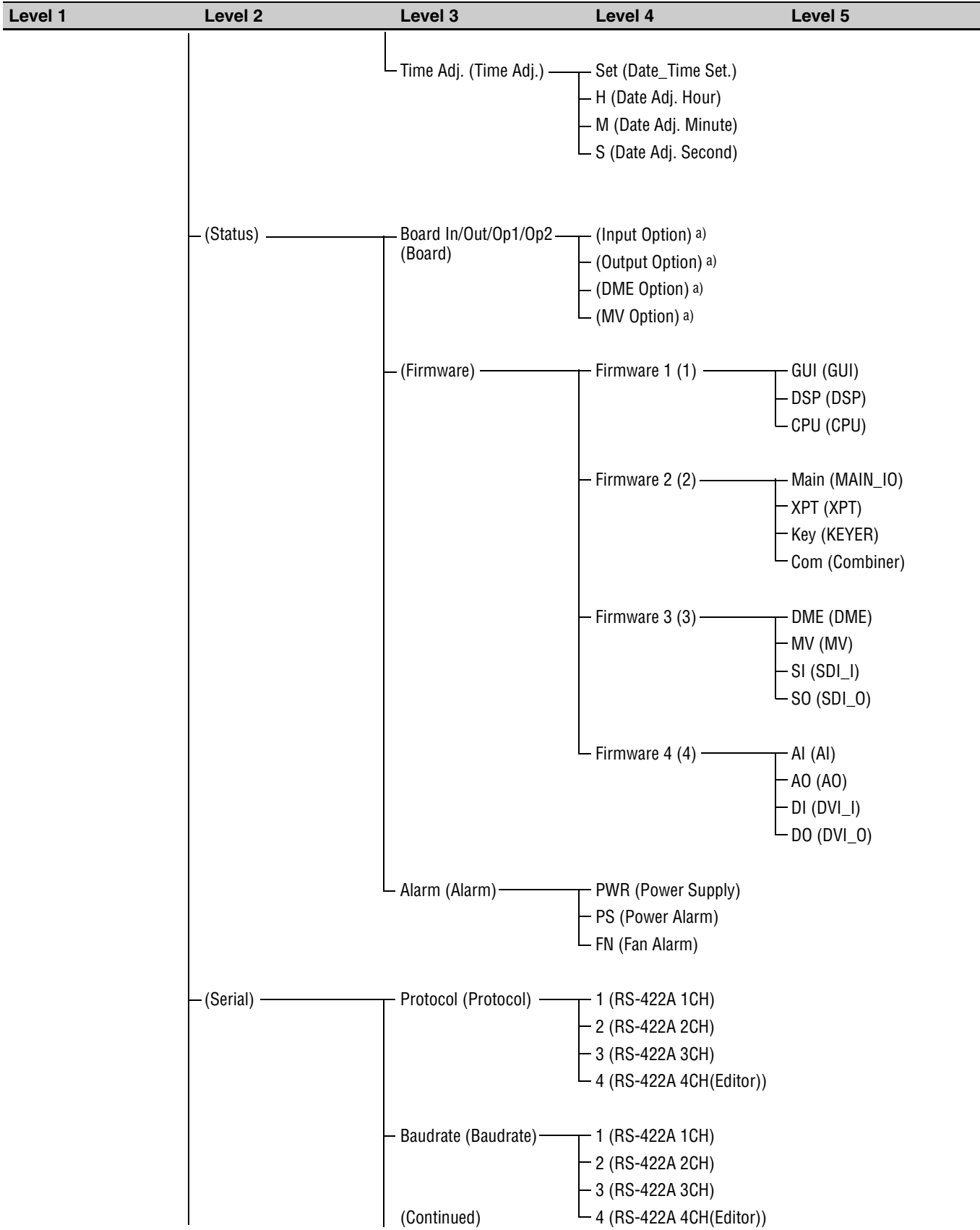

Appendix

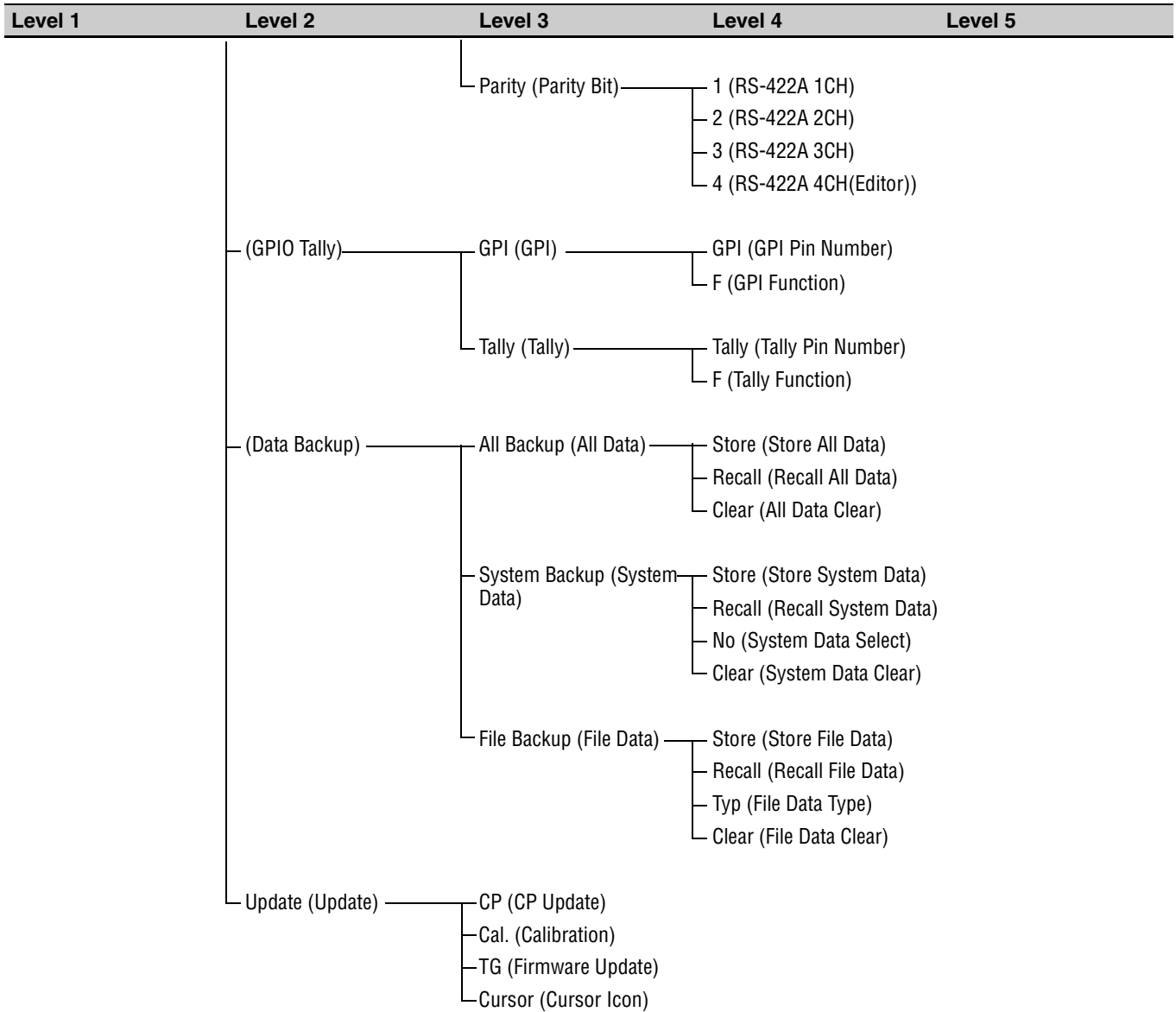

a) The slot numbers of installed boards appear in the display panel.

DME Menu (for DME Settings)

This is a list of items related to DME settings that appear in the Transition menu and the Keyer menu. In the Transition menu, the “xxx” in the list is replaced by “M/E DME”. In the Keyer menu, “xxx” is replaced by “Keyer”.

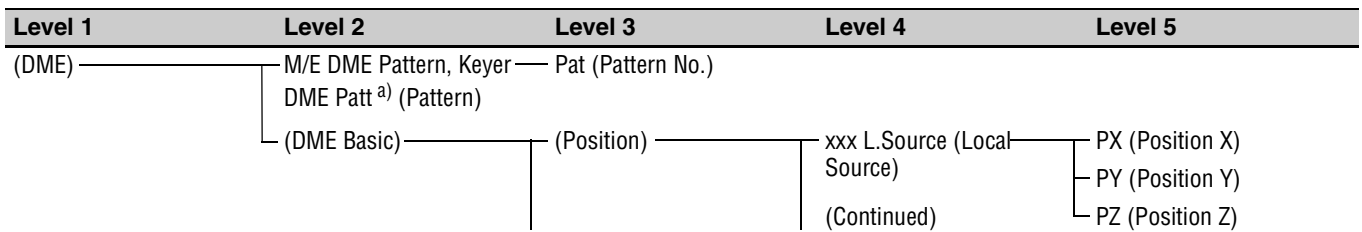

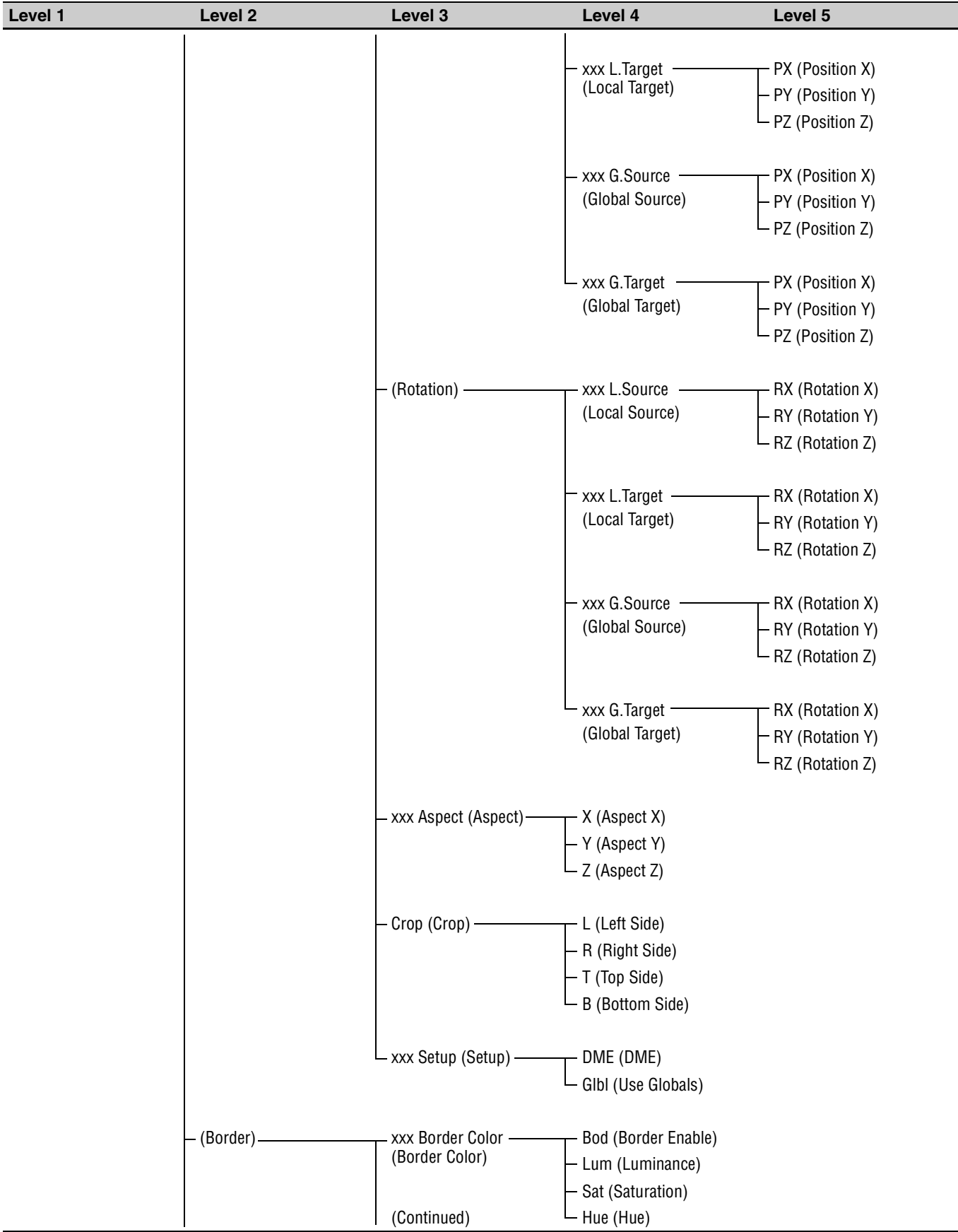

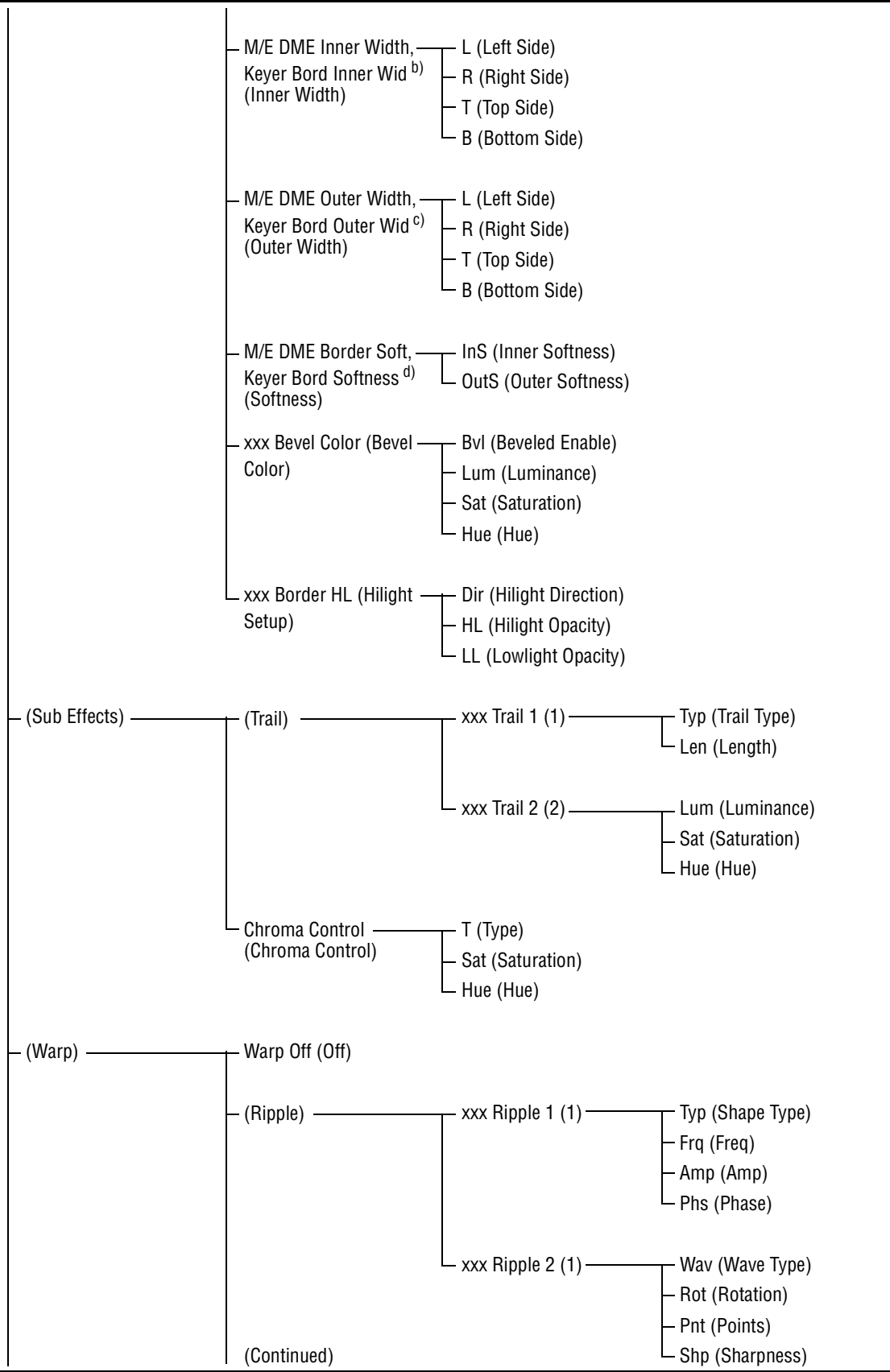

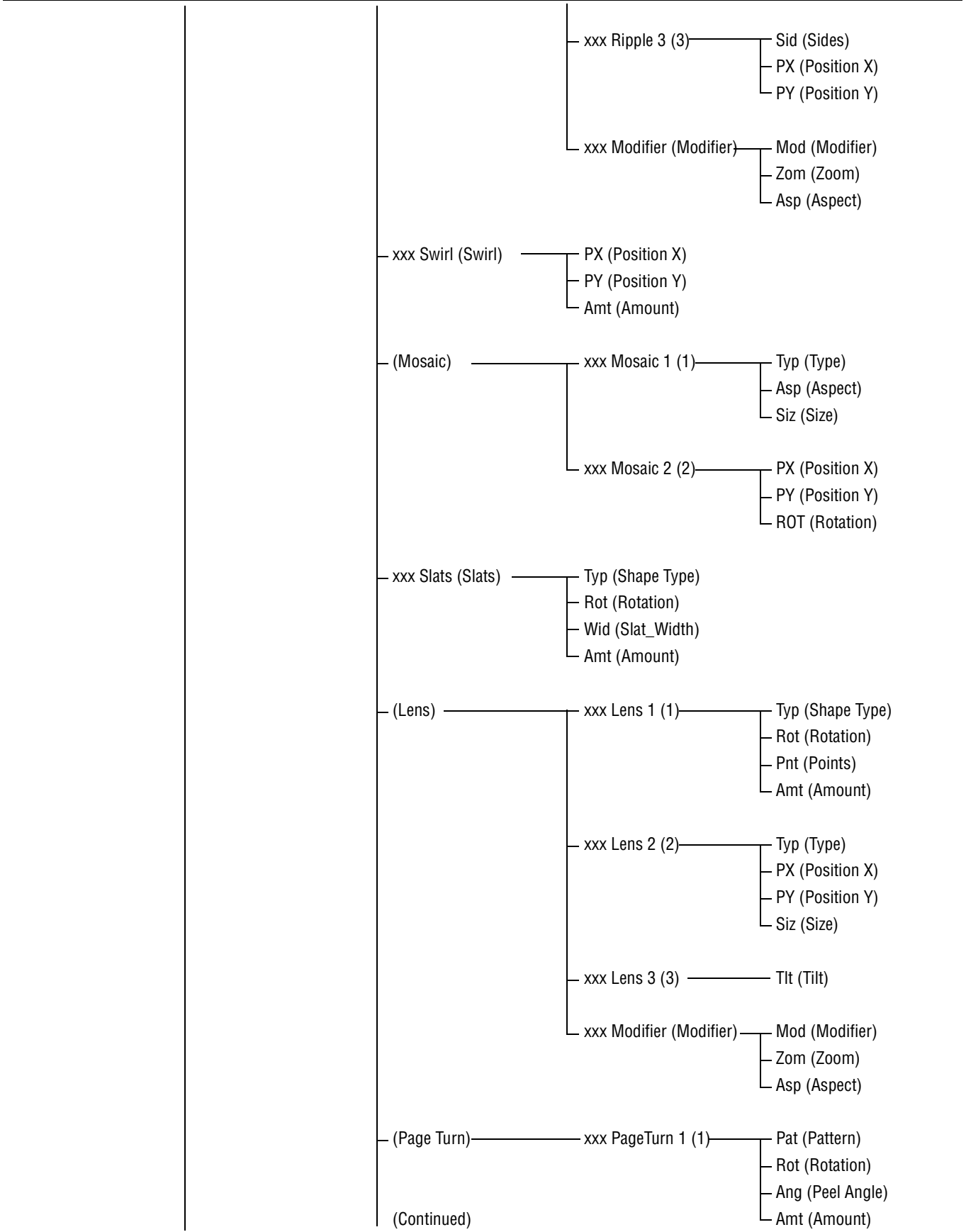

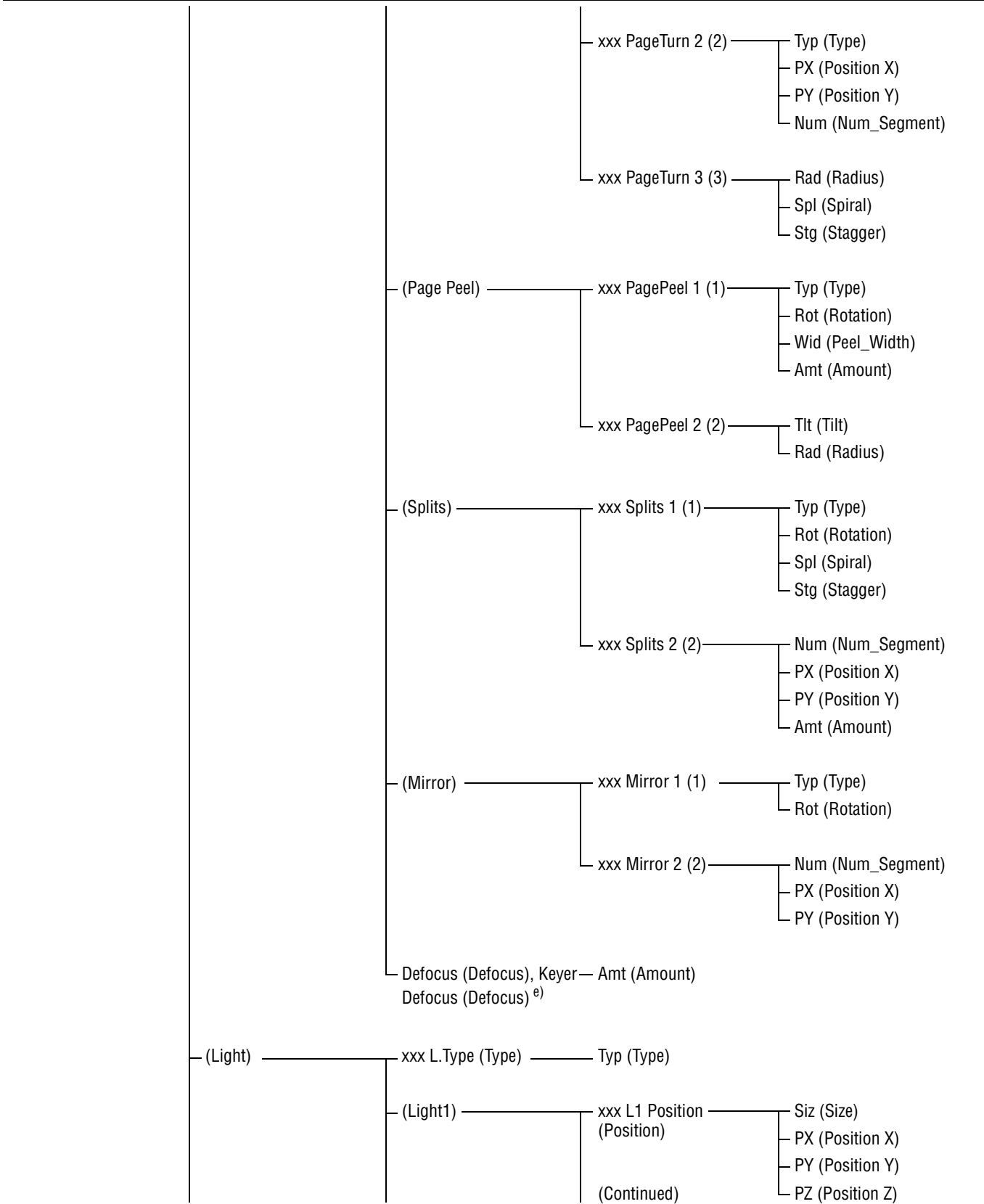

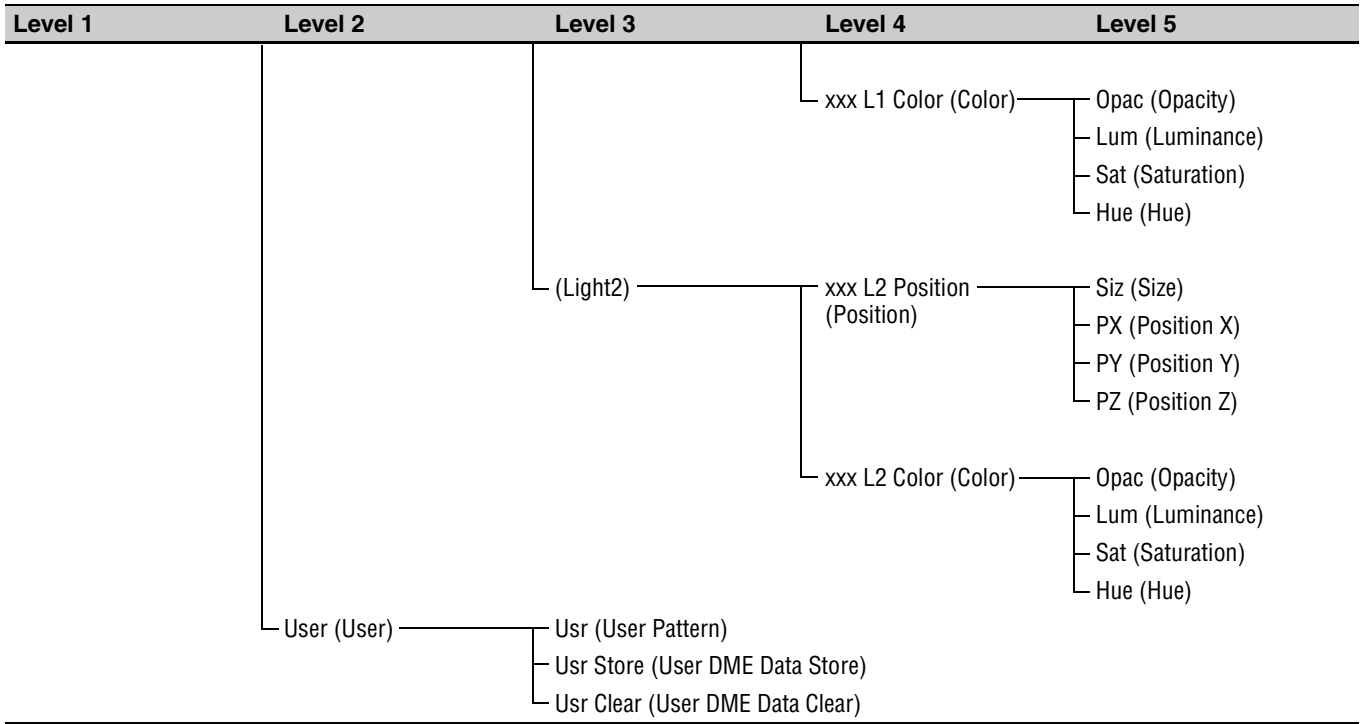

































- a) M/E DME Pattern in the Transition menu, and Keyer DME Patt in the Keyer menu
- b) M/E DME Inner Width in the Transition menu, and Keyer Bord Inner Wid in the Keyer menu
- c) M/E DME Outer Width in the Transition menu, and Keyer Bord Outer Wid in the Keyer menu
- d) M/E DME Border Soft in the Transition menu, and Keyer Bord Softness in the Keyer menu
- e) Defocus in the Transition menu, and Keyer Defocus in the Keyer menu

Pattern List



Wipe

Basic wipe

000		001		002		003		004	
005		006		007		008		009	
010		011		012		013		014	
015		016		017		018		019	
020		021		022		023		024	
025		026		027		028		029	
030		031		032		033		034	
035		036		037		038		039	
040		042		043		044		045	
046		047		048		065		066	
067		068		069		070		071	
072		073		074		075		076	
077		078		079		080		081	

082		083		084		085		086	
087		088		089		090		091	
092		093		094		095		096	
097		098		099		100		101	
102		103		104		105		106	
107		108		109		110		111	
112		113		114					

User wipe

120		159	
-----	---	-----	-----	-----	---

Mask

000		001		002		003		004	
005		006		007		008		009	
010		011		012		013		014	
015		016		017		018		019	
020		021		022		023		024	
025		026		027		028		029	
030		031		032		033		038	
039		040		042		043		044	
045		046		047		048		065	
066		067		068		069		075	
076		077		078		079		085	
086		087		088		089		090	
091		092		093		094		105	
106		107		108		109		110	
111		112		113		114			













DME Wipe

Note

When you specify the number of a DME wipe pattern from an editor, add 200 to the number of the pattern that you want to specify.

2D and basic 3D effects

000		001		002		003		004	
005		006		007		008		009	
010		011		012		013		014	
015		016		017		018		019	
020		021		022		023		024	
025		026		027		028		029	
030		031		032		033		034	
035		036		037		038		039	
040		041		042		043		044	
045		046		047		048		049	
050		051		052		053		054	
055		056		057		058		059	
060		061		062		063		064	

065		066		067		068		069	
070		071		072		073		074	
075		076		077					

3D DME effects

100		101		102		103		104	
105		106		107		108		109	
110		111		112		113		114	
115		116		117		118		119	
120		121		122		123		124	
125		126		127		128		129	
130		131		132		133		134	
135		136		137		138		139	
140		141		142		143		144	
145		146		147		148		149	
150		151		152		153		154	
155		156		157		158		159	
160		161		162		163		164	

165		166		167		168		169	
170		171		172		173		174	
175		176		177		178		179	
180		181		182		183		184	
185		186		187		188		189	
190		191		192		193		194	
195		196		197		198		199	
200		201		202		203		204	
205		206		207		208		209	
210		211		212		213		214	
215		216		217		218		219	
220		221		222		223		224	
225		226		227		228		229	

230		231		232		233		234			
235		236		237		238		239			
240		241		242		243		244		245	
245		246		247		248		249			
250		251		252							

User effects

300		339	
-----	--	-----	-----	-----	--

Messages and Actions to Take

Messages may appear in the display panel of the control panel during operation of the switcher.

First consult the following table to locate the message, and then take the indicated action. If the problem persists, contact a Sony service representative.

Message		Description	Action to take
Display panel	GUI menu screen		
Bad Image File		Appears when an attempt is made to load an unloadable still image file.	Select another still image file.
Bad Seq. File	Bad Sequence File	Appears when a stored sequence file cannot be loaded to recall a sequence.	Try loading the sequence file again.
Can't export Still	Can't export this Still file	Appears when the export of a still image file fails.	Try exporting the still image file again.
Can't load Still	Can't load Still File	Appears when a communications error occurs during the download of a still image file.	Try downloading the still image file again.

Message		Description	Action to take
Display panel	GUI menu screen		
Config Error (abbcc)		<p>Appears if an internal FPGA (Field-Programmable Gate Array) fails to start when the processor starts.</p> <p>abbcc: Five-digit hexadecimal error code</p> <p>a=1: CPU_FPGA error a=2: COMB_FPGA error a=3: I/O expansion board error, standard I/O board error or function expansion board error</p> <p>When a=1 or a=2, bb and cc are 0. When a = 3, the values of bb (bit0 to bit5) and of cc (bit0 to bit7) show where the error occurred.</p> <p>bit: 1 for the FPGA which failed in activation, and 0 for the FPGA which is normally activated.</p> <p>The relation between bits and error locations are as follows.</p> <p>bit0: Left board on lower installation tray bit1: Center board on lower installation tray bit2: Left board on upper installation tray bit3: Center board on upper installation tray bit4: Right board on lower installation tray bit5: Right board on upper installation tray</p> <p>cc: Standard I/O board/function expansion board error</p> <p>bit0: Standard I/O board (MAIN_IO) bit1: Standard I/O board (XPT) bit2: Standard I/O board (KEYER) bit3: Standard I/O board (DME) bit4: Function expansion board in DME1 socket bit5: Function expansion board in DME2 socket bit6: Function expansion board in MV1 socket bit7: Function expansion board in MV2 socket</p>	<p>Power the processor off and then power it on again. If the error persists, reprogram the FPGA. If the error still persists, the board may need to be replaced.</p> <p>Note FPGAs start in the following order (③ and ④ at the same time). ① CPU_FPGA ② COMB_FPGA ③ I/O expansion board FPGAs ④ Standard I/O board and function expansion board FPGAs If an error occurs at ①, the error is detected only for ① because ② to ④ are not activated. In the same way, if an error occurs at ②, the error is detected only for ② because ③ and ④ are not activated. Therefore, another error may occur when the system starts again, even after correcting a detected error.</p>
DME assign failure		Appears when the DME option installation status has changed after shutting down the switcher, and the previous number of DME channels cannot be restored after the switcher starts.	Check the current DME option installation status.
DME assign too much	DME assign too much. Reduce!	Appears when an attempt is made to use a new DME channel, even though the maximum number of DME channels are already in use.	Reduce the number of DME channels and try the operation again.
DME No. reserved		Appears when no DME effect is registered for the selected number.	Select another DME effect.

Message		Description	Action to take
Display panel	GUI menu screen		
File read error		Appears in the following cases. a) Loading of the file failed during a still image file download. b) Loading of the signal name data failed when display of multi-view signal names is on.	a) Try downloading the still image file again. b) Reset the settings of the output video, and try turning the display of signal names off and on again.
Gray scale loaded	Gray scale file loaded	Appears when an 8-bit gray scale still image file is loaded.	Select a still image file in another format.
Include Wrong DME No		Appears when you attempt to recall a user pattern, sequence, or event that uses an effect not supported by this version. Backgrounds and keys 1 to 4 are not recalled if they include effects not supported by this version.	Save the user pattern, sequence, or event after modifying it to use only supported effects, and then recall it again.
No assignable DME		Appears when an attempt is made to change a transition type from a non-DME effect to a DME effect, even though the maximum number of DME channels are already in use.	Reduce the number of DME channels and try the operation again.
No free memory		Appears when the control panel OS has no free memory.	Wait for a while and try the operation again.
No KeyFrame		Appears when an attempt is made to delete the current keyframe from a sequence when the target keyframe does not exist.	Select another keyframe.
No more KeyFrames	No more KeyFrames available	Appears when an attempt is made to register a new keyframe when the maximum number of keyframes has already been registered in a sequence, or when an attempt is made to change the current keyframe to higher than the maximum number of registered keyframes.	Delete one or more keyframes and try again.
No Option		Appears when you switch to the MV1 or MV2 sub menu with no BKDF-950 installed.	Install a BKDF-950.
No specified SEQ	No specified SEQ file	Appears when the specified sequence file cannot be found.	Specify another sequence file.
No specified Still	No specified Still file	Appears when the specified still image file cannot be found.	Select another still image file.
No system-data file		Appears when system data file cannot be found.	Select the system data and try the operation again.
No update file	No specified update file	Appears when the specified update file cannot be found.	Check to make sure that the specified update file exists on a USB flash drive connected to the USB MEMORY connector, and then try the operation again.
No USB Device USB		Appears when no USB flash drive is connected.	Connect a USB flash drive.
No User Pattern		Appears when you recall an event that uses a wipe or DME user pattern if the user pattern is not registered. Recall an unregistered user pattern by specifying 0 as pattern number.	Register the user pattern used by the event and then recall the event again.

Message		Description	Action to take
Display panel	GUI menu screen		
No.41 reserved	Wipe 41 reserved	Appears when you select wipe pattern number 41.	Wipe pattern 41 cannot be selected. Select another pattern.
Not enough in USB	Not enough space in USB memory	Appears when the USB flash drive is not properly connected or there is not enough free memory in a USB flash drive.	Reconnect the USB flash drive or exchange the USB flash drive for another one with enough free memory.
Operation Prohibited		Appears when you select a sub menu of the System menu during execution of a sequence.	Wait for execution of the sequence to end and then select the sub menu again.
Patt. not available	Pattern not available	Appears when you select a pattern that is not available.	Select another pattern.
Picture too large		Appears when an attempt is made to load a still image file that is too large to be handled by the switcher.	Select a still image file in another format.
Power/Fan Alarm !!		Appears when a power supply or fan error is detected.	Check the location of the error (which power supply, which fan) in the Setup >Status >Alarm menu (see page 171) and contact a Sony service representative. A part may need to be replaced.
Read Only File Exist	There is Read Only File	Appears when an attempt is made to do one of the following operations on a read-only still image file on a USB flash drive. <ul style="list-style-type: none"> • Overwrite the still image file by executing Recall All Data, Recall File Data, or Still Export • Delete the still image file by executing Still Delete or File Data Clear 	Move the read-only file on the USB flash drive to another folder, or enable overwriting or deletion of the file by removing the delete, rename, or read only check mark.
Recover broken file		Appears under the following conditions when you recall a file, if the setting values of the loaded data are abnormal because the file is broken or for some other reason. <ul style="list-style-type: none"> • Reading system data when starting a control panel • Executing Recall All Data or Recall System Data to recall system data from a USB flash drive When this error occurs, parameters with abnormal setting values are reset to initial values.	If this error occurs when the system is starting, restart the system. If this error occurs when recalling a file from a USB flash drive, recall the system data again.
SEQ not specified	SEQ file not specified	Appears when no sequence file is specified.	Specify a sequence file.
SEQ ope. prohibited	SEQ operation prohibited	Appears in the following cases. <ol style="list-style-type: none"> When an attempt is made to enter edit mode without creating or recalling a sequence. When an attempt is made to change the current keyframe, for example by using the numeric keypad ◀ or ▶ buttons, when a sequence is playing or paused. 	<ol style="list-style-type: none"> Create or recall a sequence. Wait until play of the sequence finishes and then try again.

Message		Description	Action to take
Display panel	GUI menu screen		
Signal Name Failure		Appears when the display of signal names is enabled for multi-view output, and the signal name display data cannot be sent.	Reset the settings of the output video, and try turning the display of signal names off and on again
Status was modified	Status was because boards were different modified	<p>Appears when data is recalled under the following conditions, if the sources specified for parameters cannot be selected because the configuration of currently installed option boards differs from the board configuration at the time when the data was saved.</p> <ul style="list-style-type: none"> • Reading system data when starting a control panel • Executing Recall All Data or Recall System Data to recall system data from a USB flash drive • Recalling a sequence • Recalling an event <p>When this error occurs, parameters that specify sources which cannot be selected are set to BLK.</p>	Install option boards in the same configuration as when the data was saved, and then execute the recall again.
Update Failure		Appears when an update fails.	Try executing the update again.
Wipe No. reserved		Appears when no wipe pattern is registered for the selected number.	Select another pattern.

Updating the Software

The following method is used to update the software of the DFS-900M.

Checking the Software Versions

Before updating the DFS-900M software, check the current software versions to determine whether to need software update.

- 1 Turn on the POWER switch on the processor unit (DFS-900M) and on the control panel (BKDF-901/902).
- 2 When using the BKDF-901: If the SHIFT button in the DME/SETUP block is not lit, press it to light it.
- 3 Press the STATUS button.

The most recently used sub menu appears in the display panel.

- 4 Press the ◀ and ▶ buttons in the numeric keypad until the Firmware1 sub menu appears.
- 5 Check the version numbers in the second line.

```
Firmware1
GUI= 1.50          DSP= 1.21 CPU= 1.03
```

- 6 Press the ◀ and ▶ buttons in the numeric keypad until the Firmware2 sub menu appears.
- 7 Check the version numbers in the second line.

```
Firmware2
Main=1.01 XPT= 1.07 Key= 1.04 Com= 1.09
```

- 8 Press the ◀ and ▶ buttons in the numeric keypad until the Firmware3 sub menu appears.
- 9 Check the version numbers in the second line.

```
Firmware3
DME= 1.07 MV= 1.01 SI= 1.03 SO= 1.02
```

If you find any item requiring software update, perform the following operations to update the software.

Preparing for Software Update

Preparing equipment and the most recent versions of software

- Personal computer
- USB flash drive: Formatted with the FAT16 or FAT32 file system.

Note

- Only connector direct connection type is available.
- Do not use any other type that stores data converted from other media or uses a conversion adapter.
- Software: Download required software files from the specified site.

Preparing a USB flash drive for software update

Extract the downloaded software file into a directory and copy all the files in the directory to the root directory of a prepared USB flash drive.

Backing up all data

Be sure to back up all data (system data and file data) before updating the software because software updating will initialize the setting values.

- **System data:** Data such as events, I/O settings, initial values, and status data.
- **File data:** Still image file data stored in the control panel, user pattern data, and sequence data.

Note

On the BKDF-902, you can use only still image files and user patterns in the data backed up on the BKDF-901.

Updating the Software

Note

Always power off all devices and unplug all power cords before removing any cable or board.

Preparatory operations

- 1 When using the BKDF-902, confirm that pin 2 of the relevant DIP switch is in the “ON” position.

Note

Pin 1 of this DIP switch is located on the external device interface connector side.

For more information about the DIP switch, see “Changing the Internal Switch Setting in the Processor Unit (When Using the BKDF-902)” on page 54.

- 2 Turn on the POWER switch on the processor unit (DFS-900M) and on the control panel (BKDF-901/902).
- 3 Insert the USB flash drive for software update that contains copied program files into the USB MEMORY connector in the operating block of the control panel.
- 4 See “To back up all data to a USB flash drive” (page 168) and back up all data.

To update control panel software (GUI)

- 1 When using the BKDF-901: If the SHIFT button in the DME/SETUP block is not lit, press it to light it.
- 2 Press the SYSTEM button.
The most recently used sub menu appears in the display panel.
- 3 Press the ◀ and ▶ buttons in the numeric keypad until the Update sub menu appears.

GUI is indicated as CP in the display panel.

Update	Cal.	TG:DSP	Cursor
CP=1.04			

- 4 Press the F1 knob and hold it down for one second or longer.
GUI version update starts with bleep. Subsequently, the GUI software automatically restarts twice.

To update the firmware

- 1 When using the BKDF-901: If the SHIFT button in the DME/SETUP block is not lit, press it to light it.
- 2 Press the SYSTEM button.
The sub menu operated last is shown on the display panel.
- 3 Press the ◀ and ▶ buttons in the numeric keypad until the Update sub menu appears.

Update	Cal.	TG:DSP	Cursor
CP=1.50			

- 4 Turn the F3 knob to select an item to be updated for “TG:.”

For details, “To update the system” (page 170).

Update	Cal.	TG:DSP	Cursor
CP=1.50			

- 5 Press the F3 knob and hold it down for one second or longer.

Firmware version update starts with bleep. During the version update, the STORE button lights in red in the numeric keypad and “Now Updating” appears in the display panel.

Now Updating...	Cal.	TG:DSP	Cursor
CP=1.50			

- 6 Repeat steps 4 and 5 to perform necessary firmware version update.

Upon completion of version update

- 1 Disconnect the USB flash drive from the control panel.
- 2 Turn off the POWER switch on the processor unit (DFS-900M) and on the control panel (BKDF-901/902).

Performing Update Confirmation, Data Clear, and Data Restoration

Upon completion of software update, you need to confirm the updated versions, clear all data in the memory of the control panel, and recall the backup data. Perform the operations in the following order.

To check for correct version update

Perform “Checking the Software Versions” (page 202) to check the current software versions.

To clear (initialize) all data

See “To clear all data from the memory of the control panel” (page 168).

To restore all data

- 1 Connect the USB flash that contains the backup data to the control panel.
- 2 See “To recall all data from a USB flash drive” (page 168) and restore all data using the data backed up before the version update.

- 3 Upon completion of data restoration, disconnect the USB flash drive from the control panel.

Troubleshooting

Problems during Startup

Symptom	Action
Power is not turned on.	Check whether power cables are properly connected to BKDF-901/902 and DFS-900M. After you checked that power cables are properly connected, turn on the power switch of BKDF-901/902. When BKDF-901/902 has started normally, an initialization message appears on the display panel of BKDF-901/902. Then turn on the power switch of DFS-900M. Confirm that the power indicator of DFS-900M lights green.
Communication is disabled with "Prepare communication between CP and PR" displayed on the display panel.	Check whether DFS-900M is powered on. Confirm that the power indicator is lit green and the fans are rotating.
	Confirm that BKDF-901/902 is connected to DFS-900M with the supplied control cable (cross cable). A straight cable cannot be used for connection between BKDF-901/902 and DFS-900M. Use the supplied control cable (cross cable).
	Check whether the LAN cable is properly connected. Confirm that the LAN connector access LED of BKDF-901/902 and DFS-900M is lit green.
	It may take several minutes until communication is started after the unit has started. When communication starts, the LAN connector access LED of BKDF-901/902 and DFS-900M blinks orange. If the LED does not start blinking after a while, turn off the power of DFS-900M and restart it.
	The following messages appear sequentially on the display panel of BKDF-901/902 during startup. <ol style="list-style-type: none">1. Now initializing...Please wait... : After power-on2. Now initial communication was started 0/NNN : After OS has started (NNN: Number of stills)3. When communication with DFS-900M has been established, a value "0" displayed in 2 above is incremented to the same value as NNN.4. The initial menu is displayed. When a communication failure for 0.5 seconds or more occurs in this state, a message "Prepare communication between CP and PR" appears.

Problems on Video Input and Output

Symptom	Action
Output video is disturbed.	Check whether the video format setting is correct. Display the video format menu and confirm that the input signal matches the setting referring to "Setting the Video Format" (page 71). Also check whether the settings of display device (such as monitor) are correct.
	If the video format is changed while the input signal freeze function (including stills) is used, set the freeze function again with the updated video format and download stills.

Symptom	Action
<ul style="list-style-type: none"> Input video is not displayed. Video does not change even when the M/E button row is pressed. 	Check whether the displayed output video is PREVIEW output or CLEAN output video. If AUX output video is displayed, check the assignment of output video with the AUX menu.
	Check the lighting status of the M/E button row and the right-end SHIFT button to see if button is correctly selected.
	Press the INPUT button and check whether the button row assignment has been changed from the Input Remap menu.
	Press the INPUT button and check whether the freeze mode is set to LIVE from the "Input Remap" menu.
	Press the INPUT button and check whether the input process amplifier setting has been changed from the Input Process 1, 2 menu.
	Confirm that the image (including characters) registered by KEY 1 to KEY 4 and DSK1/DSK 2 is not superimposed on the displayed output video. Press the KEY1 to 4 button and the DSK1, 2 button in the transition block to light them. When they are lit red, transition them and clear the setting.
	Confirm that BLACK TRANS is disabled. When the BLACK TRANS button in the transition block is lit orange, press the BLACK TRANS button to clear the setting.
When AUX output video of expansion option is displayed, check whether the up-conversion setting is correct. Similarly when AUX input video of expansion option is displayed, check whether the upconversion setting is correct.	

Problems on Functions

Symptom	Action
<ul style="list-style-type: none"> No key is displayed. Key transition is not enabled. 	Check whether the KEY SOURCE and KEY INSERT settings are correct. Also check whether the DME mode (with KEY / without KEY) setting is correct with the KEYER menu.
	Check whether invisible position and size are set with DME in the KEYER menu. The DME parameter is also changed when preset DME transition is made. Reset the DME parameter or make DME transition.
	Confirm that the current made is not the transition preview mode.
The DME transaction button is pressed, but no response is returned.	Check whether the number of DME channels has not reached the upper limit. The number of DME channels is displayed in "Now Using DMEs=" according to the number of additional expansion option DME boards. (2: No additional DME board / 4: One additional DME board / 6: Two additional DME boards) The number of DME channels can be enabled within the displayed number.
<ul style="list-style-type: none"> Stills cannot be downloaded. Stills are downloaded to a place different from the setting. 	Check whether the download destination was changed during download of stills. Do not change the download destination until the USER/STILL button lights orange.
Editor is connected, but it does not work.	Check whether the EDITOR button of BKDF-901/902 is lit. If it is not lit, press the EDITOR button to light it. Check whether the communication settings are correct. Press the SYSTEM button and check whether the communication protocol, baud rate, and parity bit settings are correct from the Serial menu.

Specifications

Design and specifications are subject to change without notice.

DFS-900M Processor Unit

Signal processing

HD mode/SD mode
HD mode or SD mode can be selected with a menu.

Television system
1080/59.94i, 1080/50i, 720/50p, 720/59.94p
480/59.94i, 576/50i

Signal processing system
4:2:2:4 digital component

Quantization bits
Y: 10 bits, C: 10 bits, KEY: 10 bits

Input/output delay
1 H (when the frame synchronizer is OFF)

Inputs/outputs

Video input BNC type (8), 800 mVp-p, 75 ohms
HD-SDI: 1.485 Gbps or 1.485/1.001 Gbps
SD-SDI: 270 Mbps
The frame synchronizer function is built in for all the inputs.

Reference input BNC type (2), 75 ohms, loop-through
(An external 75-ohm terminator is required.)
BB: NTSC 0.429 Vp-p, PAL 0.45 Vp-p
(Tri-level sync: ± 0.3 Vp-p is available for HD mode.)

Video output BNC type (4), 800 mVp-p, 75 ohms
HD-SDI: 1.485 Gbps or 1.485/1.001 Gbps
SD-SDI: 270 Mbps

Reference output BNC type, 75 ohms
BB: NTSC 0.429 Vp-p, PAL 0.45 Vp-p
(Tri-level sync: ± 0.3 Vp-p is available for HD mode.)

Interfaces

REMOTE D-sub 9-pin (3), female
EDITOR D-sub 9-pin, female
GPI IN D-sub 25-pin, female, 16 inputs
TALLY/GPI OUT D-sub 37-pin, female, 32 outputs

PANEL 30 V DC, 100 mA, open collector
RJ-45 type

General

Power requirements
100 to 240 V AC, 50/60 Hz
Power consumption
400 W (when the maximum number of optional boards are installed)
Current consumption
5.7 to 2.5 A (100 to 240 V AC)
Peak inrush current
(1) Power ON, current probe method: 30 A (100 V), 80 A (240V)
(2) Hot switching inrush current, measured in accordance with European standard EN55103-1: 40 A (230 V)

Operating temperature
5°C to 40°C (41°F to 104°F)

Dimensions (w/h/d)
430 × 132 × 445 mm (17 × 5 1/4 × 17 5/8 inches)

Mass
Approx. 17.3 kg (38 lb 2.2 oz) (not including any optional product and accessory)

Supplied accessories
Control cable (shielded cross cable complied with IEEE 802.3 Ethernet 100BASE-TX standards, for connection between the Processor Unit and Control Panel) (1)
Rack mounting bracket (1 set)
Operating Instructions (1)
Warranty (1)

Accessories not supplied
AC power cord (for USA and Canada): 125 V, 10 A, 2.4 m (7 feet 10 1/2 inches)
Part No. 1-551-812-31
AC power cord (for Europe): 250 V, 10 A, 2.5 m (8 feet 2 1/2 inches)
Part No. 1-782-929-12

BKDF-901 1M/E Control Panel

Interface

Operating panel

USB MEMORY
High Speed USB (USB2.0) Type-A

Rear panel

EXT DISPLAY
High density D-sub 15-pin, female
DEVICE High Speed USB (USB2.0) Type-A
PROCESSOR RJ-45

MAINTENANCE

D-sub 9-pin, male

General

Power requirements

100 to 240 V AC, 50/60 Hz

Power consumption

28 W

Current consumption

0.30 to 0.15 A (100 to 240 V AC)

Peak inrush current

- (1) Power ON, current probe method:
10 A (100 V), 50 A (240 V)
- (2) Hot switching inrush current, measured in accordance with European standard EN55103-1: 10 A (230 V)

Operating temperature

5°C to 40°C (41°F to 104°F)

Dimensions (w/h/d)

430 × 110.1 × 221 mm (17 × 4³/₈ × 8³/₄ inches) (not including the joystick and brackets, etc)

Mass

Approx. 4.4 kg (9 lb 11 oz)

Supplied accessories

- Rack mounting bracket (1 set)
- Operating Instructions (1)
- Warranty (1)

Accessories not supplied

- AC power cord (for USA and Canada):
125 V, 10 A, 2.4 m (7 feet 10¹/₂ inches)
Part No. 1-551-812-31
- AC power cord (for Europe): 250 V,
10 A, 2.5 m (8 feet 2¹/₂ inches)
Part No. 1-782-929-12

Power consumption

40 W

Current consumption

0.34 to 0.17 A (100 to 240 V AC)

Peak inrush current

Inrush current

- (1) Maximum possible inrush current at initial switch-on (Voltage changes caused by manual switching): 60 A peak, 10 A r.m.s. (240 V AC)
- (2) Inrush current after a mains interruption of five seconds (Voltage changes caused at zero-crossing): 10 A peak, 2 A r.m.s. (240 V AC)

Operating temperature

5°C to 40°C (41°F to 104°F)

Dimensions (w/h/d)

595 × 125.5 × 399 mm
(23¹/₂ × 5 × 15³/₄ inches) (not including the joystick and brackets, etc)

Mass

Approx. 9.0 kg (19 lb 13 oz)

Supplied accessories

- Rack mounting bracket (1 set)
- Operating Instructions (1)
- Warranty (1)

Accessories not supplied

- AC power cord (for USA and Canada):
125 V, 10 A, 2.4 m (7 feet 10¹/₂ inches)
Part No. 1-551-812-31
- AC power cord (for Europe): 250 V,
10 A, 2.5 m (8 feet 2¹/₂ inches)
Part No. 1-782-929-12

BKDF-902 1.5M/E Control Panel

Interface

Operating panel

USB MEMORY

High Speed USB (USB2.0) Type-A

Rear panel

- EXT DISPLAY High density D-sub 15-pin, female
- DEVICE High Speed USB (USB2.0) Type-A
- PROCESSOR RJ-45
- MAINTENANCE D-sub 9-pin, male

General

Power requirements

100 to 240 V AC, 50/60 Hz

Optional Products

BKDF-910 4 SDI Input Board

- Video input BNC type (4), 800 mVp-p, 75 ohms
- HD-SDI: 1.485 Gbps or 1.485/1.001 Gbps
- SD-SDI: 270 Mbps
- All input channels provided with frame synchronizer function, and two input channels with up-conversion function.

Power requirements

12 V DC (supplied from the switcher)

Power consumption

30 W max.

Operating temperature

5°C to 40°C (41°F to 104°F)

Dimensions (w/d)

271 × 95 mm (10³/₄ × 3³/₄ inches) (not including the projected parts)

Mass

Approx. 300 g (11 oz)

Supplied accessories

Connector name plate (1)
 +M3 screws (4), +M2.6 screws (4)
 Operating Instructions (1)
 Warranty (1)

BKDF-911 2 SD Video Input Board

Input connectors
 BNC (4), equipped with down-conversion function

Composite inputs
 2 channels, 1.0 Vp-p, 75 ohms

Component input
 1 channel
 SD component
 Y: 1.0 Vp-p, R-Y/B-Y: 0.7 Vp-p, 75 ohms

Power requirements
 12 V DC (supplied from the switcher)

Power consumption
 28 W max.

Operating temperature
 5 °C to 40 °C (41 °F to 104 °F)

Dimensions (w/d)
 271×95 mm (10 3/4 × 3 3/4 inches) (not including the projected parts)

Mass
 Approx. 300 g (11 oz)

Supplied accessories
 Connector name plate (1)
 +M3 screws (4), +M2.6 screws (4)
 Heat transfer sheet (1)
 Operating Instructions (1)
 Warranty (1)

BKDF-912 2 DVI Input Board

Input connectors
 DVI-I (2), female, single link, incompatible with HDCP ¹⁾

Resolution (DVI input)

HD (1920×1080)	HD (1280×720)	SD
–	–	640×480 (VGA)
–	–	800×600 (SVGA)
1024×768 (XGA)	1024×768 (XGA)	1024×768 (XGA)
1280×768 (WXGA)	1280×768 (WXGA)	–
1280×1024 (SXGA)	1280×1024 (SXGA)	–
1600×1200 (UXGA)	–	–
1680×1050 (WSXGA)	–	–
1920×1200 (WUXGA)	–	–

RGB input
 R/G/B: 0.7 Vp-p
 H/V: TTL level

Power requirements
 12 V DC (supplied from the switcher)

Power consumption

38 W max.

Operating temperature
 5 °C to 40 °C (41 °F to 104 °F)

Dimensions (w/d)
 271×95 mm (10 3/4 × 3 3/4 inches) (not including the projected parts)

Mass
 Approx. 300 g (11 oz)

Supplied accessories
 Connector name plate (1)
 +M3 screws (4), hexagon head bolts (5 mm in width across flats) (4)
 Heat transfer sheet (1)
 Operating Instructions (1)
 Warranty (1)

1) High-bandwidth Digital Content Protection

BKDF-940 2 CH DME Board

Power requirements
 12 V DC (supplied from the switcher)

Power consumption
 35 W max.

Operating temperature
 5°C to 40°C (41°F to 104°F)

Dimensions (w/d)
 110 × 130 mm (4 3/8 × 5 1/8 inches) (not including the projected parts)

Mass
 Approx. 200 g (7.1 oz)

Supplied accessories
 +M3 screws (4)
 Heat transfer sheet (1)
 Operating Instructions (1)
 Warranty (1)

BKDF-950 Multi Viewer Board

Power requirements
 12 V DC (supplied from the switcher)

Power consumption
 20 W max.

Operating temperature
 5°C to 40°C (41°F to 104°F)

Dimensions (w/d)
 110 × 130 mm (4 3/8 × 5 1/8 inches) (not including the projected parts)

Mass
 Approx. 200 g (7.1 oz)

Supplied accessories
 +M3 screws (4)
 Operating Instructions (1)
 Warranty (1)

BKDF-960 4 SDI Output Board

Video output
 BNC type (4), 800 mVp-p, 75 ohms
 HD-SDI: 1.485 Gbps or 1.485/1.001 Gbps
 SD-SDI: 270 Mbps
 Of the four output channels, two channels provided with down-conversion function.

Power requirements

12 V DC (supplied from the switcher)
 Power consumption
 20 W max.
 Operating temperature
 5 °C to 40 °C (41 °F to 104 °F)
 Dimensions (w/d)
 271 × 110 mm (10 ³/₄ × 4 ³/₈ inches) (not including the projected parts)
 Mass
 Approx. 400 g (14 oz)
 Supplied accessories
 Connector name plate (1)
 +M3 screws (4), +M2.6 screws (4)
 Operating Instructions (1)
 Warranty (1)

BKDF-961 2 SD Video Output Board

Output connectors
 BNC (4), equipped with down-conversion function
 Composite inputs
 2 channels, 1.0 Vp-p, 75 ohms
 Component input
 1 channel
 SD component
 Y: 1.0 Vp-p, R-Y/B-Y: 0.7 Vp-p, 75 ohms
 Power requirements
 12 V DC (supplied from the switcher)
 Power consumption
 21 W max.
 Operating temperature
 5 °C to 40 °C (41 °F to 104 °F)
 Dimensions (w/d)
 271 × 110 mm (10 ³/₄ × 4 ³/₈ inches) (not including the projected parts)
 Mass
 Approx. 400 g (14 oz)
 Supplied accessories
 Connector name plate (1)
 +M3 screws (4), +M2.6 screws (4)
 Heat transfer sheet (1)
 Operating Instructions (1)
 Warranty (1)

BKDF-962 2 DVI Output Board

Input connectors
 DVI-I (2), female, single link, incompatible with HDCP ¹⁾
 Resolution (DVI input)

HD (1920×1080)	HD (1280×720)	SD
–	–	800×600 (SVGA)
–	1280×768 (WXGA)	–
1280×1024 (SXGA)	1280×1024 (SXGA)	–
1600×1200 (UXGA) ²⁾	–	–
1680×1050 (WSXGA)	–	–

HD (1920×1080)	HD (1280×720)	SD
1920×1080 (HDTV)	–	–
1920×1200 (WUXGA) ²⁾	–	–

RGB input
 R/G/B: 0.7 Vp-p
 H/V: TTL level
 Power requirements
 12 V DC (supplied from the switcher)
 Power consumption
 32 W max.
 Operating temperature
 5 °C to 40 °C (41 °F to 104 °F)
 Dimensions (w/d)
 271 × 110 mm (10 ³/₄ × 4 ³/₈ inches) (not including the projected parts)
 Mass
 Approx. 400 g (14 oz)
 Supplied accessories
 Connector name plate (1)
 +M3 screws (4), hexagon head bolts (5 mm in width across flats) (4)
 Heat transfer sheet (1)
 Operating Instructions (1)
 Warranty (1)

1) High-bandwidth Digital Content Protection
 2) Only digital signals are output. Analog signals are not output.

BKDF-990 Power Supply Unit

Power requirements
 100 to 240 V AC, 50/60 Hz
 Supply voltage
 12 V DC
 Operating temperature
 5°C to 40°C (41°F to 104°F)
 Dimensions (w/h/d)
 405 × 62.5 × 122.5 mm (16 × 2 ¹/₂ × 4 ⁷/₈ inches) (not including the projected parts)
 Mass
 Approx. 3.1 kg (6 lb 13 oz)
 Supplied accessories
 Operating Instructions (1)
 Warranty (1)

RMM-10 Rack Mount Kit

Notes

- Always make a test recording, and verify that it was recorded successfully.
SONY WILL NOT BE LIABLE FOR DAMAGES OF ANY KIND INCLUDING, BUT NOT LIMITED TO, COMPENSATION OR REIMBURSEMENT ON ACCOUNT OF FAILURE OF THIS UNIT OR ITS RECORDING MEDIA, EXTERNAL STORAGE SYSTEMS OR ANY OTHER MEDIA OR STORAGE SYSTEMS TO RECORD CONTENT OF ANY TYPE.
- Always verify that the unit is operating properly before use. SONY WILL NOT BE LIABLE FOR DAMAGES OF ANY KIND INCLUDING, BUT NOT LIMITED TO, COMPENSATION OR REIMBURSEMENT ON ACCOUNT OF THE LOSS OF PRESENT OR PROSPECTIVE PROFITS DUE TO FAILURE OF THIS UNIT, EITHER DURING THE WARRANTY PERIOD OR AFTER EXPIRATION OF THE WARRANTY, OR FOR ANY OTHER REASON WHATSOEVER.

Pin Assignments

DFS-900M Processor Unit

Tally/GPI OUT connector (D-sub 37-pin, female)

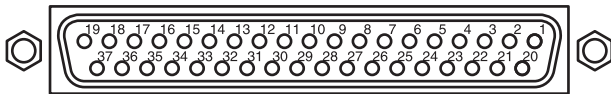

Pin No.	Signal
1	Tally/GPI OUT 1
2	Tally/GPI OUT 2
3	Tally/GPI OUT 3
4	Tally/GPI OUT 4
5	Tally/GPI OUT 5
6	Tally/GPI OUT 6
7	Tally/GPI OUT 7
8	Tally/GPI OUT 8
9	Tally/GPI OUT 9
10	Tally/GPI OUT 10
11	Tally/GPI OUT 11
12	Tally/GPI OUT 12
13	Tally/GPI OUT 13
14	Tally/GPI OUT 14
15	Tally/GPI OUT 15
16	Tally/GPI OUT 16
17	+5V
18	+5V
19	+5V
20	Tally/GPI OUT 17
21	Tally/GPI OUT 18
22	Tally/GPI OUT 19
23	Tally/GPI OUT 20
24	Tally/GPI OUT 21
25	Tally/GPI OUT 22
26	Tally/GPI OUT 23
27	Tally/GPI OUT 24
28	GND
29	GND
30	Tally/GPI OUT 25
31	Tally/GPI OUT 26
32	Tally/GPI OUT 27
33	Tally/GPI OUT 28
34	Tally/GPI OUT 29
35	Tally/GPI OUT 30
36	Tally/GPI OUT 31
37	Tally/GPI OUT 32

For the functions that can be assigned to pins 1 to 16, 20 to 27, and 30 to 37, see “Tally Output Settings” (page 164).

GPI IN connector (D-sub 25-pin, female)

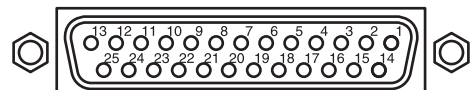

Pin No.	Signal
1	GPI IN 1
2	GPI IN 2
3	GPI IN 3
4	GPI IN 4
5	GPI IN 5
6	GPI IN 6
7	GPI IN 7
8	GPI IN 8
9	GPI IN 9
10	GPI IN 10
11	GPI IN 11
12	GPI IN 12
13	GPI IN 13
14	GPI IN 14
15	GPI IN 15
16	GPI IN 16
17	GND
18	GND
19	GND
20	GND
21	GND
22	GND
23	GND
24	GND
25	GND

For the functions that can be assigned to pins 1 to 16, see “GPI Input Settings” (page 163).

REMOTE (1 to 3) connector (D-sub 9-pin, female)

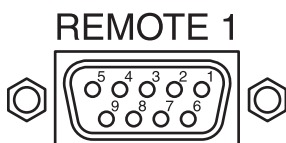

Pin No.	Signal	Function
1	FG	Frame ground
2	R-	Receive data (-)
3	T+	Transmit data (+)
4	SG	Signal ground
5	-	Not used
6	SG	Signal ground
7	R+	Receive data (+)
8	T-	Transmit data (-)
9	FG	Frame ground

EDITOR connector (D-sub 9-pin, female)



Pin No.	Signal	Function
1	FG	Frame ground
2	T-	Transmit data (-)
3	R+	Transmit data (+)
4	SG	Signal ground
5	-	Not used
6	SG	Signal ground
7	T+	Transmit data (+)
8	R-	Receive data (-)
9	FG	Frame ground

BKDF-901/902 control panel

EXT DISPLAY connector (HD-D-sub 5-pin, female)

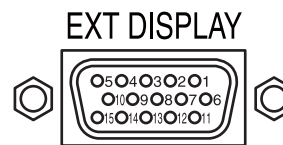

Pin No.	Signal	Function
1	RED	Video signal (Red)
2	GREEN	Video signal (Green)
3	BLUE	Video signal (Blue)
4	-	Not used
5	GND	Signal ground
6	GND	Signal ground
7	GND	Signal ground
8	GND	Signal ground
9	-	Not used
10	GND	Signal ground
11	-	Not used
12	-	Not used
13	H SYNC	Horizontal synchronizing signal
14	V SYNC	Vertical synchronizing signal
15	-	Not used

MAINTENANCE connector (D-sub 9-pin, male)

Provided for inspection / maintenance. Not used for operating this system.

BKDF-912 2 DVI Input Board

DVI IN connector (DVI-I 29-pin)

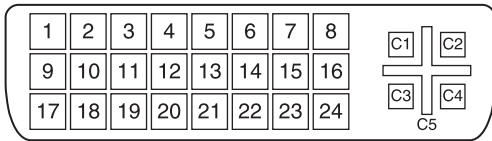

Pin No.	Signal	Function
1	Data 2 –	Digital video signal, red (–)
2	Data 2 +	Digital video signal, red (+)
3	Data 2/4 shield	Shield
4	Data 4 –	Not used
5	Data 4 +	Not used
6	DDC Clock	DDC clock
7	DDC Data	DDC data
8	Analog Vertical Sync	Analog vertical synchronizing signal
9	Data 1 –	Digital video signal, green (–)
10	Data 1 +	Digital video signal, green (+)
11	Data 1/3 shield	Shield
12	Data 3 –	Not used
13	Data 3 +	Not used
14	+5V	+5 V power source
15	Ground	Signal ground
16	Hot Plug Detect	Hot plug signal
17	Data 0 –	Digital video signal, blue (–)
18	Data 0 +	Digital video signal, blue (+)
19	Data 0/5 shield	Shield
20	Data 5 –	Not used
21	Data 5 +	Not used
22	Clock shield	Clock shield
23	Clock +	Digital clock signal (+)
24	Clock –	Digital clock signal (–)
C1	Analog Red	Analog video signal, red
C2	Analog Green	Analog video signal, green
C3	Analog Blue	Analog video signal, blue
C4	Analog Horizontal Sync	Analog horizontal synchronizing signal
C5	Analog Ground	Analog signal ground

BKDF-962 2 DVI Output Board

DVI OUT connector (DVI-I 29-pin)

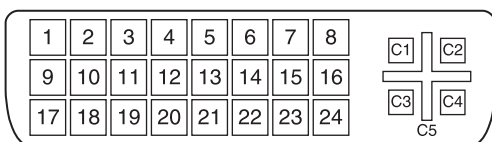

Pin No.	Signal	Function
1	Data 2 –	Digital video signal, red (–)
2	Data 2 +	Digital video signal, red (+)
3	Data 2/4 shield	Shield
4	Data 4 –	Not used
5	Data 4 +	Not used
6	DDC Clock	DDC clock
7	DDC Data	DDC data
8	Analog Vertical Sync	Analog vertical synchronizing signal
9	Data 1 –	Digital video signal, green (–)
10	Data 1 +	Digital video signal, green (+)
11	Data 1/3 shield	Shield
12	Data 3 –	Not used
13	Data 3 +	Not used
14	+5V	+5 V power source
15	Ground	Signal ground
16	Hot Plug Detect	Hot plug signal
17	Data 0 –	Digital video signal, blue (–)
18	Data 0 +	Digital video signal, blue (+)
19	Data 0/5 shield	Shield
20	Data 5 –	Not used
21	Data 5 +	Not used
22	Clock shield	Clock shield
23	Clock +	Digital clock signal (+)
24	Clock –	Digital clock signal (–)
C1 ^{a)}	Analog Red	Analog video signal, red
C2 ^{a)}	Analog Green	Analog video signal, green
C3 ^{a)}	Analog Blue	Analog video signal, blue
C4	Analog Horizontal Sync	Analog horizontal synchronizing signal
C5	Analog Ground	Analog signal ground

a) When you select “HDTV” for DVI output signals (page 85), the following signals are output.

C1: Color differential signal, Pr

C2: Luminance signal, Y

C3: Color differential signal, Pb

Example Connection of GPI Input

Switch or relay connection

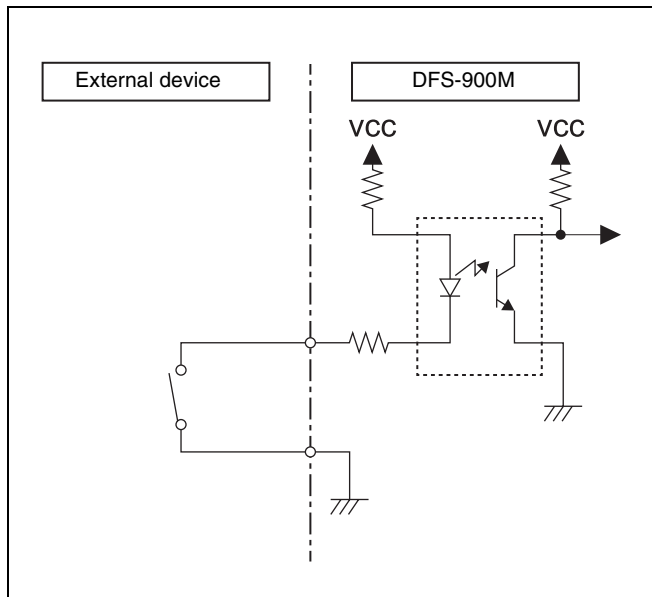

Example Connection of Tally/GPI Output

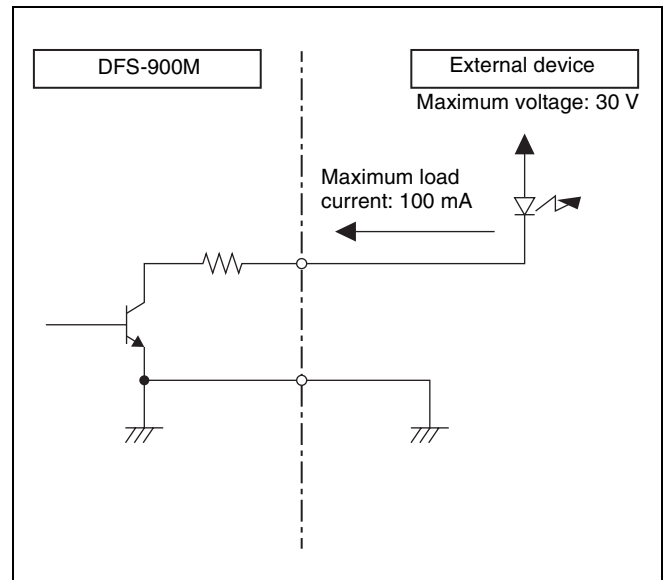

Open collector connection

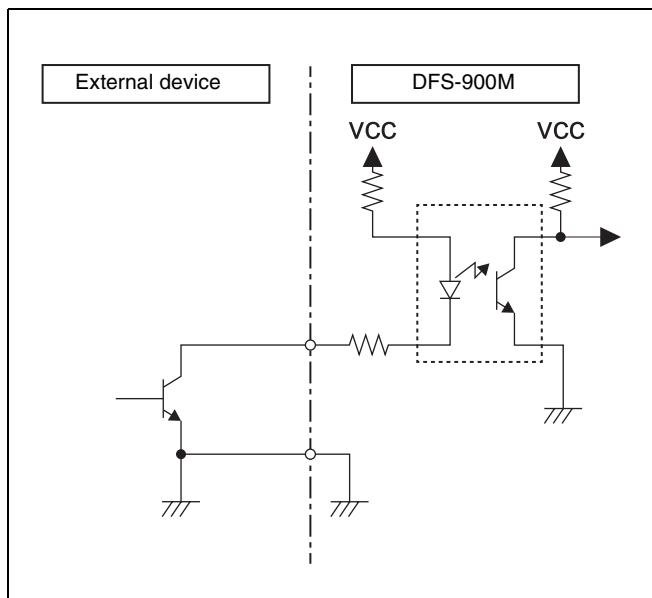

External Dimensions

BKDF-901 1M/E Control Panel

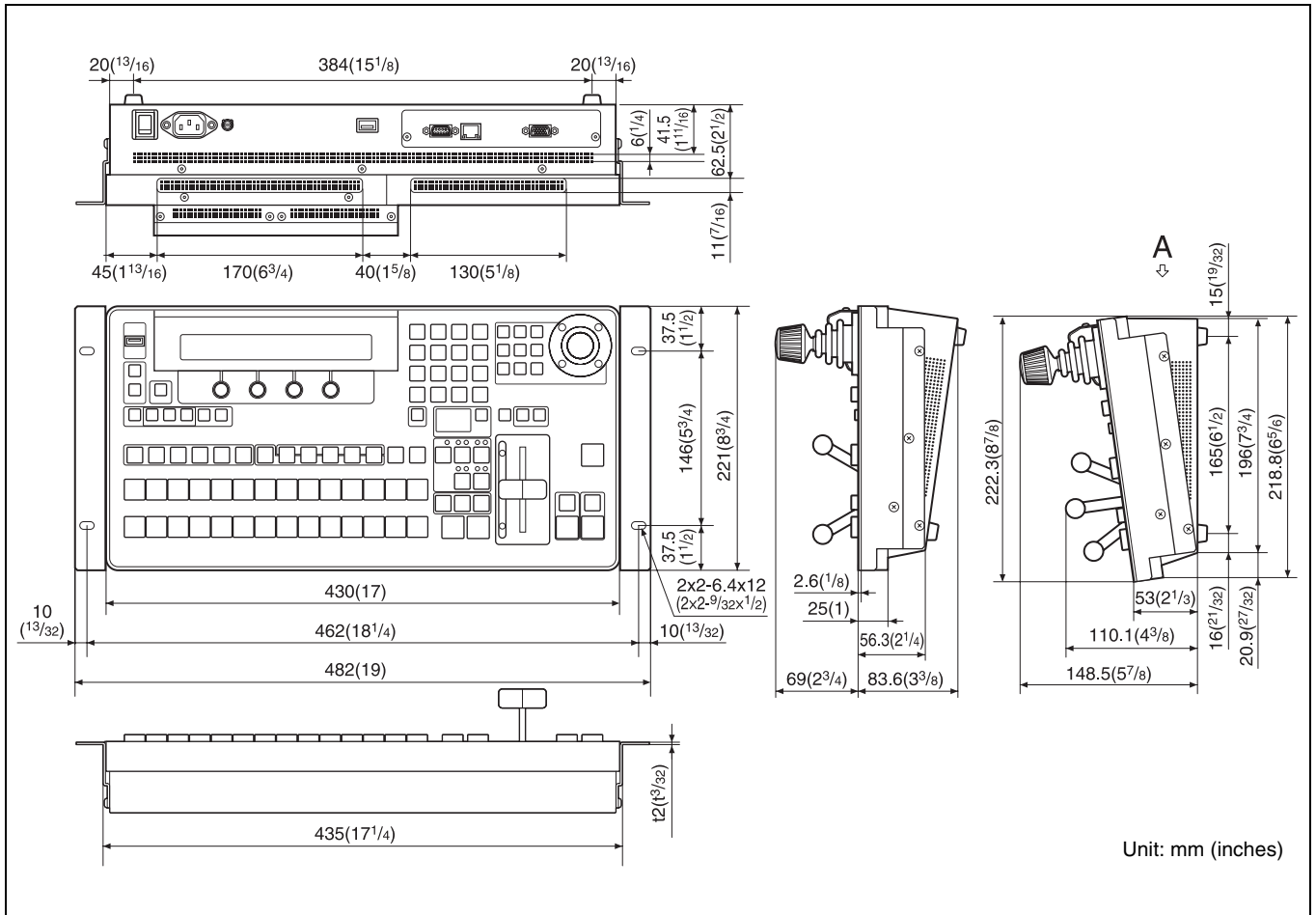

BKDF-902 1.5M/E Control Panel

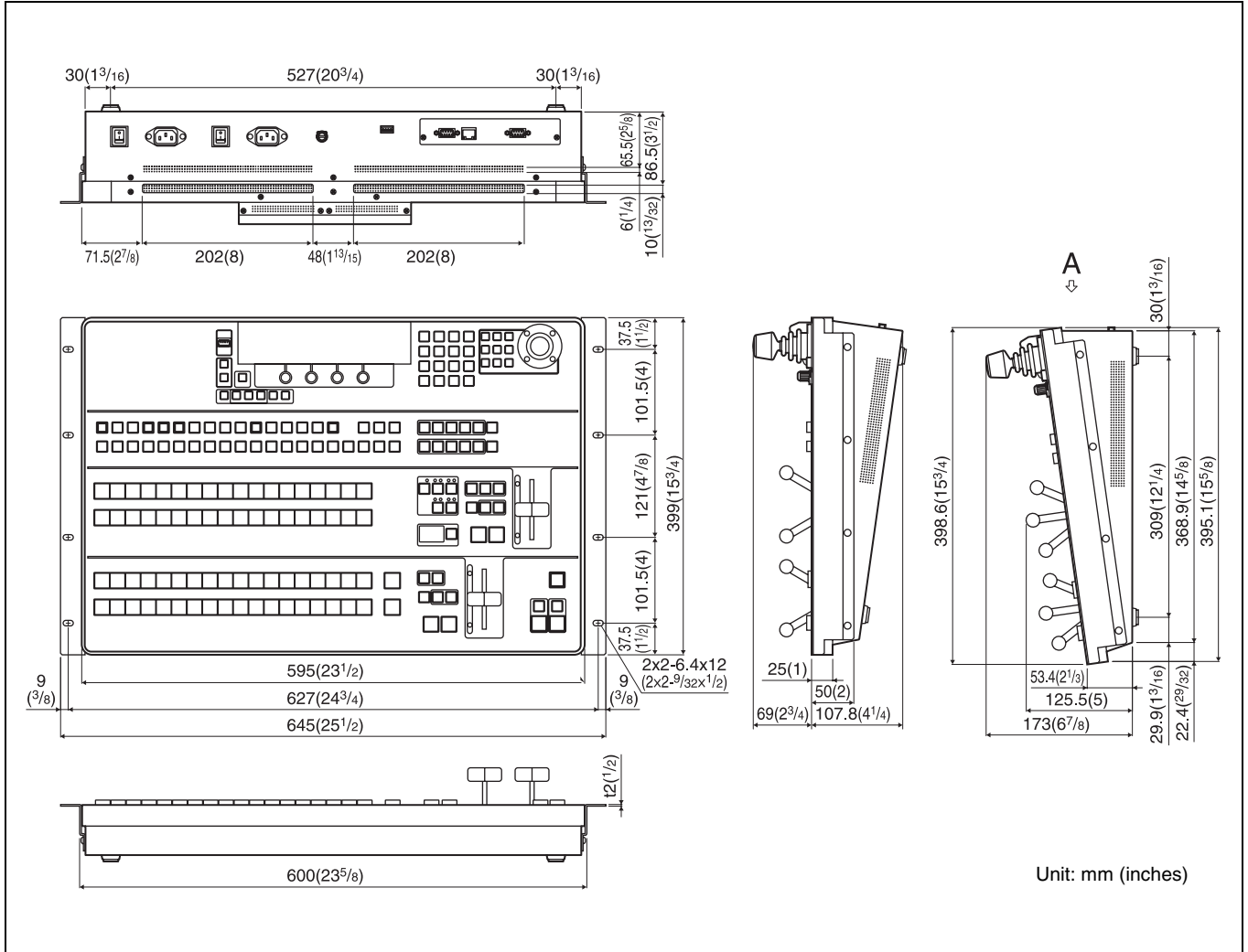

DFS-900M Processor Unit

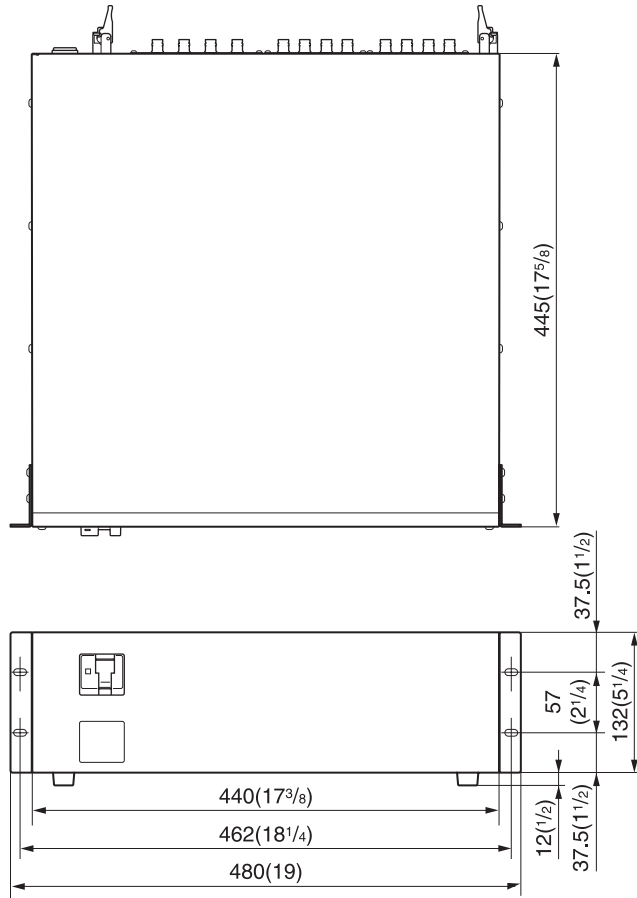

Unit: mm (inches)

Glossary

AUX output

A signal output from an AUX (auxiliary) connector to an external device.

Background transition

A transition that switches away from the background video of the current program output to other video.

Color matte

An internally generated color signal. You can adjust the hue (Hue), saturation (Sat), and luminance (Lum) of color mattes.

DME (digital multi effects)

A special effect (3D, lighting, etc.) created with digital video processing.

DME wipe

A wipe that uses a DME effect to switch between video signals.

Downstream key (DSK)

A function which allows video to be composed by taking video to which an effect has already been applied and adding further images and text. It is called downstream key because this processing is done as the last stage in the flow of video processing.

Event

A set of control panel settings registered as data. You can register video selections and effect settings as events, and then automatically restore the same state by recalling the event.

Fade to black

An effect in which video fades out to a black screen.

Key

An effect in which part of the video is cut out and replaced by an image, text, or other content.

Key transition

A transition in which a key is inserted into or deleted from the program video.

Mix

A type of transition effect. Another video signal is mixed into the current video signal, gradually replacing it.

Preset bus

A bus for the video signal that will become the program video after a background transition. This video is selected and output before execution of the transition.

Preview output

Output that allows you to check the program video that will appear after a transition, before actual execution of the transition.

Program bus

A bus for the output of program output signals.

Program output

The final video signal output from this system after applying effects. The video seen by viewers.

Sequence

A set of control panel settings stored as motion video. The settings for a single instant are stored as a single frame of the video. The sequence is played by recalling the frames in turn, with the video changing smoothly between the current frame and the next frame.

Still image memory

Internal memory for storing image data as files.

Transition

Switching from one video signal to a different video signal over a certain time interval. Transitions can be used to compose or erasing graphics or text using functions such as downstream keys or Picture-in-Picture.

Wipe

A type of transition effect. A new video signal replaces the current video signal by gradually wiping it away.

Index

Numerics

- 32-bit TGA 120
- 3D effects 140
- 3D mode 172
 - operation 175
- 4:3BGS 83

A

- AC power cord 57
- Analog video signal
 - Input setting 83
 - Output setting 92
- Ancillary data 89
- Assign
 - AUX output 89
- Assigning
 - PROGRAM and PRESET selection button 76

B

- Background
 - selecting 108
 - switching 109
- Backup 167
- Basic operations 108
- Baud rate 162
- BKDF-901 13
- BKDF-902 21
- BKDF-910 31
 - Up converter setting 81
- BKDF-911 31
 - Input signal setting 83
 - Up converter setting 81
- BKDF-912 31
 - Input signal setting 85
- BKDF-940
 - installation position 46
- BKDF-950
 - installation position 46
 - setting 96
- BKDF-960 31
 - Down converter setting 91
- BKDF-961 31
 - Down converter setting 91
 - Output signal setting 92
- BKDF-962 32
 - Output signal setting 94
- BKDF-990 32
 - installing/removing 51
 - POWER switch and indicator 28
- Boot mode 59

- Border
 - adjusting color 138
 - beveled edge 139
 - DME wipe pattern 137
 - highlight 139
 - inner width 138
 - outer width 138
 - softness 139
 - wipe pattern 132
- Box mask 150
- Box Mask sub menu 150

C

- Capture 119
- Channel number 39
 - Input expansion board 40
 - Output expansion board 41
- Chroma key 123
- Color matte 117
 - background transition 118
 - changing 117
- Communication protocol 162
- Connection
 - mouse 65
 - PC monitor 65
 - peripheral device 33
 - switcher system 54
 - touch panel monitor 65
- Control panel 13, 21
 - connecting 57
 - external connection block 14, 22
 - operating blocks 13, 21
 - power block 14, 22
 - rear panel 19, 26
- Coordinates 134
- Cross-point bus block 15
- Cross-point selection buttons
 - assigning signals 76
- Cut 109
 - downstream key 129
 - key 126

D

- Data
 - backup 167
 - clearing 167
 - recalling 167
- Defocus 145
- dfs900.ini 75
 - adjusting display position/display size 99
- DFS-900M 28
- Dimensions 215
- Display panel 19, 26, 60, 64
- Display panel/menu control block 26
- Displaying

- menu 63
- DME
 - adjusting position 136
 - aspect ratio 136
 - border 137
 - crop 137
 - customizing 134
 - defocus 145
 - enable/disable 137
 - key 129
 - lens 143
 - lighting effects 146
 - mirror 145
 - mosaic 142
 - page peel 144
 - page turn 143
 - registering user pattern 147
 - ripple 141
 - rotation angle 136
 - setup 137
 - slats 142
 - splits 144
 - swirl 142
 - warp effects 140
- DME Basic sub menu 134
- DME menu
 - reset 134
 - restoring the default values 134
- DME/SETUP block 18, 25
- Downstream key 129, 130
 - box mask 150
 - DSK preview function 103
 - DSK/fade to black control block 24
- DSK/fade to black control block 24
- DVI boards 209, 210
- DVI signal
 - Input setting 85
 - Output setting 94

E

- Edge
 - key 148
- Edge Shadow sub menu 148
- Event
 - deleting 155
 - recalling event 152
 - register 151
- Expansion board installation tray 39
- External control 161
- External device interface connector 29

F

- Fade to black 131
 - DSK/fade to black control block 24

Features 11
Frame synchronizer 79
 capturing still image 80
Function expansion board
 installing/removing 46

G

Global coordinates
 enable/disable 137
GPI input 163
GPI output 166
GUI menu
 connecting devices for display and
 operation 65
GUI menu screen
 basic operations 69
 configuration 68

H

HD/SD-SDI boards 208, 209
Heat transfer sheet
 BKDF-940 48
 I/O expansion board 43

I

I/O expansion board
 installing/removing 39
I/O expansion board slot 39
I/O expansion slot 28
Input board 31
Input signal
 adjusting level 87
 capturing still image 80
 changing signal display name 74
 inputting up-convert 81
 setting 74
Interface 161

J

Joystick block 16, 26

K

Key 122
 adjusting 132
 changing priorities 128
 chroma key 123
 composing video 122
 cut 126
 DME 129
 downstream key 129, 130
 edge 148
 KEY DELEGATION block 15
 Key/AUX bus control block 22
 KEYER block 22

 mask 147
 mix 127
 setting up 122
 type 122
 wipe 127

KEY DELEGATION block 15

Key delegation block 15
Key Mask sub menu 147
Key/AUX bus control block 22
KEYER block 14, 22
Keyer menu 63
Keyframe
 adding 159
 deleting 160

L

Lens 143
Light 1 146
Light 2 146
Light source
 position/size/color 146
 type 146
Light sub menu 146
Lighting effects 146

M

M/E cross-point bus block 23
M/E transition block 25
Mask
 key 147
Memory for the storage of still image
 118
 acquiring still image files 118
 capturing 119
 downloading still image 118
Menu 63
 basic configuration 63
 display panel 19
 display panel/menu control block
 26
 displaying 63
 GUI menu screens 64
 menu control block 19
 operating 64
Menu control block 19, 26
Menu structure 176
Messages 197
Mirror 145
Mix 113
 downstream key 130
 key 127
Modify
 wipe pattern 133
Mosaic 142
Multi-view output
 adding frame 101

 adjusting display position/display
 size 99
 child window number 99
 setting 96
 window partition type 99

N

Names and functions of parts 13
Numeric keypad 17, 26

O

Optional accessories 208
Options 31, 39
 BKDF-901 13
 BKDF-902 21
 BKDF-910 31, 39
 BKDF-911 31
 BKDF-912 31
 BKDF-940 39
 BKDF-950 39
 BKDF-960 39
 BKDF-961 31
 BKDF-962 32
 BKDF-990 32, 39
I/O expansion slot 28
input board 31
installing 39
output board 31
 POWER switch and indicator 28
Output Board 31
Output signal 89
 assigning to AUX output 89
 down-convert output 91

P

Page Peel 144
Page Turn 143
Parity bit 162
Pin assignments 211
Power
 off 60
 on 58
Power block 14, 22
 control panel 14, 22
Power connectors 30
Power supply unit 32
 installing/removing 51
POWER switch
 control panel 59
 processor unit 59
POWER switch and indicator 28
 power supply unit 32
POWER switches (A and B) 26
PRESET selection button 15
Processor unit 28
 connecting 57

- front panel 28
- power connectors 30
- POWER switch and indicator 28
- rear panel 28
- PROGRAM selection button 15
- PROGRAM/PRESET cross-point bus block 23
- PROGRAM/PRESET transition block 24

R

- Reference sync signal
 - setting 73
- Register
 - event 151
 - operation/setting 151
 - user pattern 133, 147
- Ripple 141

S

- SD boards 209, 210
- Sequence
 - creating 156
 - deleting 160
 - editing 159
 - playing 158
 - recalling 156
- Sequence/Event menu 63
- Serial interface 161
- Settings 71
 - Analog video signal 83, 92
 - BKDF-950 96
 - cross-point bus block 105
 - down-converter 91
 - DSK preview function 103
 - DVI signal 85, 94
 - frame synchronizer 79
 - input signal 74
 - internal clock 106
 - M/E cross-point bus block 23
 - output signal 89
 - PROGRAM/PRESET cross-point bus block 23
 - reference sync signal 73
 - timing of video switching 104
 - up-converter 81
 - video format 71
- Setup menu 63
- SHUTDOWN button 61
- Shutdown processing 61
- Signal display name
 - changing 74
 - usable characters 76
- Slats 142
- Source coordinates 134
- Specifications 207

- Splits 144
- Standard I/O module 29, 46
 - DME1, DME2 sockets 46
 - MV1, MV2 sockets 46
- Still image
 - 32-bit TGA 120
 - acquiring still image files 118
 - background transition 120
 - capturing 80, 119
 - deleting 121
 - downloading 118
 - writing to USB flash drive 121
- Still Store menu 63
- Sub menu 63
 - displaying 64
- Swirl 142
- System 169

T

- Tally output 164
- Target coordinates 134
- Touch panel monitor
 - calibration 66
 - connecting 65
- Transition 109
 - cut 109
 - M/E transition block 25
 - mix 113
 - PROGRAM/PRESET transition block 24
 - transition block 15
 - wipe 115
- Transition block 15
- Transition menu 63
- Transition rate 117
- Troubleshooting 205
- Type 146

U

- Up-converter 81
- Update 169
- Updating software 202
- USB flash drive 75
 - recalling all event data 154
 - recalling event in page unit 154
 - saving event data 152
 - writing still image 121
- USB MEMORY connector 75
- User patterns
 - registering 133, 147
- User sub menu 133, 147

V

- Video format 71
 - when an SD format is selected 72

W

- Warp effects 140
- Warp sub menu 140
- Wipe 115
 - adjusting 132
 - customizing wipe pattern 132
 - key 127
- Wipe Border Color sub menu 132
- Wipe Modify sub menu 133
- Wipe pattern
 - adjusting position 133
 - aspect ratio 133
 - border 132
 - customizing 132
 - modifying 133
 - registering user pattern 133
 - rotation angle 133
- Wipe Pattern sub menu 132