

SONY®

SONY®

Multi Format Switcher System

**MFS-2000**

**MFS-2000**

User's Guide 1st Edition (Revised 3)

User's Guide English  
1st Edition (Revised 3)

MADE IN JAPAN

3-855-579-04(1)

**SONY®**

Multi Format Switcher System

# **MFS-2000 System**

**(With MKS-2010/MKS-2015/MKS-2017 Control Panel)**

User's Guide English

1st Edition (Revised 3)

Software Version 4.00 and Later

## **NOTICE TO USERS**

© 2004 Sony Corporation. All rights reserved.

This manual or the software described herein, in whole or in part, may not be reproduced, translated or reduced to any machine readable form without prior written approval from Sony Corporation.

SONY CORPORATION PROVIDES NO WARRANTY WITH REGARD TO THIS MANUAL, THE SOFTWARE OR OTHER INFORMATION CONTAINED HEREIN AND HEREBY EXPRESSLY DISCLAIMS ANY IMPLIED WARRANTIES OF MERCHANTABILITY OR FITNESS FOR ANY PARTICULAR PURPOSE WITH REGARD TO THIS MANUAL, THE SOFTWARE OR SUCH OTHER INFORMATION. IN NO EVENT SHALL SONY CORPORATION BE LIABLE FOR ANY INCIDENTAL, CONSEQUENTIAL OR SPECIAL DAMAGES, WHETHER BASED ON TORT, CONTRACT, OR OTHERWISE, ARISING OUT OF OR IN CONNECTION WITH THIS MANUAL, THE SOFTWARE OR OTHER INFORMATION CONTAINED HEREIN OR THE USE THEREOF.

Sony Corporation reserves the right to make any modification to this manual or the information contained herein at any time without notice.

The software described herein may also be governed by the terms of a separate user license agreement.

---

# Table of Contents

---

## Chapter 1 Overview

Introduction .....	7
System Features .....	7
Options .....	8

---

## Chapter 2 Names and Functions of Parts

<b>Control Panel Types .....</b>	<b>9</b>
<b>Control Panel Configuration .....</b>	<b>11</b>
M/E Cross-Point Control Block.....	12
PGM/PST Cross-Point Control Block .....	14
AUX Bus Control Block.....	15
M/E Transition Control Block .....	16
PGM/PST Transition Control Block.....	18
M/E Key Transition Control Block.....	19
Downstream Key/Fade to Black Control Block .....	19
Flexi Pad Control Block.....	20
Effect/Wipe Control Block .....	22
Utility Control Block .....	24
Macro Control Block .....	24
Menu Control Block .....	25
Power Indicators, “Memory Stick” Slot, USB Connector .....	25
<b>“Memory Stick” .....</b>	<b>26</b>
Usable “Memory Stick” .....	26
Handling “Memory Stick” .....	26

---

## Chapter 3 Using Menus

<b>Accessing Menus.....</b>	<b>27</b>
Accessing Menus From the Top Menu .....	27
Accessing Menus by Double Clicking.....	28
Accessing Menus by Single Clicking .....	31
<b>Interpreting Menu Screens.....</b>	<b>32</b>
Basic Screen.....	32
Popup Windows .....	36
<b>Basic Menu Operations .....</b>	<b>43</b>
Selecting Menus.....	43
Selecting Functions .....	44
Setting Parameters .....	44
Returning Setting Data to Default Values ..	46
<b>Exiting the Menu System .....</b>	<b>47</b>

---

## Chapter 4 Basics of Video Switching

<b>Basic Operations (1): Video Switching on the M/E Bank .....</b>	<b>50</b>
<b>Basic Operations (2): Video Switching on the PGM/PST Bank — For 1.5 M/E Systems .....</b>	<b>53</b>

---

## Chapter 5 Basic Operations

<b>Selecting Video .....</b>	<b>55</b>
Flow of Operations.....	55
Selecting Video in the M/E Cross-Point Control Block .....	56
Selecting Video in the PGM/PST Cross-Point Control Block .....	57
Selecting Video in the AUX Bus Control Block .....	57
<b>Selecting Transition Types .....</b>	<b>59</b>
Flow of Operations.....	59
Selecting the Transition Type and the Next Transition .....	60
<b>Selecting Effects .....</b>	<b>63</b>
Flow of Operations.....	63
Selecting Effects With the Flexi Pad Control Block .....	64
Selecting Effects From Menus.....	65
Effect Types .....	67
Selecting Channels.....	68
<b>Changing the Position and Size of Effect Patterns .....</b>	<b>70</b>
Flow of Operations.....	70
Changing Pattern Position and Size With the Joystick.....	71
Changing Pattern Size and Position From Menus .....	72
<b>Modifying Video Borders .....</b>	<b>73</b>
Flow of Operations.....	73
Adding Borders to Video .....	74
Softening Video Edges (Soft Edge/Soft Border) .....	75
<b>Preparing Transitions.....</b>	<b>76</b>
Flow of Operations.....	76
Setting Transition Rates .....	76
Selecting Effect Directions .....	78
<b>Executing Transitions .....</b>	<b>80</b>

Flow of Operations .....	80
Executing Transitions .....	80
<b>Composing Video With Keys .....</b>	<b>83</b>
Flow of Operations .....	83
M/E Keys and Downstream Keys.....	84
Inserting Text With a Luminance Key or Linear Key .....	84
Composing Video With Chroma Keys .....	88
Composing Video With Pattern Keys.....	89
Adding Borders to Keys .....	90
Masking Part of a Key .....	91
Moving a Key Over or Under.....	92
Inserting and Deleting Keys Only .....	93
<b>Using Internally Generated Signals .....</b>	<b>95</b>
Flow of Operations .....	95
Using a Color Background .....	95
<b>Fading the Video to Black .....</b>	<b>100</b>
Flow of Operations .....	100

## Chapter 6 Advanced Operations

<b>Advanced Effect Operations .....</b>	<b>103</b>
Transforming Effect Patterns.....	103
Cropping Effects.....	105
Adding Beveled Edges to Video.....	106
Adding Lighting.....	108
Adding Afterimages (Trail).....	109
Adding Shadows Around Effects .....	110
Selecting the interpolation methods.....	111
Composing a Video Border Color From Two Colors .....	112
Using Pattern Specific Transformations... ..	112
Using User Programmable DME Effects .	112
Making the Pattern Limit Setting .....	113
Saving, Recalling, and Deleting Effect Snapshots .....	114
Editing Effect Snapshot Registers .....	115
<b>Advanced Key Operations.....</b>	<b>117</b>
Processing Key Signals.....	117
Adjusting Key Borders .....	118
Adjusting Chroma Keys .....	118
Transforming the Pattern of a Pattern Key	121
Setting Key Mask Shapes and Positions... ..	121
Using the Show Key Function.....	122
Using Key Memory .....	122
<b>Using an Effect for an Independent Key Transition.....</b>	<b>123</b>
Overview.....	123
Assigning the Buttons Used (Setup).....	124

Selecting the Effect for an Independent Key Transition .....	124
Making Detailed Settings for an Independent Key Transition Effect.....	125
<b>Using the Flexi Pad Control Block for an In- dependent Key Transition .....</b>	<b>125</b>
<b>Color Correction.....</b>	<b>126</b>
Selecting the Color Correction Signal .....	126
Output of Color Correction Results .....	126
Flow of Color Correction Operations .....	126
CCR Menu .....	127
Input Video Processing .....	128
Primary Color Correction .....	128
Secondary Color Correction .....	130
RGB Clip .....	130
Luminance Processing .....	131
Spot Color Adjustment .....	132
Output Video Processing .....	133
YUV Clip.....	133
<b>Frame Memory (Still Image File).....</b>	<b>134</b>
Overview.....	134
Flow of Frame Memory Operations .....	135
Preparations .....	135
Selecting Input Signals for Frame Memory .....	135
Freezing Images and Saving Them to Memory .....	136
Recalling Still Images Saved in Frame Memory .....	137
Composing Frame Memory Video .....	138
Changing the Screen Position of the Output Video .....	140
Recording a Series of Images in Frame Memory .....	141
Recalling Recorded Still Images Sequentially .....	142
<b>Frame Memory (Clip) .....</b>	<b>144</b>
Overview.....	144
Clip Creation.....	144
Recalling Clips.....	144
Clip Playback.....	145
Using Utility Control Block for Clip Operations .....	145
<b>Image File Operations.....</b>	<b>146</b>
<b>Clip Transition .....</b>	<b>149</b>
<b>External Hard Disk Drive Access.....</b>	<b>151</b>
Hard Disk Formatting .....	151
Saving frame memory files to the External Hard Disk .....	152

Recalling Files From the External Hard Disk .....	152	Loading All Data at Once .....	180
<b>Snapshots.....</b>	<b>153</b>	Deleting All Data at Once .....	181
Overview .....	153	<b>Batch Operating on Data Files of Selected Categories .....</b>	<b>181</b>
Saving Snapshots .....	154	Saving the Data of Selected Categories ....	181
Recalling Snapshots .....	155	Loading the Data of Selected Categories ..	182
Deleting Snapshots.....	156	Deleting the Data of Selected Categories ..	182
Editing Snapshot Registers .....	156	<b>Operating on Individual Data Files.....</b>	<b>183</b>
Setting Snapshot Attributes.....	157	Loading Data Files .....	183
<b>Timeline Function .....</b>	<b>159</b>	Saving Data Files .....	183
Overview .....	159	Deleting Data Files.....	184
Flow of Timeline Operations .....	159	Renaming Data Files .....	185
Preparations for Timeline Operations .....	160	Copying Data Files.....	186
Recalling the Register in Which You Want to Save the Timeline.....	160	<b>Importing and Exporting Data .....</b>	<b>187</b>
Displaying the Timeline Menu .....	161	Importing Image Files .....	187
Switching Menus in Timeline Operations	161	Importing DME Effects .....	189
Selecting the Region for Timeline Editing	161	Exporting Image Files .....	189
Inserting Keyframes to the Timeline .....	162	<b>Directory Operations .....</b>	<b>190</b>
Specifying Edit Points and Editing Ranges on the Timeline .....	163	Creating Directories .....	190
Editing Keyframes on the Timeline .....	163	Renaming Directories .....	191
Setting Times on the Timeline .....	165	Deleting Directories .....	191
Setting a Path on the Timeline .....	166	Disabling Editing in Directory Units (Locking Directories).....	191
Saving Timeline Data .....	167	Common Operations – Selecting Categories, Media, and Directories .....	191
Recalling Timeline Data .....	167	<b>External Media Support.....</b>	<b>192</b>
Executing a Timeline Effect .....	168	Formatting Media.....	192
Deleting Timeline Data.....	168		
Editing Timeline Registers .....	169		
<b>Macros .....</b>	<b>169</b>		
Overview .....	169		
Creating a New Macro .....	170		
Recalling a Macro Register and Executing a Macro .....	172		
Editing a Macro.....	173		
Saving a Macro .....	174		
Deleting a Macro.....	174		
Using Macro Attachment.....	175		
Editing Macro Registers .....	176		
<b>Safe Title .....</b>	<b>178</b>		
<b>Copying.....</b>	<b>178</b>		
Copy Operation Targets .....	178		
Using Buttons to Copy Key Settings .....	178		

---

## Chapter 7 File Operations

<b>Overview .....</b>	<b>179</b>
<b>Batch Operating on Data Files.....</b>	<b>180</b>
Saving All Data at Once .....	180

---

## Chapter 8 External Device Operations

<b>Control From Editing Systems .....</b>	<b>193</b>
Overview .....	193
Controllable Functions .....	193
Preparations.....	193
<b>Operation From an Editing Keyboard ...</b>	<b>194</b>
<b>Controlling External Devices .....</b>	<b>195</b>
Overview .....	195
Manual VTR/Disk Recorder/Extended VTR Operations .....	195
Checking VTR, Disk Recorder, and Extended VTR Information .....	196
Disk Recorder/Extended VTR File Operations .....	197
<b>Simple Connection to MKS-8080/8082 AUX Bus Remote Panel .....</b>	<b>199</b>

## Chapter 9 System Settings

<b>Basic Settings</b> .....	<b>201</b>
Format Settings (Format Menu) .....	201
Setting the Startup Mode (Startup Mode Menu).....	202
Output Signal Assignment (Output Assign Menu).....	203
Assigning Signals to Cross-Point Buttons (Operation Menu).....	204
Saving Setup (Startup Mode Menu) .....	208
<b>Installing Software</b> .....	<b>209</b>
Displaying Version Information (Version Information Menu).....	209
Displaying Detail Information (Detail Information Menu).....	209
Manually Installing Software (Manual Install Menu).....	209
Entering an Installation Key (License Menu) .....	210
<b>Other Settings</b> .....	<b>212</b>
Setting the Date and Time (Date/Time Menu) .....	212
Panel Maintenance (Panel Menu).....	212
System Adjustments (System Adjust Menu) .....	213
System Reset and Memory Initialization (Initialize Menu) .....	214
Input Signal Setup (Input/Output Menu)..	214
Output Signal Setup (Input/Output Menu)	215
Utility Settings (Utility Menu) .....	218
Key Setup (Key Menu).....	221
Settings Relating to Video Switching (Transition Menu) .....	223
Macro Execution Mode Settings (Macro Menu).....	224
Snapshot/Timeline Settings (Snapshot/Timeline Menu) .....	225
Button Assignments (Button Assign Menu) .....	225
GPI Input/Output Setup (GPI Menu).....	227
Tally Setup (System Tally Menu).....	234
External Device Connection Port Setup (Device Menu) .....	239
<b>Index</b> .....	<b>244</b>

## Introduction

This manual is the User's Guide for the MFS-2000 Multi Format Switcher system.

The MFS-2000 system is comprised of the MFS-2000 Multi Format Switcher Processor, the main unit, and optional system devices such as control panels and system boards.

In place of the official device names, this manual refers to the devices in the system by the names shown in the following table.

Official device name	Name used in this manual
MFS-2000 Multi Format Switcher Processor	Switcher or processor
MKS-2010 1 M/E Control Panel	Control panel or 1 M/E panel
MKS-2015 1.5 M/E Control Panel	Control panel or 1.5 M/E panel <sup>a)</sup>
MKS-2017 1.5 M/E Wide Control Panel	Control panel or 1.5 M/E wide panel <sup>a)</sup>
MKS-2470 DME Board Set	DME or DME option
DCU-8000 Device Control Unit (MKS-8700)	DCU or MKS-8700
DCU-2000 Device Control Unit (MKS-2700)	DCU or MKS-2700

a) The term "1.5 M/E system" refers to systems using either the 1.5 M/E panel or the 1.5 M/E wide panel.

## System Features

The MFS-2000 system is a compact multi-format switcher system supporting numerous HD and SD signal formats. The principal features of this system are as follows.

### Multi-format support

Support for the 480i/59.94 and 576i/50 formats is standard. The optional BZS-2000M Switcher Upgrade Software can be installed to provide support for the following formats.

- 1080i/50, 59.94
- 1080PsF/23.976, 24, 25, 29.97
- 720p/50, 59.94

### State of the art special effects

In its standard configuration, the system supports a wide variety of effect patterns, including advanced wipes. Installation of the optional MKS-2470 DME Board Set makes a further array of advanced effects available, such as flip tumble, page turn, and 2ch P in P (two-channel picture-in-picture).

### Comprehensive keying capabilities

The system is equipped with two keyers and two downstream keyers. All keyers support chroma keying and special key transitions, independent of background transitions ("independent key transitions").

### Optimal for use in live broadcast environment

#### Compact and lightweight

Both control panels and processor are compact and lightweight, designed for use where space is limited. This is the optimal system for use in small-scale outdoor broadcast vans and editing suites.

## Outstanding ease of use

Buttons and other controls on the control panels are grouped in easy to understand functional blocks, facilitating the quick decisions that must be made in a live broadcast environment.

The menu control block features a 6.5-type color LCD touch panel, for quick menu operation.

## Selection of optimal control panel

Any of the following three control panels can be selected for the optimal match to the intended applications and working environment.

- MKS-2010
- MKS-2015
- MKS-2017

*See page 10 for the principal differences between these control panels.*

# Options

The following options are available for the MFS-2000 system.

- MKS-2010 1 M/E Control Panel
- MKS-2015 1.5 M/E Control Panel
- MKS-2017 1.5 M/E Wide Control Panel
- MKS-2110M Input/Output Connector Board
- MKS-2470 DME Board Set
- MKS-2440 Frame Memory Board Set
- MKS-2420M Color Corrector Board
- BZS-2000M Switcher Upgrade Software
- BZS-2470M DME Upgrade Software
- BZS-2440M Frame Memory Upgrade Software
- HK-PSU02 Power Supply Unit (for MFS-2000)
- HK-PSU11 Power Supply Unit (for control panels)

*For more information about the above options, refer to the MFS-2000-C Operation Manual supplied with the MFS-2000 Multi Format Switcher Processor.*

- MKS-2700 Device Control Unit
- MKS-8700 Device Control Unit

*For more information about the above options, refer to the DCU-2000 or DCU-8000 Operation Manual supplied with the DCU-2000 or DCU-8000 Device Control Unit Pack.*

- MKS-2050 Editing Keyboard
- MKS-8050 Editing Keyboard
- BZS-8050 Editing Control Software

*For more information about the above options, refer to the MKS-2050/8050 Operation Manual supplied with the MKS-2050/8050 Editing Keyboard and the BZS-8050 User's Guide.*

- MKS-8080 AUX Bus Remote Panel
- MKS-8082 AUX Bus Remote Panel

*For more information about the above options, refer to the MKS-8080/8082 Operation Guide or Operation Manual supplied with the MKS-8080/8082 AUX Bus Remote Panel.*

*Note that the MKS-8080/8082 Operation Manual is supplied as a PDF file unlike the MKS-8080/8082 Operation Guide. For more information about the MKS-8080/8082 Operation Manual, contact the Sony dealer from whom you purchased the MKS-8080/8082.*

---

## **Control Panel Types**

In this system, you can use any one of the three control panels shown on the following page. This manual refers to these control panels by the names shown in parentheses ( ) in the figure on that page.

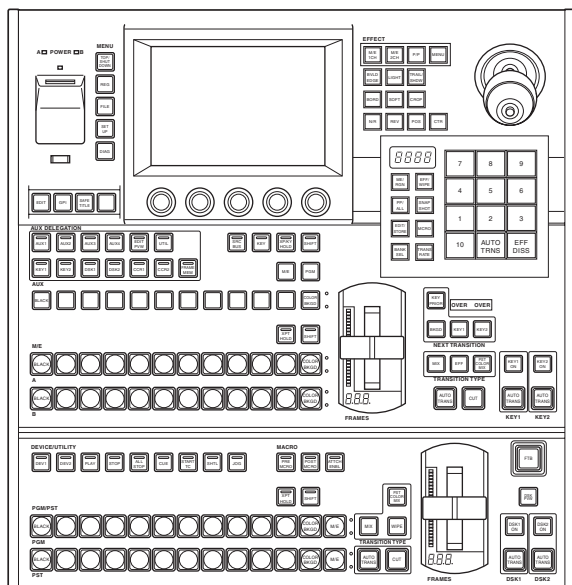

MKS-2015 Control Panel (1.5 M/E panel)

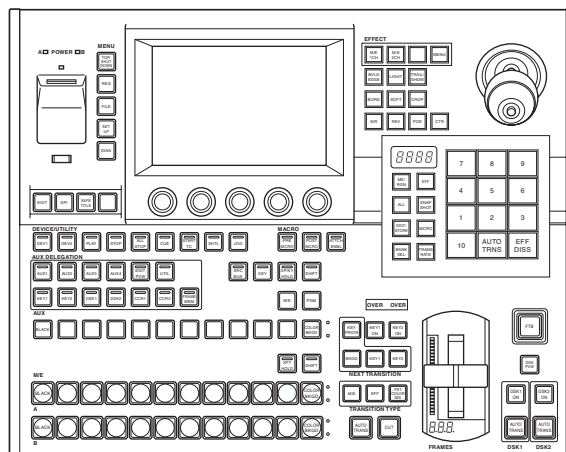

MKS-2010 Control Panel (1 M/E panel)

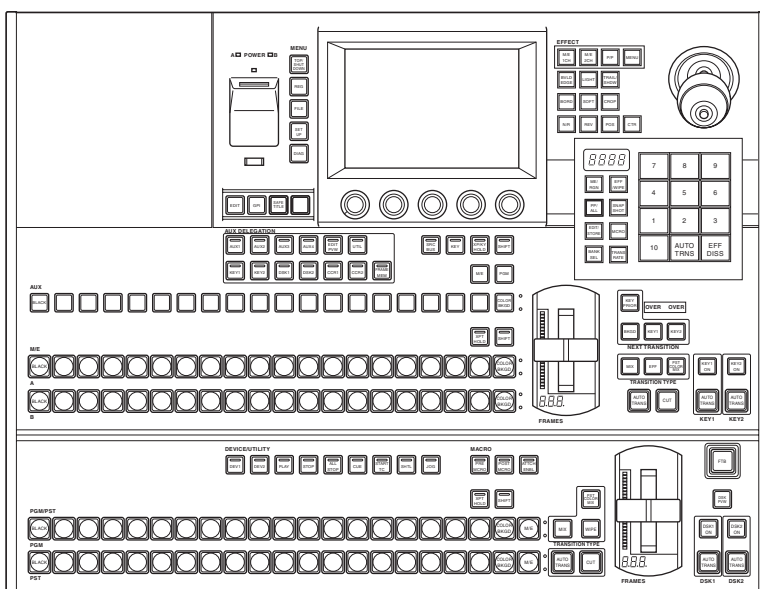

MKS-2017 Wide Control Panel (1.5 M/E wide panel)

### Principal differences

The principal differences between the three control panels are as follows.

Control panel	PGM/PST cross-point control block, PGM/PST transition control block	Number of cross-point buttons
1 M/E panel	No	12 per row
1.5 M/E panel	Yes	12 per row <sup>a)</sup>
1.5 M/E wide panel	Yes	20 per row <sup>a)</sup>

a) The 1.5 M/E panel and the 1.5 M/E wide panel differ in the number of cross-point buttons. They are identical in all other respects.

### Operation button positions

The positions of some operation buttons on the 1 M/E panel are different from the positions of the buttons with the same functions on the 1.5 M/E panel and 1.5 M/E wide panel. This manual explains how to operate using the 1.5 M/E panel, but figures are also provided for the 1 M/E panel when the buttons employed are in different positions.

# Control Panel Configuration

## 1.5 M/E panel and 1.5 M/E wide panel

The sole difference between these control panels is the number of cross-point buttons per row. Most of the illustrations in this manual show the configuration of the 1.5 M/E panel.

See the pages in parentheses ( ) for the functions of the illustrated parts.

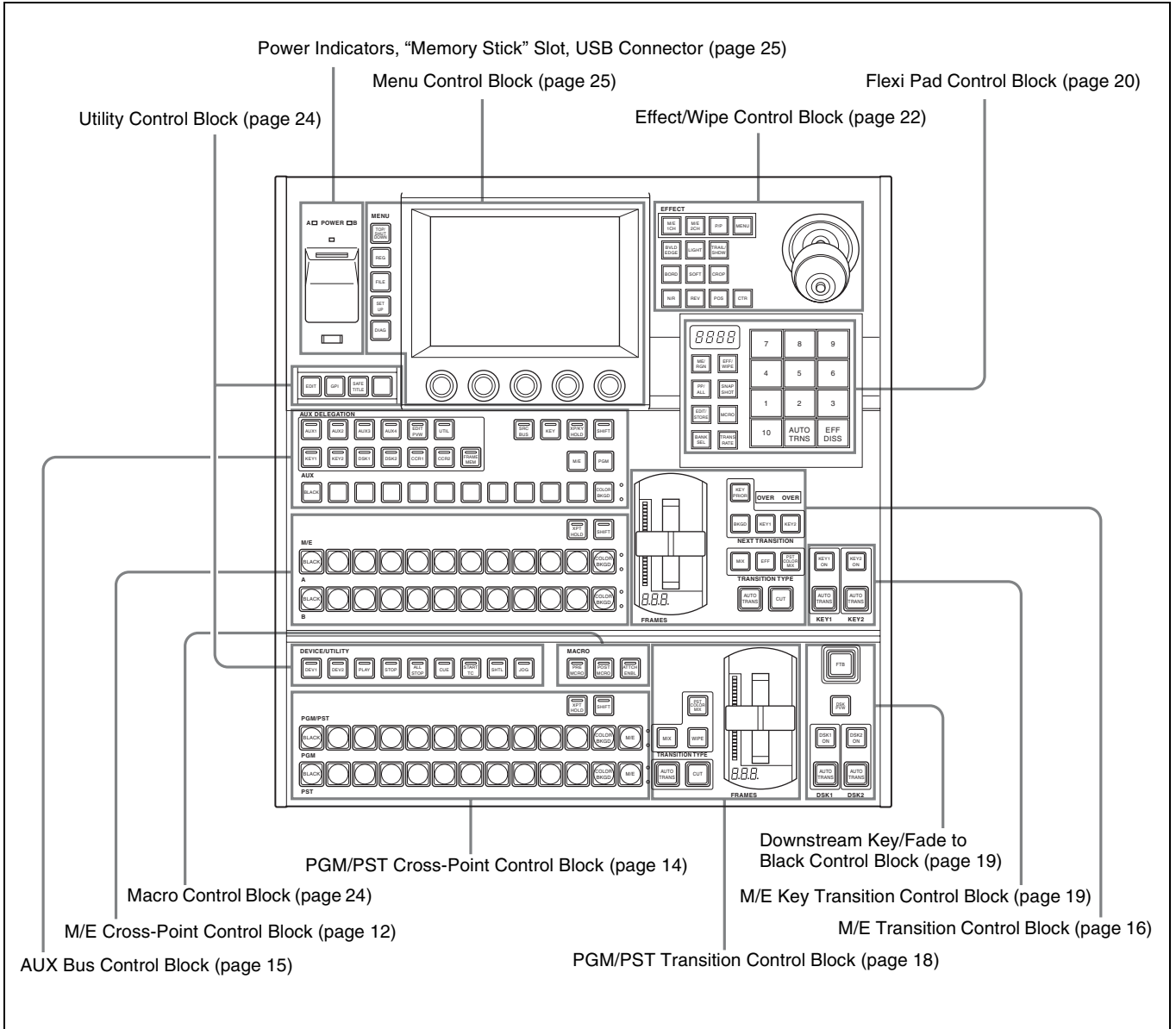

## 1 M/E panel

See the pages in parentheses ( ) for the functions of the illustrated parts.

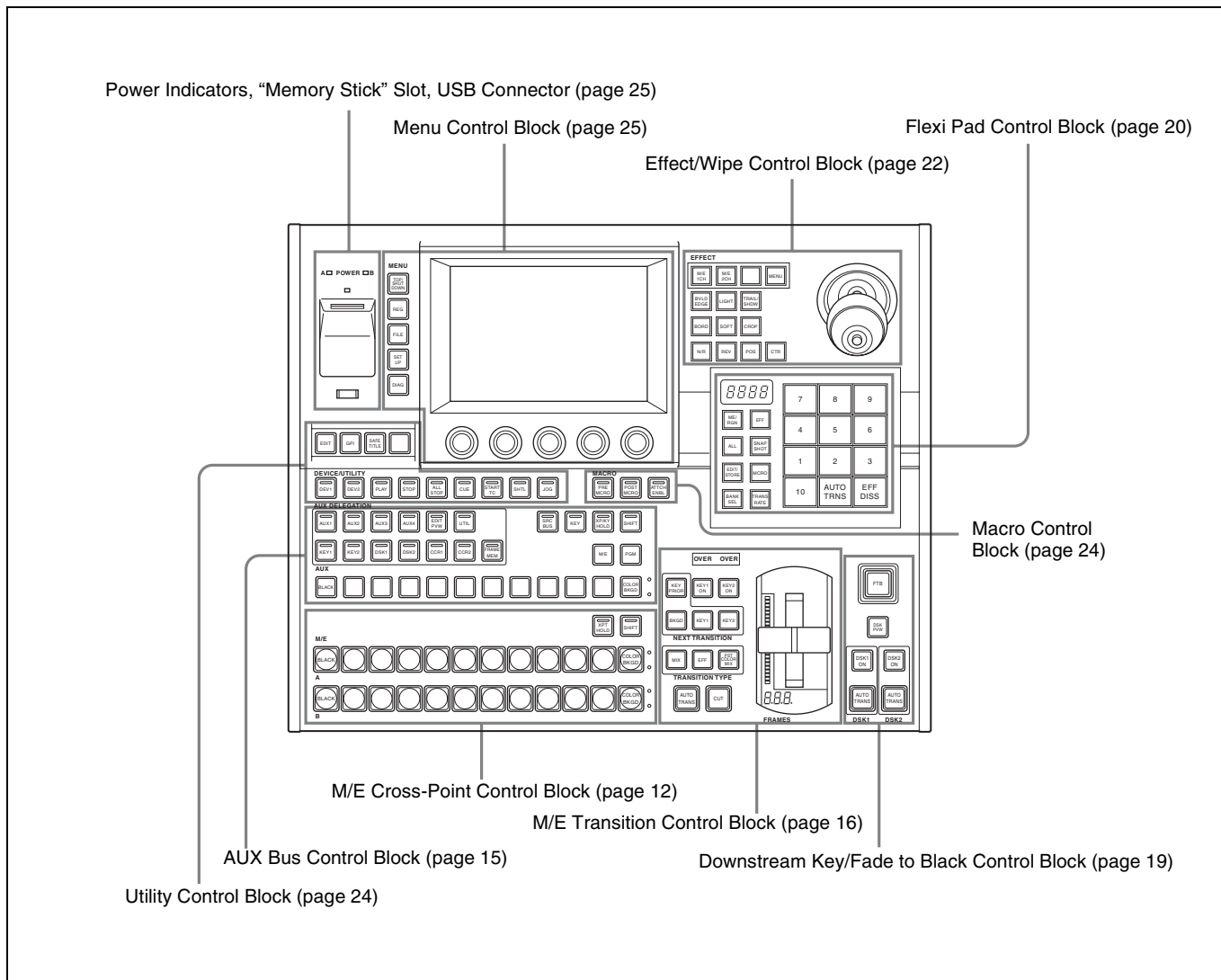

### M/E Cross-Point Control Block

Use the M/E (mix/effect) cross-point control block to select the video signals to be used as the video background.

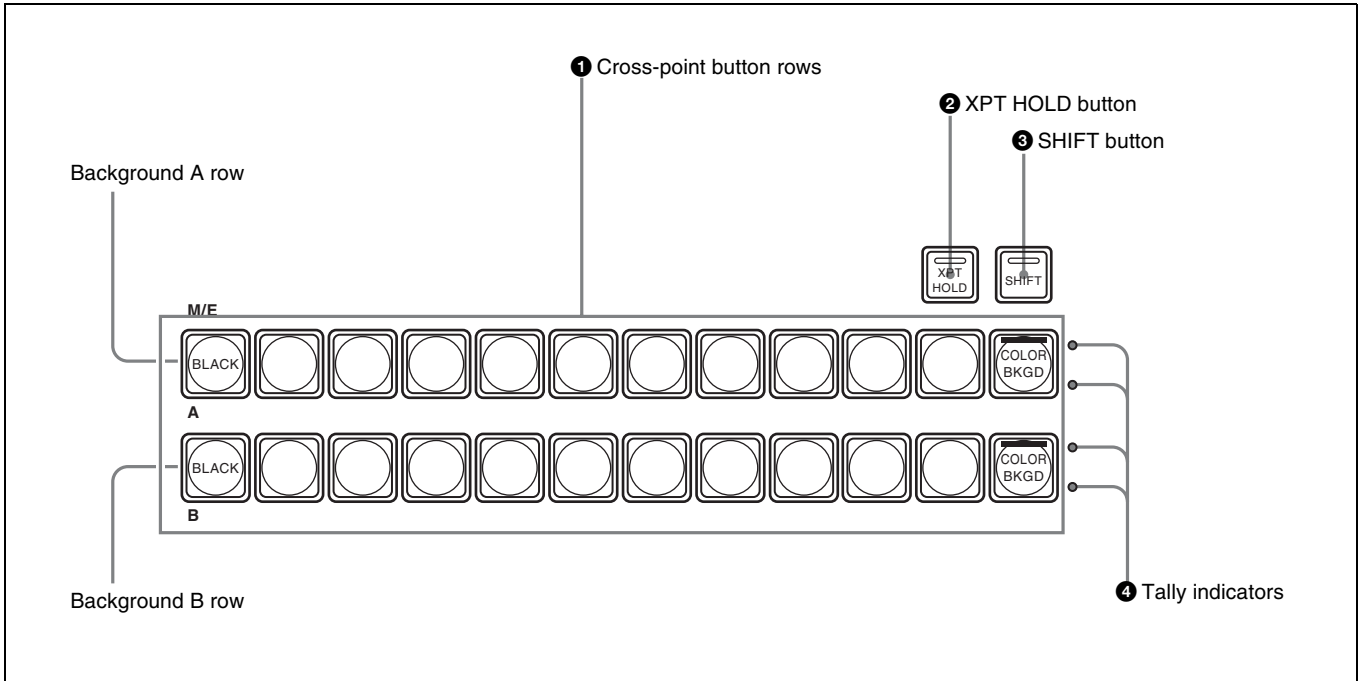

### 1 Cross-point button rows

Select background video by pressing the corresponding button.

The buttons in the background A row select the background video which is output before the start of a transition (A bus video). Pressing a button selects the signal assigned to that button (input signals to the IN1 to IN16 connectors <sup>1)</sup> of the processor, or signals which the processor generates internally). The button lights in red (high tally) if the selected signal is being output to the program video (final output video). Otherwise it lights in amber (low tally).

1) The MKS-2110M Input/Output Connector Board must be installed to use the IN9 to IN16 connectors.

The buttons in the background B row select the background video which is output after a transition (B bus video). The button lights in red (high tally) if the selected signal is being output to the program video. It lights in amber (low tally) if the selected signal is not being output to the program video.

In addition to the operating mode described above (flip-flop mode), you can also select bus fixed mode. In bus fixed mode, the signal selected on the background A row is always output when the fader lever is at the top, and the signal selected on the background B row is always output when the fader lever is at the bottom.

*For more information about bus fixed mode, see “Setting the Bus Toggle On or Off” (page 223).*

The buttons in the A row and the B row select the same signals. For example, the fifth button from left in the A row

selects the same signal as the fifth button from left in the B row.

You can use the Xpt Assign menu to freely change the assignment of signals to cross-point buttons.

*For details, see “Assigning Signals to Cross-Point Buttons (Operation Menu)” (page 204).*

### Cross-point button numbers

On the 1 M/E panel and the 1.5 M/E panel, there are 12 cross-point buttons in each row. On the 1.5 M/E wide panel, there are 20 cross-point buttons in each row. These buttons are numbered 1 to 12 or 1 to 20 from the left side of the panel. Pressing the [SHIFT] button 3 to turn the shift function on makes more cross-point button numbers available: numbers 13 to 24, or 21 to 40. This manual refers to the buttons available when the shift function is on as “shift side buttons”, and to the buttons available when the shift function is off as “non-shift side buttons”.

*See page 204 for more information about cross-point button numbers.*

### 2 XPT (cross-point) HOLD button

By pressing this button to turn it on (it lights in amber), you can recall a snapshot or recall timeline data to execute a timeline effect while retaining the current cross-point selection state. (The cross-point selection information in the snapshot is ignored.)

### 3 SHIFT button

This button has the following three operation modes.

**Hold:** While this button is held down, the shift side buttons are enabled.

**Lock:** Pressing this button toggles it on and off. When the button is on, the shift side buttons are enabled.

**Off:** No effect.

On how to select the modes, see “To set the cross-point button shift operation” (page 206).

#### Note

This button does not light and does not function when you are using the rightmost buttons in the cross-point button rows (the 12th or 20th buttons) as [SHIFT] button.

For more information about operations to use the rightmost buttons as [SHIFT] buttons, see “To use the rightmost buttons in cross-point button rows as [SHIFT] buttons (shift mode selection)” (page 206).

#### 4 Tally indicators

Currently not used.

## PGM/PST Cross-Point Control Block

Use the PGM/PST (program/preset) cross-point control block to select the video signals to be used as the background in program video (final output video).

This control block is found only on the 1.5 M/E and 1.5 M/E wide panels.

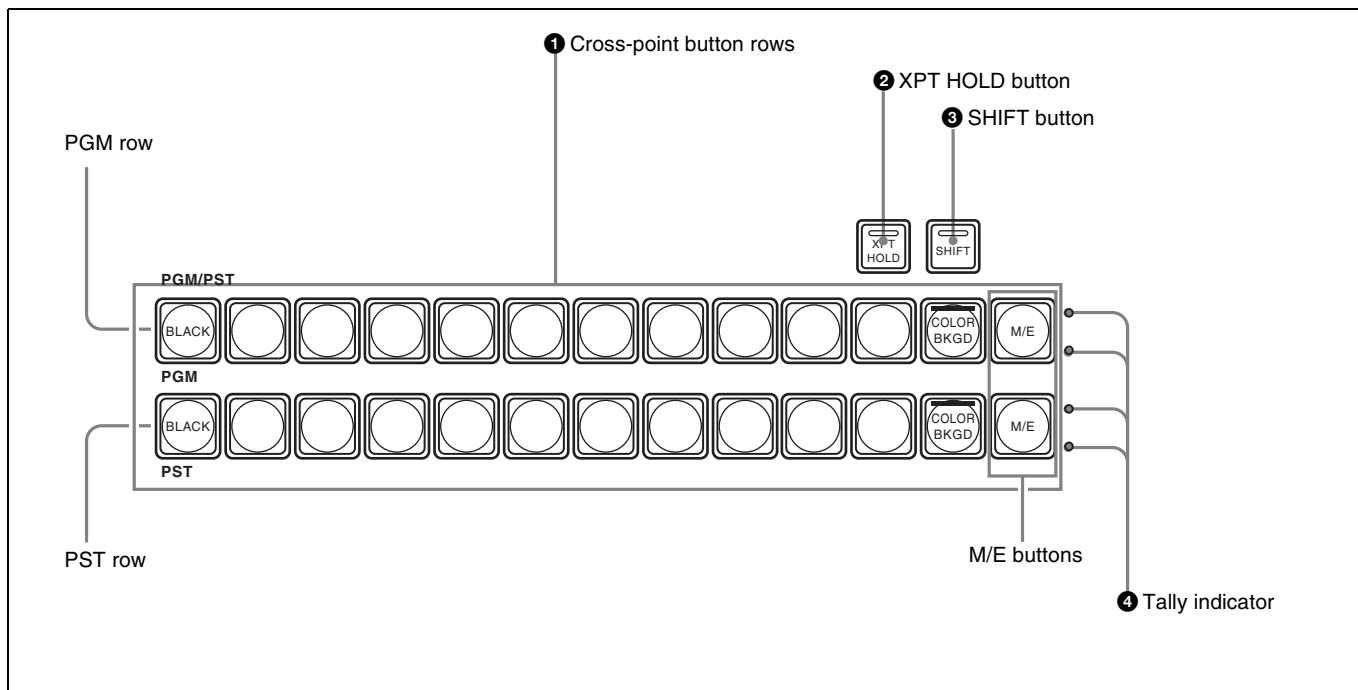

#### 1 Cross-point button rows

The buttons in the PGM (program) row select the background video which is output before the start of a transition. The buttons in the PST (preset) row select the background video after the end of a transition.

The signals selectable with the cross-point buttons are the same as the signals selectable with the corresponding buttons in the M/E cross-point control block (see page 12). The meaning of the colors in which buttons light and the button numbers are also the same as with the M/E cross-point control block. The [M/E] buttons at the right edge of each cross-point button row are reentry buttons. They allow you to import video created in the M/E block and use it as background video in the PGM/PST block.

#### 2 XPT (cross-point) HOLD button

By pressing this button to turn it on (it lights in amber), you can recall a snapshot or recall timeline data to execute a timeline effect while retaining the current cross-point selection state. (The cross-point selection information in the snapshot is ignored.)

#### 3 SHIFT button

This button has the following three operation modes.

**Hold:** While this button is held down, the shift side buttons are enabled.

**Lock:** Pressing this button toggles it on and off. When the button is on, the shift side buttons are enabled.

**Off:** No effect.

On how to select the modes, see “To set the cross-point button shift operation” (page 206).

**Note**

This button does not light and does not function when you are using the rightmost buttons in the cross-point button rows (the 12th or 20th buttons) as [SHIFT] button.

For more information about operations to use the rightmost buttons as [SHIFT] buttons, see “To use the rightmost buttons in cross-point button rows as [SHIFT] buttons (shift mode selection)” (page 206).

**4 Tally indicator**

Currently not used.

## AUX Bus Control Block

Use this block to select key signals and to select the signals to which a variety of functions are applied.

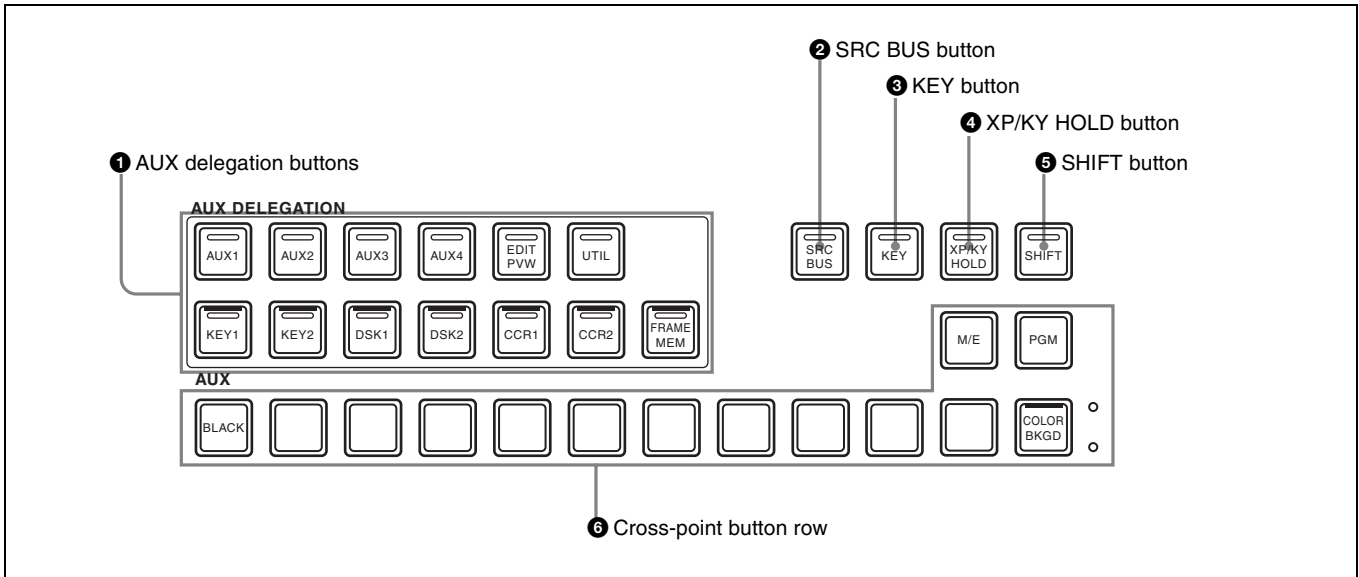
**1 AUX delegation buttons**

By pressing one of the following buttons, lighting it, you select the bus to which the cross-point button row **6** is assigned. Signals selected in the cross-point button row are output to the bus selected here.

The buses selectable by the various buttons are as follows.

**AUX1 to 4:** AUX1 to AUX4 buses

**EDIT PVW:** EDIT PVW (edit preview) bus

**UTIL:** Utility bus

**KEY1:** Key1 bus or Key1 Source bus. (The state of the [SRC BUS] button **2** determines which of the two buses is selected.)

**KEY2:** Key2 bus or Key2 Source bus. (The state of the [SRC BUS] button **2** determines which of the two buses is selected.)

**DSK1:** DSK1 (downstream key 1) bus or DSK1 Source (downstream key 1 source) bus. (The state of the [SRC BUS] button **2** determines which of the two buses is selected.)

**DSK2:** DSK2 (downstream key 2) bus or DSK2 Source (downstream key 2 source) bus. (The state of the [SRC BUS] button **2** determines which of the two buses is selected.)

**CCR1 and CCR2:** CCR1 (color correction 1) or CCR2 bus

**FRAME MEM:** Frame Memory Video bus, or Frame Memory Key bus. (The state of the [SRC BUS] button **2** determines which of the two buses is selected.)

The button lights in red (high tally) if signals on the selected bus are being output to the program video (final output video). Otherwise it lights in amber (low tally).

Buttons which target two buses ([KEY1], [KEY2], [DSK1], [DSK2], and [FRAME MEM]) light in red if signals on either of the buses are being output to program video.

**2 SRC (source) BUS button**

When an AUX delegation button which targets two buses ([KEY1], [KEY2], [DSK1], [DSK2], and [FRAME MEM]) is turned on, the bus which is actually selected is determined by whether this button is on (lit) or off (not lit).

AUX delegation button	SRC BUS button off	SRC BUS button on
KEY1	Key1 bus	Key1 Source bus
KEY2	Key2 bus	Key2 Source bus
DSK1	DSK1 bus	DSK1 Source bus
DSK2	DSK2 bus	DSK2 Source bus

AUX delegation button	SRC BUS button off	SRC BUS button on
FRAME MEM	Frame Memory Video bus	Frame Memory Key bus

### ③ KEY button

In the following cases, you can select the key signal in the cross-point button row by pressing this button to turn it on.

- When the AUX delegation button [AUX1], [AUX2], [AUX3] or [AUX4] is lit.
- When the AUX delegation button [KEY1], [KEY2], [DSK1], [DSK2], or [FRAME MEM] is lit with the [SRS BUS] button being on.

### ④ XP/KY (cross-point/key) HOLD button

By pressing this button to turn it on (it lights in amber), you can recall a snapshot or recall timeline data to execute a timeline effect while retaining the current cross-point selection state (cross-point hold), for buses other than key buses.

For key buses, you can select any of the following three options.

- Cross-point hold (retain the current cross-point selection state)
- Key disable (retain the current key settings)
- Key disable, plus retention of the current key on/off states

See “Setting the key bus cross-point hold mode” (page 222) for more information about how to set the operating mode.

### ⑤ SHIFT button

This button has the following three operation modes.

**Hold:** While this button is held down, the shift side buttons are enabled.

**Lock:** Pressing this button toggles it on and off. When the button is on, the shift side buttons are enabled.

**Off:** No effect.

On how to select the modes, see “To set the cross-point button shift operation” (page 206).

### ⑥ Cross-point button row

These buttons select the signals to be output to the bus selected with the AUX delegation buttons.

The signals which can be selected with each cross-point button are the same as the signals selected by the corresponding buttons in the M/E cross-point control block (see page 12). Button numbers and the meaning of the colors in which the buttons light are the same as those of the buttons in the M/E cross-point control block.

However, the cross-point button row in the AUX bus control block contains an [M/E] button and a [PGM] button, which are not present in the M/E cross-point button rows. The [M/E] button selects the M/E program video, and the [PGM] button selects the program video (final output video).

## M/E Transition Control Block

Use this block to control transitions in M/E (mix/effect) program video.

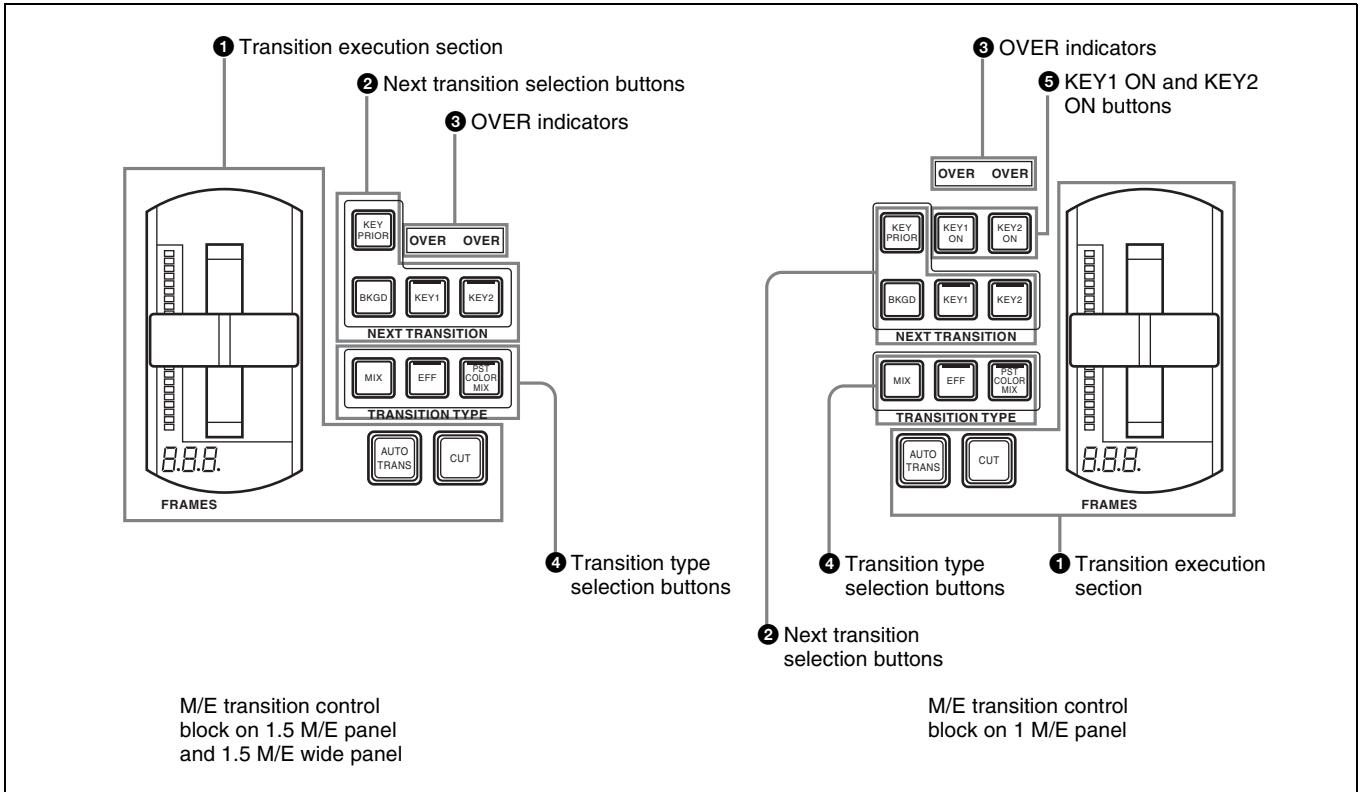

### 1 Transition execution section

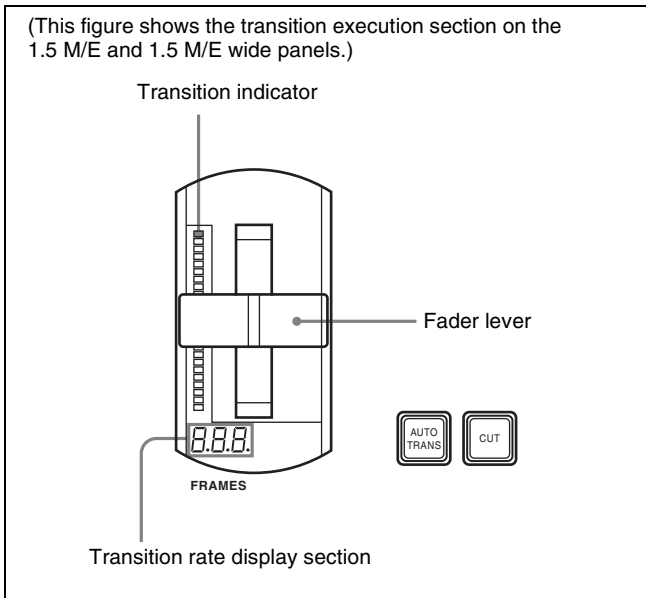

**Fader lever:** Move the lever up and down to execute the transition.

You can also use this to execute a timeline effect. In this case, it is necessary first to assign the function for switching between transition and timeline effect execution to the PST COLOR MIX button.

**Transition indicator:** Displays the progress of the transition with 24 LEDs. The number of lit LEDs increases as the transition proceeds.

**Transition rate display section:** Displays the specified transition rate (the time from the start to the end of the transition, in units of frames).

See “Setting Transition Rates” (page 76) for more information about how to specify transition rates.

**AUTO TRANS (transition) button:** Press to execute a transition automatically at the specified transition rate. The transition begins immediately, and the button lights in amber. The button goes out when the transition finishes.

**CUT button:** Press to execute an instant transition.

### 2 Next transition selection buttons

To specify which part of the video to switch (change) in the next transition, press one of the following buttons, turning it on.

**BKGD (background):** Switches the background video in the next transition.

**KEY1, KEY2:** Press the [KEY1] button, turning it on, to insert key 1 into the background in the next transition, or to delete it from the background. If key 1 is not currently inserted, the transition inserts it. If key 1 is currently inserted, the transition deletes it. The [KEY2] button works in the same way.

**KEY PRIOR (priority):** When key 1 and key 2 are inserted in an overlapping state, the key on top appears in front on the monitor. By pressing this button, turning it on, you can reverse the priority of the two keys in the next transition.

### ③ OVER indicators

When key 1 and key 2 are inserted, the OVER indicator for the key on top lights.

### ④ Transition type selection buttons

To select the type of transition, press one of the following buttons, turning it on.

**MIX:** In a background transition, the new video overlaps the current video, finally replacing it. During the transition, the sum of the output levels of the A bus and the B bus is maintained at 100%.

In a key transition, the key fades in (for insertion) or out (for removal).

**EFF (effect):** A transition using the selected effect pattern is executed.

See “Selecting Effects” (page 63) for more information about how to select effects.

**PST (preset) COLOR MIX :** This is a two-stage mix (dissolve), comprising two transitions. In the first transition, a color matte is gradually mixed into the current video. In the second transition, the new video is gradually mixed into the color matte. You can perform both of these operations in a single transition.

For details, see “Setting a Preset Color Mix” (page 223).

The [EFF] button and the [PST COLOR MIX] button can be assigned with clip transitions (see page 149).

For details of the method of assignment, see “Changing the function of the transition type selection button in the transition control block” (page 226).

When using the fader lever to execute a timeline effect, you can also assign the function for switching between transition and timeline effect execution to the [EFF] button or the [PST COLOR MIX] button.

### ⑤ KEY1 ON and KEY2 ON buttons

Press the corresponding button to instantly insert or delete key 1 or key 2. The [KEY1 ON] button lights in red when key 1 is inserted into the program video (final output video). Otherwise it lights in amber. The [KEY2 ON] button works in the same way.

## PGM/PST Transition Control Block

Use this block to control program transitions. This control block is provided only on the 1.5 M/E and 1.5 M/E wide panels.

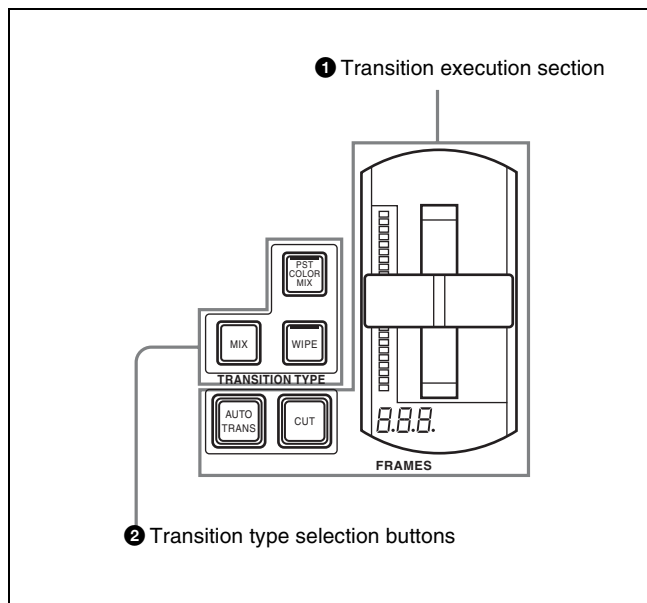

### ① Transition execution section

This works in the same way as the transition execution section in the M/E transition control block (see page 16).

### ② Transition type selection buttons

To select the type of transition, press one of the following buttons, turning it on.

**MIX:** In a background transition, the new video overlaps the current video, finally replacing it. During the transition, the sum of the output levels of the PGM bus and the PST bus is maintained at 100%.

**WIPE:** A transition using the selected wipe pattern is executed, so that the new video wipes away the current video.

On how to select a wipe pattern, see “Selecting Effects” (page 63).

**PST (preset) COLOR MIX:** In the first transition, a color matte is gradually mixed into the current video. In the second transition, the new video is gradually mixed into the color matte. You can perform both of these operations in a single transition.

For details, see “Setting a Preset Color Mix” (page 223).

The [EFF] button and the [PST COLOR MIX] button can be assigned with clip transitions (see page 149).

For details of the method of assignment, see “Changing the function of the transition type selection button in the transition control block” (page 226).

When using the fader lever to execute a timeline effect, you can also assign the function for switching between transition and timeline effect execution to the [EFF] button or the [PST COLOR MIX] button.

## M/E Key Transition Control Block

Use this block to insert and delete keys in independent M/E background video transitions. The transitions are independent of the transitions performed with the M/E transition control block (see page 16).

This control block is provided only on the 1.5 M/E and 1.5 M/E wide panels. However, of the four buttons, the [KEY1 ON] and [KEY2 ON] buttons are also found on the 1 M/E panel, where they are located in the M/E transition control block (see page 16).

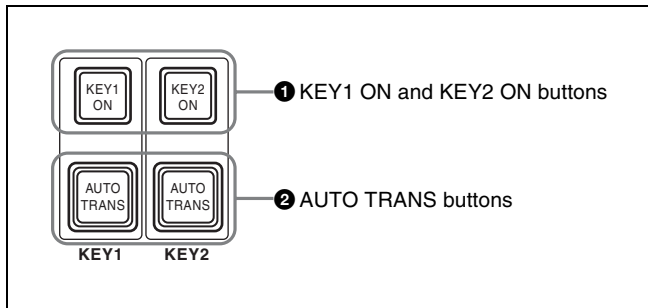

### 1 KEY1 ON and KEY2 ON buttons

Press the corresponding button to instantly insert or delete key 1 or key 2. The [KEY1 ON] button lights in red when key 1 is inserted into the program video (final output video). Otherwise it lights in amber. The [KEY2 ON] button works in the same way.

### 2 AUTO TRANS (transition) buttons

Press the corresponding button to insert or delete key 1 or key 2 at the specified transition rate. The key fades in (insert) or fades out (delete). The transition begins as soon as the button is pressed, and the button lights in amber. The button goes out when the transition finishes.

See “Setting Transition Rates” (page 76) for more information about how to specify transition rates.

## Downstream Key/Fade to Black Control Block

Use this block to insert and delete downstream keys, and to fade to black.

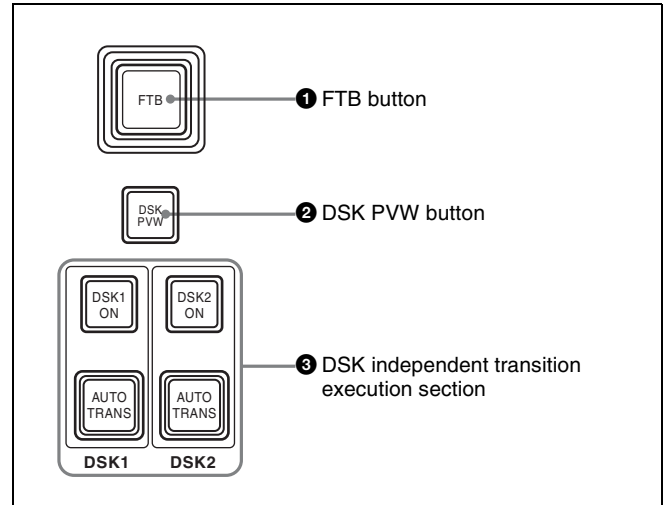

### 1 FTB (fade to black) button

Press this button to execute a fade to black at the specified transition rate. The button lights in amber when pressed. It lights in red when the fade to black is completed, for as long as black is output.

See “Setting Transition Rates” (page 76) for more information about how to specify transition rates.

### 2 DSK PVW (downstream key preview) button

You can press this button, turning it on, to temporarily switch M/E PVW output (1 M/E panel) or PST output (1.5 M/E panel) to DSK PVW output.

#### Note

Whether or not this switching function is available depends on a setting made in the Output Assign menu. For details, see “Switching M/E PVW or PST output to DSK PVW output” (page 204).

### 3 DSK independent transition execution section

**DSK1 ON, DSK2 ON buttons:** Press the [DSK1 ON] button to cut downstream key 1 in or out (insert or delete it instantly). The button lights in red when the key is inserted in program video (final output video). Otherwise it lights in amber. The [DSK2 ON] button works in the same way.

**AUTO TRANS buttons:** Press the corresponding button to insert or delete downstream key 1 or 2 at the specified transition rate. The key is mixed to fade in (insert) or out (delete). The transition begins as soon as the button is pressed, and the button lights in amber. When the transition finishes, the button goes out.

See “Setting Transition Rates” (page 76) for more information about how to specify transition rates.

## Flexi Pad Control Block

Use the Flexi Pad control block in the following operation modes.

- Effect snapshot mode
- Snapshot mode
- Macro mode
- Transition rate input mode
- Timeline mode
- Device control mode
- Independent key transition mode

Depending on the operation mode, this control block allows you to do the following.

### In effect snapshot mode:

- Recall, save, and delete effect snapshots
- Recall effect pattern numbers

### In snapshot mode:

- Recall, save, and delete snapshots
- Set snapshot attributes

### In macro mode:

Recall (execute), save, delete, and edit macros

### In transition rate input mode:

Enter transition rates

### In timeline mode:

- Recall, save, or delete timeline data
- Create and edit timeline data
- Execute timeline effects

### In device control mode:

VTR/disk recorder/extended VTR operations

### In independent key transition mode:

- Change types of independent key transitions
- Recall effect pattern numbers for independent key transitions
- Enter transition rates
- Execute independent key transitions

For details about the operation mode assignment, see “Changing the assignment of mode selection buttons in the Flexi Pad control block” (page 225).

These operation modes can be switched with the mode selection buttons in this control block or the mode assigned buttons in the utility control block.

For details about the command assignment, see “Assigning utility commands” (page 218).

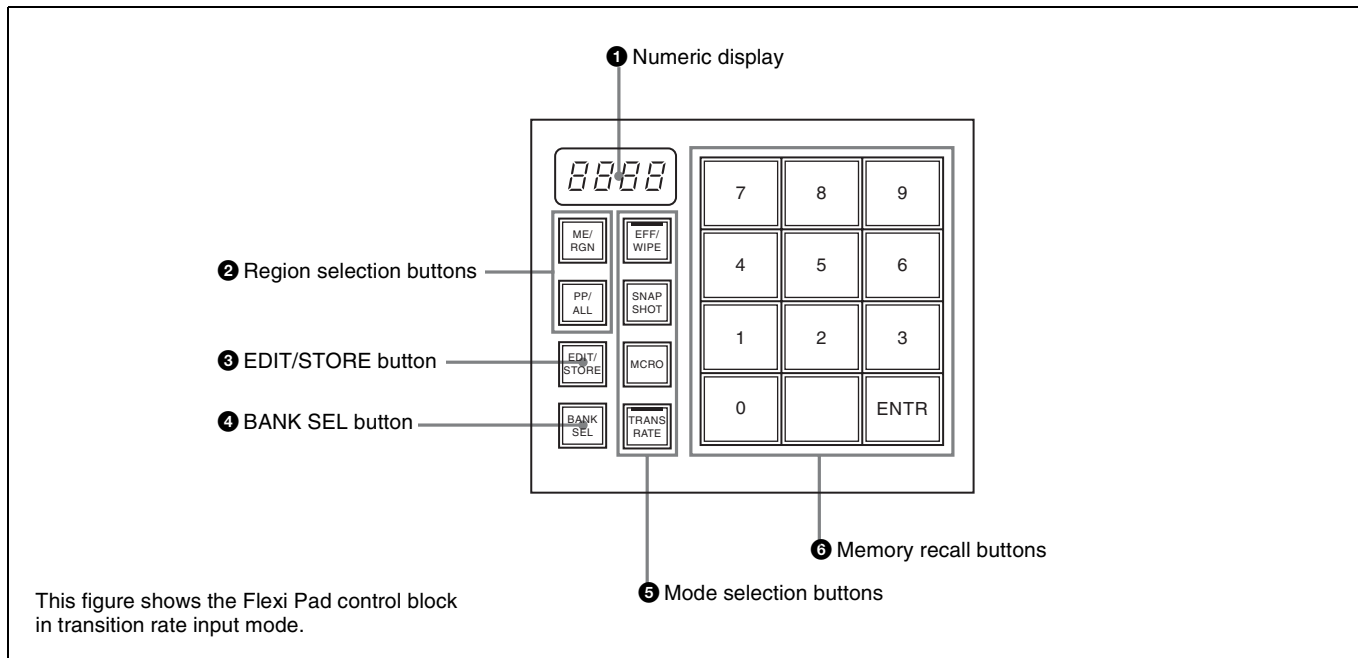

### 1 Numeric display

Depending on the operating mode, this shows the following numeric values of up to four digits.

**In effect snapshot mode:** Pattern number

**In snapshot mode:** Bank number and register number

**In transition rate input mode:** Transition rate

### In macro mode:

- In macro recall mode: A bank number and register number
- In macro edit mode: An event number and an event total
- In pause duration entry mode: A pause duration

**In timeline mode:**

- In modes other than editing operations: bank number and register number
- In editing operations mode: the current keyframe number and total number of keyframes

**In device control mode:** Blank**In independent key transition mode:** Effect pattern number**2 Region selection buttons**

Used in modes other than macro mode.

Select the target function block of the operation. The button which is on lights in amber.

When using a 1.5 M/E panel, these operate as the ME/RGN and PP/ALL buttons, as follows.

**In effect snapshot mode:** The ME/RGN button selects the M/E region, and the PP/ALL button selects the PGM/PST region.**In transition rate input mode:** The ME/RGN button selects the M/E region, and the PP/ALL button selects the PGM/PST region.**In snapshot mode:** The ME/RGN button selects the M/E region, and the PP/ALL button selects all regions.**In timeline mode:** The ME/RGN button switches to region selection mode. The PP/ALL button does not operate.

When using a 1 M/E panel, the ME/RGN button acts as an ALL button. The ME/RGN button has the same effect as above (when using a 1.5 M/E panel), and the ALL button acts as a button to select all regions in snapshot mode only.

**3 EDIT/STORE button**

This button lights in amber when on, to indicate that you can save the current snapshot or effect snapshot, enter macro edit mode or timeline edit mode, or delete a saved snapshot, effect snapshot, macro, or timeline.

**4 BANK SEL (selection) button**

Used in snapshot mode, macro mode, and timeline mode. Has no effect in other modes.

This button lights in amber when on, to indicate that you can use the memory recall buttons to specify a register bank.

**5 Mode selection buttons**

Select the operation mode of the Flexi Pad control block. The button currently turned on lights in amber.

By default the following operating modes are assigned, but you can also assign timeline mode, device control mode, or independent key transition mode to any of the buttons.

*For details about the operation mode assignment, see “Changing the assignment of mode selection buttons in the Flexi Pad control block” (page 225).***EFF/WIPE (effect snapshot):** Selects effect snapshot mode. You can also use this button when selecting effect patterns.**SNAPSHOT:** Selects snapshot mode.**MCRO (macro):** Selects macro mode. Lights in amber in macro recall mode, and lights in red in macro edit mode.**TRANS RATE:** Selects transition rate input mode.**6 Memory recall buttons**

The configuration of the memory recall buttons changes according to the operation mode selected with the mode selection buttons.

**In effect snapshot mode:** Comprised of the following buttons.

[0] to [9] buttons

[PTN NO. (pattern number)] button

[ENTR (enter)] button.

The state and functions of the [0] to [9] buttons and the [ENTR] button change depending on the state of the [PTN NO.] button and the [EDIT/STORE] button.

*For details, see “Selecting Effects With the Flexi Pad Control Block” (page 64).***In snapshot mode:** Comprised of the following buttons.

[0] to [9] buttons

[EFF DISS (effect dissolve)] button

[AUTO TRNS (transition)] button.

The state and functions of these buttons change depending on the state of the [BANK SEL] button and the [EDIT/STORE] button.

*For details, see “Saving Snapshots” (page 154).***In macro mode**

- In macro recall mode: Comprised of the following buttons.

[0] to [9] buttons

[Executed events/Total Events] button

[TAKE] button

The state and functions of the buttons change depending on the states of the [BANK SEL] and [EDIT/STORE] buttons.

- In macro edit mode: Comprised of the following buttons.

[INS (insert)] button

[MOD (modify)] button

[DEL (delete)] button

[PAUS (pause)] button

[ALL (select all)] button

[EXIT] button

[AUTO INS (auto insert)] button

[STOR/Register Number (store/register number)] button

[&lt;&lt; PREV (go to previous event)] button

[NEXT &gt;&gt; (go to next event)] button

- In pause time entry mode: Comprised of the following buttons.  
[0] to [9] buttons  
[CLR (clear)] button  
[PAUS/ENTR (pause/enter)] button

For details, see “Macros” (page 169).

- In transition rate input mode:** Comprised of the following buttons.  
[0] to [9] buttons  
[ENTR (enter)] button.

For details, see “Setting Transition Rates” (page 76).

- In timeline mode:** Comprised the following buttons.

[0] to [9] buttons  
[RUN] button  
[REWIND] button

The state and effect of each button depends on the state of the [BANK SEL] button, [EDIT/STORE] button, and [ME/RGN] button.

For details, see “Timeline Function” (page 159).

- In device control mode:** Comprised of the following buttons.

[SHTL (shuttle)] button  
[JOG] button  
[REC (record)] button

[SET START (set the current timecode as the start point)] button  
[SET STOP (set the current timecode as the stop point)] button  
[FM LOOP (frame memory loop)] button  
[STRT TC (enter start timecode)] button  
[STOP TC (enter stop timecode)] button  
[CUE (cue up)] button  
[PLAY (playback)] button  
[STOP] button  
[ALL STOP] button.

For details, see “Manual VTR/Disk Recorder/Extended VTR Operations” (page 195).

- In independent key transition mode:** Comprised of the following buttons.

[ME KEY1 (menu shortcut)] button  
[FILL xxxx (key fill signal name display)] button  
[SRC xxxx (source signal name display)] button  
[MIX] button  
[EFF (effect)] button  
[HALF TRANS (half transition)] button  
[KEY ON] button  
[AUTO TRNS (auto transition)] button  
[RATE (transition rate)] button  
[PTN NO. (pattern number)] button.

For details, see “Using the Flexi Pad Control Block for an Independent Key Transition” (page 125).

## Effect/Wipe Control Block

Use this block to set the direction of effects and wipes. You can also add modifiers as required.

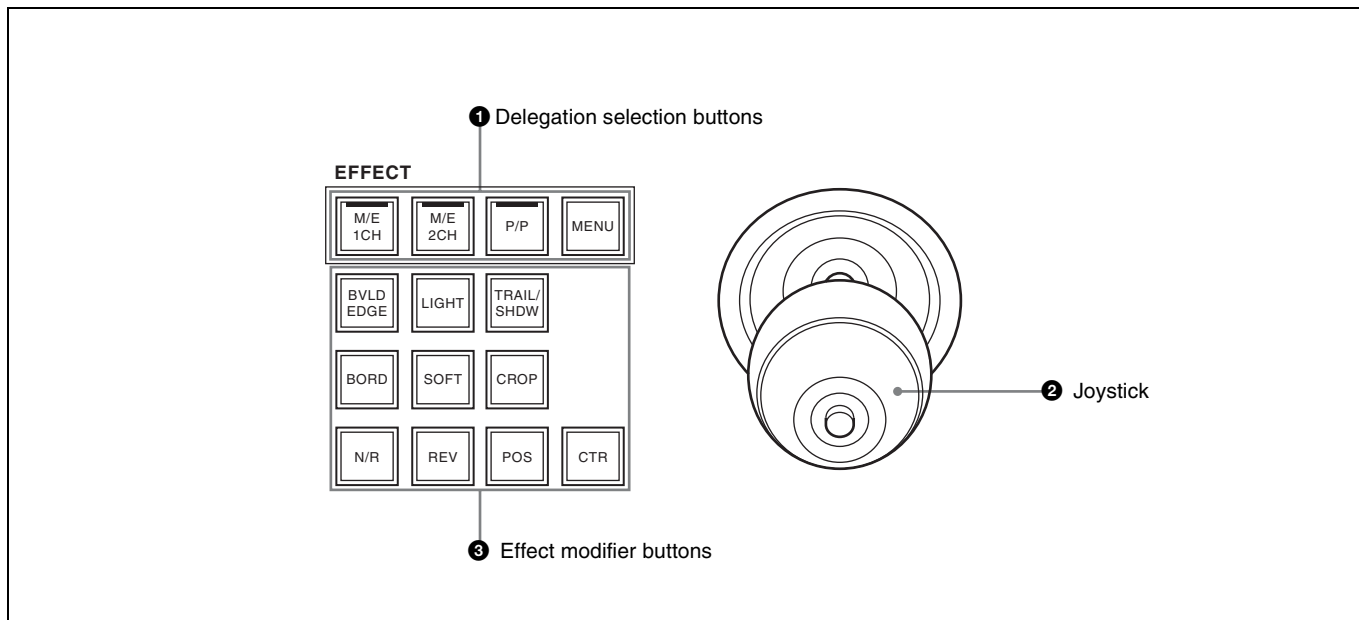

### ① Delegation selection buttons

Select operation targets.

**M/E 1CH (M/E1 channel), M/E 2CH (M/E2 channel)**

**buttons:** Select M/E1 channel or M/E2 channel or both as the operation target(s).

**P/P (PGM/PST) button (on 1.5 M/E panels only):**

Selects PGM/PST as the operation target.

**MENU button:** When this button is on, you can use the joystick to adjust the leftmost three parameters assigned to the knobs in the menu control block.

#### Notes

- The [M/E 2CH] button does not light and cannot be selected for effect patterns with numbers lower than 2000.
- When the [SHTL] button, [JOG] button, or a button in the utility control block to which [TL Run Control] is assigned is on, turning on a delegation selection button turns off that button. (The button pressed later receives priority).

### ② Joystick

The joystick has different effects in the following four cases.

**When one of the [M/E 1CH], [M/E 2CH], and [P/P] buttons is on**

You can use the joystick to adjust the position of the currently selected effect pattern. For some effect patterns, the joystick can be used to change their size.

**X-axis position:** The X value increases when the joystick is moved to the right, and decreases when the joystick is moved to the left.

**Y-axis position:** The Y value increases when the joystick is moved away from you, and decreases when the joystick is moved toward you.

**Size:** The value increases when the knob of the joystick is rotated clockwise, and decreases when it is rotated counterclockwise.

**When the [MENU] button is on**

You can use this to adjust parameters. Operation of the joystick is linked with operation of the knobs in the menu control block.

**Parameter assigned to knob 1:** The value increases when the joystick is moved to the right, and decreases when the joystick is moved to the left.

**Parameter assigned to knob 2:** The value increases when the joystick is moved away from you, and decreases when the joystick is moved toward you.

**Parameter assigned to knob 3:** The value increases when the knob of the joystick is rotated clockwise, and decreases when it is rotated counterclockwise.

The adjustment range depends on the parameter.

**When the [SHTL] button or [JOG] button in the utility control block is on**

The joystick can be used to control jog and shuttle mode search on devices or frame memory clips.

Move the joystick to the right for a forward direction search, and left for a reverse direction search.

**When a button in the utility control block already assigned to TL Run Control is lit**

You can use the joystick to execute a timeline effect.

Move the joystick to the right to execute in the forward direction, and left for the reverse direction.

**Fine adjustment with the joystick (fine mode)**

When changing the position or size of an effect pattern, menu operations, or timeline effect execution is assigned to the joystick, holding down the button in the top of the joystick while operating it reduces the degree of change caused by the operation, to allow finer control. For jog/shuttle operations there is no fine mode.

### ③ Effect modifier buttons

**BVLD (beveled) EDGE:** When this button is on, you can add beveled edges to the image. This button lights in green when beveled edge parameters are assigned to the knobs in the menu control block, and lights in amber when no beveled edge parameters are assigned to the knobs.

**LIGHT (lighting):** When this button is on, you can add a lighting effect to the image. This button lights in green when lighting parameters are assigned to the knobs in the menu control block, and lights in amber when no lighting parameters are assigned to the knobs.

**TRAIL/SHDW (shadow):** When this button is on, you can add a shadow to the image. This button lights in green when shadow parameters are assigned to the knobs in the menu control block, and lights in amber when no shadow parameters are assigned to the knobs.

**BORD (border):** When this button is on, you can add borders. The button lights in amber when no border parameters have been assigned to the knobs in the menu control block, and lights in green when they have been assigned.

**SOFT (soft edges):** When this button is on, you can add soft edges. The button lights in amber when no soft edge parameters have been assigned to the knobs in the menu control block, and lights in green when they have been assigned.

**CROP:** When this button is on, you can perform cropping. The button lights in amber when no crop parameters have been assigned to the knobs in the menu control block, and lights in green when they have been assigned.

**N/R (normal/reverse):** When this button is on, it lights in amber and the transition direction reverses every time a transition finishes.

**REV (reverse):** When this button is on, it lights in amber and the transition direction reverses.

**POS (positioner):** You can turn the positioner on and use the joystick to move effect patterns in the x-axis and y-axis directions, and to change their size.

**CTR (center):** When the [POS] button is on, pressing this button returns an effect pattern to the default position and size.

## Utility Control Block

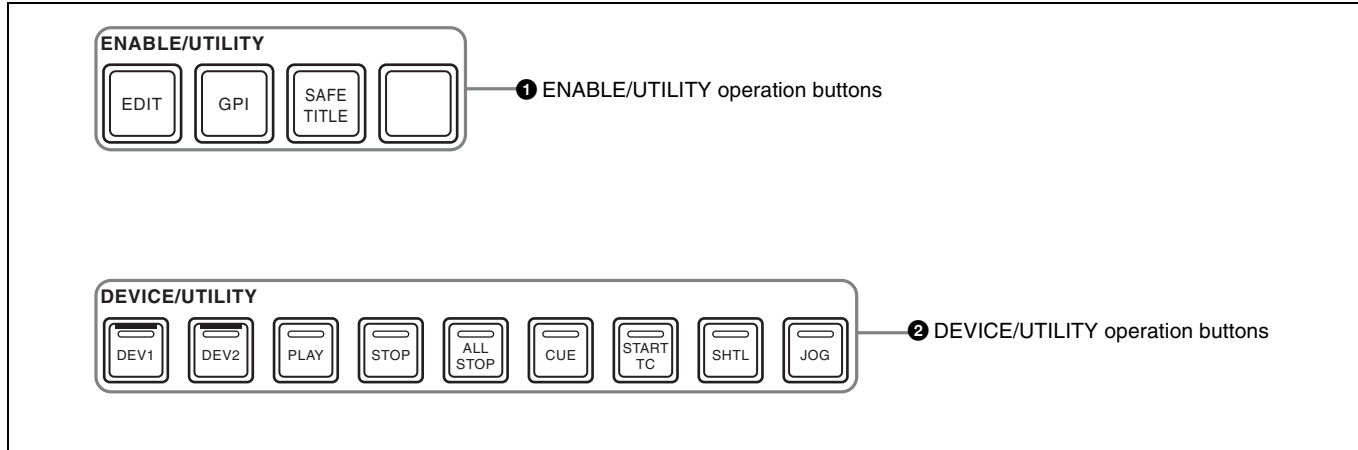

### 1 ENABLE/UTILITY operation buttons

You can assign utility commands to these buttons. The following utility commands are assigned by default.

**EDIT button:** Enables and disables the switcher edit mode.

**GPI button:** Enables and disables switcher GPI.

**SAFE TITLE button:** Turns on and off a marker showing the television reception safe area and a cross marker showing the center of the screen.

**Blank button:** No function assignment.

See “Utility Settings (Utility Menu)” (page 218) for more information about how to assign arbitrary utility commands to these buttons.

### 2 DEVICE/UTILITY operation buttons

You can assign utility commands to these buttons. The following utility commands are assigned by default.

**DEV1/DEV2:** Selects the Device1/Device2 as control target.

**PLAY:** Plays a tape or disk.

**STOP:** Stops a tape or disk.

**ALL STOP:** Stops tapes or disks on all devices.

**CUE:** Cues up.

**START TC:** Sets the current timecode as the start point.

**SHTL:** Turns shuttle mode on and off.

**JOG:** Turns jog mode on and off.

#### Note

When a delegation selection button is on, turning on the [SHTL] button, [JOG] button, or a button in the utility control block to which [TL Run Control] is assigned turns

off the delegation selection button. (The button pressed later receives priority).

See “Utility Settings (Utility Menu)” (page 218) for more information about how to assign arbitrary utility commands to these buttons.

## Macro Control Block

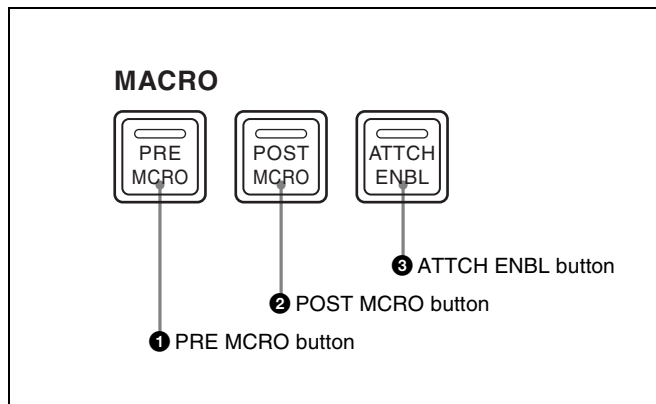

### 1 PRE MCRO button

Use this button to set a macro attachment in pre macro mode.

For setting in macro only mode, use this in combination with a Macro Only Set button assigned to the utility control block.

Alternatively, without using the Macro Only Set button, you can make the selection simply, by pressing this button simultaneously with the [POST MCRO] button.

## ❷ POST MCRO button

Use this button to set a macro attachment in post macro mode.

For setting in macro only mode, use this in combination with a Macro Only Set button assigned to the utility control block.

Alternatively, without using the Macro Only Set button, you can make the selection simply, by pressing this button simultaneously with the [PRE MCRO] button.

## ❸ ATTCH ENBL (attachment enable) button

When this button is on, macro attachments assigned to buttons on the control panel are enabled.

## Menu Control Block

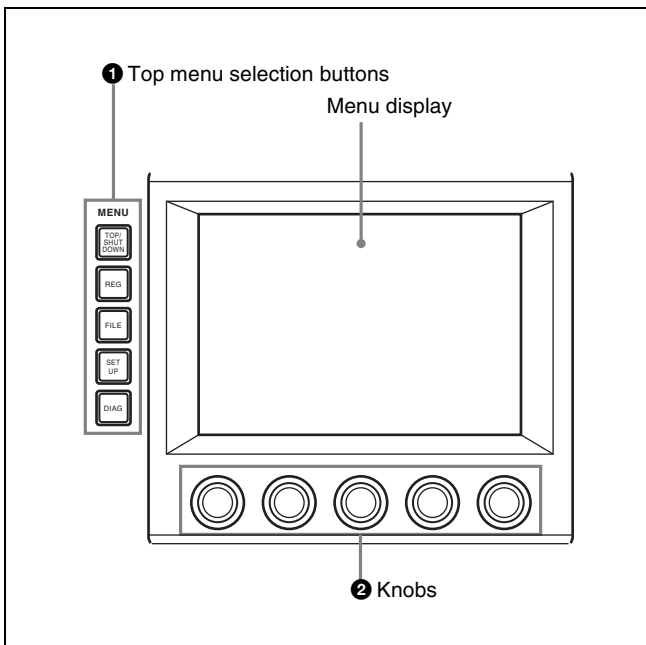

### ❶ Top menu selection buttons

Select the menu shown in the menu display.

- TOP/SHUTDOWN (top menu/shutdown) button
- REG (register menu) button
- FILE (file menu) button
- SET UP (setup menu) button
- DIAG (diagnostics menu) button

### ❷ Knobs

Use to adjust parameters shown in the menus.

## Power Indicators, “Memory Stick” Slot, USB Connector

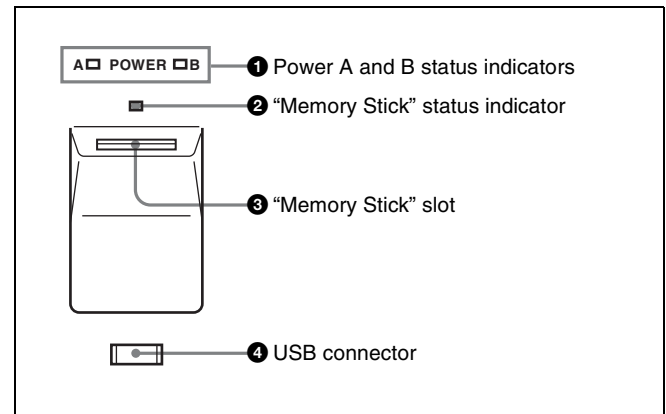

### ❶ Power A and B status indicators

Two power supplies (A and B) can be installed in the control panel. When the control panel is powered on, the indicators corresponding to the installed power supplies light in green.

Installing a second power supply requires the optional HK-PSU11 Power Supply Unit.

### ❷ “Memory Stick” status indicator

Lights in red during access to a “Memory Stick”.

### ❸ “Memory Stick” slot

Insert “Memory Stick”.

See ““Memory Stick”” (page 26) for more information about the usable “Memory Stick” and their handling.

### ❹ USB connector

Devices compatible with the USB 1.1 standard can be connected. However, it is not possible to connect a USB keyboard.

---

# “Memory Stick”

---

## Usable “Memory Stick”

This unit has been confirmed to operate with the following “Memory Stick” media, which have a capacity of 16 GB (gigabytes) or less.

However, operation with all “Memory Stick” media is not guaranteed.

- “Memory Stick”
- “Memory Stick PRO”
- “MagicGate Memory Stick”
- “Memory Stick Duo”
- “Memory Stick PRO Duo”
- “Memory Stick PRO-HG Duo”
- “MagicGate Memory Stick Duo”
- “Memory Stick Micro”

### Notes

- When using a “Memory Stick PRO”, high-rate data transfer using parallel interface is not supported.
- This system does not support the MagicGate function.
- When using a “Memory Stick Duo”, be sure to use it with a “Memory Stick Duo Adaptor” (MSAC-M2 or equivalent). If you insert a “Memory Stick Duo” without using the adaptor, there is the possibility that the stick cannot be removed, resulting in a serious accident.
- When using a “Memory Stick Micro”, be sure to use it with a “Memory Stick Micro Adaptor” (MSAC-MMDS or equivalent). If you insert a “Memory Stick Micro” without using the adaptor, there is the possibility that the stick cannot be removed, resulting in a serious accident.

---

## Handling “Memory Stick”

When using “Memory Stick”, pay attention to the following points.

- Do not touch the connector of the “Memory Stick” with anything, including your finger or metallic objects.
- Do not attach anything other than the supplied label to the “Memory Stick” labeling position.
- Attach the label so that it does not stick out beyond the labeling position.
- Carry and store the “Memory Stick” in its case.
- Do not strike, bend, or drop the “Memory Stick”.
- Do not disassemble or modify the “Memory Stick”.
- Do not allow the “Memory Stick” to get wet.
- Do not use or store the “Memory Stick” in a location that is:
  - Extremely hot, such as in a car parked in the sun
  - Under direct sunlight
  - Very humid or subject to corrosive substances

## Accessing Menus

The menus of this switcher enable you to make system settings and settings related to effects.

To access menus, you can use any of the following three methods.

- Access from the top menu (*see next section*)
- Access by double clicking (*see page 28*)
- Access by single clicking (*see page 31*)

### Accessing Menus From the Top Menu

By pressing a top menu selection button in the menu control block (*see page 25*), you can directly access the menu page for that button. The menus which can be accessed with top menu selection buttons are as follows.

#### Menus accessed with top menu selection buttons and their functions

Button	Menu	Function	Reference page
TOP/SHUTDOWN	Top/Shutdown	Display the top menu, and exit the menu system.	Page 47
REG	Register <sup>a)</sup>	Make register settings.	Page 115 Page 156 Page 169 Page 176
FILE	File <sup>a)</sup>	Make file settings.	Page 179
SET UP	Setup/Diagnosis <sup>a)</sup>	Make settings related to setup, and to display of error status and error logs.	Page 201
DIAG	Diagnosis	Display error status and error logs.	"Error Messages" in the Appendix (separate document)

a) The most recently used menu is displayed.

To access a menu from the top menu, proceed as follows.

**Note**

The menu illustrations in this manual may differ in appearance from the menus actually shown in the menu display of the control panel.

- 1 Press the [TOP/SHUTDOWN] button in the menu control block.

The top menu appears.

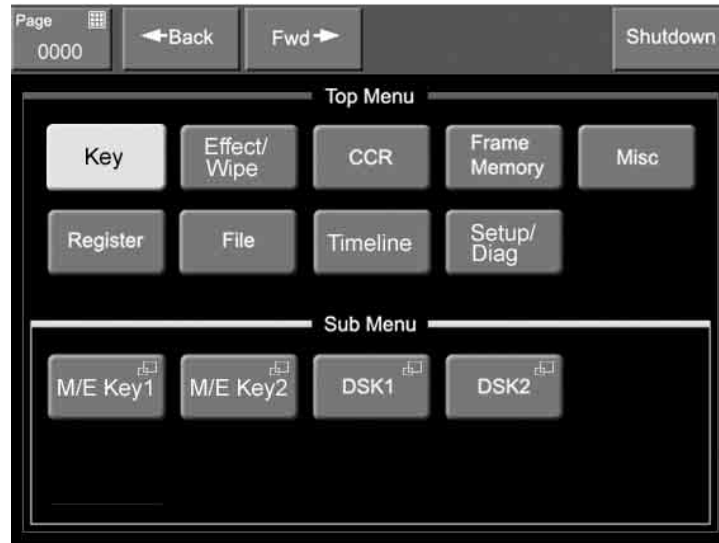
**Tip**

If you press the [REG], [FILE], [SET UP], or [DIAG] button, the page for that button appears.

- 2 In the Top Menu area, select a menu.

The second-level menu of the menu selected in the Top Menu area appears in the Sub Menu area.

- 3 Select a menu in the Sub Menu area.

If the menu has only two levels, the page for the second-level menu appears. If the menu has three levels, a popup window appears so that you can select a third-level menu.

- 4 Select a menu from the popup window.

The third-level menu appears.

---

## Accessing Menus by Double Clicking

This manual uses the term “double click” to refer to the action of pressing a button on the control panel twice in rapid succession (comparable to double clicking a computer mouse button). You can double click many of the buttons on the control panel except the top menu selection buttons to directly access menus related to those buttons. The following table shows the buttons which access menus by double clicking and the accessed menus.

**Tip**

The ability to access menus by double clicking is indicated by a horizontal bar on the face of the button, located over the button name.

**Menus accessed by double clicking**

<b>Button location</b>	<b>Button</b>	<b>Menu</b>	<b>Reference page</b>
M/E cross-point control block	COLOR BKGD <sup>a)</sup>	Misc >Color Bkgd	Page 95
	FM1 VIDEO <sup>a)</sup>	Frame Memory >Recall	Page 137
	FM1 KEY <sup>a)</sup>	Frame Memory >Recall	
	FM2 VIDEO <sup>a)</sup>	Frame Memory >Recall	
	FM2 KEY <sup>a)</sup>	Frame Memory >Recall	
	FM3 VIDEO <sup>a)</sup>	Frame Memory >Recall	
	FM3 KEY <sup>a)</sup>	Frame Memory >Recall	
	CCR1 <sup>a)</sup>	CCR >CCR1 >Primary	Page 128
	CCR2 <sup>a)</sup>	CCR >CCR2 >Primary	
PGM/PST cross-point control block <sup>b)</sup>	COLOR BKGD <sup>a)</sup>	Misc >Color Bkgd	Page 95
	FM1 VIDEO <sup>a)</sup>	Frame Memory >Recall	Page 137
	FM1 KEY <sup>a)</sup>	Frame Memory >Recall	
	FM2 VIDEO <sup>a)</sup>	Frame Memory >Recall	
	FM2 KEY <sup>a)</sup>	Frame Memory >Recall	
	FM3 VIDEO <sup>a)</sup>	Frame Memory >Recall	
	FM3 KEY <sup>a)</sup>	Frame Memory >Recall	
	CCR1 <sup>a)</sup>	CCR >CCR1 >Primary	Page 128
	CCR2 <sup>a)</sup>	CCR >CCR2 >Primary	
AUX bus control block (cross-point button rows)	COLOR BKGD <sup>a)</sup>	Misc >Color Bkgd	Page 95
	FM1 VIDEO <sup>a)</sup>	Frame Memory >Recall	Page 137
	FM1 KEY <sup>a)</sup>	Frame Memory >Recall	
	FM2 VIDEO <sup>a)</sup>	Frame Memory >Recall	
	FM2 KEY <sup>a)</sup>	Frame Memory >Recall	
	FM3 VIDEO <sup>a)</sup>	Frame Memory >Recall	
	FM3 KEY <sup>a)</sup>	Frame Memory >Recall	
	CCR1 <sup>a)</sup>	CCR >CCR1 >Primary	Page 128
	CCR2 <sup>a)</sup>	CCR >CCR2 >Primary	
AUX bus control block (AUX delegation buttons)	KEY1	Key >M/E Key1 >Main	Page 83
	KEY2	Key >M/E Key2 >Main	
	DSK1	Key >DSK1 >Main	
	DSK2	Key >DSK2 >Main	Page 128
	CCR1	CCR >CCR1 >Primary	
	CCR2	CCR >CCR2 >Primary	
	FRAME MEM	Frame Memory >Freeze	

Menus accessed by double clicking

Button location	Button	Menu	Reference page
M/E transition control block	KEY1	Key >M/E Key1 >Main	Page 83
	KEY2	Key >M/E Key2 >Main	
	EFF	Effect/Wipe >M/E Effect >Main	Page 70 Page 73 Page 78
	PST COLOR MIX <sup>c)</sup>	Misc >Transition	Page 60
	FM1 Clip	Misc >Clip Transition >M/E Clip Transition	Page 149
	FM2 Clip		
	FM3 Clip		
PGM/PST transition control block <sup>b)</sup>	WIPE	Effect/Wipe >P/P Wipe >Main	–
	PST COLOR MIX <sup>c)</sup>	Misc >Transition	Page 60
	FM1 Clip	Misc > Clip Transition >P/P Clip Transition	Page 149
	FM2 Clip		
	FM3 Clip		
Flexi Pad control block	ME/RGN + EFF/ WIPE	Effect/Wipe >M/E Effect >Main	Page 70 Page 73 Page 78
	PP/ALL + EFF/ WIPE <sup>b)</sup>	Effect/Wipe >P/P Wipe >Main	–
	MCRO	Register >Macro >Edit	Page 176
	SNAPSHOT	Register >Snapshot >Edit	Page 156
	TRANS RATE	Misc >Transition	Page 77
	TIMELINE <sup>c)</sup>	Timeline >Timeline	Page 161
	M/E K1 TRANS	Key >M/E K1 Trans >Main	Page 124
	M/E K2 TRANS	Key >M/E K2 Trans >Main	Page 124
	DEV CTRL	Misc >DDR/VTR >Timecode Status	Page 196
	ME KEY 1 (In M/E K1 TRANS mode)	Key >ME Key 1 >Main	Page 124
	ME KEY 2 (In M/E K2 TRANS mode)	Key >ME Key 2 >Main	Page 124
	EFF (In M/E K1 TRANS mode)	Key >M/E K1 Trans >Main	Page 83
	EFF (In M/E K2 TRANS mode)	Key >M/E K2 Trans >Main	Page 83
	Effect/Wipe control block	M/E 1CH	Effect/Wipe >M/E Effect >Main
M/E 2CH		Effect/Wipe >M/E Effect >Main	
P/P <sup>b)</sup>		Effect/Wipe >P/P Wipe >Main	–

### Menus accessed by double clicking

Button location	Button	Menu	Reference page
Utility control block	DEV1 <sup>d)</sup>	Misc >DDR/VTR >TC Status	Page 196
	DEV2 <sup>d)</sup>	Misc >DDR/VTR >TC Status	
	DEV3 <sup>d)</sup>	Misc >DDR/VTR >TC Status	
	DEV4 <sup>d)</sup>	Misc >DDR/VTR >TC Status	
	DEV5 <sup>d)</sup>	Misc >DDR/VTR >TC Status	
	DEV6 <sup>d)</sup>	Misc >DDR/VTR >TC Status	
	FM 1 V CLIP <sup>d)</sup>	Frame Memory >Clip Play	Page 145
	FM 1 K CLIP <sup>d)</sup>		
	FM 2 V CLIP <sup>d)</sup>		
	FM 2 K CLIP <sup>d)</sup>		
	FM 3 V CLIP <sup>d)</sup>		
	FM 3 K CLIP <sup>d)</sup>		
	FM 1 CLIP <sup>d)</sup>		
	FM 2 CLIP <sup>d)</sup>		
	FM 3 CLIP <sup>d)</sup>		
	M/E K1 TRANS <sup>d)</sup>		
	M/E K2 TRANS <sup>d)</sup>	Key >M/E K2 TRANS >Main	
	ME/RGN - EFF/ WIPE	Effect/Wipe >M/E Effect >Main	Page 70 Page 73 Page 78
	PP/ALL + EFF/ WIPE	Effect/Wipe >P/P Wipe >Main	–
	MCRO	Register >Macro >Edit	Page 176
SNAPSHOT	Register >Snapshot >Edit	Page 156	
TRANS RATE	Misc >Transition	Page 77	
DEV CTRL	Misc >DDR/VTR >Timecode Status	Page 196	
TIMELINE	Timeline >Timeline	Page 161	

a) Button assigned with Video/Key Pair Assign menu (see page 207).

b) Not found on 1 M/E panel.

c) Button assigned with Button Assign menu (see page 225).

d) Button assigned with Utility menu (see page 218).

## Accessing Menus by Single Clicking

A menu appears when you single click a parameter adjustment button to turn the adjustment function on (and the knobs take on the parameters which can be assigned for the adjustment). The buttons which access menus by single clicking are the following buttons in the Effect/Wipe control block.

- [BVLD EDGE] button
- [LIGHT] button
- [TRAIL/SHDW] button
- [BORD] button
- [SOFT] button
- [CROP] button

# Interpreting Menu Screens

There are two types of menu screen.

- Basic screen (see next section)
- Popup windows
  - General popup windows (see page 36)
  - General popup windows (scrolling type) (see page 37)
  - Numeric keypad window/timecode window (see page 37)
  - Hexadecimal keypad window (see page 39)
  - Keyboard window (see page 40)
  - Page number input window (see page 42)

## Basic Screen

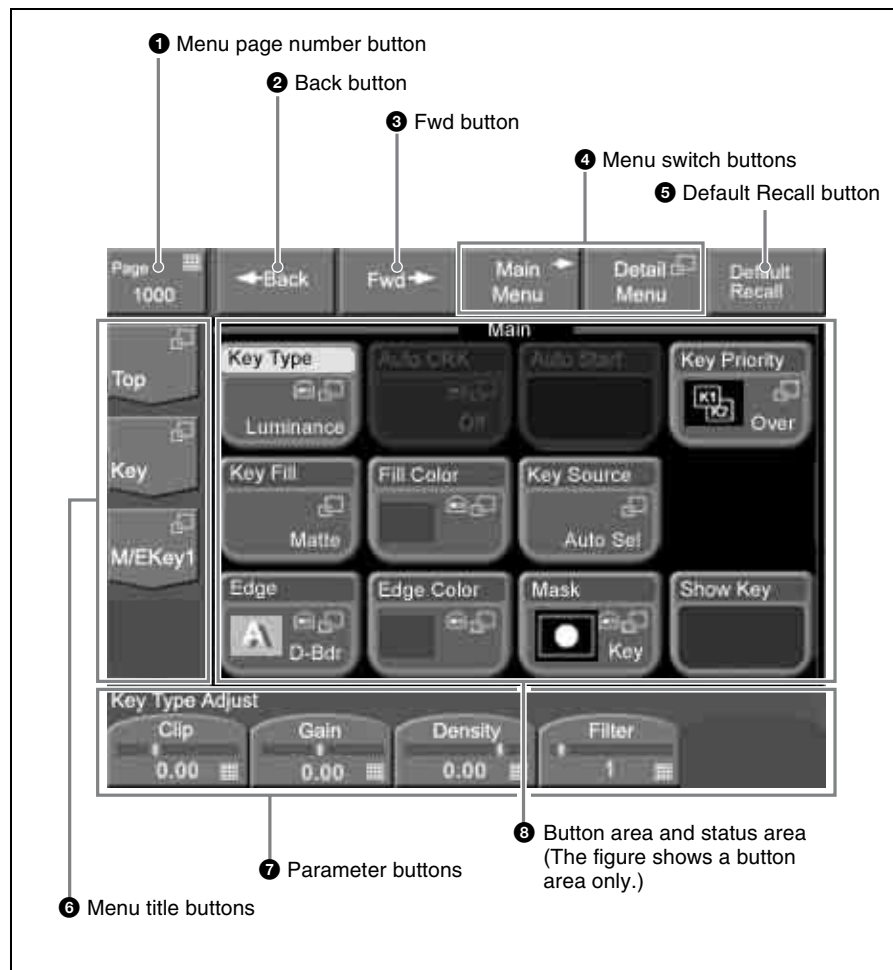

### 1 Menu page number button

This shows the menu screen page number.

When you press this button, the page number input window (see page 42) appears. Enter a page number in that window to display the desired menu.

For details about operation, see “Selecting menus by entering page numbers” (page 44).

For details about page numbers, refer to “Menu Tree” in the Appendix (separate document).

## ② Back button

Returns to the most recently displayed menu. You can go back up to maximum of 50 menus.

This button is disabled when the display history has been erased and when you have backed up through the entire display history.

For details about operation, see “Selecting menus from the display history” (page 44).

## ③ Fwd (forward) button

Redisplays the menu that was visible when you last pressed the Back button. This button is disabled when the display history has been erased, when you have moved forward through the entire display history, and when the display history has been updated by displaying a new menu.

For details about operation, see “Selecting menus from the display history” (page 44).

## ④ Menu switch buttons

You can use the following buttons to switch between the menus when you have selected a Key menu or an Effect/Wipe menu.

**Main Menu button:** Displays a menu with frequently used items.

**Detail Menu button:** Displays a popup window for selecting menus to make detailed settings.

When you have selected a Frame Memory menu, the following buttons function as menu switch buttons.

**Recall button:** Displays the Frame Memory >Recall menu.

**Detail Menu button:** Displays a popup window for selecting menus to make detailed settings.

## ⑤ Default Recall button

Displayed in menus only when default recall is enabled. A popup window for selecting a bank or functional unit appears when you press this button. You can use this window to return setting data to initial values <sup>1)</sup> in the following banks or functional units.

- M/E: M/E bank
- P/P: PGM/PST bank
- M/E Key1: Functional unit in the Key >M/E Key1 menu <sup>3)</sup>
- M/E Key2: Functional unit in the Key >M/E Key2 menu <sup>3)</sup>
- DSK1: Functional unit in the Key >DSK1 menu <sup>3)</sup>
- DSK2: Functional unit in the Key >DSK2 menu <sup>3)</sup>
- M/E K1 Trans: Functional unit in the Key >M/E K1 Trans menu <sup>4)</sup>
- M/E K2 Trans: Functional unit in the Key >M/E K2 Trans menu <sup>4)</sup>
- M/E Effect: Functional unit in the Effect/Wipe >M/E Effect menu <sup>3)</sup>
- P/P Wipe: Functional unit in the Effect/Wipe >P/P Wipe menu <sup>2), 3)</sup>
- CCR1: Functional unit in the CCR >CCR1 menu <sup>3)</sup>
- CCR2: Functional unit in the CCR >CCR2 menu <sup>3)</sup>
- Color Bkgd: Functional unit in the Misc >Color Bkgd menu <sup>3)</sup>

1) According to the Initial status setting (Factory or User) in the Startup Mode menu (see page 202). However, for M/E Effect data, the effect control parameters for patterns 1001 to 2999 are returned to the factory default values.

2) 1.5 M/E panel only

3) Includes functions in sub menus.

4) Except for transition types.

See “Returning Setting Data to Default Values” (page 46) for more information about the procedure.

### 6 Menu title buttons

Except for the Top button, these buttons display the title of the selected of the selected menu. The upper buttons correspond to upper level menus. In the example of the previous figure, [Top] is the top menu, [Key] is a first-level menu, and [M/E Key1] is a second-level menu.

When you press a button, a popup window appears to allow you to select a menu from the next level.

For details about operation, see “Selecting by navigating the menu tree” (page 43).

### 7 Parameter buttons

Parameters adjustable by knobs and their values are shown on the buttons.

When you press one of these buttons, the numeric keypad window (see page 37) opens so that you can enter a setting value.

### 8 Button area and status area

The button area displays the buttons of the operation target items in the selected menu.

In the setup menu and other menus, a status area may also be displayed to show lists for selecting setting values (see following figure).

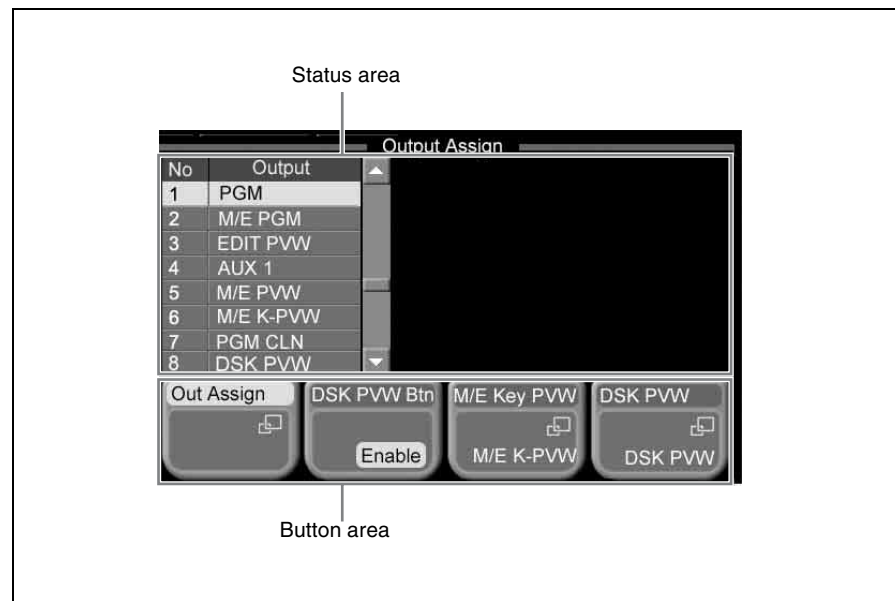

### Interpreting buttons

The following figure shows the information displayed on function buttons.

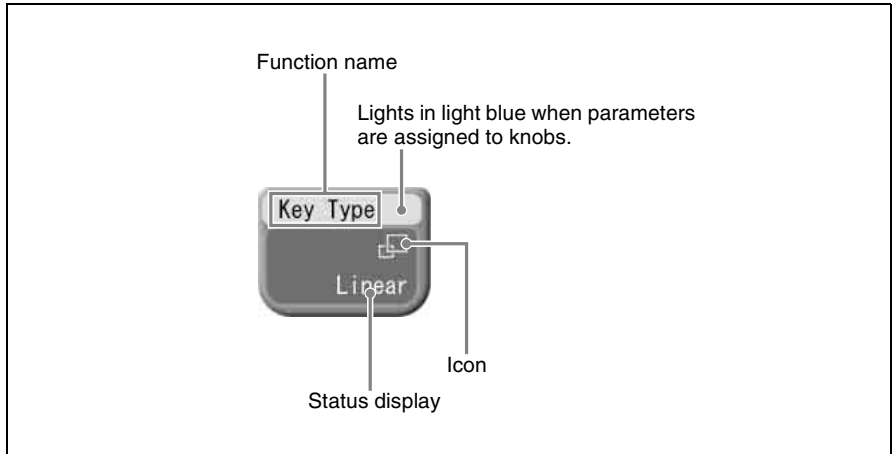

The following table shows how to interpret other buttons.

Name	Display	State
Parameter button		Value displayed. Value can be changed.
Execute button		Not executing function.
		Executing function (lit in light purple).

### Icons displayed on buttons

The following table shows the icons which are displayed on buttons, and the functions which they represent. The functions are executed when a button with the corresponding icon is pressed.

Name	Display	Function
Popup icon		Open a popup window.
Numeric keypad icon		Open the numeric keypad window, the timecode window, the hexadecimal keypad window, or the page number input window.
Keyboard icon		Open the keyboard window.
Shortcut icons		Switch the menu display.
Close icon		Close a popup window.
Scroll icons		<ul style="list-style-type: none"> <li>• Scroll the function button area.</li> <li>• Scroll the list in the status area.</li> <li>• Switch a pattern.</li> </ul>
Knob assigner icon		Assign a parameter to a knob.

Name	Display	Function
Window hold icon		Do not close a popup window even when a function selection button is pressed.

## Popup Windows

### General popup windows

When you press a button with the  icon, a popup window opens in the basic screen.

*The popup window may be the scrolling type. For details, see the next section.*

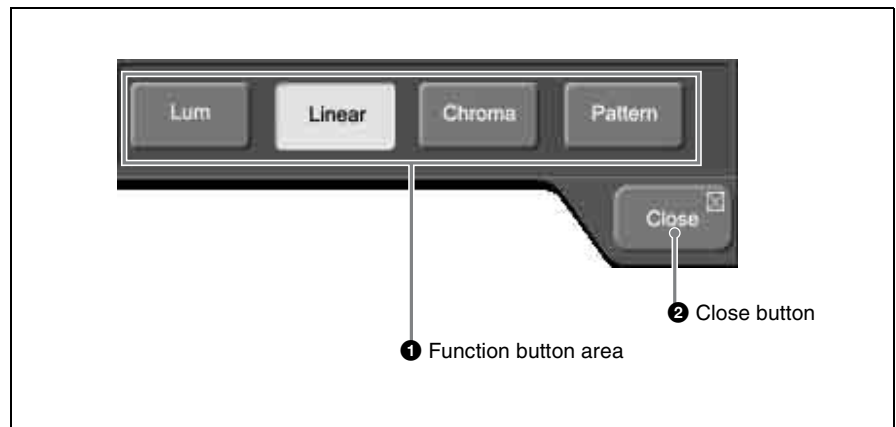

#### 1 Function button area

Displays functions and menus for selection. The currently selected button lights in light blue.

The popup window closes when you press a button in this area.

#### 2 Close button

Closes the popup window.

## General popup windows (scrolling type)

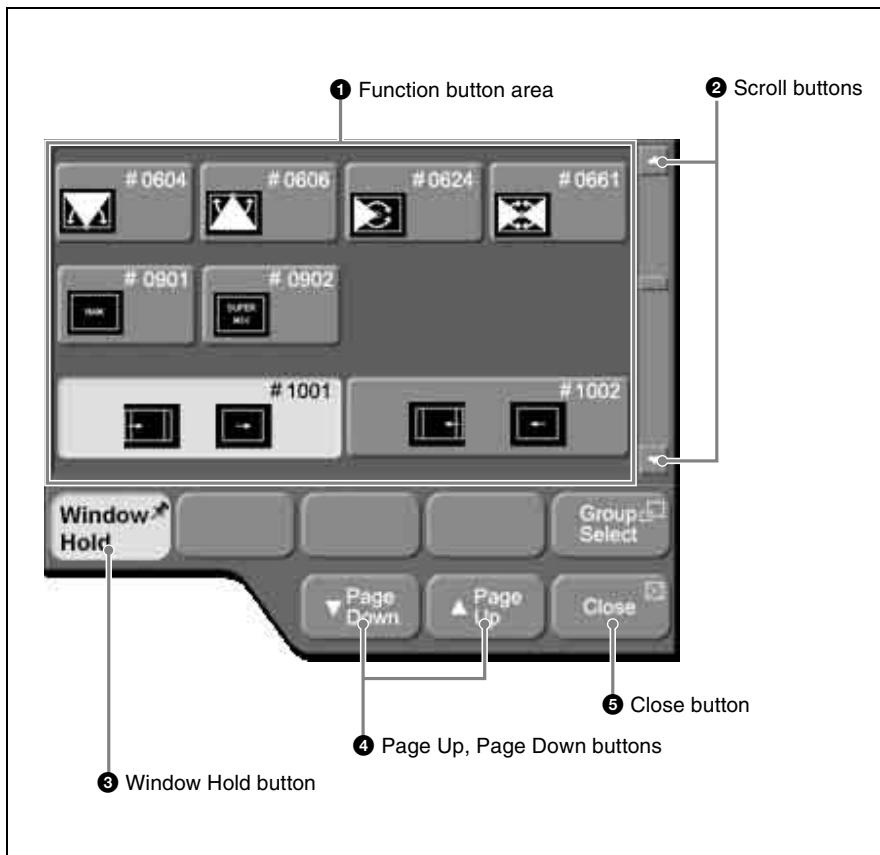

### ❶ Function button area

Displays functions and menus for selection.

The popup window closes when you press a button in this area. However, it does not close if the [Window Hold] button is on.

### ❷ Scroll buttons

Scroll the function button area up and down.

### ❸ Window Hold button

Press this button, turning it on, if you want to keep the window open even after pressing a button in the function button area.

### ❹ Page Up, Page Down buttons

Scroll the function button area up and down in page units.

### ❺ Close button

Closes the popup window (even when the [Window Hold] button is on).

## Numeric keypad window/timecode window

The numeric keypad window or timecode window opens when you press a button which is associated with parameter numeric input or timecode input. The



icon appears on the button.

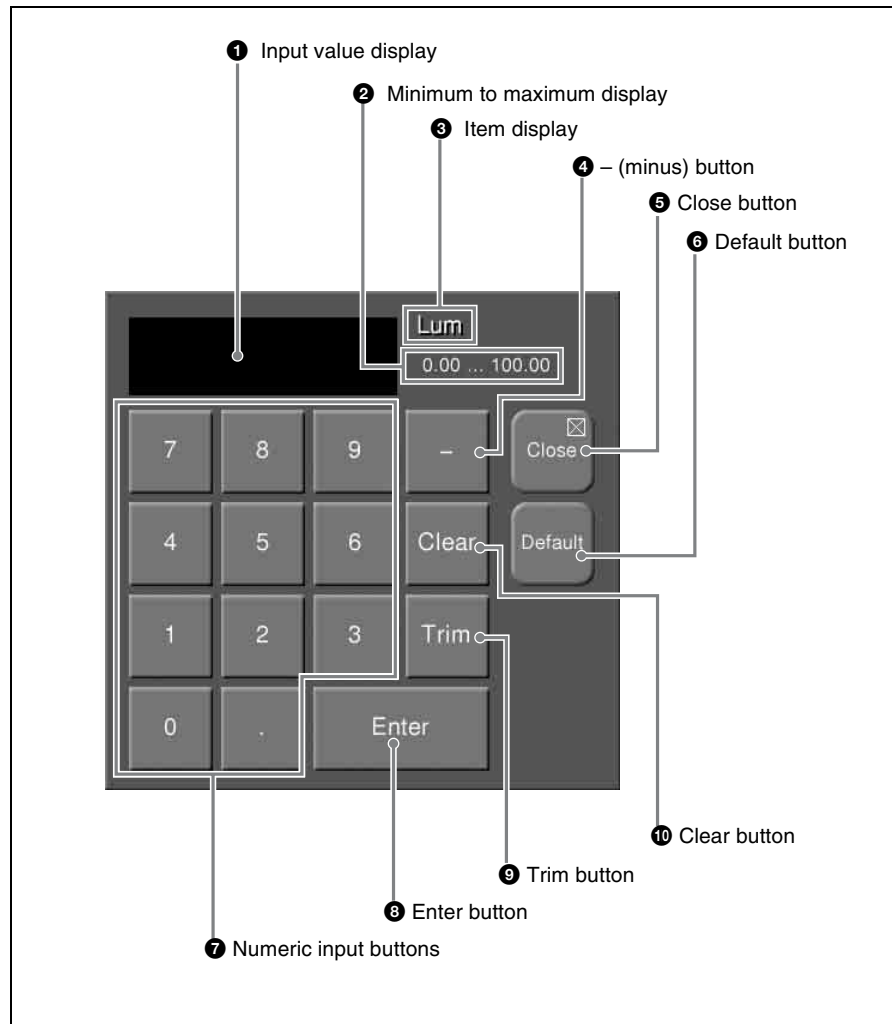

### ❶ Input value display

Shows the value entered in the numeric keypad window or the timecode window.

In the timecode window, values are shown in the format HH:MM:SS:FF (Hours:Minutes:Seconds:Frames).

### About timecode input

- A colon (:) is displayed automatically after every second digit when you enter three or more digits.
- Timecode is displayed in red if an entered value exceeds the setting range.

### Timecode input examples

The following table shows examples of timecode input

Digits entered	Display	Setting value
[1], [2]	12	00:00:00:12
[1], [2], [2], [0]	12:20	00:00:12:20
[1], [2], [2], [0], [5]	1:22:05	00:01:22:05

### ❷ Minimum to maximum display

Displays the minimum and maximum values that can be set for the parameter. Does not display anything in the timecode window.

**3 Item display**

Displays the name of the parameter being set in the numeric keypad window or timecode window.

**4 – (minus) button**

Changes the sign of the input value.

Each press toggles between plus (+) and minus (-).

Not supported in the timecode window.

**5 Close button**

Closes the numeric keypad window or the timecode window.

**6 Default button**

Appears in the numeric keypad window only for parameters that can be returned to default values. When pressed, this button returns the parameter to the default value.

**7 Numeric input buttons**

Use these buttons to enter the value you want to set.

In the timecode window, the [.] button changes into a [00] button.

**8 Enter button**

Confirms the entered value.

If the value is valid, the numeric keypad window or the timecode window closes.

If the value is not valid, the window stays open and the color of the input value display changes to red.

**9 Trim button**

Enter an adjustment from the current value, then press the Trim button to confirm the entered value.

For example, if you press 8 when the current setting value is 50, then without pressing Enter press Trim, this confirms a setting of 58.

**10 Clear button**

Clears the input. However, parameter settings are not changed.

## Hexadecimal keypad window

The hexadecimal keypad window opens when you press a button which is associated with hexadecimal parameter input. The  icon appears on the button.

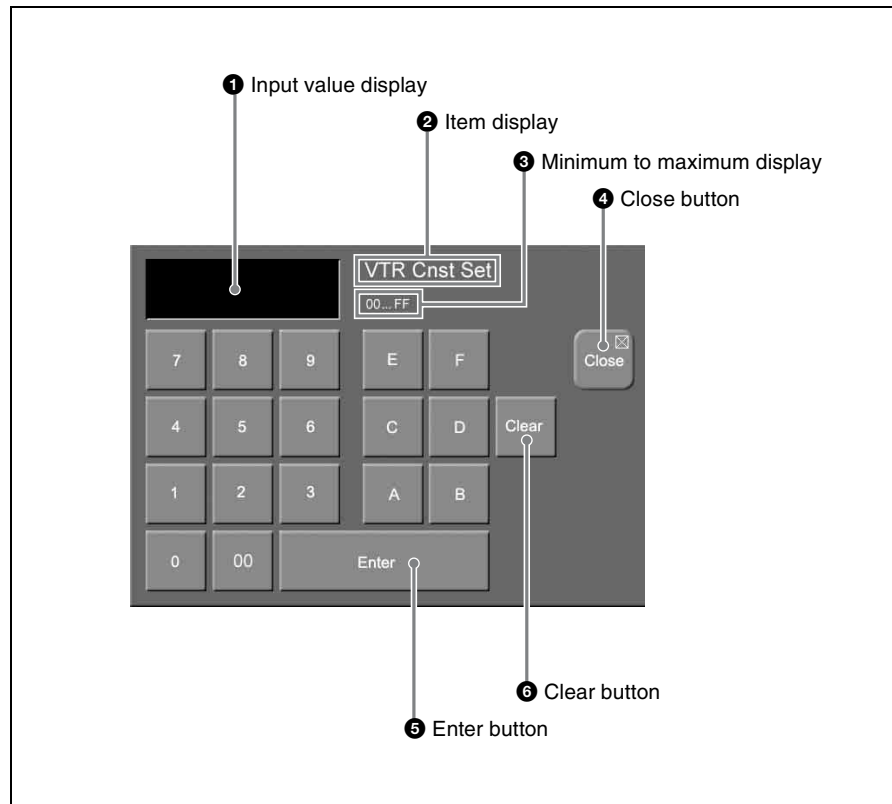

**1 Input value display**

Shows the value entered in the hexadecimal keypad window.

**2 Item display**

Displays the name of the parameter being set in the hexadecimal keypad window.

**3 Minimum to maximum display**

Displays the minimum and maximum values that can be set for the parameter.

**4 Close button**

Closes the hexadecimal keypad window.

**5 Enter button**

Confirms the entered value.

If the value is valid, the hexadecimal keypad window closes.

If the value is not valid, the hexadecimal keypad window stays open and the color of the input value display changes to red.

**6 Clear button**

Clears the input. However, parameter settings are not changed.

## Keyboard window

The keyboard window opens in the basic screen when you press a button with

the  icon.

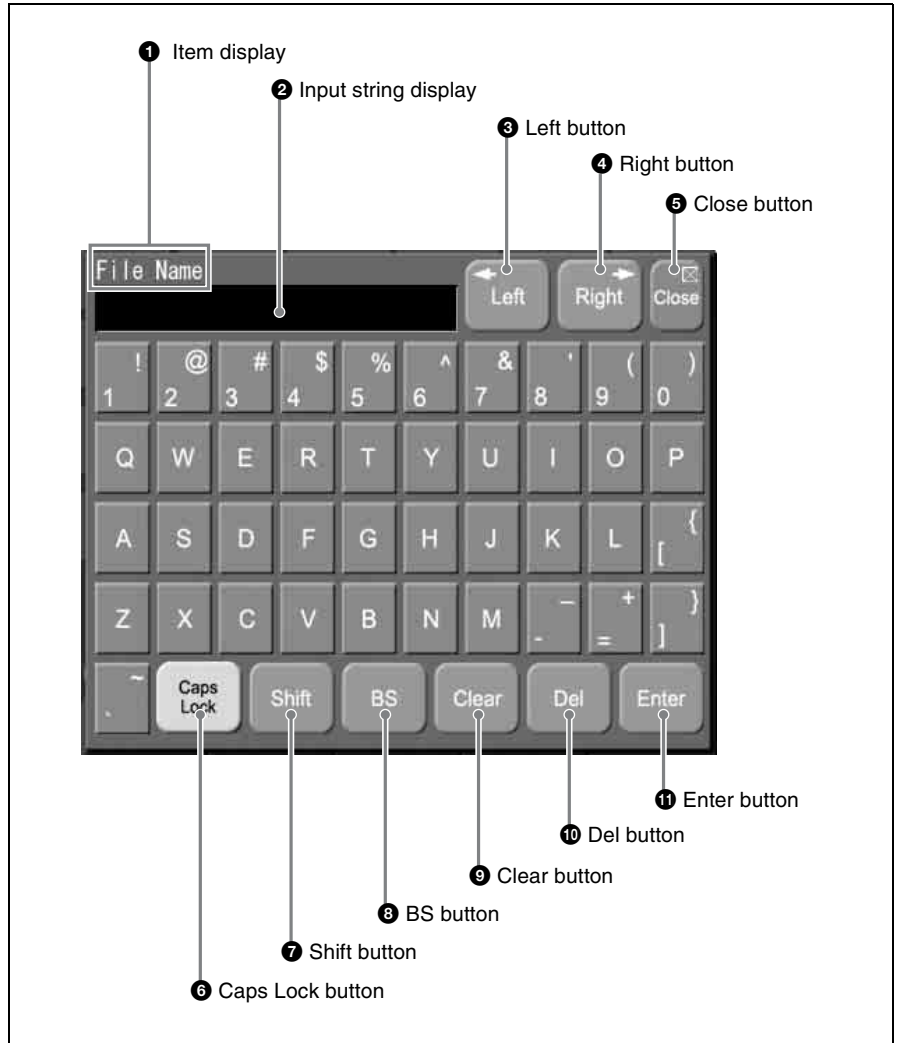

**1 Item display**

Shows the name of the parameter being set in the keyboard window.

**2 Input string display**

Shows the character string being input in the keyboard window.

**3 Left button**

Moves the cursor one character to the left in the input string.

**4 Right button**

Moves the cursor one character to the right in the input string.

**5 Close button**

Closes the keyboard window.

**6 Caps Lock button**

Switches between input of capital letters and lowercase letters.

**7 Shift button**

Enables input of characters on the shift side of the buttons. The shift is released when you enter a character.

**8 BS (backspace) button**

Clears the character immediately before the cursor in the input string.

**9 Clear button**

Clears all of the characters in the input string.

**10 Del (delete) button**

Clears the character immediately after the cursor in the input string.

**11 Enter button**

Sets the input string as a parameter value.

Closes the keyboard window if the value was valid. If the value was not valid, the window stays open and the color of the input value display changes to red.

## Page number input window

The page number input window opens in the basic screen when you press a menu page number button.

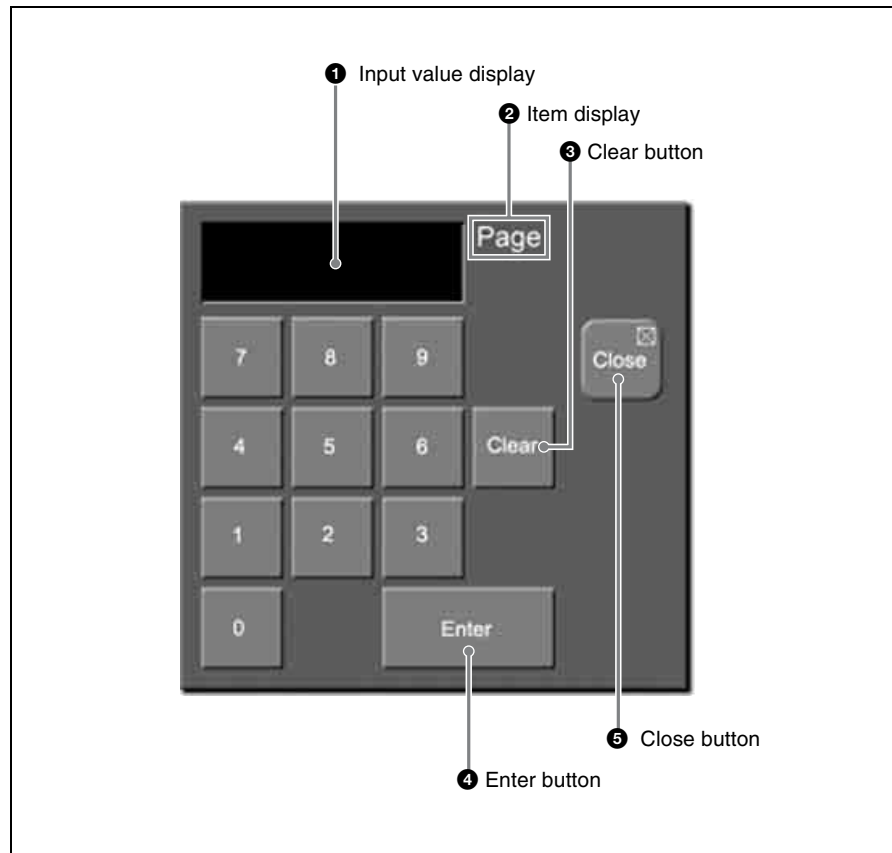
**1 Input value display**

Shows the value entered in the page number input window.

**2 Item display**

Shows that the value you are entering is a page number.

**3 Clear button**

Clears the input value.

**4 Enter button**

Confirms the input value.

**5 Close button**

Closes the page number input window.

# Basic Menu Operations

## Selecting Menus

There are three ways to select menus.

- Navigate the menu tree (see next section)
- Enter a page number (see page 44)
- Select from the display history (see page 44)

### Selecting by navigating the menu tree

You can display a desired menu by navigating to it through the menu tree from the currently displayed menu.

The following example shows how to select the Color Bkgd menu under the Misc menu when you are in the Main menu under a Key menu for the M/E bank.

In this manual, menu names and paths are indicated in the fashion “Key >M/E Key1 >Main”.

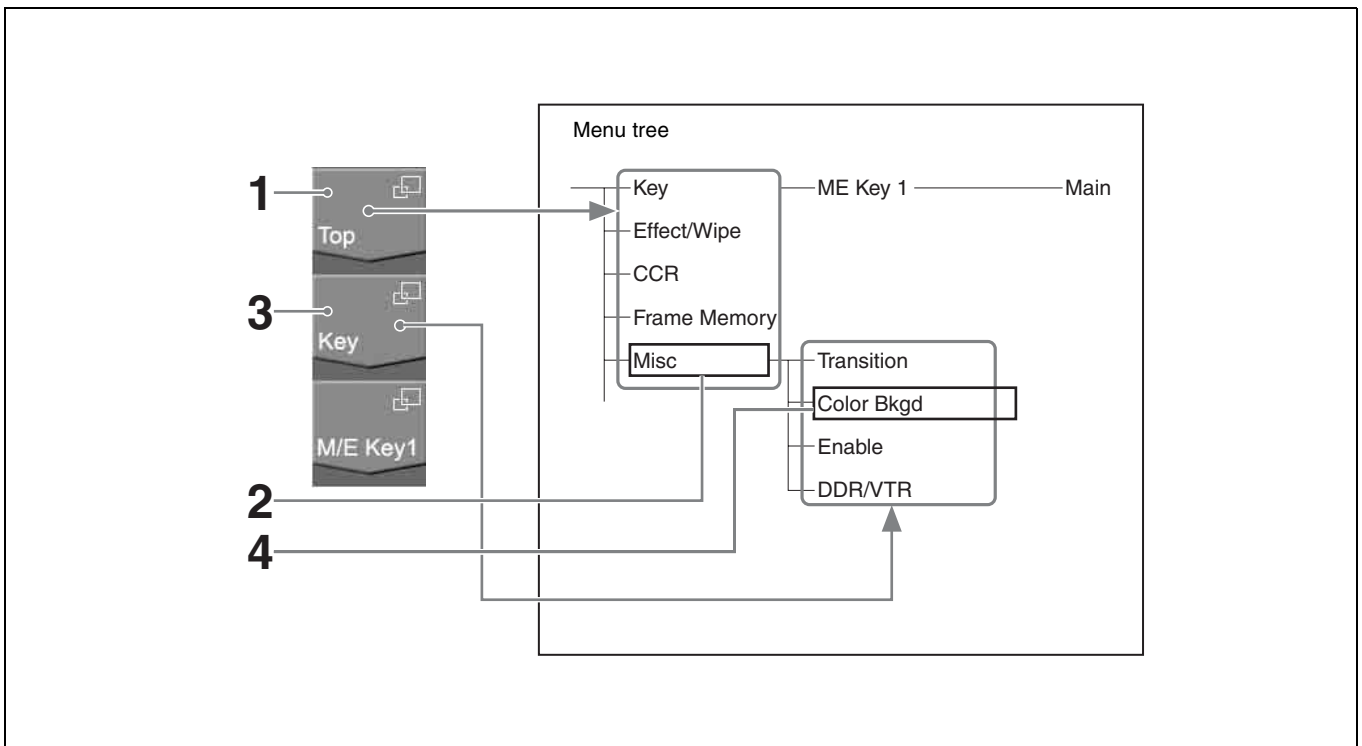

**1** Press [Top].

A popup window for selection of first-level menus appears.

**2** Select [Misc].

The popup window closes and the display changes to the Misc menu. The display on the second and third menu title buttons from the top changes to the display of the Misc menu.

**3** Press the second menu title button from the top.

A popup window for selection of second-level menus appears.

**4** Select [Color Bkgd].

The popup window closes and the display changes to the Color Bkgd menu.

**Selecting menus by entering page numbers**

You can display a desired menu by entering its page number.

*For more information about page numbers, refer to “Menu Tree” in the Appendix (separate document).*

**1** Press the menu page number button.

The page number input window (*see page 42*) appears.

**2** Enter the page number of the desired menu and press the [Enter] button.

The page number input window closes and the display changes to the desired menu.

**Selecting menus from the display history**

You can redisplay menus that have appeared in the past.

For example, if you have displayed menus in the order 1000 → 2000 → 3000 → 4000, you can go back to menu 2000 by pressing the [Back] button twice. After using the [Back] button, you can return in the reverse direction by using the [Fwd] button. In the above example, press the [Fwd] button twice to return to menu 4000.

**Selecting Functions**

To select a function, press the corresponding button in the button area of the basic screen.

The selected button lights in light blue.

Depending on the button, a popup window may appear so that you can select further items. Functions may also be assigned to knobs.

*See “Interpreting buttons” (page 34) for illustrations of how buttons change in appearance when they are selected.*

**Setting Parameters**

Parameter buttons light in light blue when they are pressed, and the parameters are assigned to knobs. Also, the parameter group name appears above the parameter button group. When you press a button to which a parameter has been assigned, the numeric keypad window opens so that you can input a numeric value. Or you may be able to set the parameter by rotating a knob. Parameters are assigned to knobs 1 to 5 in the order of parameter buttons from the left. When 6 or more parameters have been assigned, the 5th button functions as a page switch button (the [More] button). For example, when 8 parameters have been assigned, buttons 1 to 4 on menu page 1/2 are assigned to knobs 1 to 4 initially, and buttons 5 to 8 on menu page 2/2 are assigned to knobs 1 to 4 by page switching.

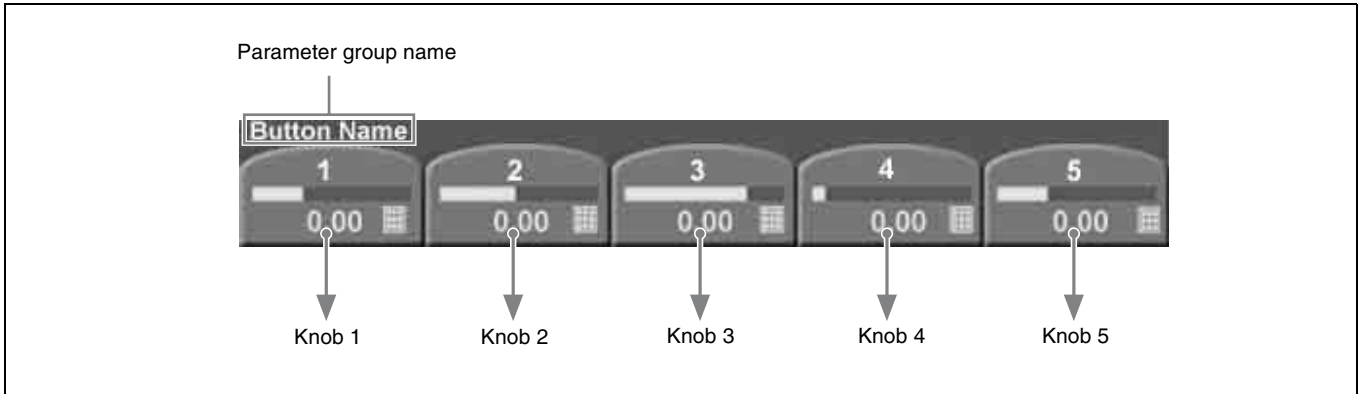

Parameter values can be set with either of the following methods.

- Rotate the knobs (1 to 5) corresponding to the parameters.
- Press the parameter button corresponding to a parameter, and enter a numeric value in the numeric keypad window.

Parameter values are indicated by the length of the bars on the buttons and by the numeric values under the bars.

In explaining specific operations, this manual gives examples of typical knob settings, expressed as shown below.

**Example 1:** When a pattern key is selected

Knob	Description	Setting values
1 (Size)	Size of pattern	0.00 to 100.00
2 (Soft)	Softness of edge width	0.00 to 100.00
3 (Density)	Key density	0.00 to 100.00
4 (Pattern)	Pattern number	1 to 24

**Example 2:** When a video process is selected

(The buttons of parameter group 1/2 are shown first, changing to parameter group 2/2 when the [More] button in the position of knob 5 is pressed.)

#### Parameter group 1/2

Knob	Description	Setting values
2 (Video Gain)	Overall gain of video signals	-200.00 to +200.00
3 (Y Gain)	Gain of luminance signals	-200.00 to +200.00
4 (Black Level)	Black level	-7.30 to +109.58

#### Parameter group 2/2

Knob	Description	Setting values
2 (Video Gain)	Overall gain of video signals	-200.00 to +200.00
3 (C Gain)	Gain of chrominance signals	-200.00 to +200.00
4 (Hue Delay)	Amount of hue offset	-180.00 to +180.00

---

## Returning Setting Data to Default Values

You can return setting data to initial values in banks or functional units.

- 1 Press [Default Recall] in a menu for which default recall is possible. (see page 33).

A popup window appears.



[P/P] and [P/P Wipe] appear only when you are using a 1.5 M/E panel.

- 2 Select a bank or functional unit.
- 3 Press [OK].

The selected bank or functional unit is returned to its default values.

### To cancel the operation

Press [Cancel].

---

# Exiting the Menu System

To exit the menu system, proceed as follows.

**Note**

Always exit the menu system before powering the control panel off.

**1** In the menu control block, press the [TOP/SHUTDOWN] button.

The top menu appears.

**2** Press [Shutdown].

A confirmation popup window appears.

**3** Press [Yes].

This shuts down the menu system after a while, and the menu display changes to black. Now power off the system.

**To cancel the exit**

Press [No].

**To restart the menu system**

Power on the control panel once more.



# ***Basics of Video Switching***

## Chapter

# 4

This chapter begins by explaining how to switch background signals on the M/E bank (how to perform transitions). Then it explains basic background video switching on the PGM/PST bank when a 1.5 M/E panel or 1.5 M/E wide panel is used.

The examples in this chapter assume that the following signals are currently selectable with the 2nd, 3rd, and 4th cross-point buttons from the left.

### **Signal selectable with the 2nd button from the left: Landscape video signal**



### **Signal selectable with the 3rd button from the left: Lion video signal**



### **Signal selectable with the 4th button from the left: Castle video signal**



# Basic Operations (1): Video Switching on the M/E Bank

Let's begin by using the M/E bank to select video signals showing a landscape and a lion as background video, and to switch between them with an effect. As the effect, we will use effect number 0024 (circular wipe). A wipe is an effect which the current video is wiped away by new video using a selected pattern. The video changes as follows.



### Preparations for operation

- If you are using the 1.5 M/E panel or 1.5 M/E wide panel, press and light the [M/E] buttons at the right edge of the PGM and PST button rows of the PGM/PST cross-point control block.
- Before starting, move the fader lever from one end of its range to the other, and stop it at the top position.

After finishing the above preparations, proceed as follows.

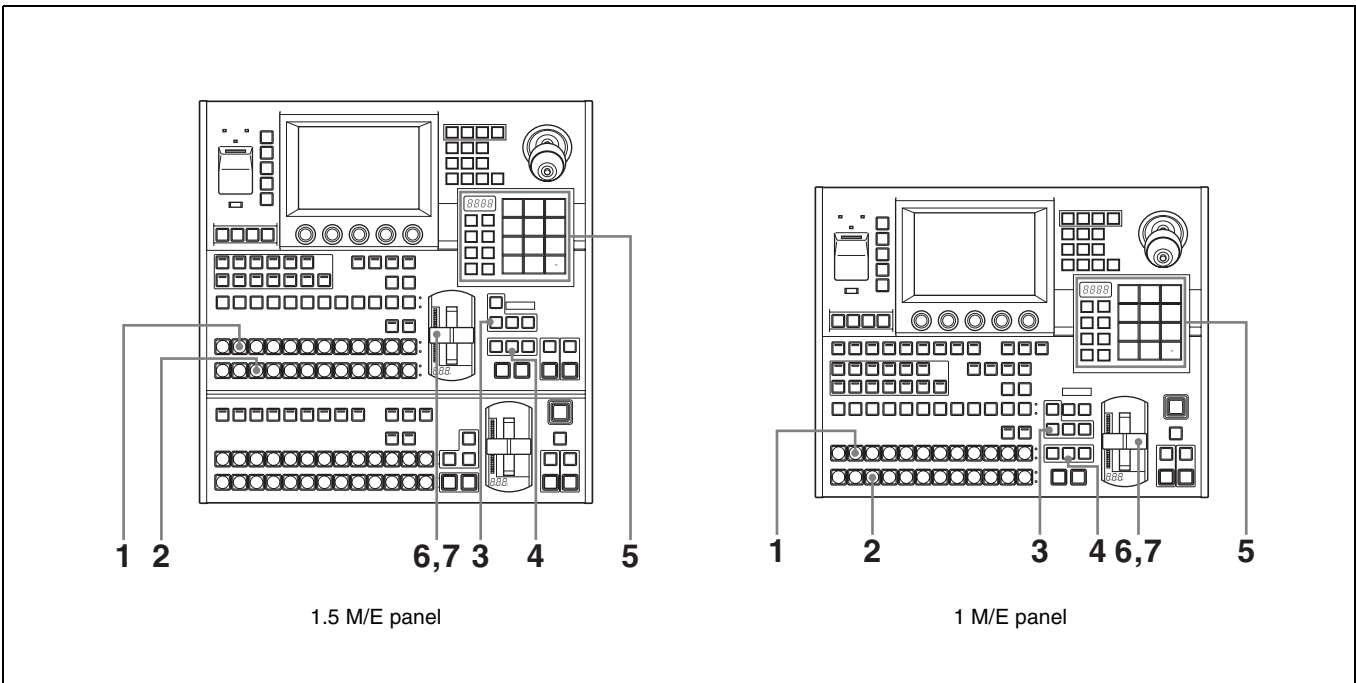

- 1** In the background A row of the M/E cross-point control block, select the A bus video.  
For this example, press the 2nd button from the left to select the landscape video signal.

The landscape video appears on the video monitor connected to the processor's program output (final output) connector. The pressed button lights in red to indicate that the signal assigned to the button is being output to the program video.

- 2** In the background B row, select the B bus video.  
For this example, press the 3rd button from the left to select the lion video signal.

The pressed button lights in amber to indicate that the signal assigned to the button has only been selected. It is not yet being output to the program video.

- 3** In the M/E transition control block, press the [BKGD] next transition selection button, lighting it. (Skip this step if the button is already lit.)

The background video is selected as the target of the transition.

- 4** In the M/E transition control block, press the [EFF] transition type selection button, lighting it. (Skip this step if the button is already lit.)

An effect is selected as the transition type.

- 5** Select the effect pattern (number 0024).

There are three ways to select effect patterns. In this example, we will use the Flexi Pad control block.

- 1)** Press the [ME/RGN] button in the Flexi Pad control block, lighting it.
- 2)** Press the [EFF/WIPE] button in the Flexi Pad control block, lighting it.
- 3)** Press the [PTN NO.] button, lighting it in green.
- 4)** With the numeric buttons, enter the digits 2,4, in that order.  
The number that you entered appears in the numeric display.
- 5)** Press the [ENTR] button.  
Pattern number 0024 is selected.

- 6** Slowly move the fader lever down from the top position.

A wipe transition using pattern number 0024 begins. A circle showing part of the video of the B bus (the lion) appears at the center of the A bus video (the landscape). The circle gradually grows larger, increasing the area occupied by the B bus video. While this is happening, the transition indicator LEDs to the left of the fader lever begin to light, starting from the top. The number of lit LEDs increases as the transition progresses.

At this point, notice how the buttons in the background A row and the background B row are lit. The button in the A row remains lit in red, but the color of the lit button in the B row has changed from amber to red. This indicates that both of the video signals selected by the buttons are being output to the program video.

- 7** Stop the fader lever at the bottom position.

The landscape video vanishes from the screen, leaving only the lion video. This completes the wipe transition.

Now, notice again how the buttons in the background A and B rows are lit. With the transition complete, the 3rd button from the left in the A row is lit in red, and the 2nd button from the left in the B row is lit in amber. This means that the signal selections in the A and B rows have been exchanged. In other words, the lion video is now selected in the A row, and the landscape video is selected in the B row.

In this state, try moving the fader lever from the bottom to the top. The transition takes place in the same direction as last time (from A bus video to B bus video), but this time the lion is replaced by the landscape.

### **About auto transitions**

An auto transition is executed if, in step **6**, you press the [AUTO TRANS] button in the transition execution control block instead of moving the fader lever.

The time from the start to the end of the transition is called the “transition rate” (unit: frames). The transition rate can be freely set in the range from 0 to 999 frames.

*See “Setting Transition Rates” (page 76) for more information about how to specify transition rates.*

### **About cut transitions**

A cut transition is executed if, in step **6**, you press the [CUT] button in the transition execution control block instead of moving the fader lever. In this case, the transition type selected in step **4** (effect) and the effect pattern selected in step **5** (0024) are ignored.



# Basic Operations (2): Video Switching on the PGM/PST Bank — For 1.5 M/E Systems

If you are using a 1.5 M/E panel or a 1.5 M/E wide panel, you can create the program video (final output video) on the PGM/PST bank. You can select background video and execute transitions with the same operations as the ones used on the M/E bank. You can also take video created on the M/E bank and use it as background video.

This section shows how to take the output of the M/E bank (for example, the lion video selected with the 3rd cross-point button from the left) and use it as background video. To replace it, we will use the castle video selected with the 4th cross-point button from the left. As the wipe pattern, we will use pattern number 0001, in which the new video gradually moves in from the left side of the screen.



## Preparations for operation

Before starting, move the fader lever in the PGM/PST transition control block from one end of its range to the other, and stop it at the top position.

After finishing the above preparations, proceed as follows.

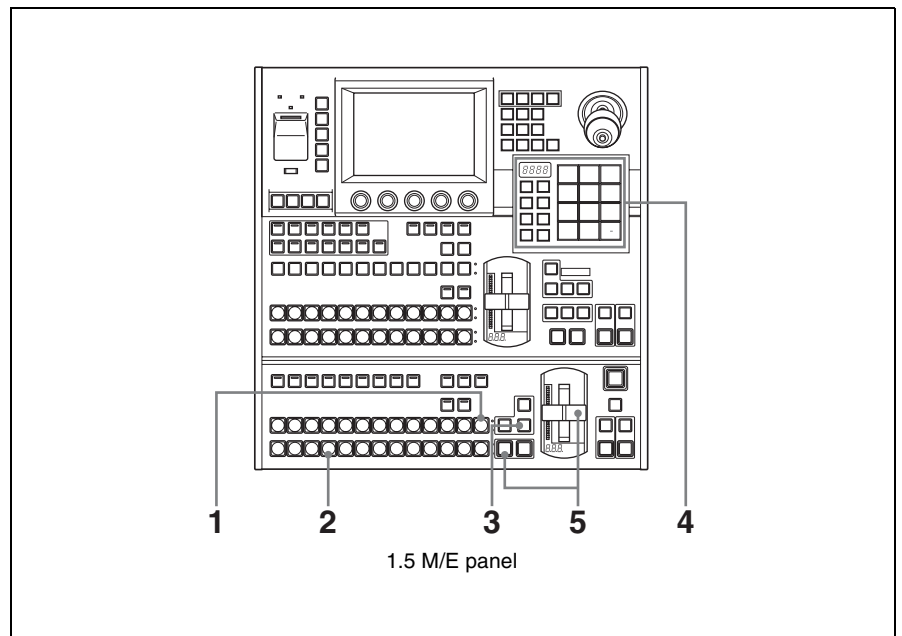



- 1** In the PGM row of the PGM/PST cross-point control block, press the [M/E] button at the right edge.

The [M/E] button lights in red, and the output video of the M/E bank (the lion) is selected as the PGM bus video. At this stage, the 3rd button from the left in the background A row on the M/E cross-point control block also lights in red.

- 2** In the PST row, press the 4th button from the left.

The button lights in amber, and the castle video is selected as PST bus video.

- 3** In the PGM/PST transition control block, press the [WIPE] transition type selection button, lighting it.

Wipe is selected as the transition type.

- 4** Select pattern number 0001.

When you use the Flexi Pad control block, proceed as follows.

- 1)** Press the [PP/ALL] button, lighting it.
- 2)** Press the [EFF/WIPE] button, lighting it.
- 3)** Press the [PTN NO.] button, lighting it in green.
- 4)** With the numeric buttons, enter the digit 1.  
The number that you entered appears in the numeric display.
- 5)** Press the [ENTR] button.  
Pattern number 0001 is selected.

- 5** In the PGM/PST transition control block, slowly move the fader lever down. Or, press the [AUTO TRANS] button.

The wipe transition starts. On the program monitor screen, the video of the castle gradually moves in from the left of the video of the lion. When the transition completes, the lion video is gone and the castle video occupies the entire screen.

At this stage, the colors of the lit cross-point buttons are as follows.

- 4th button from the left in the PGM row (selecting the castle video signal): Red
- [M/E] button at the right edge of the PST row (selecting the M/E output signal): Amber
- 3rd button from the left in the background A row on the M/E cross-point control block: Amber

## Selecting Video

### Flow of Operations

The following figure shows a typical flow of operations when using the MFS-2000 system. For details about operations, see the pages in parentheses ( ).

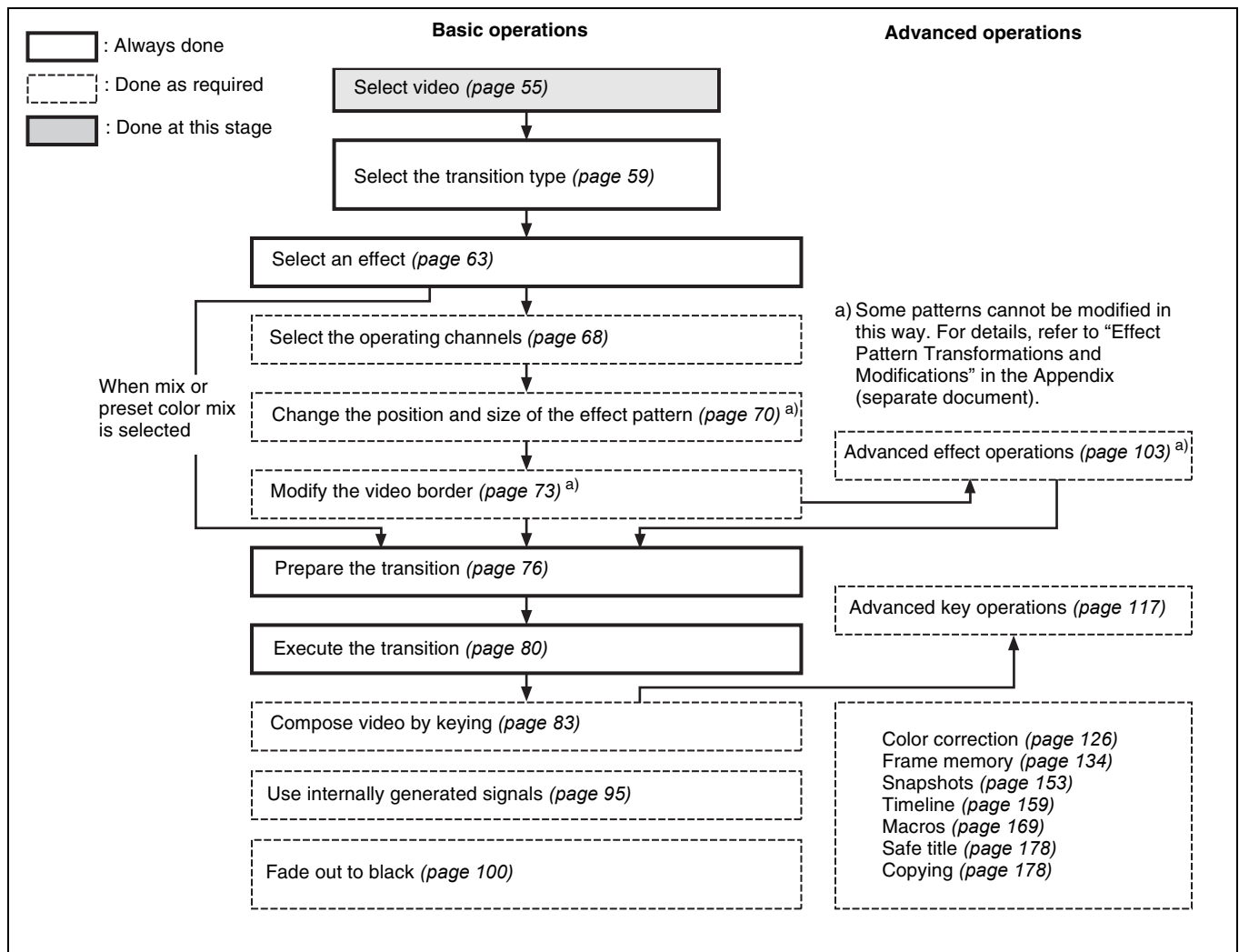

## Selecting Video in the M/E Cross-Point Control Block

To execute a background video transition, you need to prepare by selecting the background video before and after the transition on the M/E cross-point control block.

### When using the 1.5 M/E panel or 1.5 M/E wide panel

Program video (final output video) is created with the background video selected on the PGM/PST cross-point control block.

See the next section “Selecting Video in the PGM/PST Cross-Point Control Block” for more information about how to select video on the PGM/PST cross-point control block.

Select the background video displayed before the transition with the buttons in the background A row. Select the background video displayed after the transition with the buttons in the background B row.

The following table shows the correspondences between selectable signals and the cross-point buttons used to select them in the factory default configuration.

Selectable signal	Cross-point button used to select signal
Internally generated black signal	BLACK (left edge)
Internally generated color matte signal	COLOR BKGD (right edge)
Signals input to processor IN1 to IN8 connectors <sup>a)</sup>	Cross-point buttons other than the above

a) IN1 to IN16 when using the 1.5 M/E wide panel.

Assignments of signals to cross-point buttons can be freely changed using the Xpt Assign menu (see page 206).

To select video, proceed as follows.

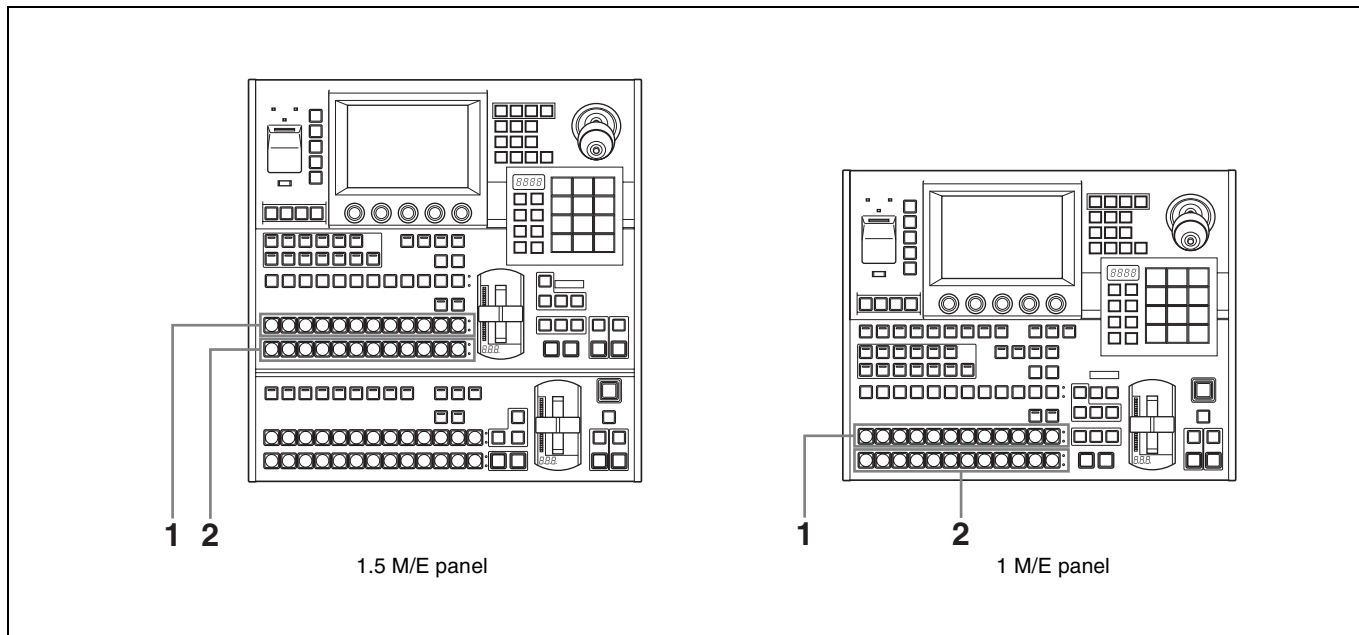

- 1 Press a button in the background A row to select the background video before the transition.

When the button pressed to select background video is lit in red, the video is displayed on the video monitor connected to the processor's program (final video) output connector.

- 2 Press a button in the background B row to select the background video after the transition.

The button lights in amber.

---

## Selecting Video in the PGM/PST Cross-Point Control Block

Select the background video before the transition by pressing a button in the PGM row. Select the background video after the transition by pressing a button in the PST row. Except for the [M/E] buttons at the right edge of the rows, the buttons have the same names and select the same signals as the buttons in the M/E cross-point control block.

### To import video created in the M/E bank as background video into the PGM/PST bank

Press the [M/E] button at the right edge of either row (PGM row or PST row).

---

## Selecting Video in the AUX Bus Control Block

In the AUX bus control block, you can use the AUX delegation buttons to assign the cross-point button row to the desired bus, allowing you to select key signals and signals to apply a variety of other functions.

The buses which can be selected by the AUX delegation buttons are as follows.

Button	Selectable bus
AUX1 to 4	AUX1 bus to AUX4 bus
EDIT PVW	Edit Pvw (edit preview) bus
UTIL	Utility bus
KEY1	[SRC BUS] button off: Key1 bus [SRC BUS] button on: Key1 Source bus
KEY2	[SRC BUS] button off: Key2 bus [SRC BUS] button on: Key2 Source bus
DSK1	[SRC BUS] button off: DSK1 (downstream key 1) bus [SRC BUS] button on: DSK1 Source (downstream key 1 source) bus
DSK2	[SRC BUS] button off: DSK2 (downstream key 2) bus [SRC BUS] button on: DSK2 Source (downstream key 2 source) bus
CCR1, CCR2	CCR1 (color correction1) bus, CCR2 bus
FRAME MEM	[SRC BUS] button off: Frame Memory Video bus [SRC BUS] button on: Frame Memory Key bus

For more information about the buttons in the AUX bus control block, see "AUX Bus Control Block" (page 15).

To select signals in the AUX bus control block, proceed as follows.

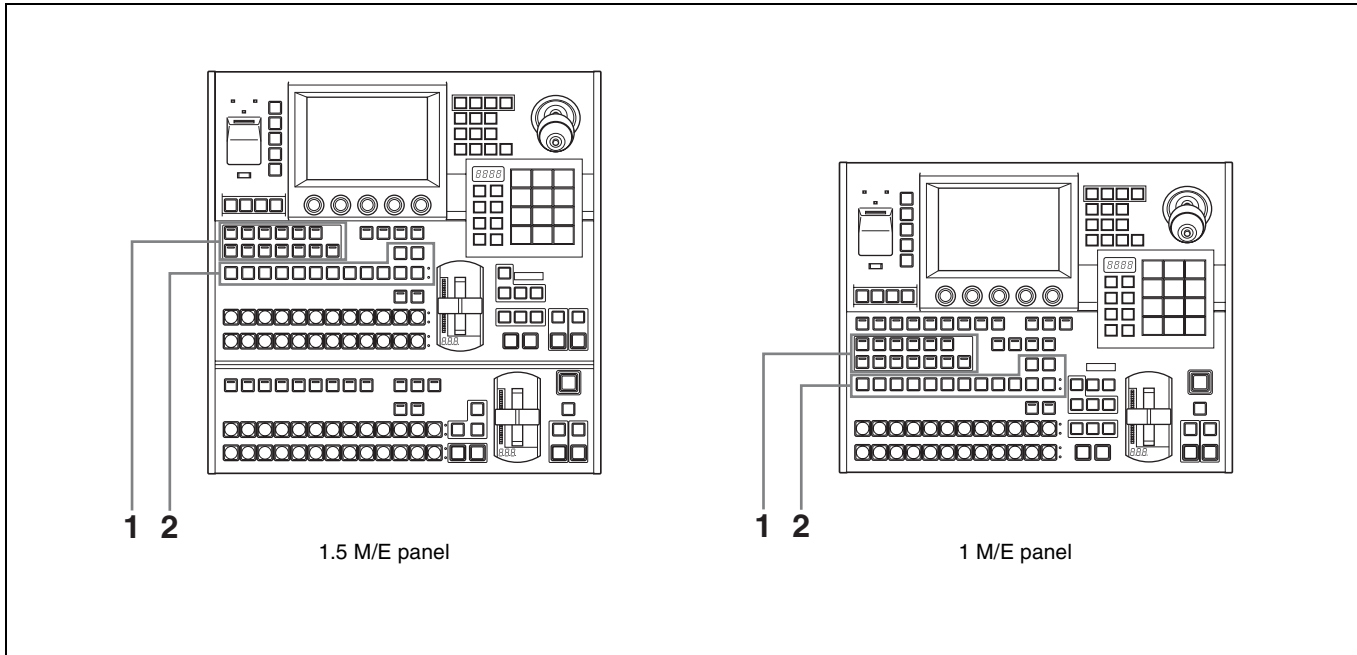

- 1** Press one of the AUX delegation buttons to select the bus to which the cross-point button row is assigned.
- 2** Press one of the buttons in cross-point button row to select the desired signal.

When a signal on the selected bus is being output to program video, the corresponding button lights in red (high tally). Otherwise the button lights in amber (low tally).

#### **To select the background of a 2-channel effect**

In some of the effect patterns from number 2001 to number 2999, utility bus signals are used as the background for the A bus and B bus video. For such effect patterns, first press the AUX delegation button [UTIL] and then press a button in the cross-point button row to select the signal to input to the utility bus.

# Selecting Transition Types

## Flow of Operations

The following figure shows a typical flow of operations when using the MFS-2000 system. For details about operations, see the pages in parentheses ( ).

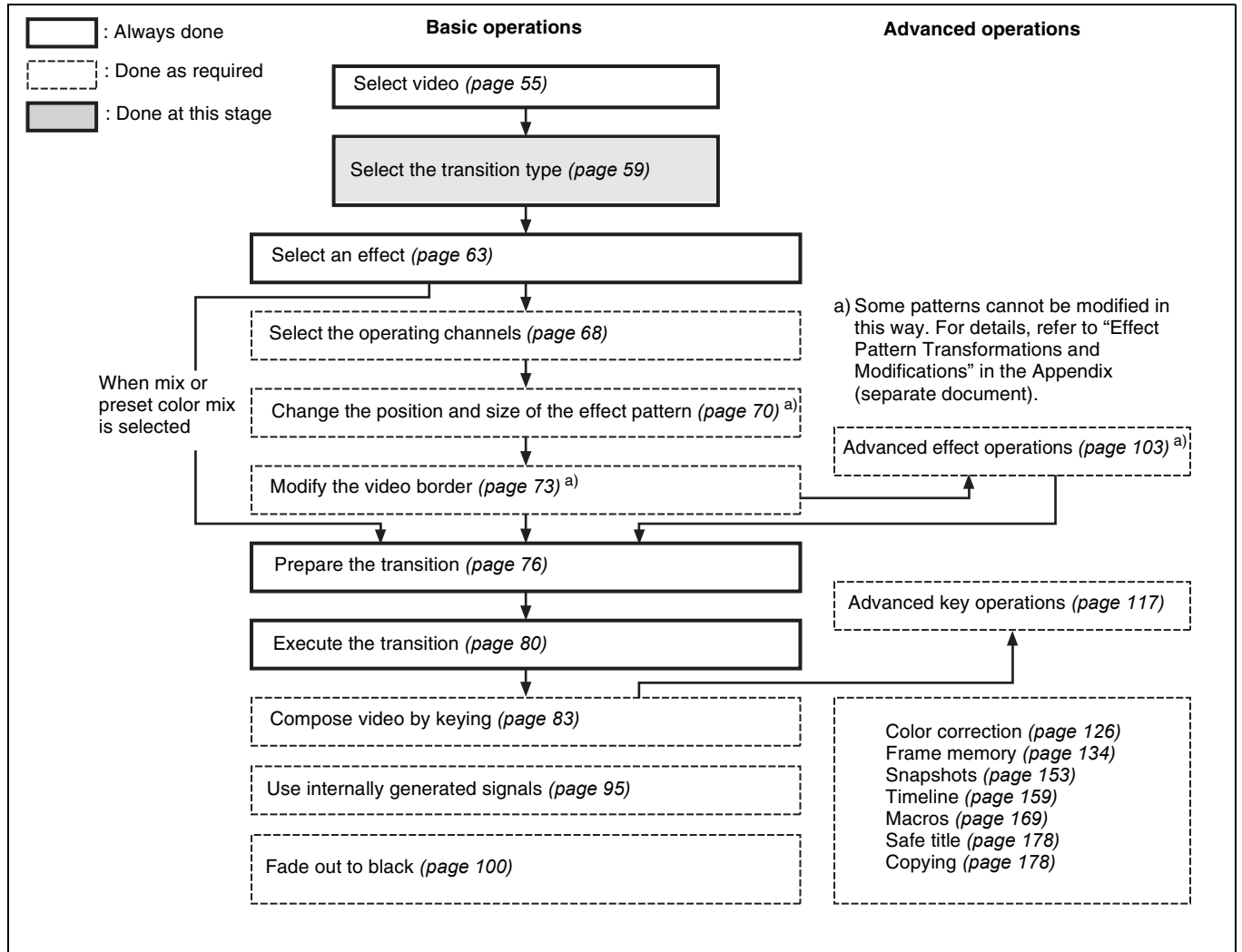

# Selecting the Transition Type and the Next Transition

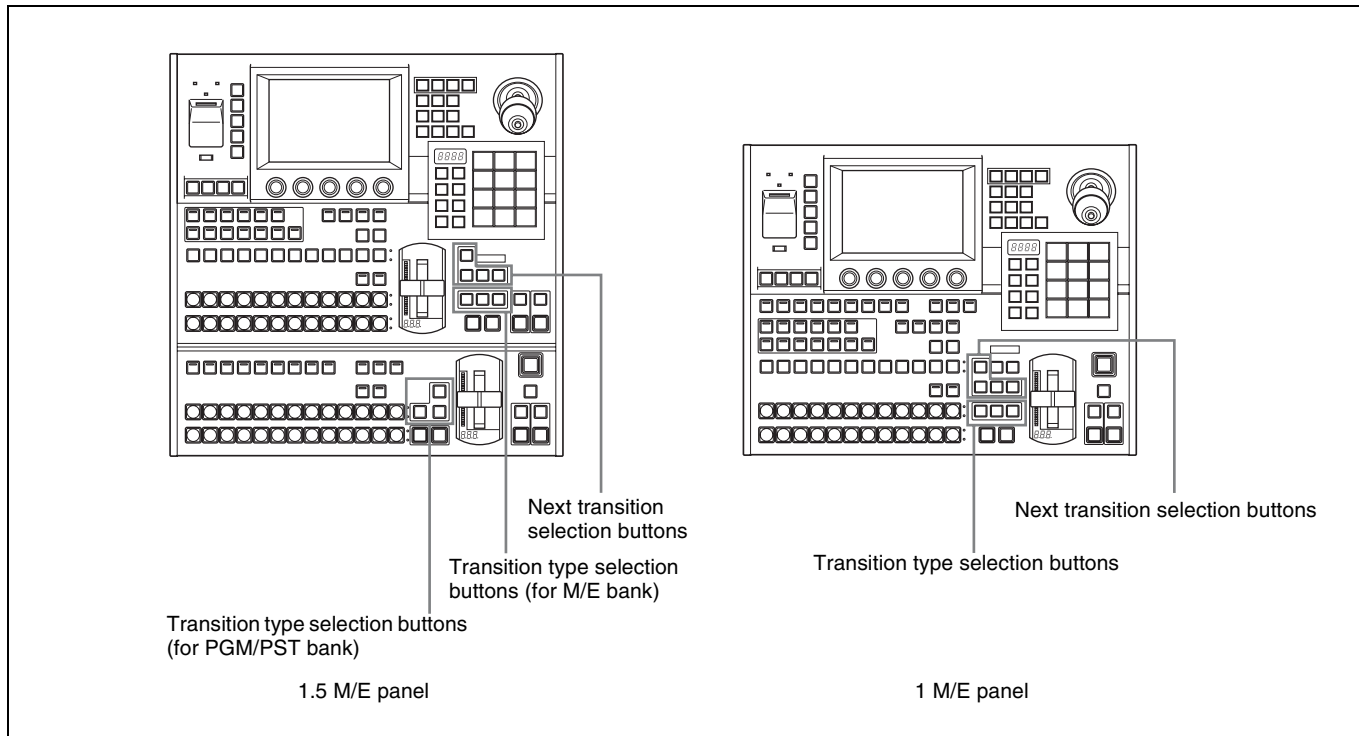

## To select the transition type

Press one of the transition type selection buttons in the M/E transition control block or the PGM/PST transition control block, lighting the button.

**MIX:** The new video overlaps the current video, finally replacing it.

**EFF:** A transition using an effect pattern is executed.

(In the PGM/PST bank, this button is [WIPE].)

**PST COLOR MIX:** This is a two-stage mix (dissolve), comprising two transitions. In the first transition, a color matte (non-patterned color signal) is gradually mixed into the current video. In the second transition, the new video is gradually mixed into the color matte.

When this is selected, you can use the following procedure to select the matte color.

The [EFF] button and the [PST COLOR MIX] button can be assigned with clip transition.

*For assigning the transition types, see “Changing the function of the transition type selection button in the transition control block” (page 226).*

## To select a color matte for preset color mix

**1** From the top menu, select Misc >Transition.

The Transition menu appears.



## 2 Select the target of the setting.

- Press [M/E Pst Col] to select a color matte for the M/E bank.
- Press [P/P Pst Col] to select a color matte for the PGM/PST bank (1.5M/E panel only).

A popup window appears, displaying the same 8 colors as a color bar.

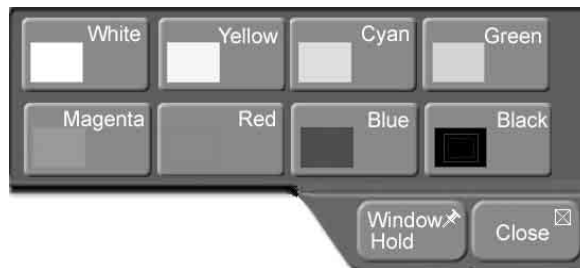

## 3 Press the button for the color that is closest to the desired color.

The popup window closes.

## 4 Set the following parameters with the knobs.

Knob	Description	Setting values
1 (Lum)	Luminance	0.00 to 100.00
2 (Sat)	Saturation	0.00 to 100.00
3 (Hue)	Hue	359.99 to 0.00

## To select transition types from menus

### 1 In the Misc > Transition menu, press [M/E Type].

A popup window appears.



## 2 Select one of the transition types.

*[Mix], [Effect] and [Pst Col Mix] in the above window are corresponding to the three transition type selection buttons. For details, see “To select the transition type” (page 60).*

*For FM1 Clip to FM3 Clip, see “Clip Transition” (page 149).*

### To select the next transition

Select the part of the video which changes in the transition.

Press one of the next transition selection buttons in the M/E transition control block, lighting the button.

(This operation is not needed for a transition in the PGM/PST bank, since only the background changes.)

**BKGD:** The background changes.

**KEY1:** Insert or delete key 1.

**KEY2:** Insert or delete key 2.

**KEY PRIOR:** Reverse the priority of key 1 and key 2.

*See “Composing Video With Keys” (page 83) for more information about working with keys.*

#### **Note**

When using effect patterns numbered 1001 or higher (*see page 67*), it is not possible to make multiple next transition selections. Also the [KEY PRIOR] button cannot be selected.

# Selecting Effects

When you have selected [EFF] as the transition type (*see page 60*) or selected [WIPE] (in the PGM/PST bank of the 1.5M/E panel), select the effect to use. Effects selectable in the PGM/PST bank are limited to basic wipes. The M/E bank can select basic wipes and other effects as well. This section refers to all of these together as simply “effects”.

*For more information about effects, see “Effect Types” (page 67).*

## Flow of Operations

The following figure shows a typical flow of operations when using the MFS-2000 system. For details about operations, see the pages in parentheses ( ).

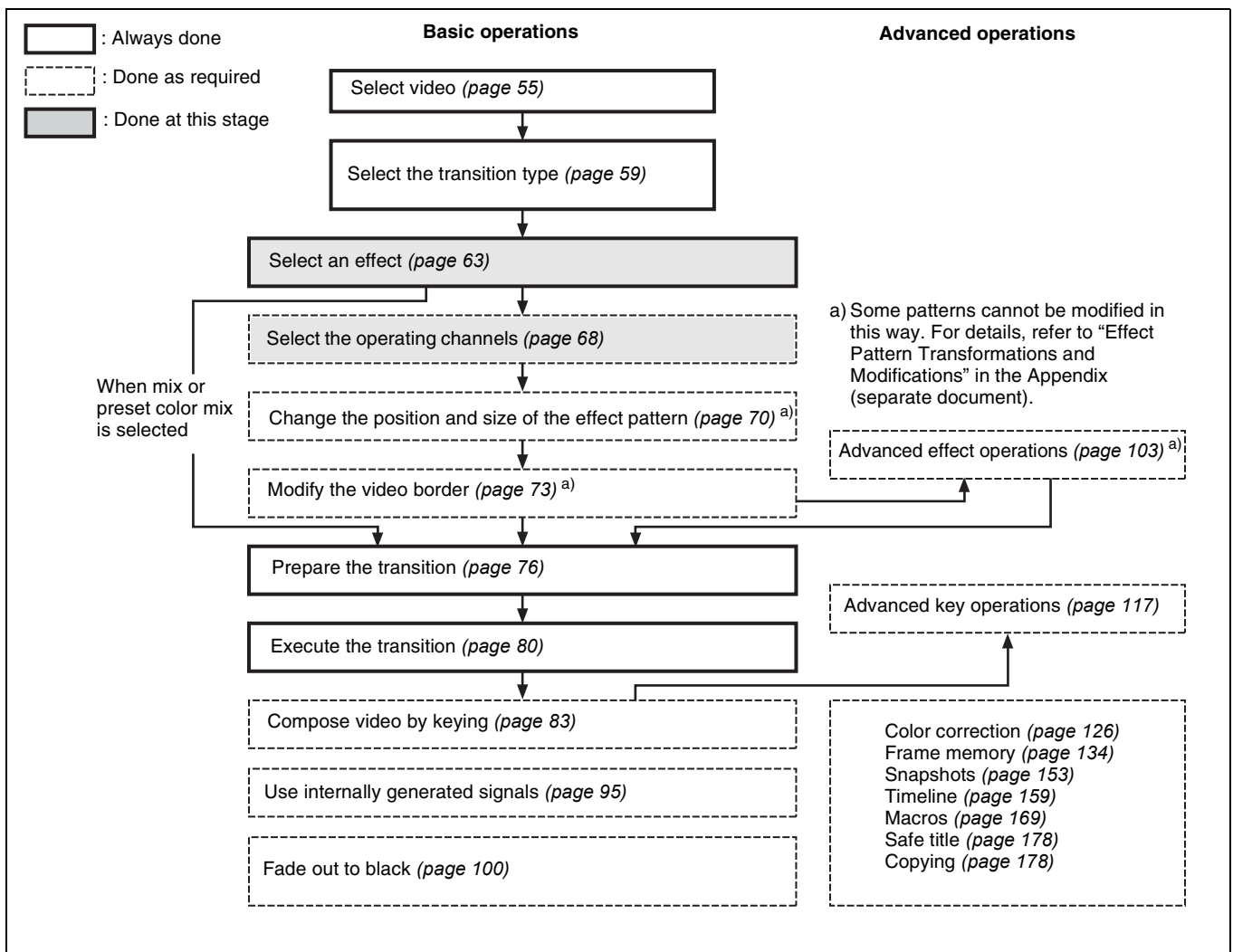

You can select effects using either the Flexi Pad control block or menus.

# Selecting Effects With the Flexi Pad Control Block

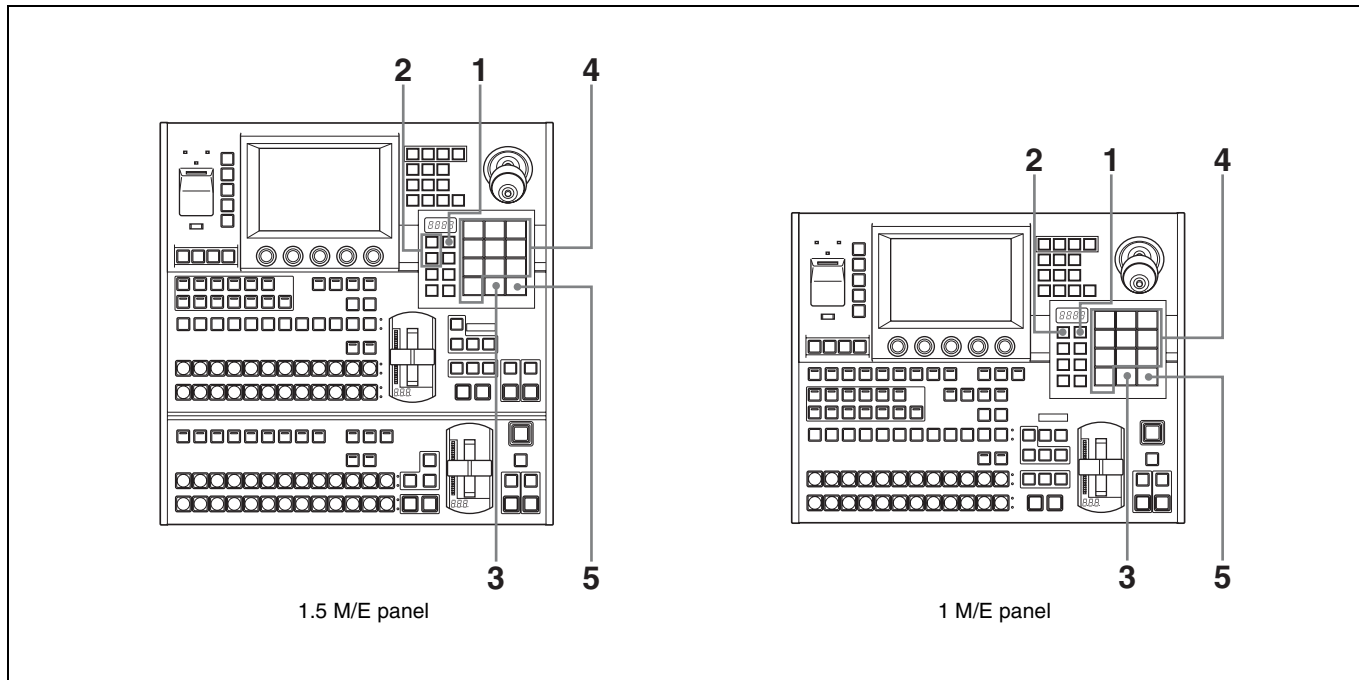

**1** Press the [EFF/WIPE] button in the Flexi Pad control block.

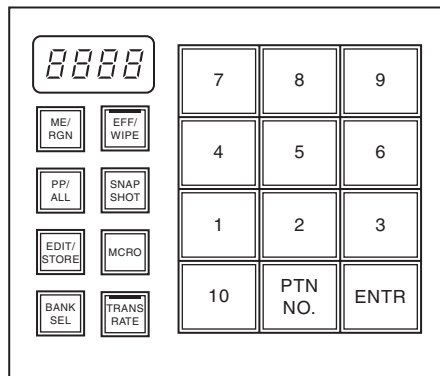

**2** Select the setting target with the delegation buttons.

- To set the M/E bank, press the [ME/RGN] button.
- To set the PGM/PST bank, press the [PP/ALL] button (when using a 1.5 M/E panel).

**3** Press the [PTN NO.] button, lighting it in green.

An effect number can be entered now.

The [PTN NO.] button lights alternately in green and orange each time it is pressed.

**4** Enter the number of the desired effect pattern.

If the number begins by 0, 00, or 000, it is needless to input these zeros. For example, when the number is 0001, input the digit 1 only.

Wipe patterns selectable in the PGM/PST bank are limited to 0001 to 0024, 0901, and 0902.

Refer to “Effect Pattern List” in the Appendix (separate document) for more information about effect patterns.

The entered effect pattern number appears in the numeric display.

**Note**

Effects numbered 1001 and higher cannot be used when:

- Multiple next transition selections have been made.
- Key priority (KEY PRIOR) has been selected as the transition type.

**To re-enter the pattern number**

Press the [PTN NO.] button so that it changes back to lit in orange, then repeat the procedure from step 3.

- 5 Press the [ENTR] button.

This confirms the effect pattern number entered in step 4.

**When an invalid pattern number is entered**

A warning tone sounds and the system exits pattern number input mode. Check the correct pattern number and repeat from step 3.

---

## Selecting Effects From Menus

- 1 From the top menu, select Effect/Wipe >M/E Effect >Main.

The Main menu appears.

(The example in the above figure shows effect pattern 0002 selected. See page 68 for an example of the screen when a pattern numbered 1001 or higher is selected.)

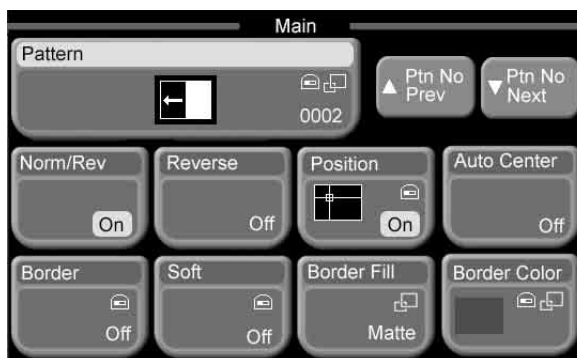

- 2 Press [Pattern].

A popup window appears.

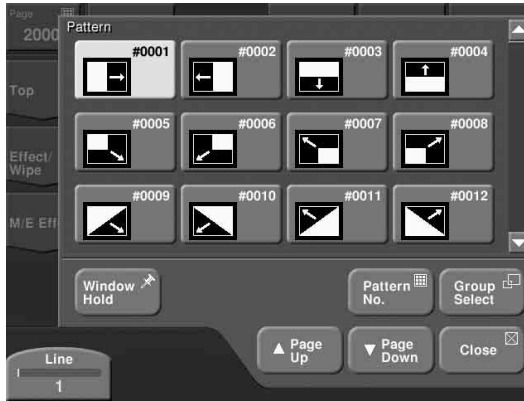

### To scroll the popup window

Do one of the following.

- Use the scroll bar on the right.
- Rotate knob 1. Each rotation scrolls 1 line up or down.
- Press [Page Down] or [Page Up]. Each press scrolls 3 lines up or down.

### 3 To select the desired pattern from a group of patterns, press [Group Select].

A popup window appears.



### 4 Select the name of the desired group.

The effect patterns in the selected group appear.

(The example in the following figure shows the Enhanced group.)

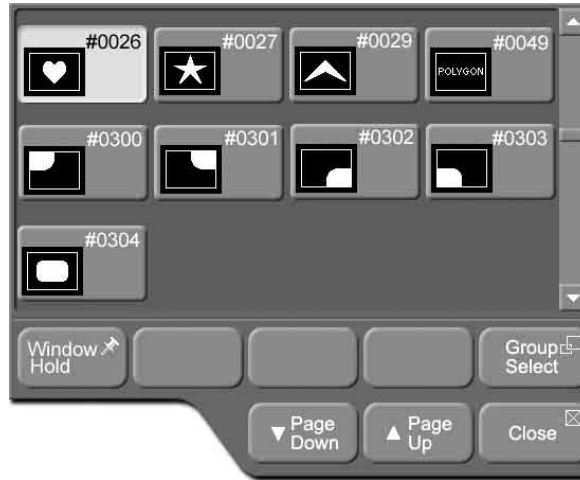

## 5 Press the button for the desired pattern.

The effect pattern is confirmed, the popup window closes, and you are returned to the Main menu.

### To select effects with pattern numbers

First press [Pattern No.] in step **3** of the above procedure and then enter the number of the desired effect pattern in the numeric keypad window.

## Effect Types

### About effect pattern numbers

The effects available on this system can be selected with 4-digit effect pattern numbers. These numbers can generally be classified as shown below. In general this manual calls all effects simply as “effects”, but when it refers to effects used on the PGM/PST bank, it calls them as “wipes”.

**Yes: Available for use    No: Not available for use**

Type	Effect pattern numbers	M/E	PGM/PST
Wipes	0001 to 0661	Yes	Standard group patterns only (0001 to 0024)
NAM	0901	Yes	Yes
Super mix	0902	Yes	Yes
Effects using DME	1-channel effects	1001 to 1999	Yes <sup>a)</sup> No
	2-channel effects	2001 to 2999	Yes <sup>a)</sup> No

a) DME option must be installed.

### Note

Effects numbered 1001 and higher cannot be used when:

- Multiple next transition selections have been made.
- Key priority ([KEY PRIOR]) has been selected as the transition type.

### Transition effects and non-transition effects

Effects numbered 1001 and higher fall into the following two types, depending on what occurs when the effect is executed.

**Transition effects** (slides, page turn, etc.): A bus and B bus cross-points are switched by executing a transition. Also, when border, cropping, or other modifications <sup>1)</sup> have been added, they disappear as soon as the transition ends.

1) Modifications listed in “Effect Pattern Transformations and Modifications” in the Appendix (separate document).

**Note**

When you add a shadow or trail to an effect applied to a key and then execute the transition, the shadow or trail disappears instantly as soon as the transition ends.

**Non-transition effects** (picture-in-picture, etc.): A bus and B bus cross-points are not switched, even after the effect ends. Also, when border, cropping, or other modifications <sup>1)</sup> have been added, they do not disappear, even after the transition ends.

1) Modifications listed in “Effect Pattern Transformations and Modifications” in the Appendix (separate document).

## Selecting Channels

When an effect pattern numbered 2001 or higher is selected, you need to select the operating channels.

### To select channels with the Effect/Wipe control block

Press the [M/E 1CH] or [M/E 2CH] delegation selection button in the Effect/Wipe control block, lighting the button. You can also select both channels.

### To select channels from menus

**Note**

Two channels cannot be selected at once from a menu.

However, when two channels are selected with the buttons in the Effect/Wipe control block, both of the buttons are lit in the menu.

- 1 From the top menu, select Effect/Wipe >M/E Effect >Main.

The Main menu appears.

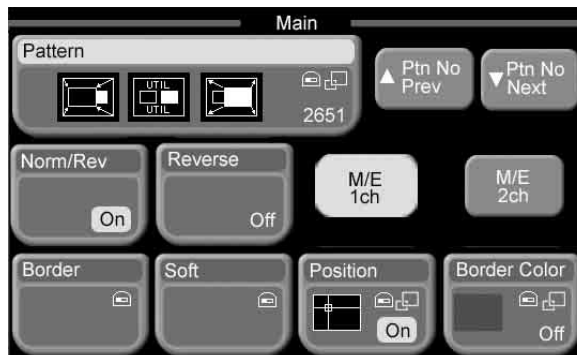

- 2 Press [M/E 1ch] or [M/E 2ch] to select a channel.

If two channels are selected with the delegation selection buttons in the Effect/Wipe control block of the control panel, the parameter setting values for the reference channel are shown in the menu. Settings for the two channels are adjusted with relative values.

## Setting the parameters of 2-channel effects

### Parameters which can be set individually for each channel

- Size and position of the effect pattern (Position), and border color of the effect pattern (Border Color)
- Brightness of beveled edges (Light mode), direction of light source (Light mode/Color mode), color (Color mode), softness of edges (Edge Soft)
- Adjustment of crop picture frame (Crop)

### Note

Among the parameters listed above, the following parameters are exceptions. For the indicated effects, they are set for both channels.

- Position of the Ripple (2ch) effect
- Crop of the Page Roll (2ch) effect
- Crop of the Page Turn (2ch) effect

### Parameters common to both channels

Parameters other than the above are set for both channel 1 and channel 2, even if only one of the channels has been selected with the [M/E 1CH] and [M/E 2CH] delegation selection buttons.

## Checking the DME status

Hold down the [EFF] button in the transition control block or the Flexi Pad control block.

The following window appears while the button is held down.

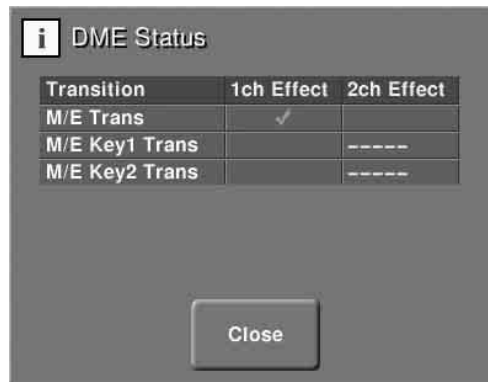

The window displays the operating status of DME as follows.

✓: Currently being used

-----: Not available

# Changing the Position and Size of Effect Patterns

You can change the position of effect patterns (*see following figure*) and change their size.

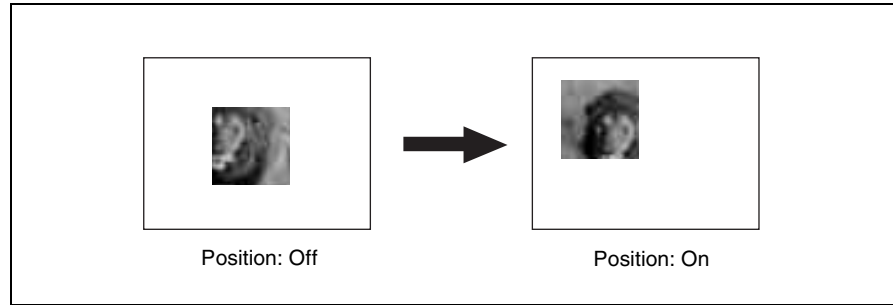

## Flow of Operations

The following figure shows a typical flow of operations when using the MFS-2000 system. For details about operations, see the pages in parentheses ( ).

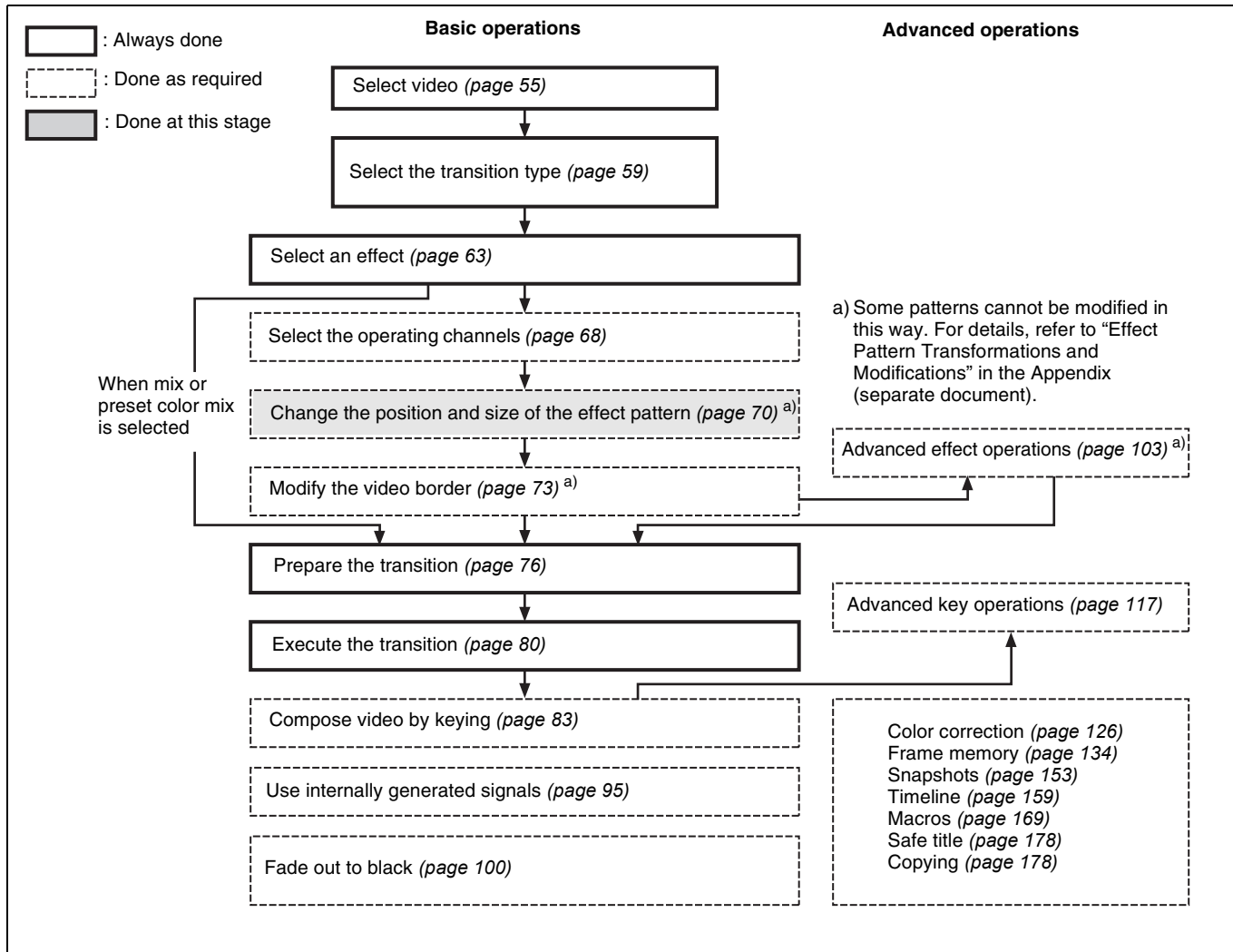

# Changing Pattern Position and Size With the Joystick

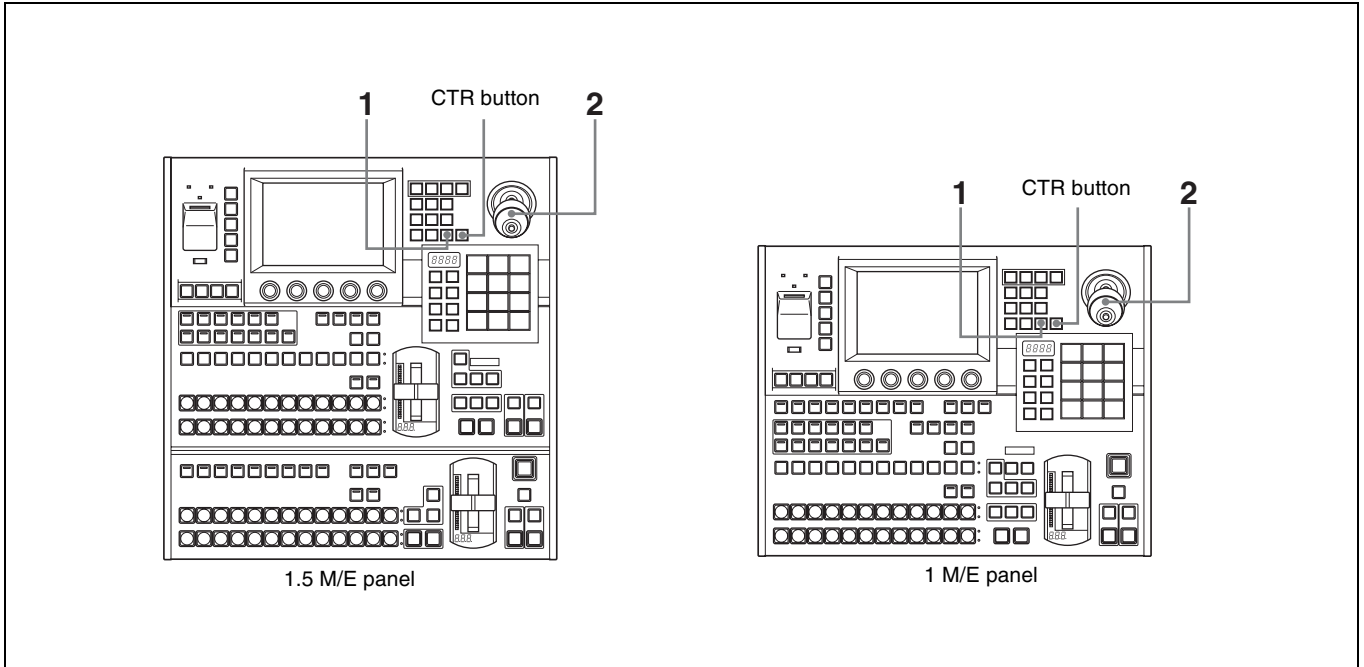

- 1** Press the [POS] button in the Effect/Wipe control block, lighting it.

The joystick is assigned to the positioner (which changes effect pattern position and size).
- 2** For a 2-channel effect, select the channel or channels for which you want to make settings. (See “To select channels with the Effect/Wipe control block” (page 68).)

(You can set the parameters for the individual channels.)
- 3** Operate the joystick as shown below, depending on what you want to change.

Holding down the button in the top of the joystick while operating it reduces the degree of change caused by the operation, to allow finer control. (Fine mode)

Joystick direction	Description	Setting values
X (H Position)	Horizontal position	-200.00 to +200.00
Y (V Position)	Vertical position	-200.00 to +200.00
Knob (Size) <sup>a)</sup>	Effect pattern size	0.00 to 200.00

a) Not available for some patterns. For details, refer to “Effect Pattern Transformations and Modifications” in the Appendix (separate document).

### To return the pattern size and position to their default

Press the [CTR] button in the Effect/Wipe control block.

# Changing Pattern Size and Position From Menus

- 1 From the top menu, select Effect/Wipe >M/E Effect >Main.

The Main menu appears.

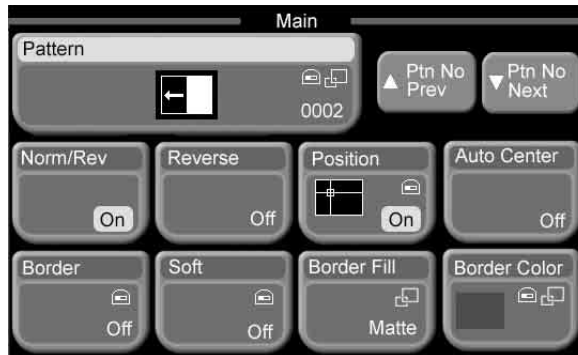

- 2 Press [Position], turning it on.
- 3 For a 2-channel effect, select the channel or channels for which you want to make settings. (See “To select channels from menus” (page 68).)  
(You can set the parameters for the individual channels.)
- 4 Set the following parameters with the knobs.

Knob	Description	Setting values
1 (H Position)	Horizontal position	-200.00 to +200.00 <sup>a)</sup>
2 (V Position)	Vertical position	-200.00 to +200.00 <sup>b)</sup>
3 (Size) <sup>c)</sup>	Effect pattern size	0.00 to 200.00

a) -100.00 moves the center of the pattern to the left edge, and +100.00 moves it to the right edge.  
 b) -100.00 moves the center of the pattern to the bottom edge, and +100.00 moves it to the top edge.  
 c) Not available for some patterns. For details, refer to “Effect Pattern Transformations and Modifications” in the Appendix (separate document).

### To return the pattern to the center of the screen in a transition (effect pattern nos. 0001 to 0999 only)

In the Effect/Wipe >M/E Effect >Main menu, press [Auto Center], turning it on.

# Modifying Video Borders

You can add borders to the edges of the video, and soften the borders or edges (see following figure).

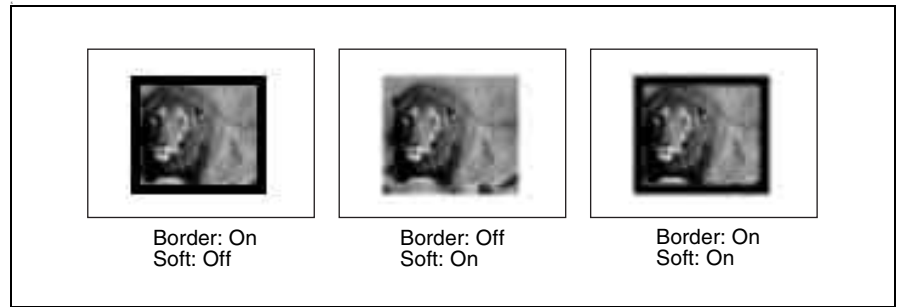

## Flow of Operations

The following figure shows a typical flow of operations when using the MFS-2000 system. For details about operations, see the pages in parentheses ( ).

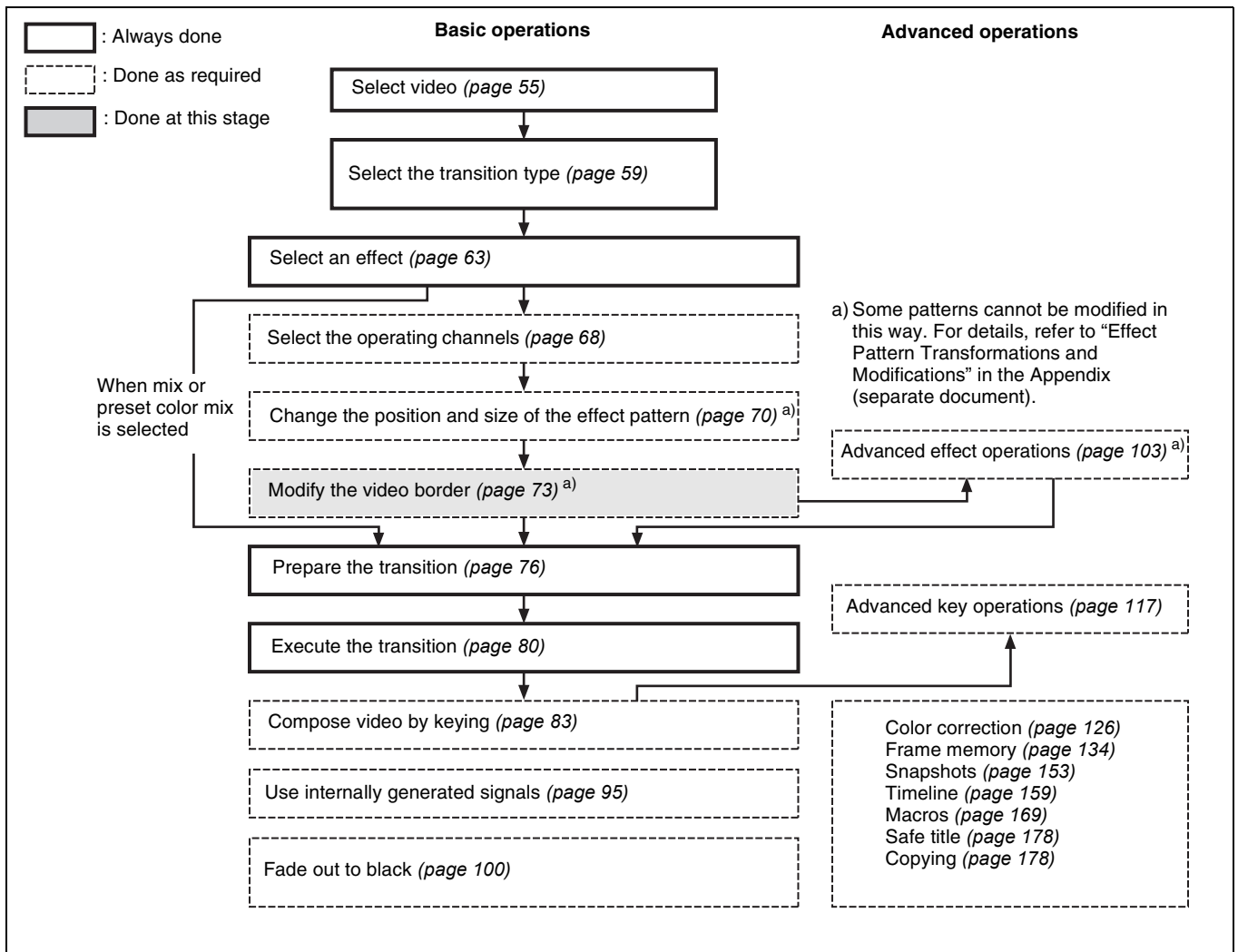

# Adding Borders to Video

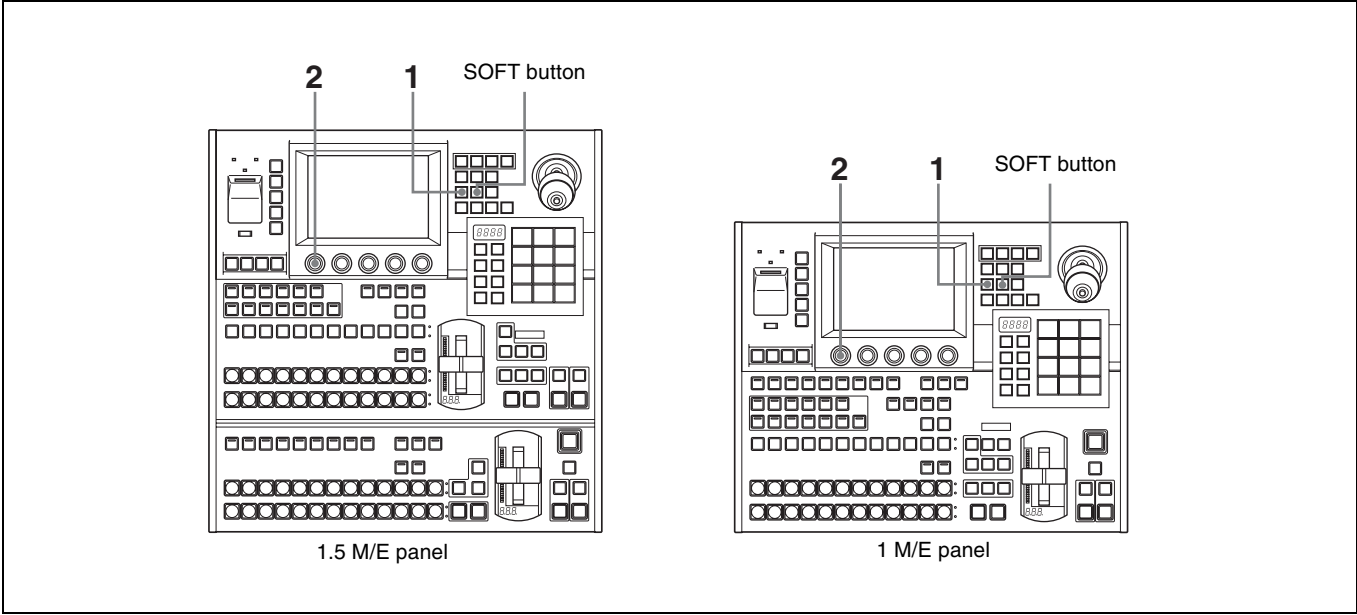

- 1** Press the [BORD] button in the Effect/Wipe control block, lighting it. Or, turn [Border] on in the Effect/Wipe >M/E Effect >Main menu (*see page 65*).
- 2** Set the following parameter with knob 1.

Knob	Description	Setting values
1 (Width)	Width of border	0.00 to 100.00

## To set border colors

- 1** For a 2-channel effect, in the Effect >Wipe >M/E Effect >Main menu (*see page 68*), select the channel or channels for which you want to make settings.

(You can set parameters for the individual channels.)

Note that for effects other than 2-channel effects, it is not necessary to carry out channel selection. Begin with step **2**.

- 2** Press [Border Color].

A popup window appears, displaying the same 8 colors as a color bar.

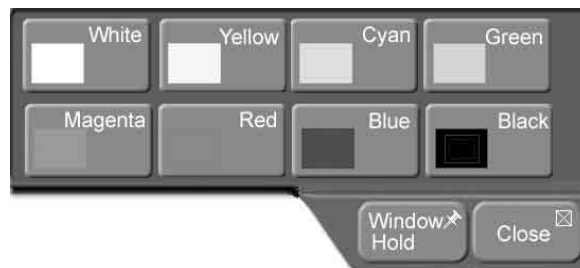

- 3 Press the button for the color that is closest to the desired color.  
The popup window closes.
- 4 Set the following parameters with the knobs.

Knob	Description	Setting values
1 (Lum)	Luminance	0.00 to 100.00
2 (Sat)	Saturation	0.00 to 100.00
3 (Hue)	Hue	359.99 to 0.00

---

## Softening Video Edges (Soft Edge/Soft Border)

- 1 Press the [SOFT] button in the Effect/Wipe control block, lighting it.  
Or, turn [Soft] on in the Effect/Wipe >M/E Effect >Main menu.
- 2 Set the following parameters with the knobs.

### No borders:

Knob	Description	Setting values
1 (Soft)	Softness of edges	0.00 to 100.00

### Borders:

Knob	Description	Setting values
1 (Width)	Width of borders	0.00 to 100.00
2 (Inner Soft)	Softness of border inner side	0.00 to 100.00
3 (Outer Soft)	Softness of border outer side	0.00 to 100.00 <sup>a)</sup>

a) Not displayed for effect patterns nos.1001 to 2999.

# Preparing Transitions

## Flow of Operations

The following figure shows a typical flow of operations when using the MFS-2000 system. For details about operations, see the pages in parentheses ( ).

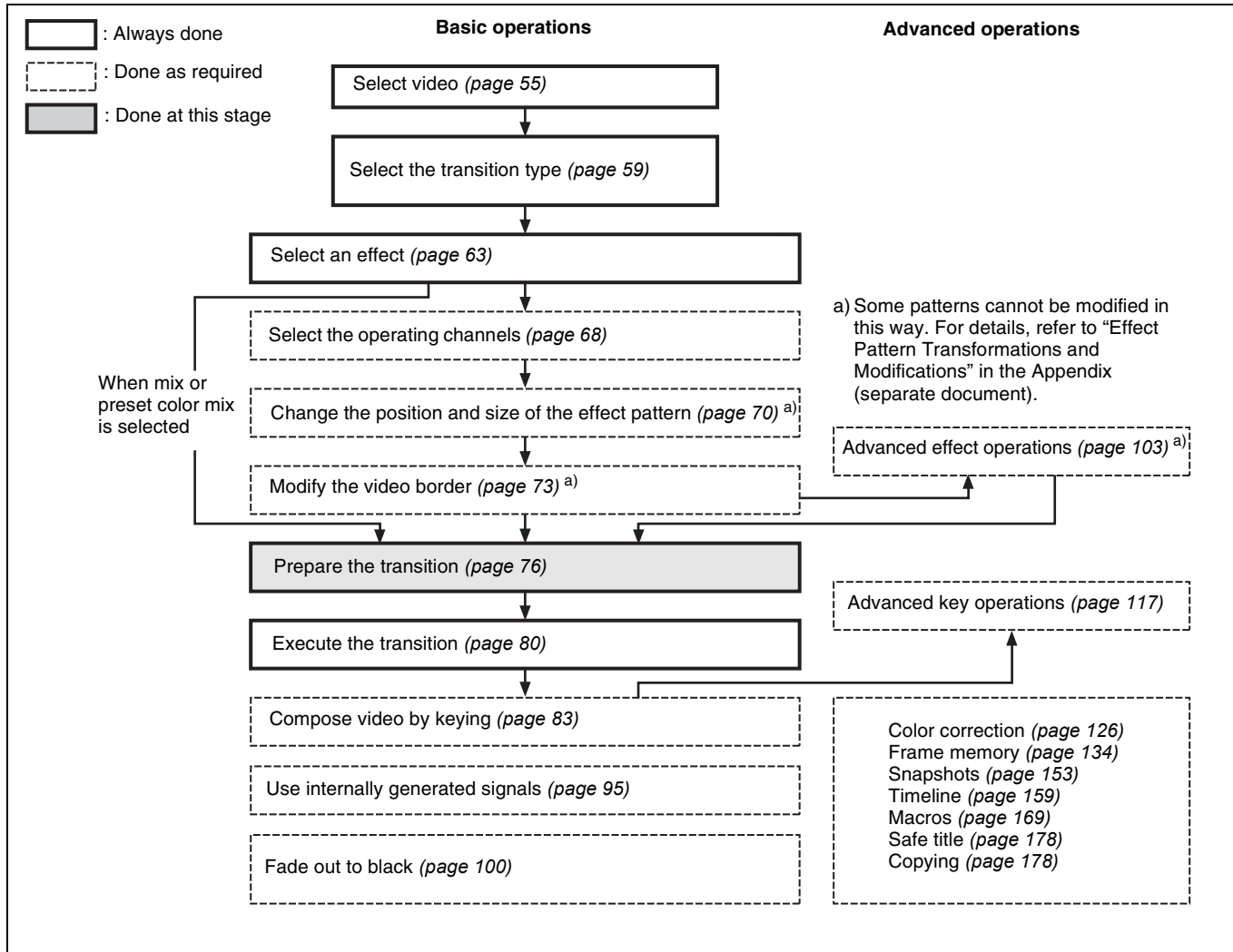

## Setting Transition Rates

For a transition which is executed automatically over a specified duration, you need to set the duration (transition rate). To set transition rates, you can use either the Flexi Pad control block or menus.

**Note**

When a clip transition is selected as the transition type, it is not possible to set the transition rate. In this case, transition rate depends on the background transition rate setting in the Clip Transition menu and the duration of the clip.

## To set transition rates with the Flexi Pad control block

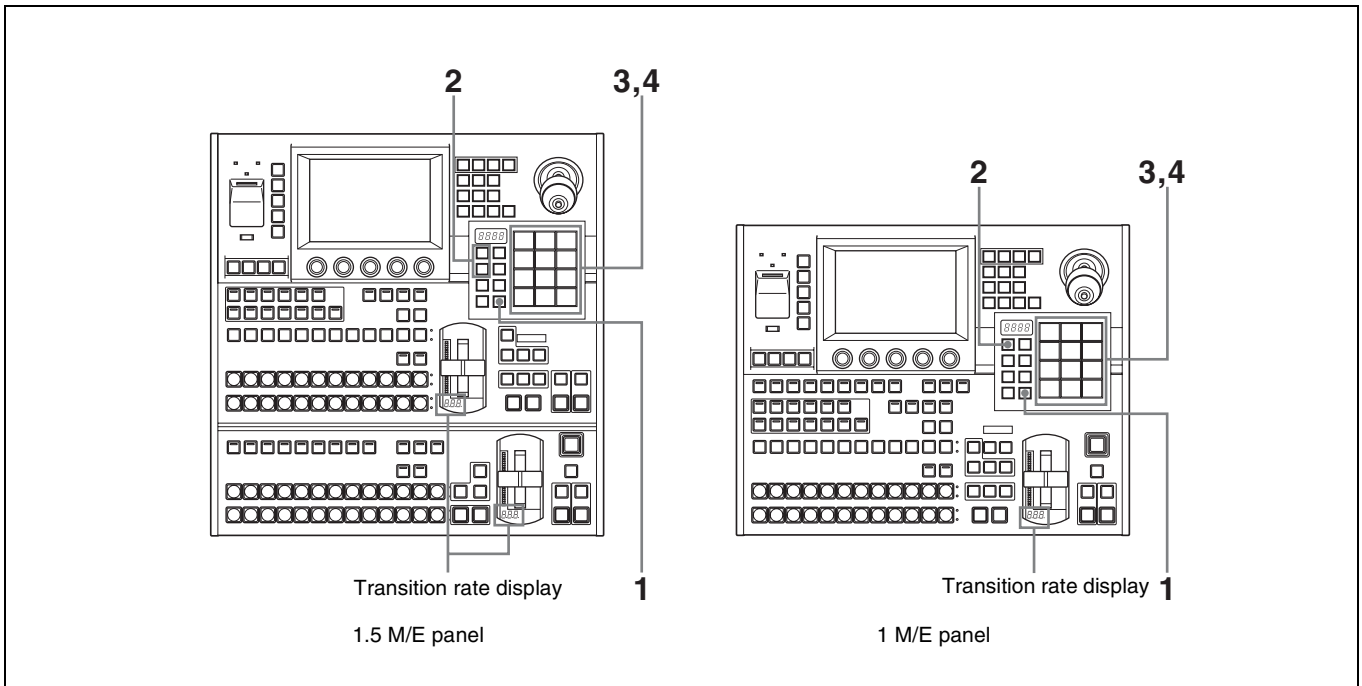

**1** In the Flexi Pad control block, press the [TRANS RATE] mode selection button, lighting it.

The Flexi Pad control block enters transition rate input mode.

**2** Select the target of the setting with the delegation selection buttons.

- Press [ME/RGN] to set for the M/E bank.
- Press [PP/ALL] to set for the PGM/PST bank (when using the 1.5M/E panel).

**3** Enter the transition rate as a number of frames. (The setting range is 0 to 999.)

**4** Press the [ENTR] button.

This confirms the input. The transition rate appears beneath the fader lever in the transition control block.

## To set transition rates from menus

**1** From the top menu, select Misc >Transition.

The Transition menu appears.



- 2** Select the target of the setting.
  - Press [M/E] to set for the M/E bank.
  - Press [P/P] to set for the PGM/PST bank (when using the 1.5M/E panel).

The numeric keypad window appears.

- 3** Enter a number of frames in the range 0 to 999 and press [Enter].

This confirms the input. The transition rate appears beneath the fader lever in the transition control block.

## Selecting Effect Directions

You can select the direction of some effects. The normal direction is the direction of the arrows shown in the illustrations of effect patterns in the “Effect Pattern List” in the Appendix (separate document). The reverse direction is the opposite direction.

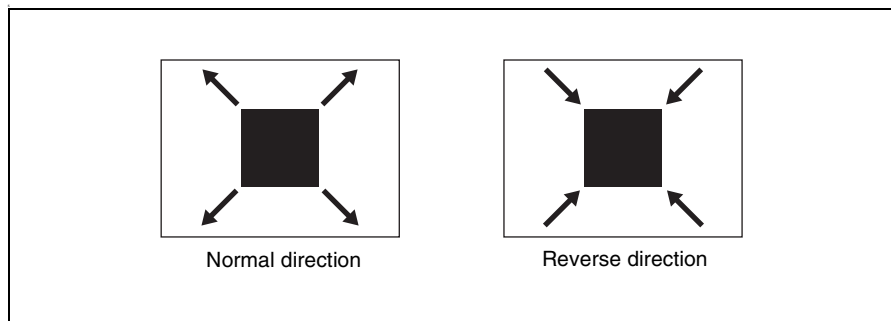

To select effect directions, you can use either the Effect/Wipe control block or menus.

## To select effect directions with the Effect/Wipe control block

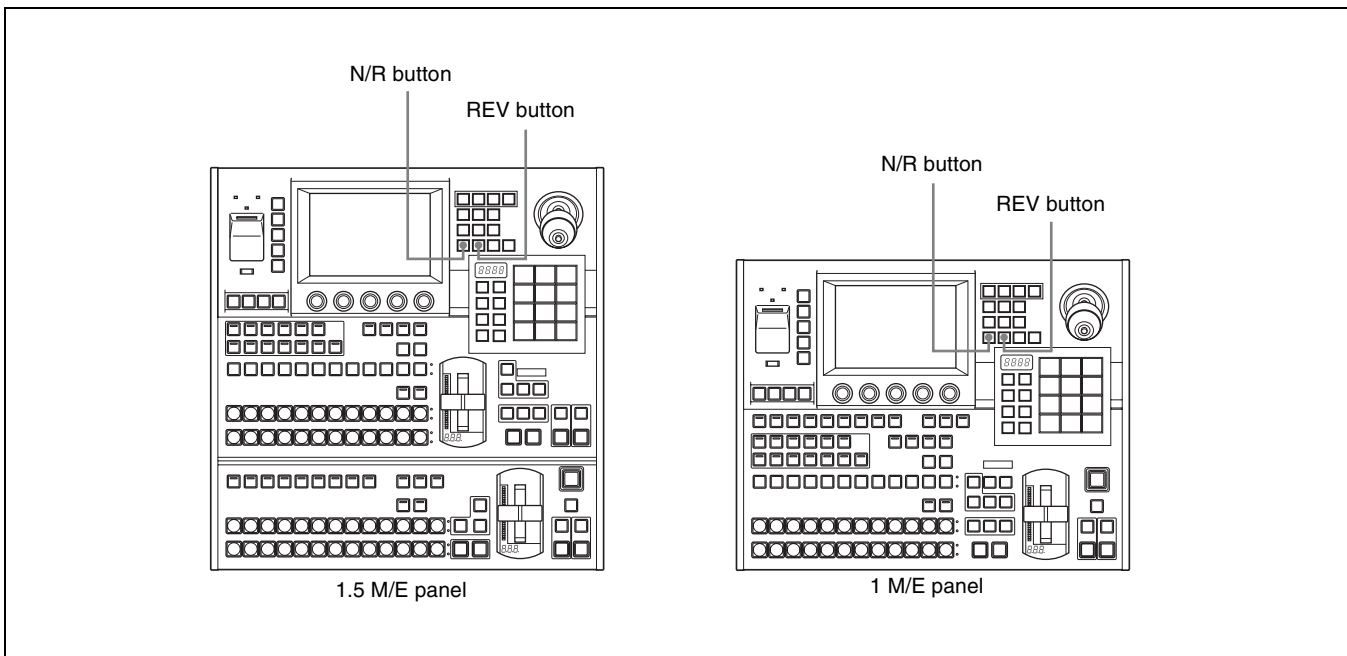

**To select the normal direction:** Turn both the [REV] button and [N/R] button off, so that they are not lit.

**To select the reverse direction:** Press the [REV] button so that it lights, and the [N/R] button so that it is not lit.

**To select the normal/reverse direction:** Press the [N/R] button so that it lights.

## To select effect directions from menus

- 1 From the top menu, select Effect/Wipe >M/E Effect >Main.

The Main menu appears.

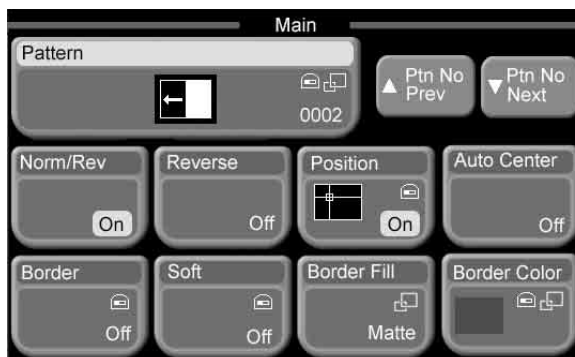

- 2 Select one of the following.

**To select the normal direction:** Turn both [Norm/Rev] and [Reverse] off.

**To select the reverse direction:** Turn [Reverse] on, and turn [Norm/Rev] off.

**To select the normal/reverse direction:** Turn [Norm/Rev] on.

# Executing Transitions

## Flow of Operations

The following figure shows a typical flow of operations when using the MFS-2000 system. For details about operations, see the pages in parentheses ( ).

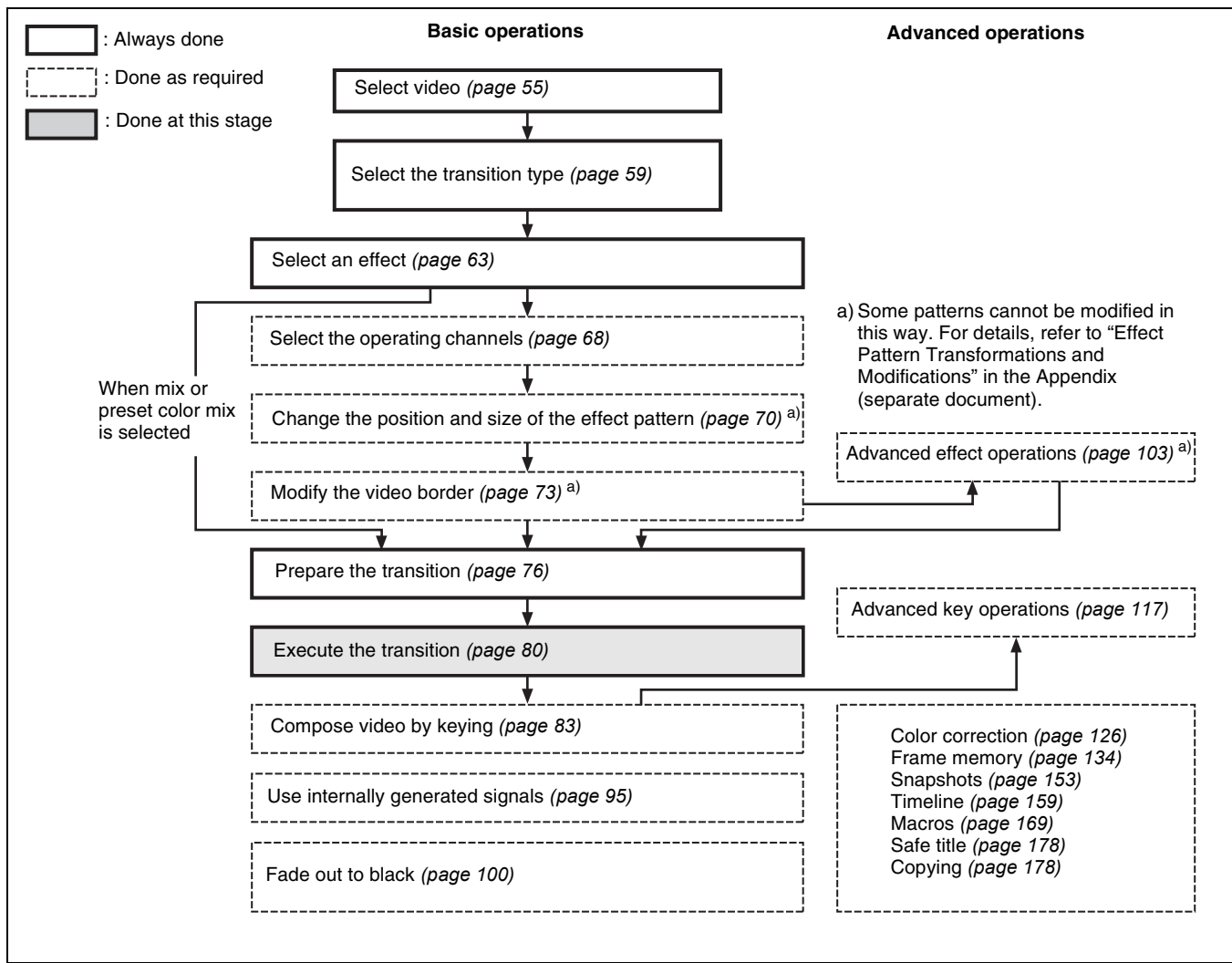

## Executing Transitions

Execute transition with the buttons and levers shown in the following figure.

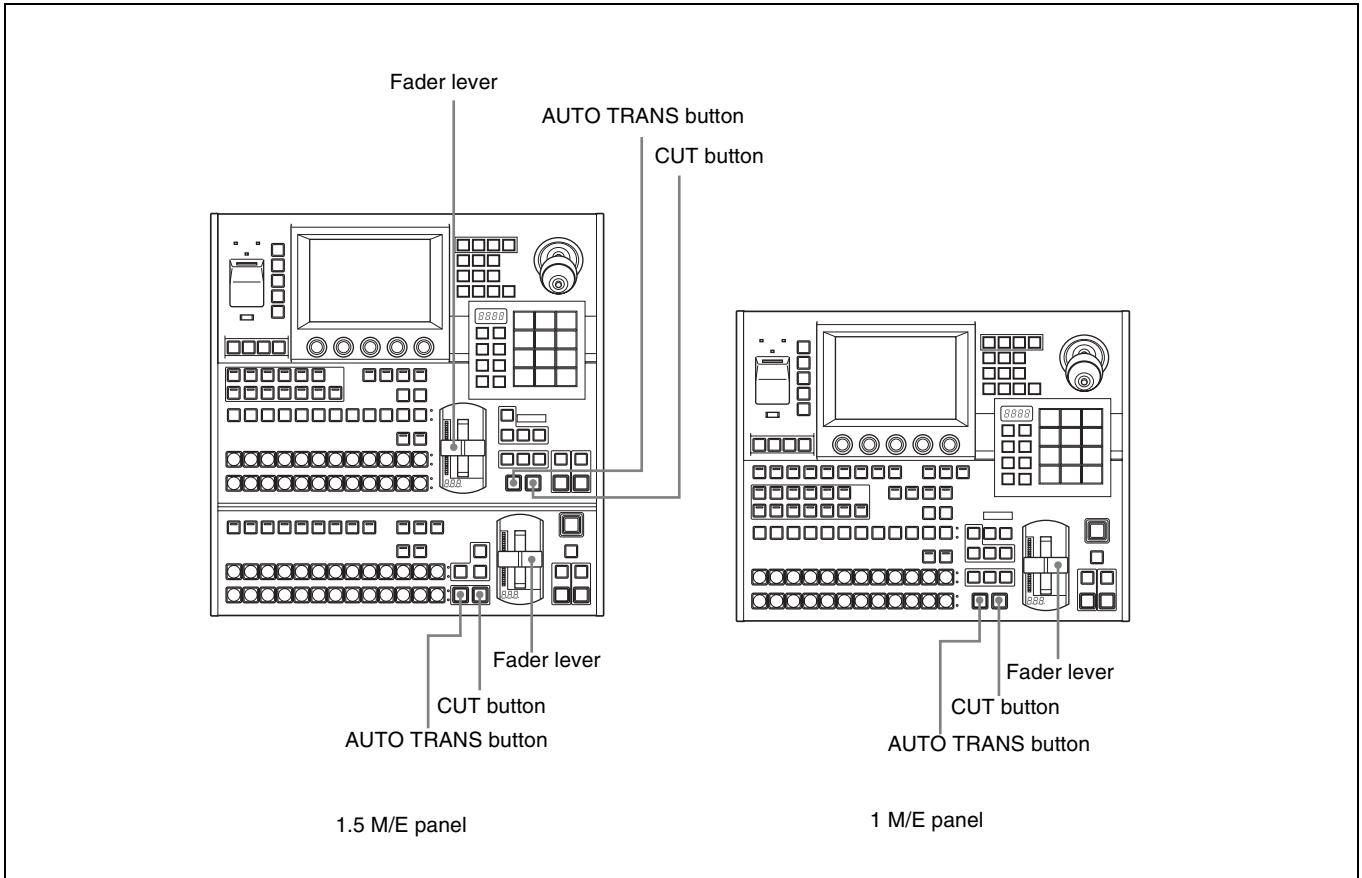
**Note**

When modifications (Position, Aspect, and so on) have been applied to effects, the video may not switch smoothly, and afterimages may remain visible even after transitions have finished executing.

**To switch the video instantly ([CUT] button)**

Press the [CUT] button in the transition execution section.

The video switches between the A bus and the B bus with each press of the button.

**To execute a transition at a specified transition rate ([AUTO TRANS] button)**

Press the [AUTO TRANS] button in the transition execution section.

The progress of the transition is shown by the transition indicator LEDs, which light one after the other as the transition proceeds.

**To execute a transition with the fader lever**

Move the transition lever from one side to the other at any speed. Once you do this, you can control the transition manually.

The transition indicator LEDs light one after the other as you move the lever to execute the transition.

**About fader lever non-sync**

If an auto transition finishes with the fader lever in an intermediate position, the lever position does not match the current transition position. This state is called “non-sync”.

Two of the transition indicator LEDs light to indicate a non-sync state, either at the top of the lever range, at the bottom of the range, or at both sides.

- Moving the lever toward the side where LEDs are lit does not execute a transition. However, the non-sync state is released when the lever reaches the edge of its range, enabling you to execute a transition with the next operation.
- Moving the lever toward the side where LEDs are not lit executes a transition across the remaining lever range.

An auto transition is possible even if the fader lever is in a non-sync state. When you press the [AUTO TRANS] button, the transition indicator LEDs light as always to show the progress of the transition. But when the transition finishes, two of the LEDs light to indicate the non-sync state.



# Composing Video With Keys

A key is an effect in which color and shape information is used to cut out part of the background video and replace it with another color or other video. The signal determining how the background is cut out is termed the “key source”, and the signal that replaces the cut-out part is termed the “key fill”.

This system supports the following types of keys.

**Luminance key/linear key:** Used to insert titles and logos into the video. The key source often shows black and white text, which is detected by using the luminance (Y) signal.

**Chroma key:** Used to compose scenes with two different components, for example people and a background. A key signal based on a particular color is used to cut out the background.

**Pattern key:** Video is composed using various patterns. A special pattern is used as the key source.

## Flow of Operations

The following figure shows a typical flow of operations when using the MFS-2000 system. For details about operations, see the pages in parentheses ( ).

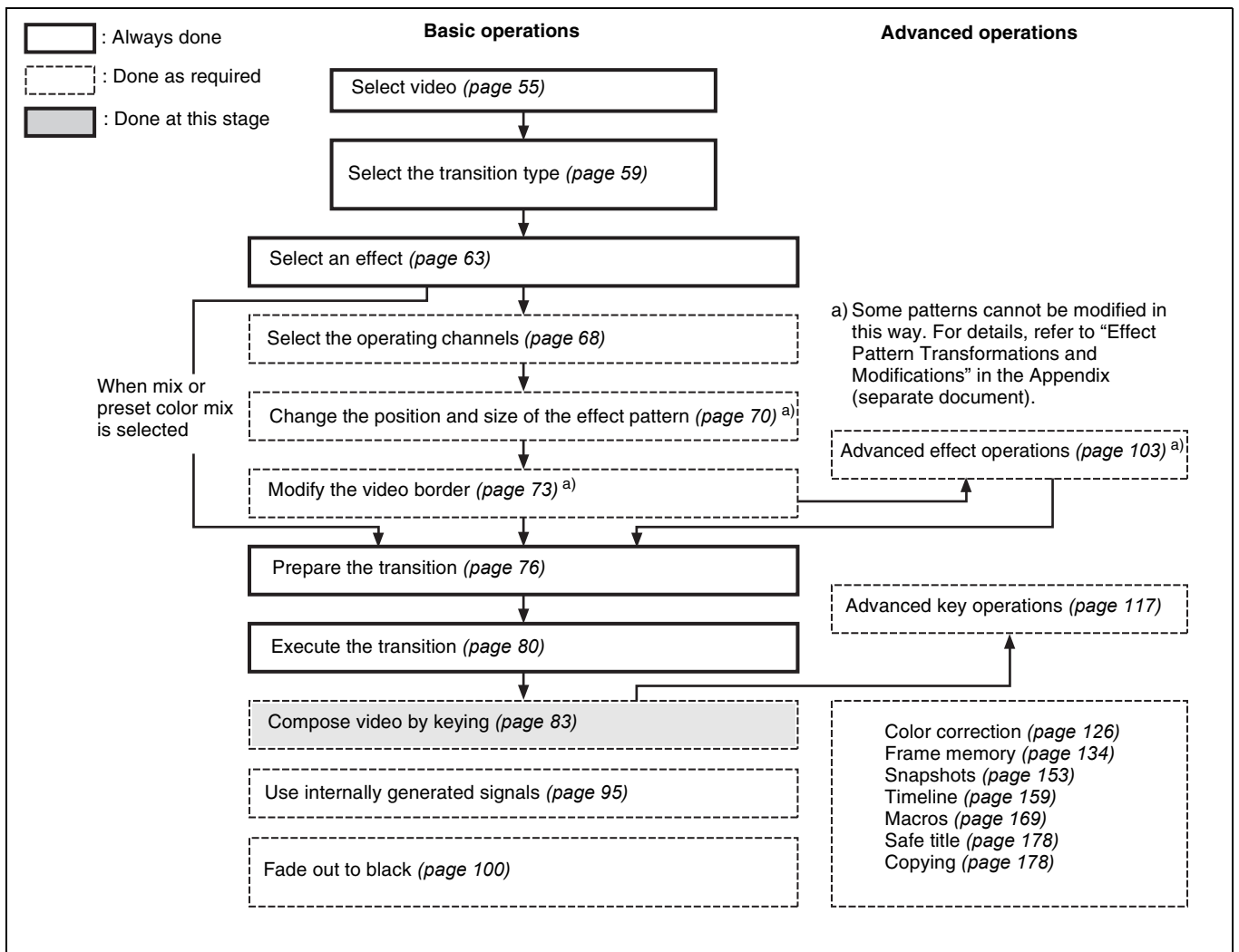

## M/E Keys and Downstream Keys

Two keys each are available on the M/E bank and the PGM/PST bank. The M/E bank keys are called key 1 and key 2, and the PGM/PST bank keys are called downstream key 1 and downstream key 2. The downstream keys are also abbreviated as DSK1 and DSK2.

## Inserting Text With a Luminance Key or Linear Key

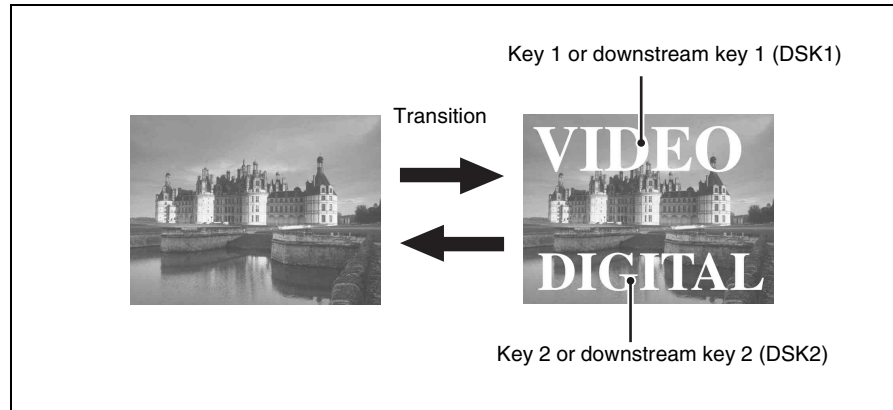

A linear key is a type of luminance key, but with less variation in gain, allowing more precise adjustment.

The following procedure shows how to set up key 1 on the M/E bank. The same operations can be used with the other keys as well (key 2, and downstream keys 1 and 2).

### To select luminance or linear key and set the key parameters

- 1 From the top menu, select Key >M/E Key1 >Main.

The Main menu appears.



- 2 Press [Key Type].

A popup window appears.



- 3 To select a luminance key, press [Luminance]. To select a linear key, press [Linear].

The popup window closes.

- 4 Set the following parameters with the knobs.

Knob	Description	Setting values
1 (Clip)	Reference level for key signal generation	+109.59 to -7.31
2 (Gain)	Gain of key	-100.00 to +100.00
3 (Density)	Density of key	0.00 to 100.00
4 (Filter)	Filter coefficient	1 to 9 <sup>a)</sup>

a) Set to 1 for through processing, with no filter applied. The filter becomes stronger as larger numbers are specified.

## To select a key source

- 1 In the Key >M/E Key1 >Main menu (*see page 84*), press [Key Source]. (The current key source name is displayed in the Main menu.)

A popup window appears.



- 2 Press one of the following to select the signal to be used as key source.

**Self:** Select the same signal as key fill.

**Auto Select:** Automatically select the key signal assigned to a cross-point button together with the key fill bus signal as a pair. (Use the Setup/Diag >Operation >V/K Pair Assign menu (*see page 207*) to carry out pair assignments.)

**Split:** Aside from the key source signal selected automatically in Auto Select mode, another key source may be selected independently. If you select this, proceed to step 3 and select the key source.

- 3 If you selected “Split” in step 2, press the [KEY1] button and the [SRC BUS] button in the AUX bus control block, lighting both buttons, and select a key source in the cross-point button row. The state of the [KEY] button determines whether the key side or the video side is selected. (*See the following figure.*)

- When you light the [SRC BUS] button, the [KEY] button also lights, enabling you to select the key side signal assigned as the key source to the pair number.

- Pressing the [KEY] button to turn it off enables you to select the video side signal assigned as the key source to the pair number.

The newly selected key source name is displayed in the Main menu.

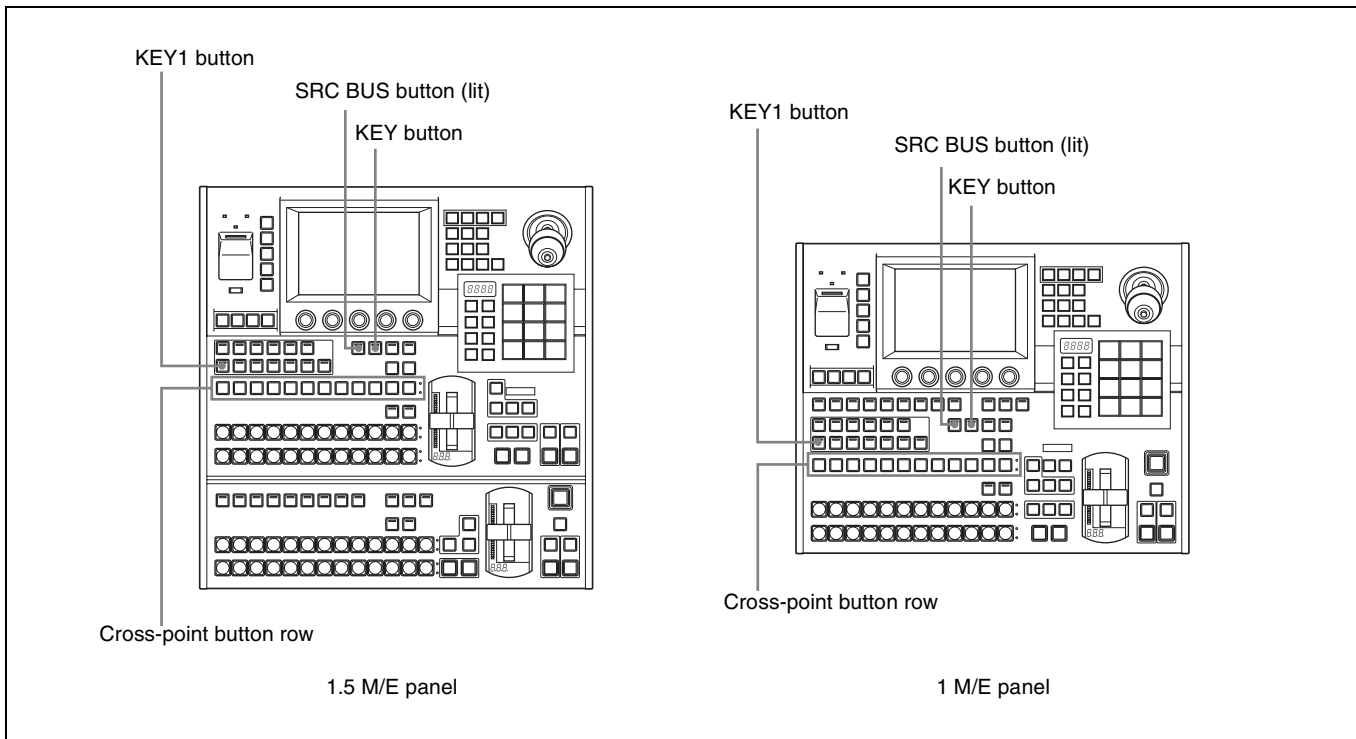

## To select a key fill

- 1 In the Key >M/E Key1 >Main menu (*see page 84*), press [Key Fill].  
(The current key fill name is displayed in the Main menu.)

A popup window appears.



- 2 Press one of the following.

**Key Bus:** Key fill bus signal selected in the AUX bus control block.

**Matte:** Signal generated by internal color matte signal generator. When this is selected, you can select the matte color as explained in the next section “To adjust the key fill color”.

- 3 If you selected “Key Bus” in step 2, first press the [KEY1] button in the AUX bus control block, lighting it, then press the [SRC BUS] button, extinguishing it, and finally select the key fill from the cross-point button row. (*See the following figure.*)

The newly selected key fill name is displayed in the Main menu.

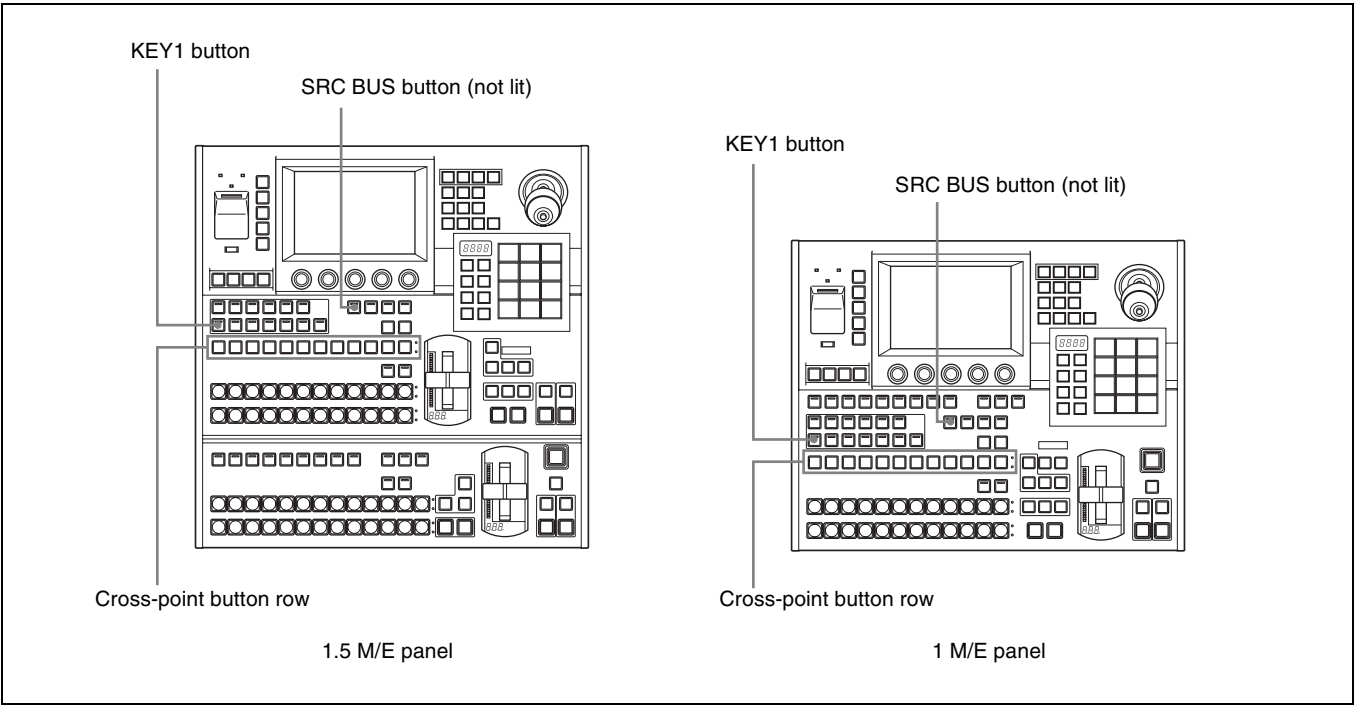

**To adjust the key fill color**

When you select “Matte” as the key fill, you can obtain the desired color with the following procedure.

- 1 In the Key >M/E Key1 >Main menu (*see page 84*), press [Fill Color].  
A popup window appears, displaying the same eight colors as a color bar.

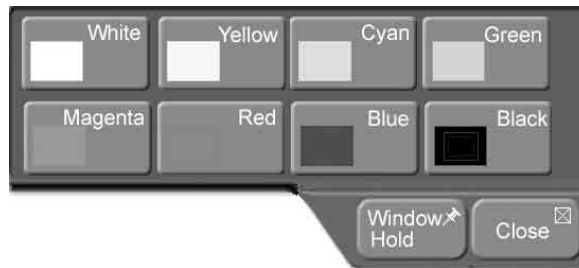

- 2 Press the button for the color that is closest to the desired color.  
The popup window closes.
- 3 Set the following parameters with the knobs.

Knob	Description	Setting values
1 (Lum)	Luminance	0.00 to 100.00
2 (Sat)	Saturation	0.00 to 100.00
3 (Hue)	Hue	359.99 to 0.00

**To insert and delete keys**

Use transitions to insert keys into background video and to delete keys from background video.

For more information about key transitions, see “To select the next transition” (page 62), “Preparing Transitions” (page 76), and “Inserting and Deleting Keys Only” (page 93).

## Composing Video With Chroma Keys

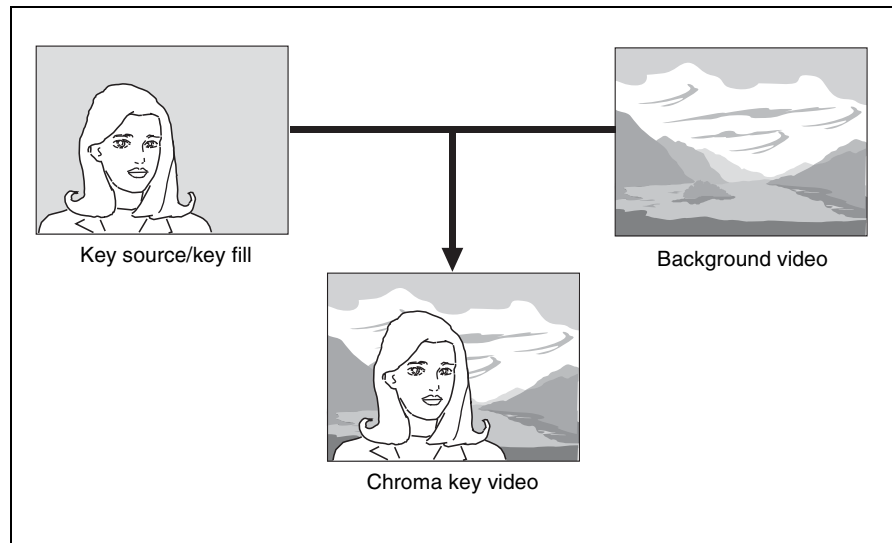

### To select chroma key

The following procedure shows how to set up key 1 on the M/E bank. The same operations can be used to set up the other keys as well (key 2, and downstream keys 1 and 2).

- 1** In the Key >M/E Key1 >Main menu (see page 84), press [Key Type].  
A popup window appears (see page 84).
- 2** Press [Chroma].

### To select a chroma key source

Refer to step **1** in “To select a key source” (page 85) in the procedure for luminance and linear keys.

### To select a chroma key fill

Referring to the procedure for luminance and linear keys in “To select a key fill” (page 86), set the key fill to “Key Bus”, and select the key fill with the cross-point buttons.

### To adjust auto chroma key

- 1** In the Key >M/E Key1 >Main menu (see page 84), press [Auto CRK], turning it on.  
A square frame sample mark appears in the external monitor screen. Also, the key source is set automatically to “Self”.
- 2** Adjust the following parameters so that the chroma key reference color (typically blue) is seen within the sample mark.

Knob	Description	Setting values
1 (H Position)	Move the sample mark horizontally.	-100.00 to +100.00 <sup>a)</sup>
2 (V Position)	Move the sample mark vertically.	-100.00 to +100.00 <sup>a)</sup>
3 (Size)	Adjust the size of the sample mark.	1.00 to 100.00

a) The setting range varies depending on the signal format, and screen aspect and size settings.

### 3 Press [Auto Start].

Auto chroma key is executed on the basis of the color inside the sample mark, and chroma key video is output to the monitor screen. [Auto CRK] is turned off automatically.

## To adjust chroma key video

### 1 In the Main menu (see page 84), press [Key Type].

### 2 Set the following parameters with the knobs.

Knob	Description	Setting values
1 (Clip)	Reference level for key signal generation	0.00 to 100.00
2 (Gain)	Gain of key	-100.00 to +100.00
3 (Hue)	Hue	359.99 to 0.00
4 (Density)	Density of key	0.00 to 100.00
5 (Filter)	Filter coefficient	1 to 9 <sup>a)</sup>

a) Set to 1 for through processing, with no filter applied. The filter becomes stronger as larger numbers are specified.

To make finer adjustments, see “Adjusting Chroma Keys” (page 118).

## Composing Video With Pattern Keys

### To select pattern key and set the key parameters

The following procedure shows how to set up key1 on the M/E bank. The same operations can be used to set up the other keys as well (key 2, and downstream keys 1 and 2).

### 1 In the Key >M/E Key1 >Main menu (see page 84), press [Key Type].

A popup window appears (see page 85).

### 2 Press [Pattern].

### 3 Set the following parameters with the knobs.

Knob	Description	Setting values
1 (Size)	Size of pattern	0.00 to 100.00
2 (Soft)	Softness of edges	0.00 to 100.00
3 (Density)	Density of key	0.00 to 100.00
4 (Pattern)	Pattern number	1 to 24 <sup>a)</sup>

a) Same as standard wipes.

## About the pattern key source

In the pattern key, a wipe pattern is selected automatically as the key source. No user operation is required.

## To select the key fill for a pattern key

As the key fill, “Key Bus” and “Matte” can be selected. (See “To select a key fill” (page 86)).

## To transform the pattern used in a pattern key

See “Transforming the Pattern of a Pattern Key” (page 121).

---

## Adding Borders to Keys

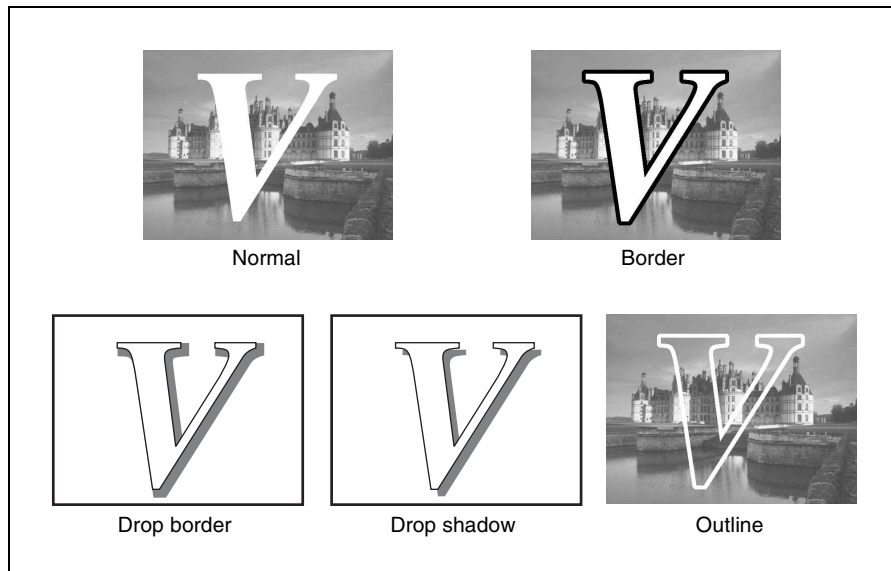

The following procedure shows how to add borders to key1 on the M/E bank. The same operations can be used to add borders to the other keys as well (key 2, and downstream keys 1 and 2).

- 1 In the Key >M/E Key1 >Main menu (see page 84), press [Edge].

A popup window appears.



- 2 Press one of the following.

**Normal:** Do not add anything to the edges.

**Border:** Add a border to the edges.

**Drop Border:** Add a drop border to the edges.

**Shadow:** Add a shadow to the edges.

**Outline:** Add an outline to the edges.

The popup window closes.

- 3 Set the following parameters, depending on what you selected in step 2.

**When Border or Outline was selected (with the separate edge function (see page 118) being off):**

Knob	Description	Setting values
1 (Width)	Width	0 to 8 <sup>a)</sup> (0.00 to 100.00) <sup>b)</sup>
2 (Density)	Density	0.00 to 100.00

a) 0 to 4 in 4H mode or when fine key (see page 117) is on.

b) When pattern key is selected as the key type.

**When Border or Outline was selected (with the separate edge function (see page 118) being on):**

Knob	Description	Setting values
1 (Left)	Left edge position	0 to 8 <sup>a)</sup>
2 (Right)	Right edge position	0 to 8 <sup>a)</sup>
3 (Top)	Top edge position	0 to 8 <sup>a)</sup>
4 (Bottom)	Bottom edge position	0 to 8 <sup>a)</sup>
5 (Density)	Key density	0.00 to 100.00

a) 0 to 4 in 4H mode or when fine key (see page 117) is on.

**When Drop Border or Shadow was selected:**

Knob	Description	Setting values
1 (Width)	Width	0 to 8 <sup>a)</sup>
2 (Position)	Position	1 to 3 <sup>b)</sup>
3 (Density)	Density	0.00 to 100.00

a) 0 to 4 in 4H mode or when fine key (see page 117) is on.

b) 1 to 8 when fine key (see page 117) is on.

### To add color to the key edges

- 1 From the top menu, select Key >M/E Key1 >Main, and press [Edge Color].

A popup window appears.

- 2 Press the button for the color that is closest to the desired color, and adjust the parameters with the knobs.

See “To adjust the key fill color” (page 87) for the parameters.

---

## Masking Part of a Key

A mask is used to cover part of the video with background or a key. This allows you to correct for unwanted holes in the background or a key that is not cut out in the desired way.

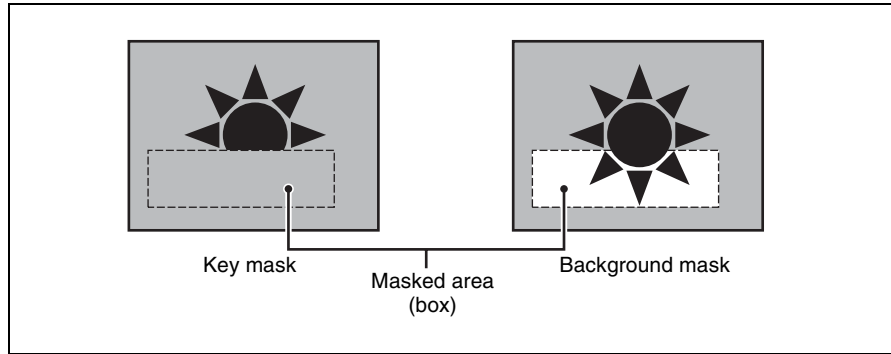

- 1 In the Key >M/E Key1 >Main menu (*see page 84*), press [Mask].

A popup window appears.



- 2 Press one of the following.

**Off:** Do not mask.

**Key Mask:** This masks out a part of the key, which will result in the background appearing.

**Bkgd Mask:** This masks out a part of the background, which will result in the key fill appearing.

The popup window closes.

*To make detailed mask settings, see “Setting Key Mask Shapes and Positions” (page 121).*

---

## Moving a Key Over or Under

### To check whether a key is over or under

There are OVER indicators in the M/E transition control block, located over key1 and key2. The key whose OVER indicator is lit is the key on top.

### To move a key over or under from menus

The following procedure shows how to move key1 on the M/E bank. The same operations can be used to move the other keys as well (key 2, and downstream keys 1 and 2).

- 1 In the Key >M/E Key1 >Main menu (*see page 84*), press [Key Priority].

A popup window appears.

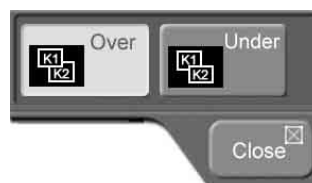

**2** Press one of the following.

**Over:** The target key is moved to over.

**Under:** The target key is moved to under.

### To move keys over and under in a transition

There is a [KEY PRIOR] button in the M/E transition control block.

Execute a transition after lighting this button as the next transition (*see page 62*).

The over/under relationship of key 1 and key 2 is reversed.

---

## Inserting and Deleting Keys Only

### To insert or delete a key by mixing (independent key transition)

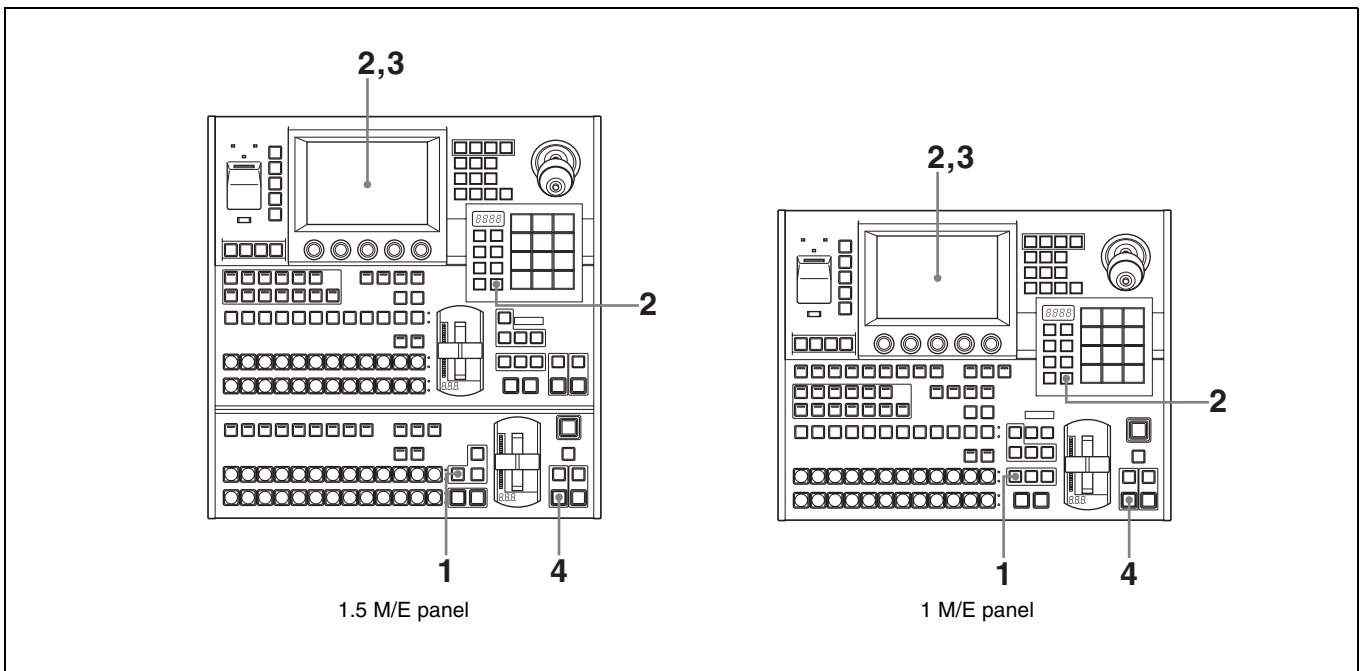

The following procedure shows how to set up downstream key 1. The same operations can be used to set up the other keys as well (M/E keys 1 and 2, and downstream key 2).

**1** From the top menu, select Key >M/E K1 Trans >Main.

The Main menu appears.

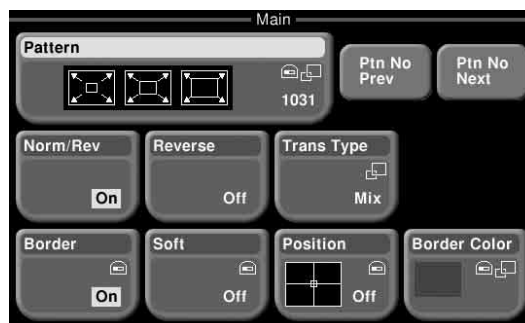

**2** Press [Trans Type].

A popup window appears.

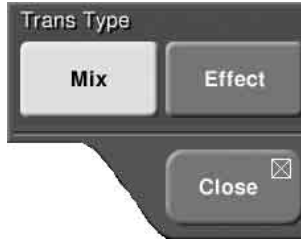

**3** Press [Mix].

The popup window closes, and the transition type of the independent key transition is set to “mix.”

**4** From the top menu, select Misc >Transition.

The Transition menu appears (*see page 60*).

**5** After pressing [DSK1], enter the key’s transition rate in the numeric keypad window. (*See “Setting Transition Rates” (page 76)*).

**6** In the downstream key/fade to black control block, press the [AUTO TRANS] button for DSK1.

Downstream key 1 is inserted, mixing into the background. If downstream key 1 is already inserted, it is deleted.

## To insert or delete keys instantly

### To insert or delete downstream keys instantly

In the downstream key/fade to black control block, press the [DSK1 ON] button or the [DSK2 ON] button.

### To insert or delete M/E keys instantly

If you are using the 1.5M/E panel, press the [KEY1 ON] button or the [KEY2 ON] button in the M/E key transition control block.

If you are using the 1 M/E panel, press the [KEY1 ON] button or the [KEY2 ON] button in the M/E transition control block.

# Using Internally Generated Signals

## Flow of Operations

The following figure shows a typical flow of operations when using the MFS-2000 system. For details about operations, see the pages in parentheses ( ).

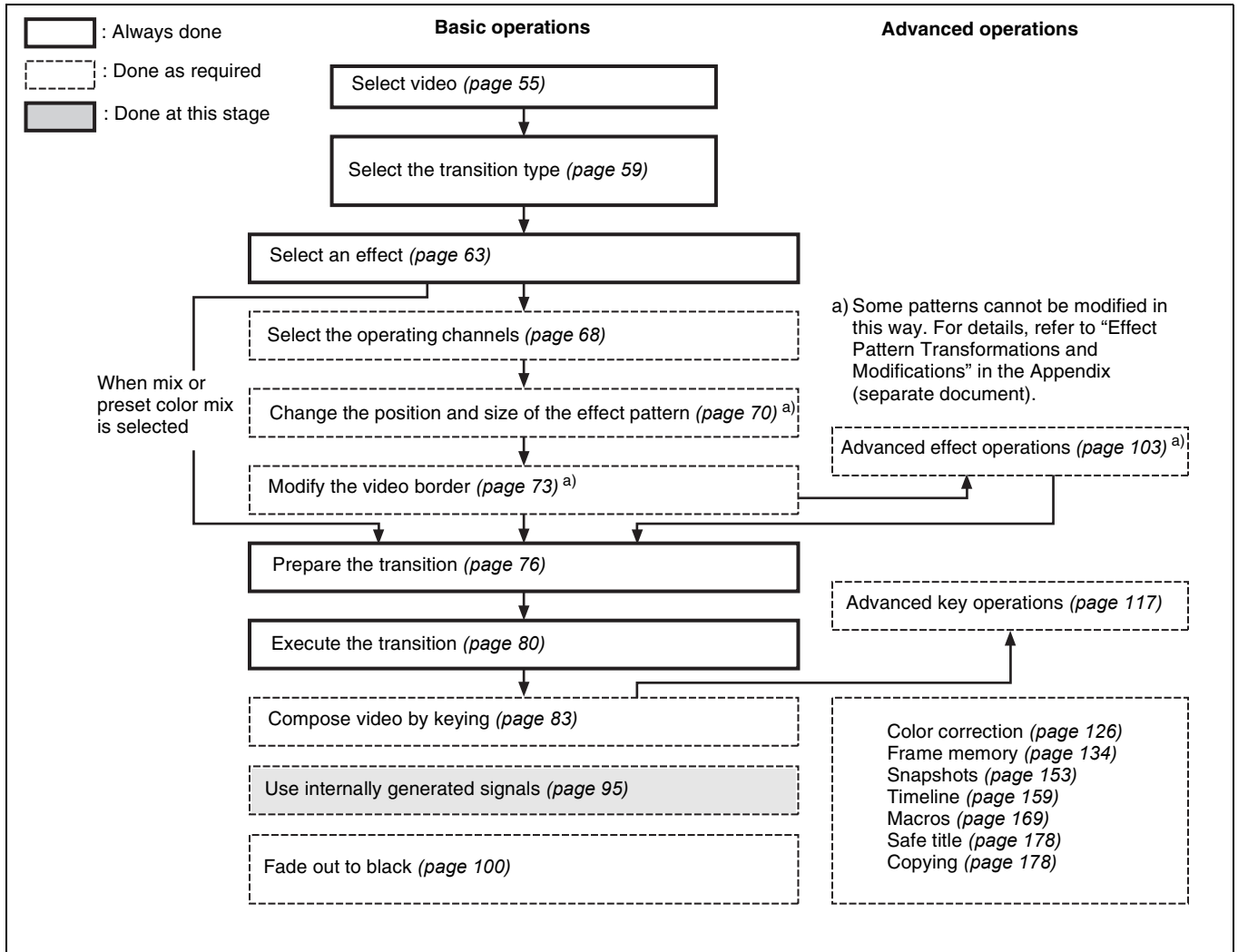

## Using a Color Background

The term “color background” refers to a signal generated by the processor’s internal color generator. The color can be either monotone or composed from two colors.

### To set color 1

- 1 From the top menu, select Misc >Color Bkgd.

The Color Bkgd menu appears.

The [Color1] button shows the current color.

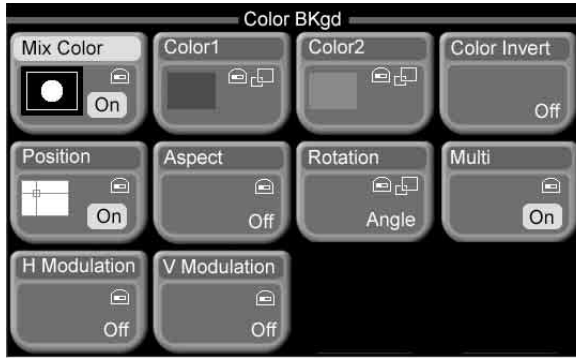

- 2 Press [Color1].  
A popup window appears.
- 3 Press the button for the color that is closest to the desired color.
- 4 Set the following parameters with the knobs.

Knob	Description	Setting values
1 (Lum)	Luminance	0.00 to 100.00
2 (Sat)	Saturation	0.00 to 100.00
3 (Hue)	Hue	359.99 to 0.00

### To compose a pattern of two colors (color mix)

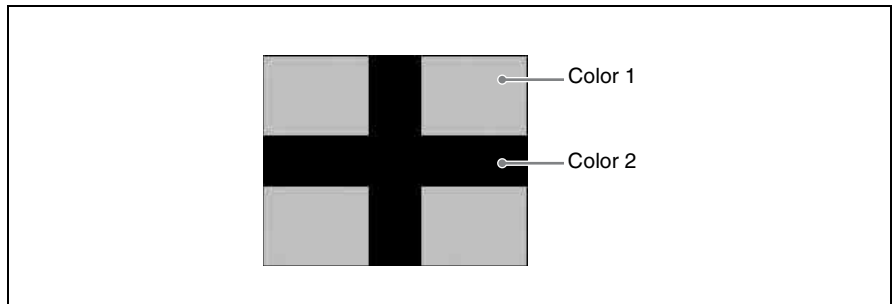

- 1 From the top menu, select Misc >Color Bkgd, then press [Mix Color], turning it on.
- 2 Compose the pattern by using the knobs to set the following parameters.

Knob	Description	Setting values
1 (Size)	Size of pattern	0.00 to 100.00
2 (Soft)	Softness of edges	0.00 to 100.00
3 (Pattern)	Pattern number	1 to 24 <sup>a)</sup>

a) Same as patterns in the standard group.

- 3 Press [Color1]. In the popup window which appears, press the button for the color that is closest to the desired color. Then set the parameters with the knobs. (See steps 3 and 4 of “To set color 1” (page 96)).
- 4 Press [Color2] and repeat the procedure.

## To transform color mix patterns

### To set the pattern position

- 1 From the top menu, select Misc >Color Bkgd, then press [Position], turning it on.
- 2 Adjust the following parameters with the knobs.

Knob	Description	Setting values
1 (H Position)	Move the pattern horizontally	-200.00 to +200.00 <sup>a)</sup>
2 (V Position)	Move the pattern vertically	-200.00 to +200.00 <sup>a)</sup>

- a) Minus values move the pattern to the left, and plus values move it to the right. At -100.00 the horizontal center is at the left edge of the screen. At +100.00, it is at the right edge.
- b) Minus values move the pattern down, and plus values move it up. At -100.00 the vertical center is at the bottom edge of the screen. At +100.00, it is at the top edge.

### To arrange multiple examples of the same pattern

- 1 From the top menu, select Misc >Color Bkgd, then press [Multi], turning it on.
- 2 Adjust the following parameters with the knobs.

Knob	Description	Setting values
1 (H Multi)	Number of patterns arranged horizontally	1 to 63
2 (V Multi)	Number of patterns arranged vertically	1 to 63
3 (Invert Type)	How patterns are arranged	1 to 4 (see figure below)

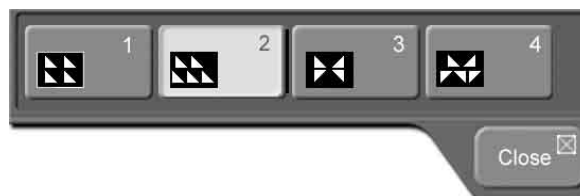

### To change the aspect ratio of a pattern

- 1 From the top menu, select Misc >Color Bkgd, then press [Aspect], turning it on.
- 2 Set the following parameter with knob 1.

Knob	Description	Setting values
1 (Aspect)	Aspect ratio of pattern	-100.00 to +100.00 <sup>a)</sup>

- a) Minus values make the pattern taller, and plus values make the pattern longer.

### To rotate an effect pattern

- 1 From the top menu, select Misc >Color Bkgd, then press [Rotation].  
A popup window appears.



- 2 Press [Angle].
- 3 Set the following parameter with knob 1.

Knob	Description	Setting values
1 (Angle)	Angle of pattern slant	-100.00 to +100.00 <sup>a)</sup>

a) -100.00 is one rotation in the counterclockwise direction, and +100.00 is one rotation in the clockwise direction.

### To rotate an effect pattern at a specified speed

- 1 From the top menu, select Misc >Color Bkgd, then press [Rotation].  
A popup window appears.
- 2 Press [Speed].
- 3 Set the following parameter with knob 1.

Knob	Description	Setting values
1 (Speed)	Speed of pattern rotation	-100.00 to +100.00 <sup>a)</sup>

a) -100.00 is one rotation per second in the counterclockwise direction, and +100.00 is one rotation per second in the clockwise direction.

### To modulate an effect pattern

#### Note

The shape of the modulation wave is fixed as a sin wave.

- 1 From the top menu, select Misc >Color Bkgd, then press [H Modulation] or [V Modulation], turning it on.  
  
H Modulation gives horizontal modulation, and V Modulation gives vertical modulation.
- 2 Adjust the following parameters with the knobs.

Knob	Description	Setting values
1 (Amplitude)	Amplitude of modulation wave	0.00 to 100.00
2 (Frequency)	Frequency of modulation wave	0.00 to 100.00
3 (Speed)	Speed of modulation	-100.00 to +100.00 <sup>a)</sup>

a) In H Modulation, maximum speed is at -100.00 in the left direction and +100.00 in the right direction.  
In V Modulation, maximum speed is at -100.00 in the downward direction and +100.00 in the upward direction.

## To exchange color 1 and color 2

From the top menu, select Misc >Color Bkgd, then press [Color Invert], turning it on.

The data for color 1 and color 2 are exchanged.



# Fading the Video to Black

Fade to black gradually darkens the overall video image, until it is completely black.

## Flow of Operations

The following figure shows a typical flow of operations when using the MFS-2000 system. For details about operations, see the pages in parentheses ( ).

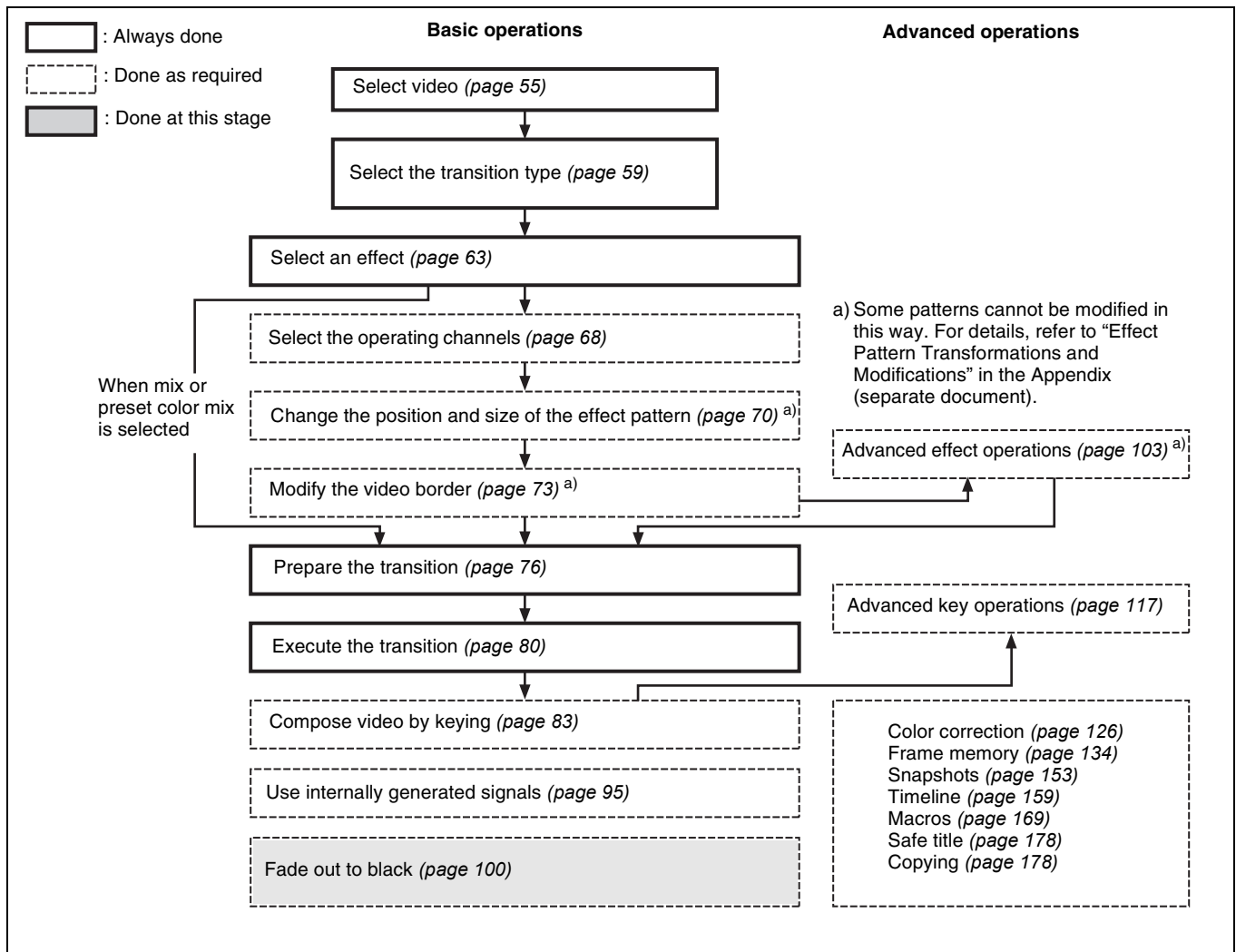

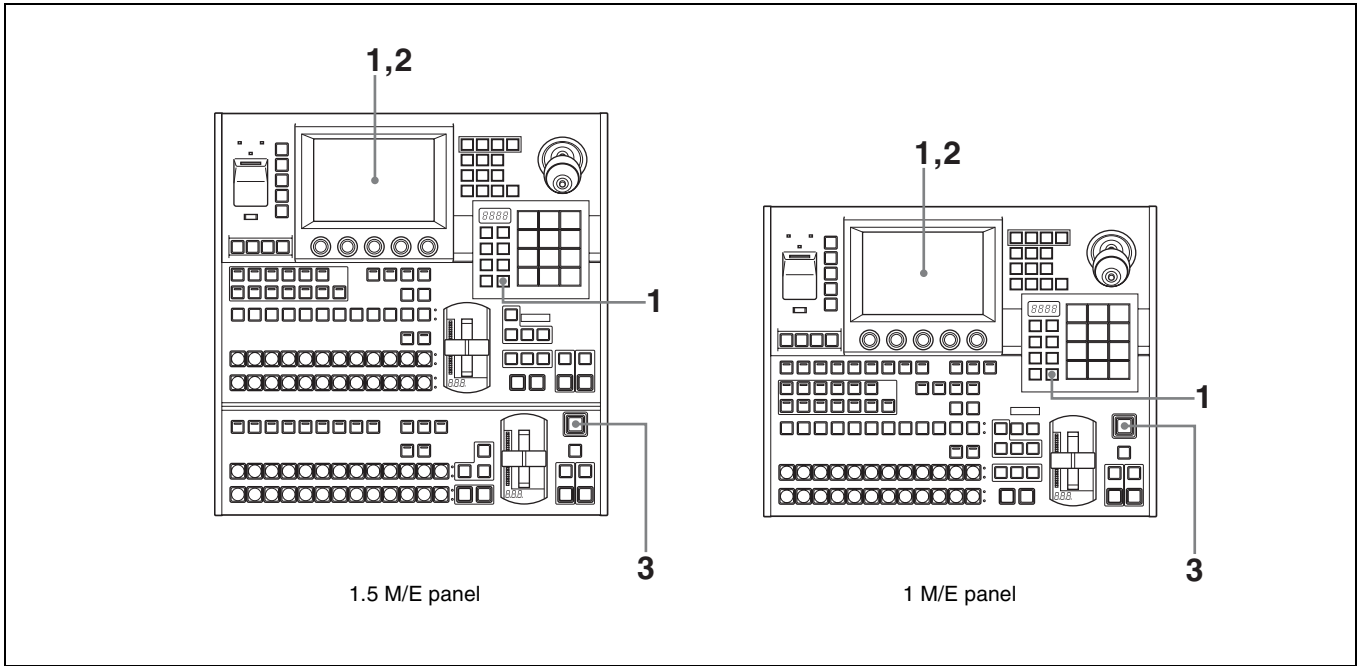

### To fade out the video with fade to black

- 1** From the top menu, select Misc >Transition.  
The Transition menu appears.
- 2** After pressing [FTB], enter a transition rate in the numeric keypad window.  
(See “Setting Transition Rates” (page 76)).
- 3** In the downstream key/fade to black control block, press the [FTB] button.  
The [FTB] button lights, and the fade to black begins. When it finishes, the picture is completely black.  
To stop the fade to black and return to the state before it started, press the button again.

### To return to the original video from a black screen

Press the [FTB] button again.



## Advanced Effect Operations

The procedures in this section mainly show how to operate with M/E effects (effects used on the M/E bank). The same procedures can also be used with PGM/PST wipes (wipes used on the PGM/PST bank).

### Transforming Effect Patterns

Note that some effect patterns cannot be transformed.

For more information, refer to “Effect Pattern Transformations and Modifications” in the Appendix (separate document).

#### To change the aspect ratio of an effect pattern (Aspect)

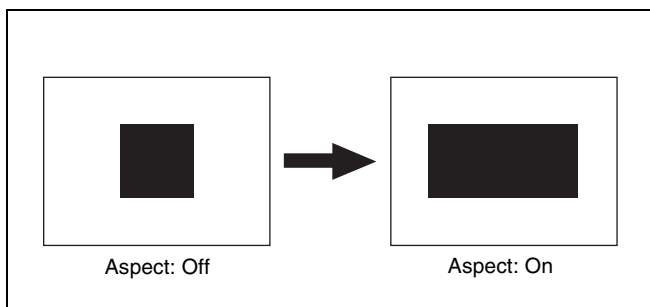

- 1 From the top menu, select Effect/Wipe >M/E Effect >Modify (Ptn 1-999).

The Modify (Ptn No.0001-0999) menu appears.

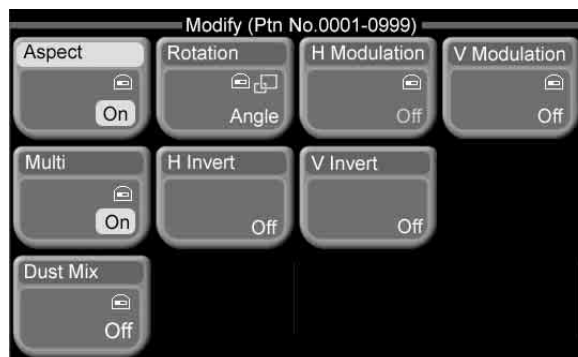

- 2 Press [Aspect], turning it on.
- 3 Set the aspect ratio parameter with knob 1.

Knob	Description	Setting values
1 (Aspect)	Aspect ratio of pattern	-100.00 to +100.00 <sup>a)</sup>

a) Minus values make the pattern taller, and plus values make the pattern longer.

#### To rotate an effect pattern (Rotation)

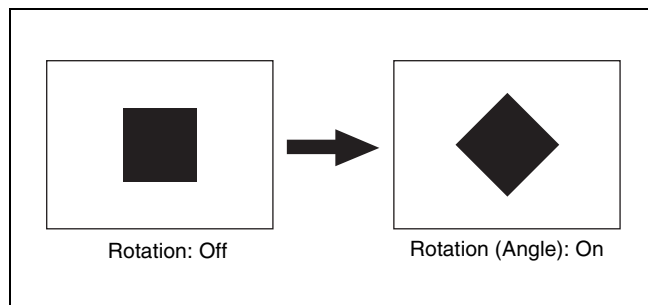

- 1 In the Effect/Wipe >M/E Effect >Modify (Ptn No. 0001-0999) menu (see previous section), press [Rotation].

A popup window appears.



**2** Set the following as required.

- Angle:** Slant the pattern at a specified angle.
- Speed:** Rotate the pattern at a specified speed.
- Magnitude:** Rotate the pattern to a specified angle during the transition.

**3** Set the following parameters according to the selection in step 2.

**When Angle was selected:**

Knob	Description	Setting values
1 (Angle)	Angle of pattern slant	-100.00 to +100.00 <sup>a)</sup>

a) -100.00 is one rotation in the counterclockwise direction, and +100.00 is one rotation in the clockwise direction. 0.00 is no rotation.

**When Speed was selected:**

Knob	Description	Setting values
1 (Speed)	Speed of pattern rotation	-100.00 to +100.00 <sup>a)</sup>

a) -100.00 is one rotation per second in the counterclockwise direction, and +100.00 is one rotation per second in the clockwise direction.

**When Magnitude was selected:**

Knob	Description	Setting values
1 (Angle)	Angle of pattern slant	-100.00 to +100.00 <sup>a)</sup>
2 (Magnitude)	Magnitude of rotation during transition	-200.00 to +200.00 <sup>b)</sup>

a) -100.00 is one rotation in the counterclockwise direction, and +100.00 is one rotation in the clockwise direction. 0.00 is no rotation.  
 b) -200.00 is two rotations in the counterclockwise direction, and +200.00 is two rotations in the clockwise direction. 0.00 is no rotation.

**To modulate effect patterns (H/V Modulation)**

This procedure is supported only for M/E effects.

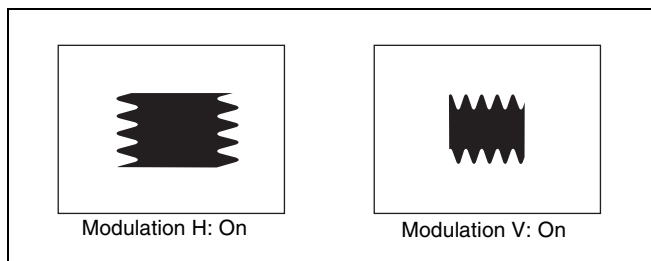

**1** In the Effect/Wipe >M/E Effect >Modify (Ptn No. 0001-0999) menu (*see page 103*), turn one or both of the following on.

- H Modulation:** Modulate horizontally.
- V Modulation:** Modulate vertically.

**2** Set the parameters with the knobs.

Knob	Description	Setting values
1 (Amplitude)	Amplitude of modulation wave	0.00 to 100.00
2 (Frequency)	Frequency of modulation wave	0.00 to 100.00
3 (Speed)	Speed of modulation	-100.00 to +100.00 <sup>a)</sup>
4 (Shape)	Shape of modulation wave	1 to 3 <sup>b)</sup>

a) In H Modulation, maximum speed is at -100.00 in the left direction and +100.00 in the right direction.  
 In V Modulation, maximum speed is at -100.00 in the downward direction and +100.00 in the upward direction.  
 b) 1: Sine wave, 2: Triangular wave, 3: Rectangular wave

**To arrange several examples of the same effect pattern (Multi)**

**1** In the Effect/Wipe >M/E Effect >Modify (Ptn No. 0001-0999) menu (*see page 103*), press [Multi], turning it on.

**2** Set the following parameters with the knobs.

**For an M/E effect:**

Knob	Description	Setting values
1 (H Multi)	Number of patterns arranged horizontally	1 to 63
2 (V Multi)	Number of patterns arranged vertically	1 to 63
3 (Shift)	Amount of horizontal shift of patterns in even numbered rows	-100.00 to +100.00 <sup>a)</sup>

a) Minus values shift to the left, and plus values shift to the right.

**For a PGM/PST wipe:**

Knob	Description	Setting values
1 (H Multi)	Number of patterns arranged horizontally	1 to 63
2 (V Multi)	Number of patterns arranged vertically	1 to 63

Knob	Description	Setting values
3 (Invert Type)	Replication layout	1 to 4 (see the following figure)



- 1: All patterns point in same direction
- 2: Even numbered rows move in horizontal direction
- 3: Even numbered columns and rows are inverted
- 4: Even numbered columns and rows are inverted, and even numbered rows move in horizontal direction

**3** For an M/E effect, do the following to invert the direction of every other pattern.

- To invert every other pattern in the horizontal direction, press [H Invert].
- To invert every other pattern in the vertical direction, press [V Invert].

### To mix in a diamond dust effect (Dust Mix)

This procedure is supported only for M/E effects.

- 1** In the Effect/Wipe >M/E Effect >Modify (Ptn No. 0001-0999) menu (see page 103), press [Dust Mix], turning it on.
- 2** Set the following parameters with the knobs.

Knob	Description	Setting values
1 (Mix Ratio)	Ratio of diamond dust mixed in	0.00 to 100.00
2 (H Size)	Horizontal size of particles	0.00 to 100.00
3 (V Size)	Vertical size of particles	0.00 to 100.00
4 (Flash Rate)	Flash rate of particles	0.00 to 100.00

## Cropping Effects

This operation can only be carried out on M/E effects. It is not supported for some patterns.

For more information, refer to “Effect Pattern Transformations and Modifications” in the Appendix (separate document).

### To turn the crop function on

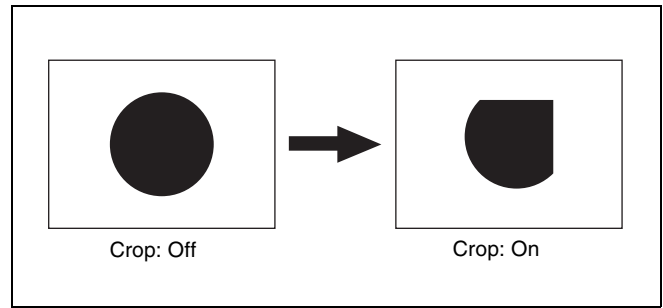

- 1** Press the [CROP] button in the Effect/Wipe control block, turning it on.  
Or, in the Effect/Wipe >M/E Effect >Crop menu, turn [Crop] on.

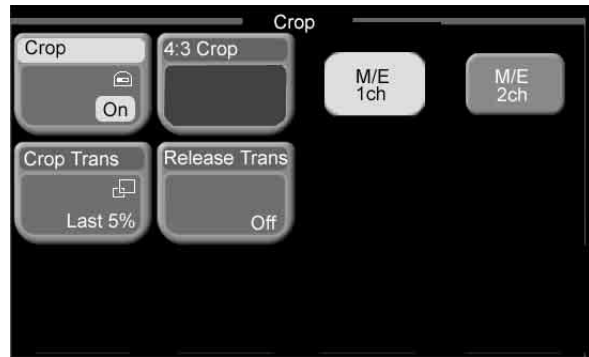

- 2** Select the operating channels. (See “Selecting Channels” (page 68).)
- 3** Set the following parameters with the knobs.

Knob	Description	Setting values
1 (Left)	Crop left side of image.	-100.00 to +100.00
2 (Right)	Crop right side of image.	-100.00 to +100.00
3 (Top)	Crop top side of image.	-100.00 to +100.00
4 (Bottom)	Crop bottom side of image.	-100.00 to +100.00
5 (All)	Crop all sides of image.	Left value shown

### To crop to 4:3 in 16:9 mode

In HD format 16:9 mode, you can crop the video to 4:3.

- 1** Press the [CROP] button in the Effect/Wipe control block, turning it on.  
Or, in the Effect/Wipe >M/E Effect >Crop menu, turn [Crop] on.
- 2** In the Crop menu, press [4:3 Crop].

## To set a relationship between transition progress and cropping

1 Carry out the procedure in the previous section “To turn the crop function on” (see page 105).

2 In the Crop menu, press [Crop Trans].

A popup window appears.



3 Select one of the following, as required.

**Cut:** Cut mode. The crop is unchanged during the transition, and is released when the transition completes.

**Last 5%:** The crop is unchanged until the transition is 95% complete, and is released during the remaining 5%.

**Linear:** The cropping is removed linearly through the whole course of the transition.

4 If you selected “Last 5%” in step 3, press [Release Trans] to set the timing of transition completion.

A popup window appears.



5 Select one of the following, as required.

**Last30%:** The transition completes at the end of 70% of the transition execution time. The transition has a dead zone from 70% to 95% of the transition time. The crop and the other effects are removed during the last 5% (enlarges).

**Last5%:** The transition completes at the end of 95% of the transition execution time. When the transition completes, the cropping is removed during the last 5% (enlarges).

**Off:** The transition completes at the end of the transition execution time. During the last 5% of the transition, the transition and cropping removal proceed together.

(See following diagram.)

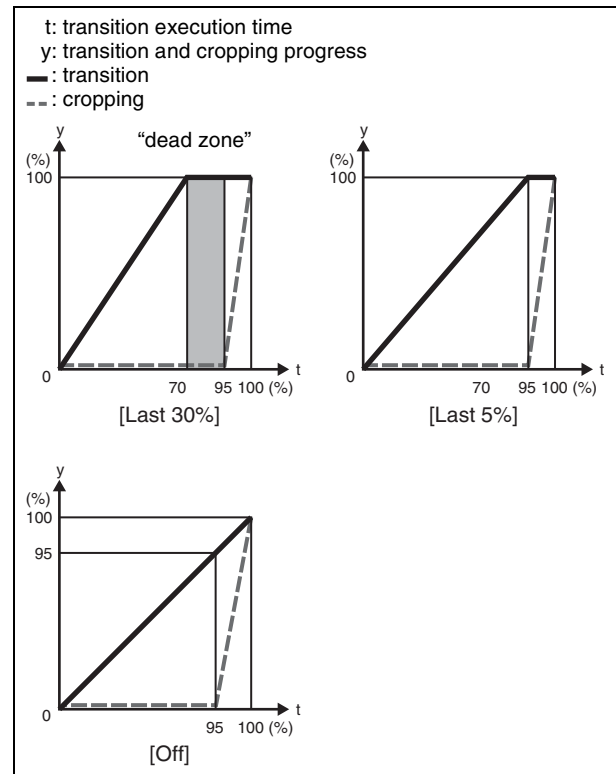

## Adding Beveled Edges to Video

This operation can only be carried out on M/E effects. It is not supported for some patterns.

For more information, refer to “Effect Pattern Transformations and Modifications” in the Appendix (separate document).

### Light mode and color mode

You can add beveled edges in light mode or color mode.  
**Light mode:** Beveled edges are produced by varying the brightness at the edges of the video.

**Color mode:** Beveled edges are produced by adding color at the edges of the video.

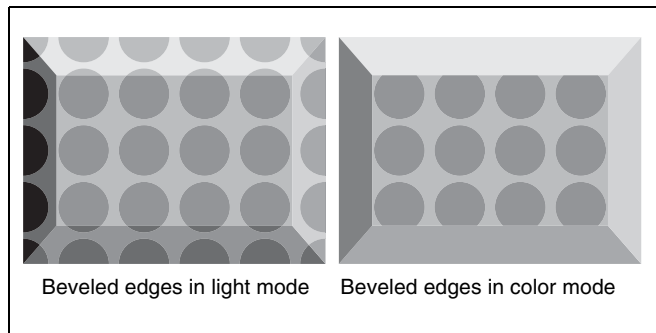

## To add beveled edges to video

### Note

Beveled edges are added to both channels of 2-channel effects. They cannot be added to individual channels.

- 1 Press the [BVLVD EDGE] button in the Effect/Wipe control block, turning it on.  
Or, in the Effect/Wipe >M/E Effect >Beveled Edge menu, turn [Beveled Edge] on.

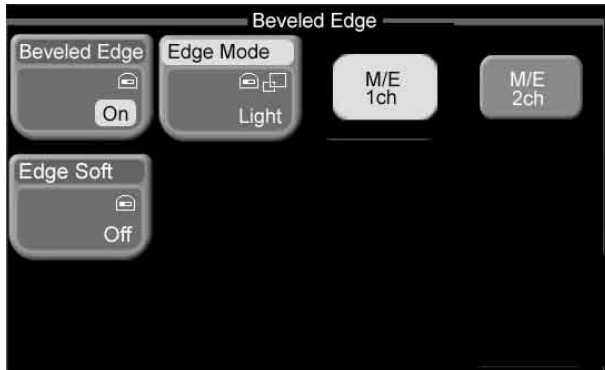

- 2 Set the following parameter with knob 1.

Knob	Description	Setting values
1 (Width)	Width of beveled edges	0.00 to 100.00 <sup>a)</sup>

a) 100 is 1/2 of the full-sized picture.

- 3 Press [Edge Mode], turning it on.

A popup window appears.



- 4 Press [Light] to select light mode, or [Color] to select color mode. (See the previous section “Light mode and color mode” )

- 5 Select the operating channels. (See “Selecting Channels” (page 68).)

- 6 Set the following parameters with the knobs.

### Light mode:

Knob	Description	Setting values
1 (Inten 1)	Luminance of edges on side close to light source	0.00 to 200.00 <sup>a)</sup>
2 (Inten 2)	Luminance of edges on side away from light source	0.00 to 200.00 <sup>a)</sup>
3 (Angle)	Direction of light source	-100.00 to +100.00 <sup>b)</sup>

a) 0.00 is no luminance component (edges are black). 100.00 is no addition. 200.00 is twice as bright.

b) 0.00 is light striking from the right side of the picture. -100.00 is one rotation in the counterclockwise direction, and +100.00 is one rotation in the clockwise direction.

### Example: Changing the angle value

Inten 1: 80  
Inten 2: 180

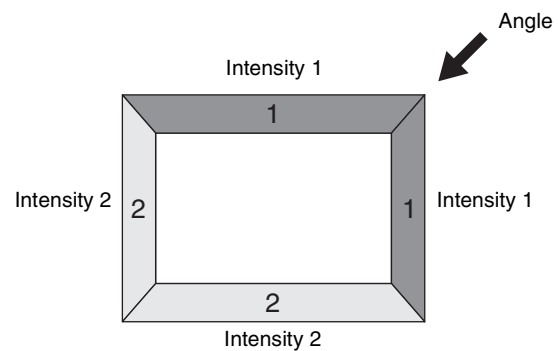

The edges corresponding to Inten 1 and Inten 2 change depending on the angle.

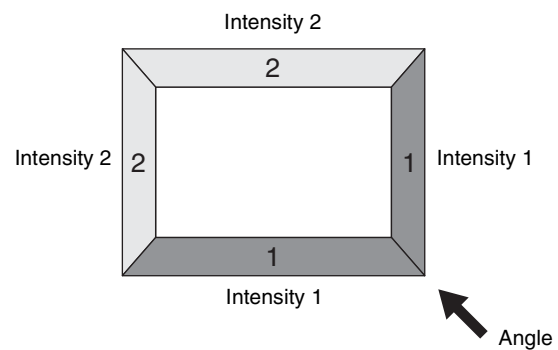

### Color mode:

#### Parameter group [1/2]

Knob	Description	Setting values
1 (Lum 1)	Luminance of edges on side close to light source	0.00 to 100.00
2 (Sat 1)	Saturation of edges on side close to light source	0.00 to 100.00

### Parameter group [1/2]

Knob	Description	Setting values
3 (Hue) <sup>a)</sup>	Hue of edges	359.99 to 0.00
4 (Angle) <sup>a)</sup>	Direction of light source	-100.00 to +100.00 <sup>b)</sup>

### Parameter group [2/2]

Knob	Description	Setting values
1 (Lum 2)	Luminance of edges on side away from light source	0.00 to 100.00
2 (Sat 2)	Saturation of edges on side away from light source	0.00 to 100.00
3 (Hue) <sup>a)</sup>	Hue of edges	359.99 to 0.00
4 (Angle) <sup>a)</sup>	Direction of light source	-100.00 to +100.00 <sup>b)</sup>

- a) Knobs 3 and 4 are shared by parameter groups 1/2 and 2/2.  
 b) 0.00 is light striking from the right side of the picture. -100.00 is one rotation in the counterclockwise direction, and +100.00 is one rotation in the clockwise direction.

## To soften beveled edges

- 1 In the Effect/Wipe >M/E Effect >Beveled Edge menu, turn [Edge Soft] on.
- 2 Select the operating channels. (See “Selecting Channels” (page 68).)
- 3 Set the following parameters with the knobs.

Knob	Description	Setting values
1 (Inner)	Softness of inner side of edges	0.00 to 100.00
2 (Boundary)	Softness of edge boundaries	0.00 to 100.00

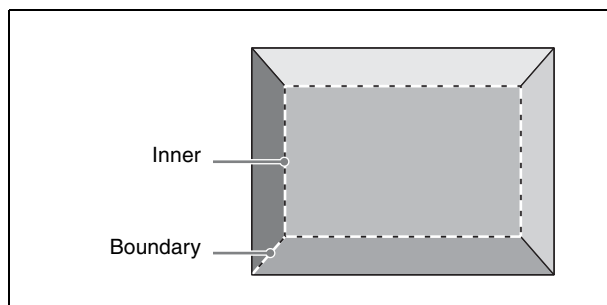

## Adding Lighting

This operation can only be carried out on M/E effects. It is not supported for some patterns.

For more information, refer to “Effect Pattern Transformations and Modifications” in the Appendix (separate document).

## Lighting types

There are three types of lighting. The type of lighting is fixed in advance for each effect number. It cannot be selected.

**Plane light:** Parallel light rays strike the picture from a specified direction. You can set the direction. The brightness of the light varies according to the angle.

**Preset light:** Light strikes the picture in a form which varies according to the effect pattern. Brightness is constant, regardless of the position of the picture.

**Preset + shade:** Shading is added to the Preset light described above.

## To add lighting

### Note

Lighting is added to both channels of 2-channel effects. It cannot be added to nor adjusted for individual channels.

- 1 Press the [LIGHT] button in the Effect/Wipe control block, turning it on. Or, in the Effect/Wipe >M/E Effect >Lighting menu, turn [Lighting] on.

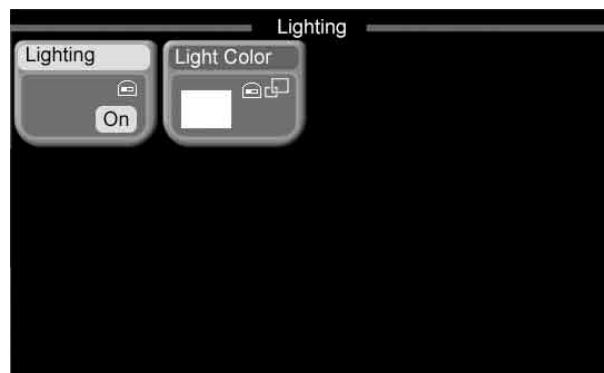

- 2 Set the following parameters with the knobs. Parameters vary depending on the type of lighting used by the selected effect.

### Plane light:

Knob	Description	Setting values
3 (Intensity)	Strength of light	0.00 to 100.00

### Preset light:

Knob	Description	Setting values
1 (Width)	Width of light	0.00 to 200.00 <sup>a)</sup>
2 (Soft)	Softness of light boundaries	0.00 to 200.00 <sup>a)</sup>

Knob	Description	Setting values
3 (Intensity)	Strength of light	0.00 to 100.00

**Preset + shade:**

Knob	Description	Setting values
1 (Width)	Width of light	0.00 to 200.00 <sup>a)</sup>
2 (Soft)	Softness of light boundaries	0.00 to 200.00 <sup>a)</sup>
3 (Intensity)	Strength of light	0.00 to 100.00
4 (Shade Ints)	Intensity of light shadow	0.00 to 100.00 <sup>b)</sup>
5 (Shade Gain)	Gain of shadow color	0.00 to 100.00 <sup>c)</sup>

- a) 100 is the value of the effect pattern width parameter when the effect pattern was applied.
- b) 0 is no lighting. 100 is strong lighting.
- c) 0 is black.

### To set the light color

- 1 In the Effect/Wipe >M/E Effect >Lighting menu, press [Light Color].  
A popup window appears.
- 2 Press a button with a color that is close to the color you want.
- 3 Set the following parameters with the knobs.

Knob	Description	Setting values
1 (Lum)	Luminance	0.00 to 100.00
2 (Sat)	Saturation	0.00 to 100.00
3 (Hue)	Hue	359.99 to 0.00

### Adding Afterimages (Trail)

This operation can only be carried out on M/E effects. It is not supported for some patterns.

*For more information, refer to “Effect Pattern Transformations and Modifications” in the Appendix (separate document).*

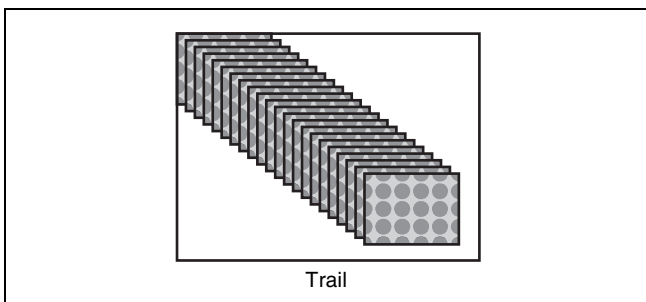

### To add afterimages

**Notes**

- Trails are added to both channels of 2-channel effects. They cannot be added to nor adjusted for individual channels.
- When Trail is enabled, Shadow (see page 110) is disabled.

- 1 Press the [TRAIL/SHDW] button in the Effect/Wipe control block, turning it on.  
Or, in the Effect/Wipe >M/E Effect >Trail/Shadow menu, turn [Trail/Shdw] on.

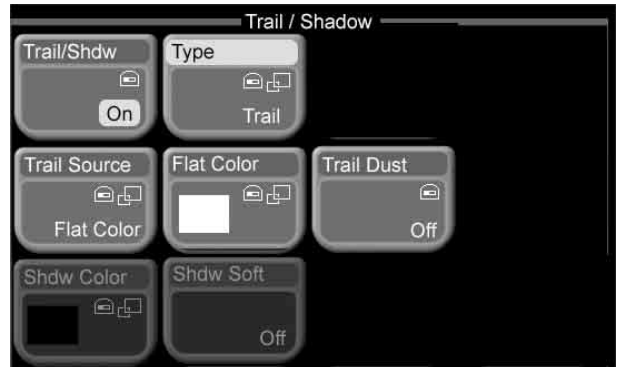

- 2 Press [Type].  
A popup window appears.
- 3 Select [Trail].



- 4 Set the following parameter with knob 1.

Knob	Description	Setting values
1 (Decay)	Degree to which the trail is left	0.00 to 100.00

### To select the image to use in afterimages

- 1 In the Effect/Wipe >M/E Effect >Trail/Shadow menu, press [Trail Source].  
A popup window appears.



**2** Select one of the following as the image to insert into afterimages.

**Freeze Video:** Freeze images from the input video.

**Flat Color:** Single-color matte.

**Hue Rotate:** Single-color mattes, with the hue changing for each frame.

**3** If you selected Flat Color or Hue Rotate in step **2**, adjust the following parameters.

**Flat Color:**

Knob	Description	Setting values
1 (Lum)	Luminance	0.00 to 100.00
2 (Sat)	Saturation	0.00 to 100.00
3 (Hue)	Hue	359.99 to 0.00

**Hue Rotate:**

Knob	Description	Setting values
1 (Lum)	Luminance	0.00 to 100.00
2 (Sat)	Saturation	0.00 to 100.00
3 (Hue Speed)	Speed at which the hue changes	-100.00 to +100.00

### To set afterimage colors from a menu

When the image in afterimages is Flat Color, you can press [Flat Color] and set the color from the popup window which appears.

See page 61 for more information about how to set the color.

### To transform afterimages into stardust

**1** In the Effect/Wipe > M/E Effect > Trail/Shadow menu, turn [Trail Dust] on.

**2** Set the following parameters with the knobs.

Knob	Description	Setting values
1 (Trail Dust)	Amount of the afterimage disappearing as stardust	0.00 to 100.00 <sup>a)</sup>
2 (Dust Soft)	Timing with which stardust disappears	0.00 to 100.00 <sup>b)</sup>
3 (Dust Size)	Size of stardust	0.00 to 100.00

a) 0.00 is no afterimages. 100.00 is no transformation of afterimages into stardust.

b) Higher values make the stardust disappear more slowly.

## Adding Shadows Around Effects

This operation can only be carried out on M/E effects. It is not supported for some patterns.

For more information, refer to “Effect Pattern Transformations and Modifications” in the Appendix (separate document).

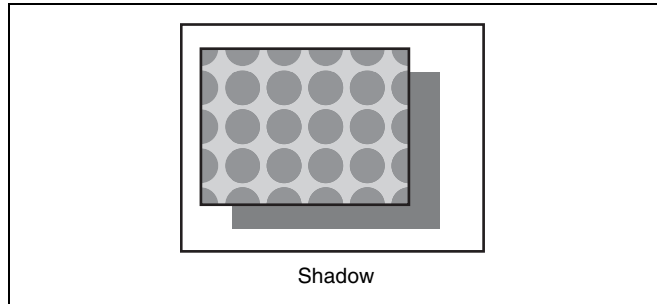

### To add shadows

#### Notes

- Shadows are added to both channels of 2-channel effects. They cannot be added to nor adjusted for individual channels.
- When Shadow is enabled, Trail (see page 109) is disabled.

**1** Carry out steps **1** and **2** of “To add afterimages” (page 109).

**2** Select [Shadow].

**3** Set the following parameters with the knobs.

Knob	Description	Setting values
1 (H Position)	Position in horizontal direction	-200.00 to +200.00 <sup>a)</sup>
2 (V Position)	Position in vertical direction	-200.00 to 0.00 <sup>b)</sup>
3 (Density)	Density of shadow	0.00 to 100.00

- a) -200.00 moves left by the horizontal width of the screen, and +200.00 moves right by the horizontal width of the screen.  
 b) -200.00 moves down by the vertical size of the screen. 0.00 is approximately the same position as the image.

## To set the shadow color

- In the Effect/Wipe >M/E Effect >Trail/Shadow menu, press [Shdw Color].  
A popup window appears.
- Press a button for a color that is close to the color you want.
- Set the following parameters with the knobs.

Knob	Description	Setting values
1 (Lum)	Luminance	0.00 to 100.00
2 (Sat)	Saturation	0.00 to 100.00
3 (Hue)	Hue	359.99 to 0.00

## To soften the edges of the shadow

In the Effect/Wipe >M/E Effect >Trail/Shadow menu, turn [Shdw Soft] on.

## Selecting the interpolation methods

When the signal format is 576i or 480i, it is possible to specify the interpolation method for input video signals and input key signals.

- From the top menu, select Effect/Wipe >M/E Effect >Interpolation.

The Interpolation menu appears.

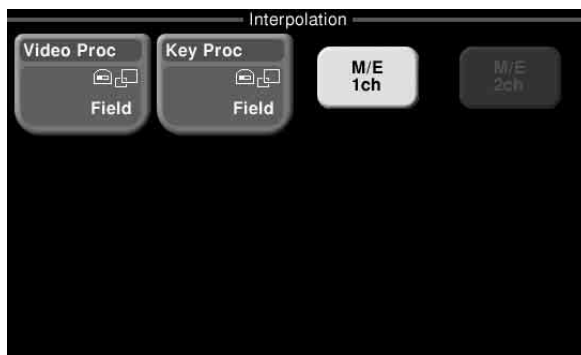

- Press [M/E 1ch] or [M/E 2ch] to select a channel.
- To select the interpolation method for the video signal, press [Video Proc].  
A popup window appears.
- Select one of the following.

**Adaptive Y/C:** Detect changes in the luminance and chrominance components of the video signal separately, and switch automatically between fields and frames.

**Adaptive Y:** Detect changes in the luminance component of the video signal, and switch automatically between fields and frames.

**Field:** Do interpolation in field units. This gives natural movement, suitable for moving video.

**Frame:** Do interpolation in frame units. This gives higher image precision, suitable for still pictures.

- If you selected [Adaptive Y/C] or [Adaptive Y] in step 4, set the following parameter.

Knob	Description	Setting values
1 (Mode)	Degree of motion detection	1 to 4 <sup>a)</sup>

- a) 1: Frame-based motion detection. 4: Field-based motion detection.

- To select the interpolation method for the key signal, press [Key Proc].

A popup window appears.

- Select one of the following.

**Adaptive:** Detect changes in the luminance component of the key signal separately, and switch automatically between fields and frames.

**Field:** Do interpolation in field units. This gives natural movement, suitable for moving video.

**Frame:** Do interpolation in frame units. This gives higher image precision, suitable for still pictures.

- If you selected [Adaptive] in step 7, set the following parameter.

Knob	Description	Setting values
1 (Mode)	Degree of motion detection	1 to 4

- a) 1: Frame-based motion detection. 4: Field-based motion detection.

## Composing a Video Border Color From Two Colors

You can compose the color of video borders from any two colors.

This operation can only be carried out on M/E effects.

About the basic border settings, see “Adding Borders to Video” (page 74).

- 1 From the top menu, select Effect/Wipe >M/E Effect >Border Color.

The Border Color menu appears.

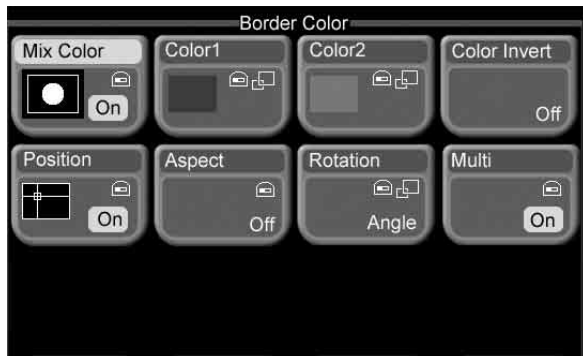

- 2 Set the pattern used to mix the 2 colors, and specify color 1 and color 2.

See “To compose a pattern of two colors (color mix)” (page 96) and “To transform color mix patterns” (page 97) for information on how to set the parameters.

Note that “Mix Color” is effective only when both of the following conditions are met.

- In the Effect/Wipe >M/E Effect >Main menu, [Border Fill] is set to “Matte”.
- One of the effect pattern numbers 0001 to 0999 is selected.

## Using Pattern Specific Transformations

In addition to the transformation described in “Transforming Effect Patterns” (see page 103), there are also specific transformations which are permitted by some effect patterns.

An example of one such transformation is provided below. For more information, refer to “Effect Pattern Transition Parameter List” in the Appendix (separate document).

## Example of a pattern specific transformation (Matrix)

- 1 Select one of the effect pattern numbers listed below.  
0200 to 0203, 0206 to 0213, 0224 to 0247, 0250 to 0257, 0260 to 0269.
- 2 Set the following parameters with the knobs.

Knob	Description	Setting values
1 (H Tile No)	Number of tiles in horizontal direction	2 to 36
2 (V Tile No)	Number of tiles in vertical direction	2 to 18

## Using User Programmable DME Effects

You can import user programmable DME patterns<sup>1)</sup> created by keyframe operations on the MVS-8000 Multi Format Switcher or the DVS-9000 Production Switcher, and use them as effects on this system.

1) The versions 3.00 to 5.10 of the MVE-8000/8000A/9000 DME processor and those of the BKDS-9470 DME Board Set are supported.

The procedure for using user programmable DME effects is as follows.

- 1 Create user programmable DME patterns on the MVS-8000 or DVS-9000.

### Points to note about creating user programmable DME patterns

Note the following points when creating user programmable DME patterns.

- Create effects with an aspect ratio that is usable on this system.
- Functions used to create effects should be within the range that is usable by the two-channel system of the MVE-8000A dedicated interface.
- If you need DME wipe patterns with the same picture quality as when the keyframes were created, create the keyframes on the MVE-8000A.

Refer to the user’s guides of the MVS-8000 and DVS-9000 for more information about how to create user programmable DME patterns.

- 2 Save the new user programmable DME patterns on a “Memory Stick”.

### Points to note about saving user programmable DME patterns

- Always initialize the “Memory Stick” before saving DME patterns.

- After the import, patterns are identified by the names of the registers where they were saved.  
Assign names as required to the registers (up to eight characters).
- The registers which may be used for effects are as follows.

Execution mode	Register number	Effect pattern number
One-channel mode	101 to 199 <sup>a)</sup>	1901 to 1999 <sup>c)</sup>
Two-channel mode	201 to 299 <sup>b)</sup>	2901 to 2999 <sup>c)</sup>

- a) Shared registers for one-channel patterns  
 b) Shared registers for two-channel patterns  
 c) See “About effect pattern numbers” (page 67).

- The import menu for user programmable DME effects does not support register editing functions. Save only the effects that you need.

Refer to the user’s guides of the MVS-8000 and DVS-9000 for more information about how to save user programmable DME patterns.

### 3 Import the user programmable DME patterns.

See “Importing DME Effects” (page 189) for information about the import procedure.

### 4 Select an effect.

As explained in “Points to note about saving user programmable DME patterns” in step 2, effect pattern numbers correspond to the numbers of the registers where they were saved on the MVS-8000 or DVS-9000.

See “Selecting Effects” (page 63) for information about the selecting effects.

### 5 Add modifiers as required.

For the modifiers of position effects, see “Changing the Position and Size of Effect Patterns” (page 70), “Modifying Video Borders” (page 73) and “Advanced Effect Operations” (page 103).

#### Notes

- If modifiers are added on the MVS-8000 or DVS-9000 when creating keyframes, and the same modifiers are added on this system, the modifiers added on this system take priority.
- Depending on how imported keyframes were created, some modifiers may not appear even when they are turned on.

## Making the Pattern Limit Setting

You can set the range of the transition during execution of an effect (wipe).

When you execute a transition with the pattern limit function on, the results will be as follows depending on the execution range setting.

- When the limit value is set to 50%, the effect at the end of the transition is the same as when the fader lever is at the center position in the normal case (with the pattern limit function disabled); the wipe pattern does not complete.
- When the limit value is set to 0%, the wipe effect is completely disabled, and carrying out the transition produces no change in the image.
- When the limit value is set to the maximum 100%, the image changes in exactly the same way as when the pattern limit function is off, but when the transition is completed, the cross-point selections do not interchange between the background A and B buses.

#### Notes

A pattern limit only applies when an effect (wipe) is selected as the transition type. It cannot be applied to a mix, preset color mix, or clip transition.

A pattern limit cannot be applied when the pattern number 0901 or 0902 is selected.

### To set pattern limits

The following procedure shows the case of an M/E bank setting, but the same basic procedure also applies to a PGM/PST bank setting.

- 1 From the top menu, select Effect/Wipe >M/E Effect >Pattern Limit.

The Pattern Limit menu appears.

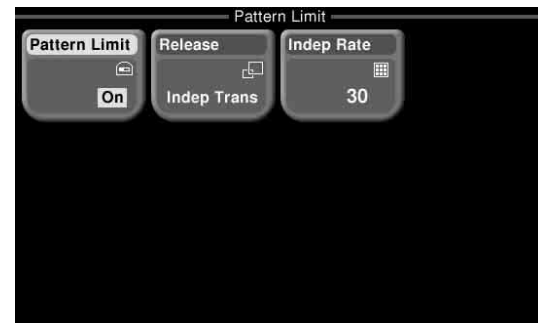

- 2 Press [Pattern Limit], turning it on.
- 3 Set the following parameter with the knob.

Knob	Description	Setting values
1 (Ptn Limit)	Transition execution range	0.00 to 100.00

#### 4 Carry out the transition.

The transition progresses as far as the set pattern limit.

#### 5 Carry out the transition once again.

The status before the previous transition is restored.

### To release the pattern limit

- To release the pattern limit after completion of step 5 in the previous procedure, in the Pattern Limit menu press [Pattern Limit], turning it off.
- If after carrying out step 4 in the previous procedure, the pattern limit has been reached, proceed as follows.

#### 1 In the Effect/Wipe >M/E Effect >Pattern Limit menu press [Release].

A popup window appears.

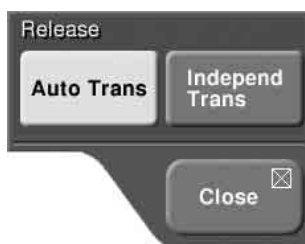

#### 2 Select the transition rate when the pattern limit is released.

**Auto Trans:** Use the transition rate set in the M/E transition control block or PGM/PST transition control block.

**Independ Trans:** Use the transition rate set for pattern limit release. (See next item.)

#### 3 Press [Pattern Limit], turning it off.

#### 4 Carry out the transition.

This releases the pattern limit.

Depending on the way in which the transition was executed, the action will be as follows.

- When you press the [CUT] button, the pattern limit is immediately released, and the image switches instantaneously.
- When you press the [AUTO TRANS] button, until the state of the next transition, the transition is carried out over the duration given by the transition rate.
- When you move the fader lever, the transition is carried out from the pattern limit state to the state before the pattern limit transition was carried out. Moving the fader lever even a little synchronizes the fader lever position with the transition state, and you can move the fader lever either in the forward direction or in the reverse direction.

### To set the transition rate when the pattern limit is released

#### 1 In the Effect/Wipe >M/E Effect >Pattern Limit menu, press [Indep Rate].

The numeric keypad window appears.

#### 2 Enter the desired number of frames in the range 0 to 999, and press [Enter].

This confirms the input, and the transition rate appears on the button.

## Saving, Recalling, and Deleting Effect Snapshots

You can save snapshots of the current effect pattern numbers, transformation parameters, and so on, and recall them for later use. These snapshots are called “effect snapshots”.

There are ten effect snapshot registers (1 to 10) on each of the M/E and P/P regions. (A region means a functional unit block of the system.)

### Saving effect snapshots

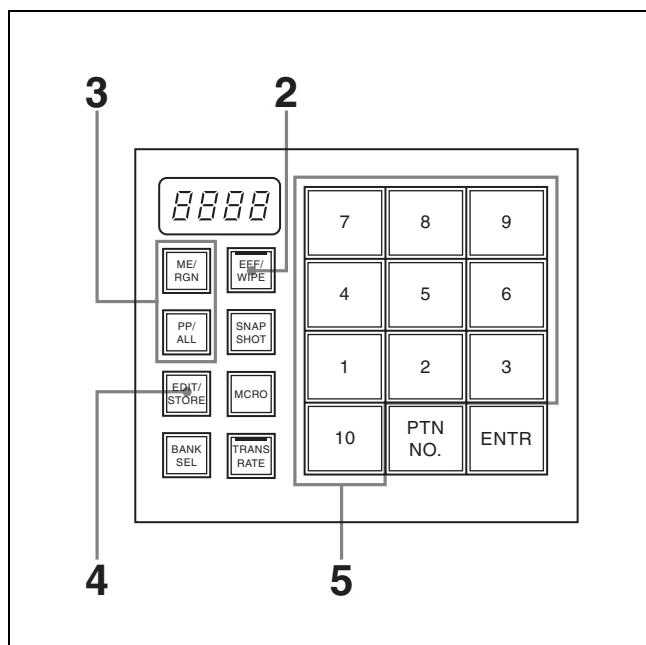

#### 1 Make the effect settings that you want to save.

#### 2 In the Flexi Pad control block, press the [EFF/WIPE] button, lighting it.

The Flexi Pad control block enters effect snapshot mode, and the memory recall buttons take on the configuration shown above.

- 3 Press and light the region selection button for the region that you want to save.
  - To save M/E effect settings, press the [ME/RGN] button.
  - To save PGM/PST effect settings, press the [PP/ALL] button (1.5M/E panel only).
- 4 Press the [EDIT/STORE] button, lighting it.  
The system is now ready to save an effect snapshot.
- 5 Press the memory recall button for the register in which you want to save the effect snapshot.

**Note**

Pressing a button which is lit in orange or yellow will overwrite the current contents of the register.

When the save is complete, the button that you pressed lights in yellow and the number on the button changes from a register number to an effect pattern figure. The pattern number appears in the numeric display.

**Recalling effect snapshots**

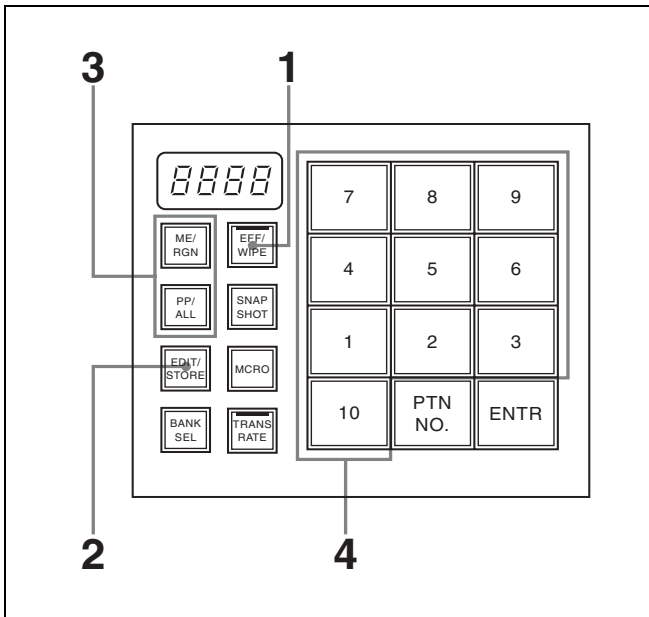

- 1 In the Flexi Pad control block, press the [EFF/WIPE] button, lighting it.
- 2 If the [EDIT/STORE] button is lit, press it to turn it off.
- 3 Press to light the region selection button (ME/RGN or PP/ALL) for the region of the snapshot that you want to recall.

The memory recall buttons show figures of the saved effect patterns. Buttons where snapshots are already saved are lit in orange.

- 4 Press the memory recall button for the effect snapshot that you want.

When the recall finishes, the pressed button lights in yellow and the numeric display shows the pattern number of the corresponding pattern.

**Deleting effect snapshots**

With the [EDIT/STORE] button lit, hold the [EFF/WIPE] button down and press the memory recall button for the effect snapshot that you want to delete. The button you pressed is turned off, and the effect snapshot is deleted.

**Editing Effect Snapshot Registers**

You can edit snapshot registers in the following ways.

- Rename:** Rename the register.
- Lock:** Disable editing of the register (prevent overwriting and deletion of data in the register, and prevent renaming of the register).
- Delete:** Delete the data in the register.

**Renaming effect snapshot registers**

- 1 From the top menu, select Register >Eff/Wipe Snapshot >Edit.  
The Edit menu appears.
- 2 If you are using the 1.5 M/E panel, select the region in the status area. You can select several regions.

**Note**

Regions without register data cannot be selected.

- 3 Do one of the following to select the register.
  - Press directly on the list appearing in the status area.
  - Use the arrow buttons to scroll the reverse video cursor.
  - Turn the knob.

Knob	Description	Setting values
1 (Reg No)	Register number	1 to 10

The selected register appears in reverse video.

- 4 Press [Rename].

The keyboard window appears.

See “Keyboard window” (page 40) in Chapter 3 for more information about keyboard window operations.

**Notes**

- If you pressed [Select All], turning it on, or if you selected several registers, the register with the lowest number in the selected range is the target of the operation.
- [Rename] is disabled in the following cases.
  - When the selected register is locked (*see the next section*)
  - When the selected register is empty

- 5 Enter a name of up to eight characters, and then press [Enter].

The specified name appears in the list.

**Note**

The following names cannot be used:  
 CON, PRN, AUX, CLOCK\$, NUL, COM0, COM1, COM2, COM3, COM4, COM5, COM6, COM7, COM8, COM9  
 LPT0, LPT1, LPT2, LPT3, LPT4, LPT5, LPT6, LPT7, LPT8, LPT9

## Disabling editing of snapshot registers (locking the registers)

In the Edit menu, proceed as follows.

- 1 If you are using the 1.5 M/E panel, select the region in the status area. You can select several regions.

**Note**

Regions without register data cannot be selected.

- 2 Do one of the following to select the register.
  - Press directly on the list appearing in the status area.
  - Use the arrow buttons to scroll the reverse video cursor.
  - Turn the knobs.

Knob	Description	Setting values
1 (Reg No)	Register number	1 to 10
2 (Number)	Number of registers	1 to 10

- To select all registers, press [Select All], turning it on.

The selected register appears in reverse video.

- 3 Press [Lock], turning it on.

Register lock processing starts, and a progress window opens.

The window closes automatically if the processing is successful.

**To unlock the register**

Select the register to unlock, and then press [Lock], turning it off.

## Deleting the data in effect snapshot registers

In the Edit menu, proceed as follows.

- 1 If you are using the 1.5 M/E panel, select the region in the status area. You can select several regions.

**Note**

Regions without register data cannot be selected.

- 2 Do one of the following to select the register.
  - Press directly on the list appearing in the status area.
  - Use the arrow buttons to scroll the reverse video cursor.
  - Turn the knobs.

Knob	Description	Setting values
1 (Reg No)	Register number	1 to 10
2 (Number)	Number of registers	1 to 10

- To select all registers, press [Select All], turning it on.

The selected register appears in reverse video.

- 3 Press [Delete].  
A message appears asking you to confirm the deletion.

- 4 Press [Yes] to execute the deletion, or [No] to cancel it.  
If you pressed [Yes], the deletion is executed.  
If you pressed [No], you return to the state before step 3.

**Note**

Data in locked registers cannot be deleted.

# Advanced Key Operations

This section explains procedures for setting M/E key 1. The same procedures can be used for the other keys as well (M/E key 2, and downstream keys 1 and 2).

## Processing Key Signals

### To turn key clean mode on

#### Clean mode

In a luminance key or linear key, you can enable the clean mode. When the clean mode is on, the key source does not affect the key fill, which is added unchanged to the background. This improves the keyed image quality, but means that the part of the key fill signal which is not to be inserted must be completely black, or it will color the background.

This mode is effective when using character generators, which generate paired key source and key fill signals. Note that in the following situations, the clean mode goes off, and cannot be turned on.

- When the key type is a pattern key or chroma key
- When key inversion (Key Invert) is on
- When the Key Position function is on
- When fine key is on
- When the key fill is a matte
- When the key edge is anything other than normal
- When the key edge is normal, and soft edges are on

### To turn clean mode on

- 1 From the top menu, select Key >M/E Key1 >Key Source.

The Key Source menu appears.

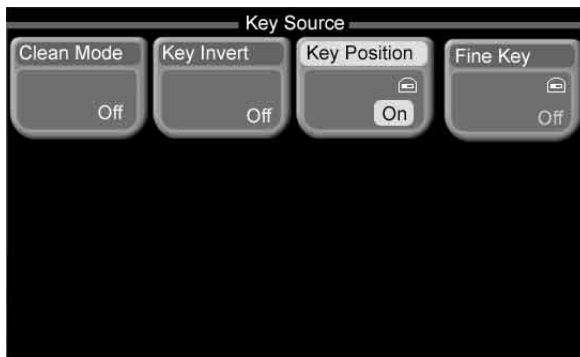

- 2 Press [Clean Mode], turning it on.

### To invert key signals

You can invert the black/white of key signals. This allows you to use a key source as black characters against a white background and white characters against a black background.

To turn the key inversion function on, in the Key >M/E Key1 >Key Source menu, press [Key Invert], turning it on.

### To adjust the key position

For luminance keys, linear keys, and chroma keys, you can move the edges of the key signal horizontally.

- 1 In the Key >M/E Key1 >Key Source menu, press [Key Position], turning it on.
- 2 Set the following parameters with the knobs.

Knob	Description	Setting values
1 (Left Pos)	Left edge position	-4.00 to +4.00
2 (Right Pos)	Right edge position	-4.00 to +4.00
3 (H Phase)	Horizontal direction position	Left Pos value shown

### To turn the fine key function on

When the fine key function is on, you can make fine adjustments to the left, right, top, and bottom edge positions of the key signal.

#### Note

When fine key is on, the width of borders, drop borders, drop shadows, and outlines is limited to a maximum of 4.

- 1 In the Key >M/E Key1 >Key Source menu, press [Fine Key], turning it on.
- 2 Make fine adjustments to key edge positions by setting the following parameters with the knobs.

#### Parameter group [1/2]

Knob	Description	Setting values
1 (Left Pos)	Left edge position	-2.00 to +2.00
2 (Right Pos)	Right edge position	-2.00 to +2.00
3 (Top Pos)	Top edge position	-2.00 to +2.00
4 (Bottom Pos)	Bottom edge position	-2.00 to +2.00

#### Parameter group [2/2]

Knob	Description	Setting values
1 (H Phase)	Horizontal position	Left Pos value shown
2 (V Phase)	Vertical position	Top Pos value shown

## Adjusting Key Borders

See “Adding Borders to Keys” (page 90) for more information about how to make basic key border settings.

### Applying 2-color borders

- 1 From the top menu, select Key >M/E Key1 >Edge.

The Edge menu appears.

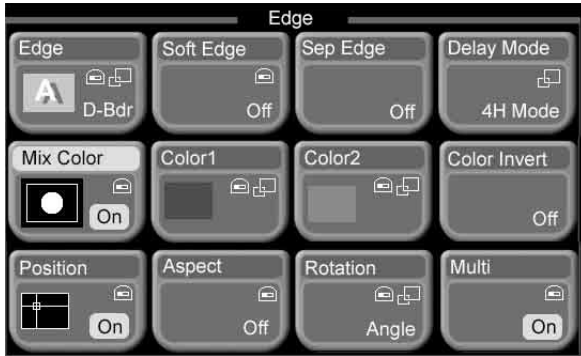

- 2 Press [Mix Color], turning it on.
- 3 Set the pattern used to mix the 2 colors, and specify color 1 and color 2.

See “To compose a pattern of two colors (color mix)” (page 96) and “To transform color mix patterns” (page 97) for information on how to set the parameters. Note that the parameters H Modulation and V Modulation are not available for color mix patterns.

### To set separate border widths (Separate Edge function)

When you add borders or outlines to luminance keys, linear keys, or chroma keys, you can set the widths of the four borders separately.

In the Key >M/E Key1 >Edge menu, press [Sep Edge], turning it on.

The width of the four borders are now separately adjustable.

### Setting maximum border widths

When you add borders, drop borders, drop shadows, or outlines to key edges, proceed as follows to set the maximum width.

- 1 In the Key >M/E Key1 >Edge menu, press [Delay Mode], turning it on.

A popup window appears.

- 2 Press one of the following.

**4H Mode:** Set the maximum width to 4 (4 lines). Key fill and key source drop down by 4 lines.

**8H Mode:** Set the maximum width to 8 (8 lines). Key fill and key source drop down by 8 lines.

## Adjusting Chroma Keys

Proceed as follows to make fine adjustments to the chroma key image obtained with auto chroma key (see page 88).

### To select the chroma key composition method

- 1 From the top menu, select Key >M/E Key1 >Chroma Key.

The Chroma Key menu appears.



- 2 Press [Mix Mode].

A popup window appears.



- 3 Select one of the following.

**Normal Mix:** The background is cut out with the key signal, and then combined with the foreground, which has also been cut out with the key signal.

**Additive Mix:** The background, which has been cut out with the key signal, is combined with the unshaped foreground. This is effective for a natural looking composite when the scene includes glass or other translucent objects.

## To turn the plane function on

In an additive mix, the foreground is not shaped by the key signal, and variations in the (blue) background appear in the composite image. To prevent this, it is possible to set a particular luminance level for the background, and forcibly cut any parts below this level. This is called the plane function.

The plane function is enabled when additive mix is selected.

- 1 In the Key >M/E Key1 >Chroma Key menu, press [Plane], turning it on.
- 2 Set the following parameter with knob 1.

Knob	Description	Setting values
1 (Lum)	Luminance level	0.00 to 100.00

## To adjust chroma keys manually

Methods of adjusting the composite obtained from chroma keying include automatic adjustment with the auto chroma key function, and manual adjustment carrying out the necessary processing separately. The optimum results will be obtained by first carrying out adjustments with the auto chroma key function, then making fine adjustments as required.

The following manual adjustments are possible.

- Key active
- Color cancel
- Window
- Y balance
- Chroma key shadow
- Video signal adjustment

## To make adjustments with key active

When the key active function is on, the composite video is output and you can adjust the composition method manually while viewing the monitor.

When the key active function is off, only the foreground is output. You should turn key active off when making manual adjustments with color cancel (*see the next section*).

- 1 In the Key >M/E Key1 >Chroma Key menu, turn [Key Active] on.
- 2 Set the following parameters with the knobs.

Knob	Description	Setting values
1 (Clip)	Chroma key reference level	0.00 to 100.00
2 (Gain)	Key gain	-100.00 to +100.00
3 (Hue)	Hue	359.99 to 0.00
4 (Density)	Key density	0.00 to 100.00
5 (Filter)	Filter coefficient	1 to 9 <sup>a)</sup>

a) Set to 1 for through processing, with no filter applied. The filter becomes stronger as larger numbers are specified.

## To make adjustments with color cancel

If the foreground image includes shades of the background color, turn this function on to remove the color from the foreground image.

- 1 In the Key >M/E Key1 >Chroma Key menu, turn [Key Active] off, and turn [Color Cancel] on.
- 2 Set the following parameters with the knobs.

Knob	Description	Setting values
1 (Lum)	Luminance	0.00 to 100.00
2 (Sat)	Saturation	0.00 to 100.00
3 (Hue)	Hue	359.99 to 0.00
4 (Filter)	Filter coefficient	1 to 9 <sup>a)</sup>

a) Set to 1 for through processing, with no filter applied. The filter becomes stronger as larger numbers are specified.

- 3 Turn [Key Active] on.

The video composed with chroma key reappears on the monitor.

## Adjusting the key signal for color cancel

When color cancel is on, you can adjust the key signal for color cancel.

- 1 In the Key >M/E Key1 >Chroma Key menu, press [Cancel Key], turning it on.  
The color cancel function is turned on.
- 2 Set the following parameters with the knobs.

Knob	Description	Setting values
1 (Clip)	Reference level of color cancel key	0.00 to 100.00
2 (Gain)	Key gain	-100.00 to +100.00

- 3 Make the following settings as required.

## Adjusting the color cancel key window (range of matching colors)

- 1 In the Key >M/E Key1 >Chroma Key menu, press [CC Window], turning it on.
- 2 Set the following parameters with the knobs.

Knob	Description	Setting values
1 (Crop)	Crop value <sup>a)</sup>	100.00 to 0.00
2 (Angle)	Angle value <sup>a)</sup>	180.00 to 0.00

a) See the figure in “To adjust the window”.

## Setting the color cancel key edge positions

- 1 In the Key >M/E Key1 >Chroma Key menu, press [CC Key Pos], turning it on.
- 2 Set the following parameters with the knobs.

Knob	Description	Setting values
1 (Left Pos)	Move the left edge of the color cancel key.	-3.00 to +3.00
2 (Right Pos)	Move the right edge of the color cancel key.	-3.00 to +3.00
3 (H Phase)	Horizontal position of the color cancel key.	Left Pos value shown

## Adjusting the ratio of Y balance added to a color cancel key

For the Y balance function, see “To adjust the Y balance” (page 120).

By using the Y balance function on a color cancel key, colors of the same hue as the background (typically blue) can be output in the foreground without being cancelled.

- 1 In the Key >M/E Key1 >Chroma Key menu, press [CC Y Balance], turning it on.
- 2 Set the following parameter with the knob.

Knob	Description	Setting values
1 (Mixture)	Y balance key ratio	0.00 to 100.00

## To adjust the window

Chroma keying generates a key signal based on a particular color (reference color) in the foreground (typically a plain blue background). The “window” refers to the range of colors which are regarded as matching this specified reference color to create the key signal. As seen on a vectorscope, the range for this matching corresponds to a truncated sector (see the following figure). This range is specified by two parameters: the

“Angle” parameter, which determines the range of the hue parameter, and the “Crop” parameter, which determines the degree of truncation.

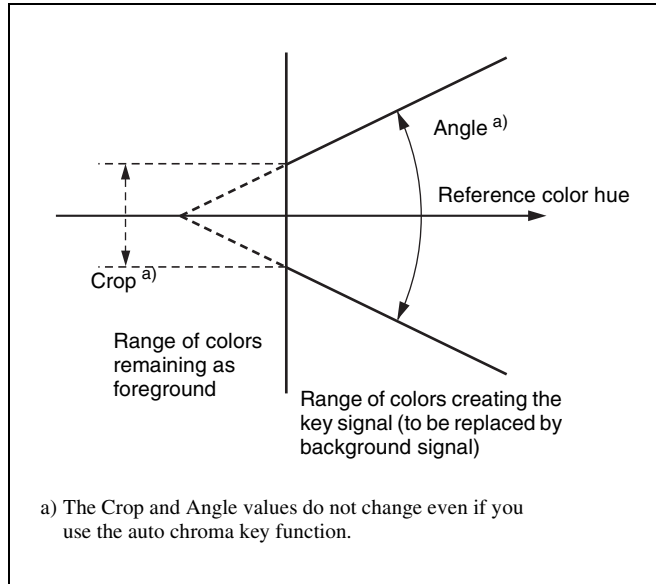

To adjust the window, the Clip, Gain, Hue must be adjusted to appropriate values. Set these to appropriate values first, and then proceed as follows.

- 1 In the Key >M/E Key1 >Chroma Key menu, press [Window], turning it on.
- 2 Set the following parameters with the knobs.

Knob	Description	Setting values
1 (Crop)	Crop value <sup>a)</sup>	100.00 to 0.00
2 (Angle)	Angle value <sup>a)</sup>	180.00 to 0.00

a) See above figure.

## To adjust the Y balance

In normal chroma keying, the key signal is based on the chrominance component only, and all elements of the foreground with the same hue are replaced by the background. Using the Y balance function, you can specify a luminance level range within which the key is active, and replace the specified part by the background. You can use the Y balance function independently on the key signal for the composition and the key signal for the color cancel function. When applied to the key signal for the composition, this produces the foreground with the color cancel effect applied. This can therefore be used to provide an impression of smoke, for example.

- 1 In the Key >M/E Key1 >Chroma Key menu, press [Y Balance], turning it on.
- 2 Set the following parameters with the knobs.

Knob	Description	Setting values
1 (Clip)	Reference level of color cancel key	0.00 to 100.00
2 (Gain)	Key gain	-100.00 to +100.00
3 (Lum)	Luminance	0.00 to 100.00

## To adjust chroma key shadows

This function provides a more realistic treatment when the shadow of an object in the field of view falls on the blue background. Since parts of the blue background darker than a specified intensity are treated as shadows, there is no effect on cutting out of the foreground.

- 1 In the Key >M/E Key1 >Chroma Key menu, press [Shadow], turning it on.
- 2 Set the following parameters with the knobs.

Knob	Description	Setting values
1 (Lum)	Reference luminance of shadow	0.00 to 100.00
2 (Gain)	Gain of shadow key	-100.00 to +100.00
3 (Density)	Density of shadow	0.00 to 100.00
4 (Soft)	Softness of shadow	0.00 to 100.00

### Note

When chroma key shadowing is on, key edges are normal with soft edges off.

## To adjust video signals

You can vary the gain and hue of chroma key foreground video. Gain can be adjusted for the overall video signal, or individually for Y and C.

- 1 In the Key >M/E Key1 >Chroma Key menu, press [Frgd V Proc], turning it on.
- 2 Adjust the following parameters with the knobs.

Knob	Description	Setting values
1 (Video Gain)	Overall gain of video signal	-100.00 to +100.00
2 (Y Gain)	Gain of Y signal	-100.00 to +100.00
3 (C Gain)	Gain of C signal	-100.00 to +100.00
4 (Hue Offset)	Amount of hue offset	-180.00 to +180.00

## Transforming the Pattern of a Pattern Key

- 1 From the top menu, select Key >M/E Key1 >Pattern Key.

The Pattern Key menu appears.

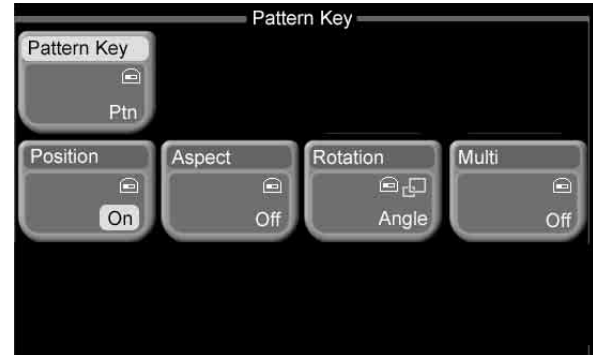

- 2 Press one of the following buttons, depending on what you want to adjust.

*For details about operation, see the sections on effect transformations (on the pages indicated in parentheses).*

**Position:** Change the key pattern position (*page 70*).

**Aspect:** Change the key pattern aspect ratio (*page 103*).

**Rotation:** Rotate the key pattern to a specified angle (*page 103*). Note that the parameter Magnitude is not available for pattern keys.

**Multi:** Arrange several examples of the same key pattern (*page 104*). When using a pattern key, operate in the same way as in “For a PGM/PST effect:” in the effect transformation procedure.

## Setting Key Mask Shapes and Positions

*See “Masking Part of a Key” (page 91) for more information about how to make basic key mask settings.*

- 1 From the top menu, select Key >M/E Key1 >Mask.  
The Mask menu appears.

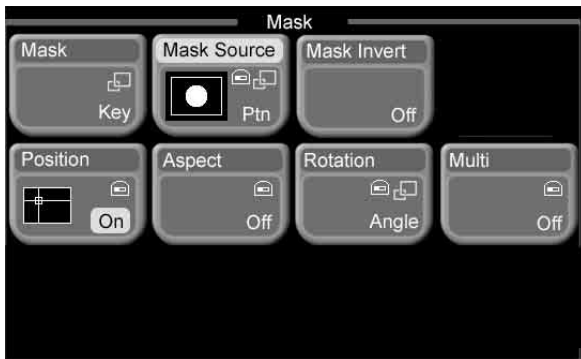

- 2 Press [Mask Source].

A popup window appears.



- 3 Select either of the following.

**Box:** Box-shaped mask signal

**Pattern:** Mask signal with the same pattern as a standard group effect pattern.

- 4 Set the following parameters, depending on the mask type selected in step 3.

**When Box was selected:**

Knob	Description	Setting values
1 (Left)	Position of left edge	-100.00 to +100.00
2 (Right)	Position of right edge	-100.00 to +100.00
3 (Top)	Position of top edge	-100.00 to +100.00
4 (Bottom)	Position of bottom edge	-100.00 to +100.00
5 (Soft)	Softness of edges	0.00 to 100.00

**When Pattern was selected:**

Knob	Description	Setting values
1 (Size)	Size of pattern	0.00 to 100.00
2 (Soft)	Softness of edges	0.00 to 100.00
3 (Pattern)	Pattern number	1 to 24 <sup>a)</sup>

a) Same as patterns in the standard group.

### To invert a mask signal

In the Key >M/E Key1 >Mask menu, press [Mask Invert], turning it on.

### To transform a mask pattern

In the Key >M/E Key1 >Mask menu, press one of the following buttons, depending on how you want to transform the pattern.

*For details about operation, see the sections on effect transformations (on the pages indicated in parentheses).*

**Position:** Change the mask pattern position (*page 70*).

**Aspect:** Change the mask pattern aspect ratio (*page 103*).

**Rotation:** Rotate the mask pattern to a specified angle (*page 103*). Note that the parameter Magnitude is not available for masks.

**Multi:** Arrange several examples of the same mask pattern (*page 104*). When using a mask, operate in the same way as “For a PGM/PST wipe”.

### Using the Show Key Function

Show key is a function to output, for a specified time or continuously, key-processed B&W signals from Edit PVW output.

Use the Setup/Diag >Operation >Key menu to enable and disable the show key function, and to make the settings for the enabled function.

*For details, see “Making show key settings” (page 222).*

### To output show key signals

In the key >M/E Key1 >Main menu, press [Show Key], turning it on.

Show key signals are output when the button lights. Output ends after the specified hold time.

You can stop show key output by pressing [Show Key] during the output.

### Using Key Memory

The key memory function allows the keyer settings on each cross-point button to be automatically stored, so that the next time the same cross-point button is selected these settings are recalled automatically.

### Key memory operating modes

There are two key memory operating modes: simple mode and full mode. Make a setup setting to select one of the modes.

The parameters stored differ as shown below, according to the operating mode.

#### Parameters stored in simple mode

- Key type
- Key inversion (Key Invert)
- Adjustment settings for the particular key type

- Luminance key and linear key: Clip, Gain, Density, and Filter settings, clean mode on and off.
- Chroma key: Settings excluding color cancel, Y balance, foreground video process, window, and shadow.
- Pattern key: Size, Soft, Density

### Parameters stored in full mode

All key settings, except for transitions

*On how to turn the key memory function on or off and select the key memory operating mode, see “Selecting the key memory operating mode” (page 221).*

### To recall settings stored in key memory

When the key memory function on, stored settings are recalled automatically at the same time that key signals are selected.

# Using an Effect for an Independent Key Transition

## Overview

Using a 1-channel DME effect pattern (in the 1000 range), you can carry out an independent key transition. Thus, for example, different effects can be applied to the background and key 1.

### Notes

- This requires the DME Board Set (MKS-2470) to be installed.
- An effect can be used for an independent key transition on an M/E key. For a downstream key independent key transition, effects cannot be used.
- Effects using DME cannot be selected on the same keys for an M/E transition and an independent key transition. For example, when one of the effects numbered 1001 to 1999 or 2001 to 2999 has already been selected on key 1 for an M/E transition, you cannot select any effect using DME on key 1 for an independent key transition.
- In the MFS-2000 system you can use two of the DME channels. So, when one of the DME effects numbered 2001 to 2999 is selected for an M/E transition, you cannot select any DME effect for an independent key transition on key 1 or key 2. And, when some effects are selected on key 1 and key 2 for independent key transitions, you can not use any effect using DME for M/E transitions.

### Effect patterns available for independent key transitions

Effect numbers	Group name
1001 to 1008	Slide
1011 to 1013	Split
1015 to 1020	Expansion
1021 to 1031	Squeeze
1041 to 1048	Door
1051 to 1069	2D Trans
1071 to 1094	3D Trans
1201 to 1208, 1221 to 1224, 1231, 1232	Frame In/Out
1301 to 1313, 1315 to 1318, 1341 to 1345	Page Turn
1321 to 1333, 1335 to 1338, 1346 to 1350	Page Roll
1351 to 1358	Mirror

Effect numbers	Group name
1361 to 1364	Accordion
1365 to 1369, 1501	Sphere
1371 to 1374	Character Trail
1375 to 1379	Wave
1381 to 1382	Ripple
1384 to 1389	Split Slide
1391 to 1399	Sparkle
1901 to 1999	User Programmable DME

## Assigning the Buttons Used (Setup)

Independent key transitions can also be controlled with the Flexi Pad control block.

For details, see “Using the Flexi Pad Control Block for an Independent Key Transition” (page 125).

### Assigning a key delegation to a utility control block button

In order to control an independent key transition effect in the Effect/Wipe control block, assign an independent key transition key delegation (M/E K1 Trans, M/E K2 Trans) to one of the utility control block buttons.

Operations in the Effect/Wipe control block apply to keys selected with these buttons.

For details of the assignment operation, see “Assigning utility commands” (page 218).

### Assigning the auto transition function to an M/E transition control block button (for a 1 M/E panel)

You can assign the auto transition function for an independent key transition to the [KEY1 ON] and [KEY2 ON] buttons of the M/E transition control block of an MKS-2010 control panel (1 M/E panel).

For details of the assignment operation, see “Assigning utility commands” (page 218).

## Selecting the Effect for an Independent Key Transition

The following procedure describes the case of setting for key 1. Use a similar procedure for key 2.

### Setting the transition type of an independent key transition to be an effect

**1** From the top menu, select Key >M/E K1 Trans >Main.

The Main menu appears.

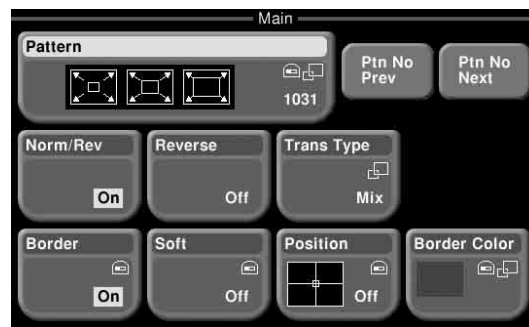

**2** Press [Trans Type].

A popup window appears.

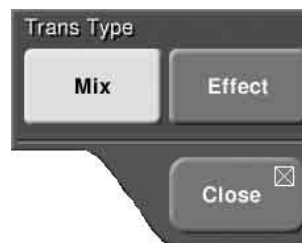

**3** Press [Effect].

The popup window closes, and the transition type of the independent key transition is set to “effect.”

### Selecting the effect pattern for an independent key transition

**1** Confirm that the transition type of an independent key transition is set to effect. (See previous item.)

**2** In the Key >M/E K1 Trans >Main menu, press [Pattern].

A popup window for selection of effect patterns appears.

**3** Use either of the following operations to select the effect pattern.

- Select the desired pattern by scrolling the popup window or from the group name.

See “Selecting Effects From Menus” (page 65).

- Enter the number of the desired pattern to make the selection.

See steps **3** and following in “To select effects with pattern numbers” (page 67).

## Making Detailed Settings for an Independent Key Transition Effect

### Effect modifiers

In the Main menu, you can make the following modifier settings. Carry out the operation in the same way as for a normal transition.

Setting	Button(s) to press	Reference page in User's Guide
Changing the position and size of the effect pattern	Position	72
Selecting effect directions	Norm/Rev, Reverse	78
Adding borders to video	Border	74
Setting border colors	Border Color	74
Softening borders or edges of video	Soft	75

### Advanced effect operations

Use the following menus for advanced effect operations. Carry out the operation in the same way as for a normal transition.

Setting	Menus (menu page numbers)	Reference page in User's Guide
Cropping effects	Key >M/E K1 (K2) Trans > Crop (1402/ 1502)	105
Adding beveled edges to video	Key >M/E K1 (K2) Trans >Beveled Edge (1403/1503)	106
Adding lighting	Key >M/E K1 (K2) Trans >Lighting (1404/1504)	108
Adding afterimages (Trail)	Key >M/E K1 (K2) Trans >Trail/Shadow (1405/1505)	109
Adding shadows around effects	Key >M/E K1 (K2) Trans >Trail/Shadow (1405/1505)	110
Selecting interpolation	Key >M/E K1 (K2) Trans	111

### Transformations specific to effect patterns

As for a normal transition, you can set the transformation parameters.

*For details, see "Effect Control Parameter List" (Appendix (separate volume), page 7).*

## Using the Flexi Pad Control Block for an Independent Key Transition

### Carrying out an Independent Key Transition With the Flexi Pad Control Block

This section explains procedures for operating M/E key 1. The same procedures can be used for M/E key 2 as well.

- 1 In the Flexi Pad control block, press the mode selection button assigned to M/E K1 Trans.

Beforehand you should assign the [M/E K1 TRANS] function to one of the mode selection buttons in the Flexi Pad control block.

*For details of the method of assignment, see "Changing the assignment of mode selection buttons in the Flexi Pad control block" (page 225).*

The display changes as shown in the following figure.

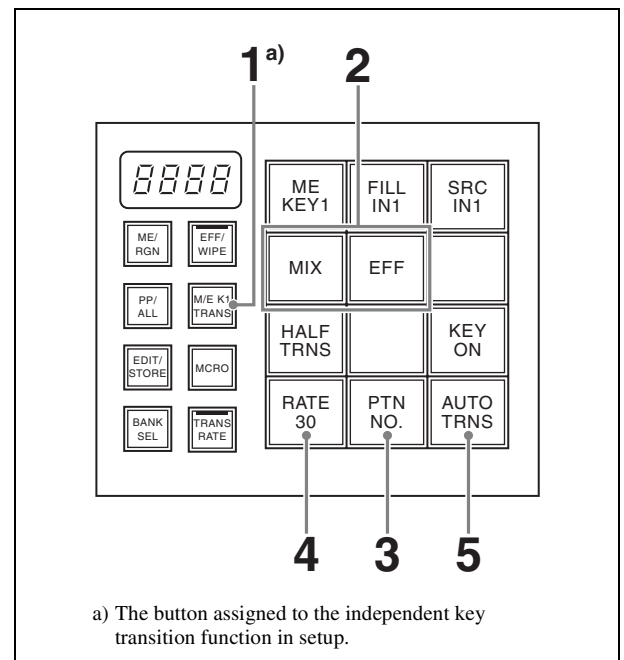

- 2 Press the [MIX] or [EFF] button to select the transition type.
- 3 To select effects, first press the [Pattern No.] button and then enter the number of the desired effect pattern.
- 4 To set transition rates, press the [TRANS RATE] button and then enter the transition rate as a number of frames.

**5** Press the [AUTO TRNS] button.

### To cut the key in or out instantaneously

Press [KEY ON].

### To make detailed settings for an effect

Press [HALF TRNS].

A key output as when the first half of the transition is completed is displayed.

Make detailed settings for an effect as required.

*For making detailed settings for an effect, see “Making Detailed Settings for an Independent Key Transition Effect” (page 125).*

#### Note

The [HALF TRNS] button is disabled during execution of a key auto transition.

---

## Color Correction

Color correction (CCR) enables input video color correction (black balance/white balance adjustment, gamma correction, knee correction, etc.).

#### Note

The following optional boards are required to use the color correction function.

- MKS-2420M Color Corrector Board
- MKS-2440 Frame Memory Board Set

The MKS-2420M is mounted on the MKS-2440.

---

## Selecting the Color Correction Signal

To apply color correction to a signal, capture the signal from the CCR1 bus or CCR2 bus.

The following signals can be selected from these buses.

- All primary inputs
- Frame memory video 1 to 3
- Frame memory key 1 to 3
- White
- Black
- Color background

### To select a signal

**1** Press the [CCR1] or [CCR2] AUX delegation button.

The cross-point button rows are assigned to the CCR1 bus or CCR2 bus.

**2** Press a button in a cross-point button row to select the desired signal.

The button lights in red (high tally) if the signal on the CCR1 bus or CCR2 bus is included in the program video (final output video). Otherwise it lights in amber (low tally).

---

## Output of Color Correction Results

You can assign signals to which color correction has been applied to cross-point buttons, and output the corrected signals by pressing those buttons.

*For details of the assignment process, see “Selecting Video” (page 55).*

---

## Flow of Color Correction Operations

Color correction is carried out in the following steps.

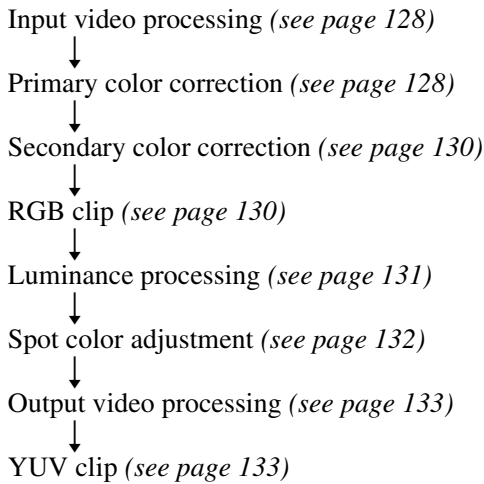

You can use two color correctors in each step. You can also mask part of the region to be corrected (*see page 129*).

## CCR Menu

For color correction operations, use the CCR menu.

### To access the CCR menu

- From the top menu, select CCR >CCR1 or CCR2.  
A popup window appears.



- Press the button for the menu you want to use, to display the menu.

**Input Process:** Input video processing (*see page 128*)

**Primary:** Primary color correction (*see page 128*)

**Secondary:** Secondary color correction (*see page 130*)

**RGB Clip:** RGB clip (*see page 130*)

**Lum Process:** Luminance process (*see page 131*)

**Spot:** Spot color adjustment (*see page 132*)

**Output Process:** Output video processing (*see page 133*)

**YUV Clip:** YUV clip (*see page 133*)

**Mask1:** Mask 1 (*see page 129*)

**Mask2:** Mask 2 (*see page 129*)

### To enable a color corrector

The following example shows how to enable color corrector 1 (CCR1). You can proceed in the same way to enable CCR2.

- From the top menu, select CCR >CCR1.
- Press a menu button other than [Mask1] or [Mask2] to display the menu.
- Press [CCR], turning it on.

This enables all of the functions of color corrector 1.

### To return all color corrector settings to the defaults

The following example shows how to proceed for color corrector 1 (CCR1). You can proceed in the same way for CCR2.

- From the top menu, select CCR >CCR1.
- Press a menu button other than [Mask1] or [Mask2] to display the menu.
- Press [Unity All].  
A message appears asking if you want to return all settings to the default settings.
- Press [Yes] in the message to return to the defaults, or [No] to cancel.

If you pressed [Yes], all color corrector settings are returned to the default settings.

### To copy or swap color corrector settings

- From the top menu, select CCR >Copy/Swap.

The Copy/Swap menu appears. The status area shows a copy source list (From) on the left and a copy destination list (To) on the right.

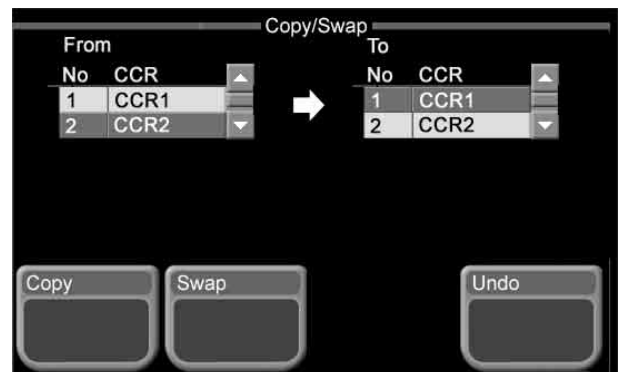

**2** Using any of the following methods, select the copy source color corrector and the copy destination color corrector.

- Press directly on the list in the status area.
- Use the arrow buttons to scroll the reverse video cursor.
- Turn the knobs.

Knob	Description	Setting values
1 (From No)	Copy source color corrector selection	1 or 2
4 (To No)	Copy destination color corrector selection	1 or 2

When you select either the source or destination color corrector, the other color corrector is selected automatically.

**3** Press [Copy] to execute a copy, or [Swap] to execute a swap.

### To undo a copy or swap

Press [Undo] in the Copy/Swap menu. The color correctors are restored to their states before the copy or swap.

## Input Video Processing

You can adjust the following for YUV signals.

- Overall video signal gain
- Y signal gain
- C signal gain
- Hue delay
- Black level

### To execute input video processing

Display the Input Process menu, then proceed as follows.

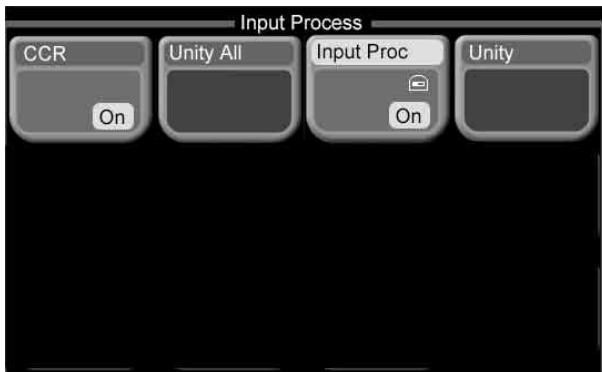

- 1** Press [Input Proc], turning it on.
- 2** Adjust the following parameters.

Knob	Description	Setting values
1 (Video Gain)	Overall video signal gain	-200.00 to +200.00
2 (Y Gain)	Y signal gain	-200.00 to +200.00
3 (C Gain)	C signal gain	-200.00 to +200.00
4 (Hue Delay)	Hue delay	-180.00 to +180.00
5 (Black Level)	Black level	-116.90 to +116.90

### To return input video processing parameters to their default settings

Press [Unity].

## Primary Color Correction

Adjust the following for RGB signals.

- Black balance
- White balance
- Gamma correction
- Knee correction

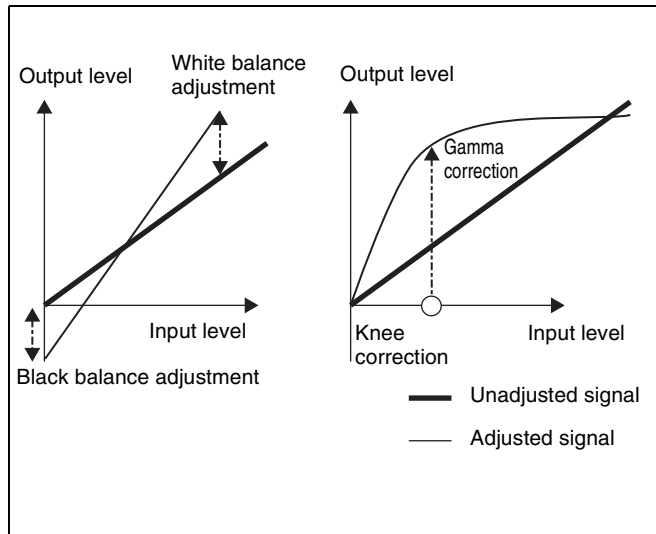

### To execute primary color correction

Display the Primary menu, and carry out the following operation.

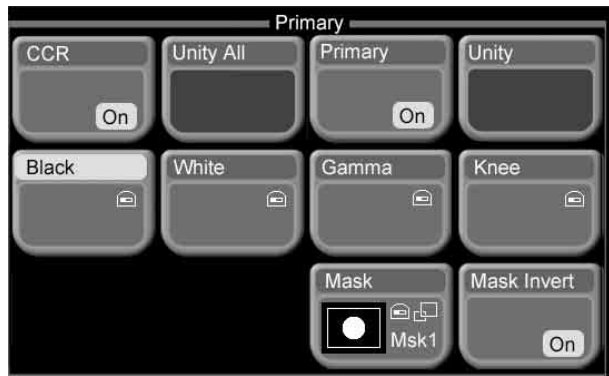

- 1** Press [Primary], turning it on.

- 2** As required, press the button for the adjustment you want to make, and turn the knobs to adjust the parameters.

**[Black]:**

Knob	Description	Setting values
1 (Red)	Black balance of R (red) signal	-100.00 to +100.00
2 (Green)	Black balance of G (green) signal	-100.00 to +100.00
3 (Blue)	Black balance of B (blue) signal	-100.00 to +100.00
4 (All)	Black balance of R, G, and B signals (adjusted at once)	Red value is shown

**[White]:**

Knob	Description	Setting values
1 (Red)	White balance of R (red) signal	0.00 to 200.00
2 (Green)	White balance of G (green) signal	0.00 to 200.00
3 (Blue)	White balance of B (blue) signal	0.00 to 200.00
4 (All)	White balance of R, G, and B signals (adjusted at once)	Red value is shown

**[Gamma]:**

Knob	Description	Setting values
1 (Red)	Gamma correction of R (red) signal	-100.00 to +100.00
2 (Green)	Gamma correction of G (green) signal	-100.00 to +100.00
3 (Blue)	Gamma correction of B (blue) signal	-100.00 to +100.00
4 (All)	Gamma correction of R, G, and B signals (adjusted at once)	Red value is shown

**[Knee]:**

Knob	Description	Setting values
1 (Red)	Knee correction of R (red) signal	20.00 to 75.00
2 (Green)	Knee correction of G (green) signal	20.00 to 75.00
3 (Blue)	Knee correction of B (blue) signal	20.00 to 75.00
4 (All)	Knee correction of R, G, and B signals (adjusted at once)	Red value is shown

**To return primary color correction parameters to their default settings**

Press [Unity].

**To mask part of the primary color correction**

**Note**

The mask function is common to the following color correction functions.

- Primary color correction
- Secondary color correction
- Luminance processing
- Spot color adjustment

For example, if in primary color correction you set mask 1 to a box, then in secondary color correction set mask 1 to a pattern, this also changes the setting in primary color correction to the pattern.

Here the procedure for mask 1 operation is described by way of example. You can carry out mask 2 operation in a similar way.

- 1** Press [Mask] in the Primary menu.

A popup window appears.



- 2** Press [Mask 1] to apply a mask.

- 3** Press the 3rd menu title button from the top.

A popup window (*see page 127*) appears.

- 4** Press [Mask 1].

The Mask 1 menu appears.

Note that the mask menu 1 can also be accessed from the CCR >CCR1 menu.

- 5** Set the mask source and mask pattern transformation method.

*For details about operation, refer to “Setting Key Mask Shapes and Positions” (page 121).*

- 6** Referring to “CCR Menu” (*page 127*), open the Primary menu.

- 7** Press [Mask] and adjust the following parameters.

**When Box was selected as the mask source:**

Knob	Description	Setting values
1 (Left)	Left edge position	-100.00 to +100.00
2 (Right)	Right edge position	-100.00 to +100.00

Knob	Description	Setting values
3 (Top)	Top edge position	-100.00 to +100.00
4 (Bottom)	Bottom edge position	-100.00 to +100.00
5 (Soft)	Degree of softness of box	0.00 to 100.00

When Pattern was selected as the mask source:

Knob	Description	Setting values
1 (H Position)	Horizontal position	-200.00 to +200.00
2 (V Position)	Vertical position	-200.00 to +200.00
3 (Size)	Pattern size	0.00 to 100.00
4 (Soft)	Degree of softness of pattern edge	0.00 to 100.00
5 (Pattern)	Pattern number	1 to 24

### To invert the mask source

Press [Mask Invert] in the Primary menu.

## Secondary Color Correction

You can adjust the following across a  $\pm 30^\circ$  range around the center point of the color, for each of six colors (red, green, blue, yellow, cyan, and magenta).

- Luminance
- Saturation
- Hue delay

### To execute secondary color correction

Display the Secondary menu, then proceed as follows.

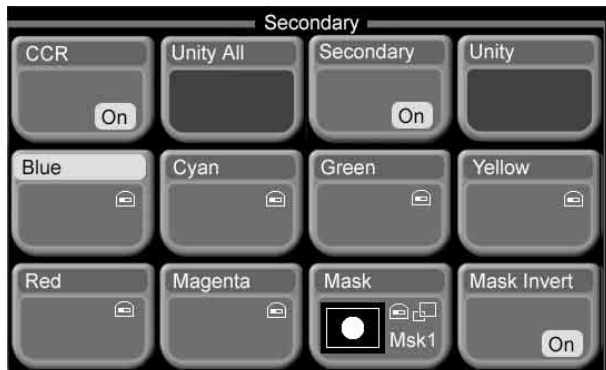

- 1 Press [Secondary], turning it on.
- 2 Press the button for the color to adjust ([Blue], [Cyan], [Green], [Yellow], [Red], or [Magenta]), then adjust the following parameters.

Knob	Description	Setting values
1 (Lum)	Luminance	-100.00 to +100.00
2 (Sat)	Saturation	0.00 to 200.00

Knob	Description	Setting values
3 (Hue Delay)	Hue delay	-180.00 to +180.00

### To return secondary color correction parameters to their default settings

Press [Unity].

### To mask part of the secondary color correction

Press [Mask] in the Secondary menu, turning it on. The proceed as explained in “To mask part of the primary color correction” (see page 129).

## RGB Clip

You can make the following adjustments for RGB signals.

- Dark clip (lower limit of signal level)
- White clip (upper limit of signal level)

### To execute RGB clip

Display the RGB Clip menu, then proceed as follows.

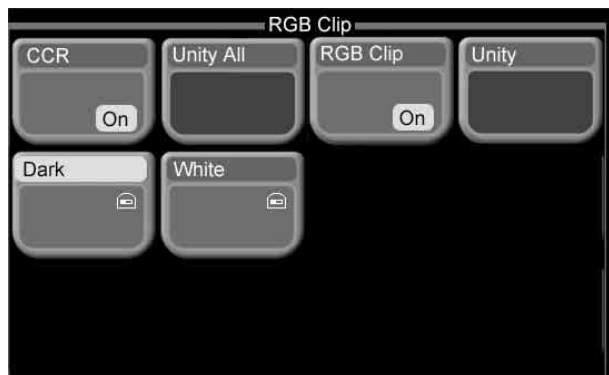

- 1 Press [RGB Clip], turning it on.
- 2 Press [Dark] or [White], then set the following parameters.

Knob	Description	Setting values
1 (Red)	Dark/white clip of R (red) signal	-50.00 to +149.99 <sup>a)</sup> -49.99 to +150.00 <sup>b)</sup>
2 (Green)	Dark/white clip of G (green) signal	-50.00 to +149.99 <sup>a)</sup> -49.99 to +150.00 <sup>b)</sup>
3 (Blue)	Dark/white clip of B (blue) signal	-50.00 to +149.99 <sup>a)</sup> -49.99 to +150.00 <sup>b)</sup>
4 (All)	Dark/white clip of R, G, and B signals (adjusted simultaneously)	-50.00 to +149.99 <sup>a)</sup> -49.99 to +150.00 <sup>b)</sup> Red value is shown

a) When [Dark] is selected

b) When [White] is selected

## To return RGB clip parameters to their default settings

Press [Unity].

## Luminance Processing

You can divide the luminance levels of YUV signals into three regions (Dark, Middle, and Bright), and adjust the video signals of each region separately.

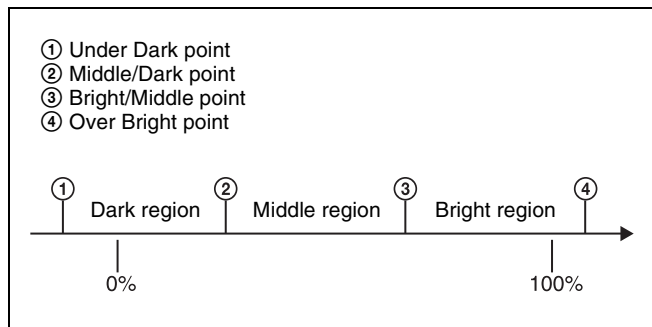

## To execute luminance processing

Display the Luminance Process menu, then proceed as follows.



**1** Press [Lum Proc], turning it on.

**2** Press [Mode].

A popup window appears so that you can select the adjustment mode.

**3** Depending on what you want to adjust, press one of the following to select an adjustment mode.

**Tint:** Add a specified color to the original video signal.

**Color Modify:** Adjust the original video signal.

**Y Modify:** Adjust the output levels of the input luminance signal.

**4** If you selected [Tint] or [Color Modify], proceed to step **5**. If you selected [Y Modify], adjust the following parameters.

Knob	Description	Setting values
1 (White)	White balance	0.00 to 200.00
2 (Black)	Black balance	-100.00 to +100.00
3 (Y Lift)	Curvature of luminance level curve	-100.00 to +100.00
4 (Y Dark)	Position of maximum point of luminance level curve	-7.30 to +109.58

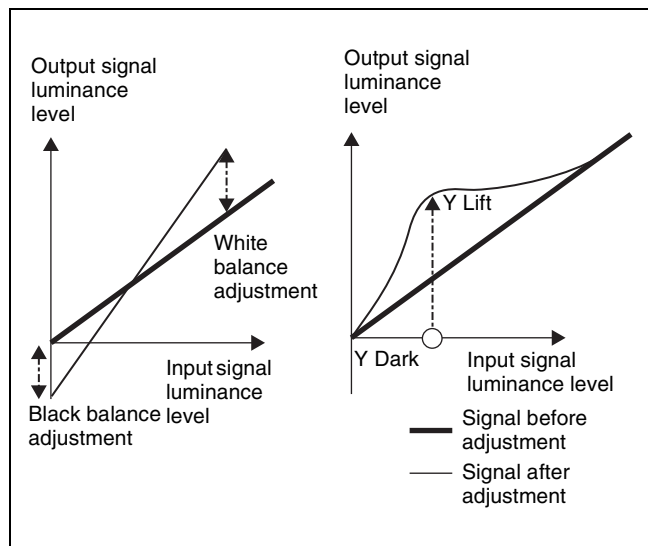

**5** Press [Bound Level] or [Bound Soft], and make settings for the three regions (Dark, Middle, Bright).

### [Bound Level] parameters:

Set the boundaries of the three regions.

Knob	Description	Setting values
1 (Over B Lvl)	Luminance level at upper limit of Bright region	50.00 to 150.00
2 (Mid B Lvl)	Luminance level at boundary between Bright and Middle regions	10.00 to 120.00
3 (D Mid Lvl)	Luminance level at boundary between Middle and Dark regions	-20.00 to +90.00
4 (Under D Lvl)	Luminance level at lower limit of Dark region	-50.00 to +50.00

### [Bound Soft] parameters:

Set the degree of boundary softness of the three regions.

Knob	Description	Setting values
1 (Over B Soft)	Degree of softness at upper limit of Bright region	15.00 to 70.00

Knob	Description	Setting values
2 (Mid B Soft)	Degree of softness at boundary between Bright and Middle regions	15.00 to 42.50
3 (D Mid Soft)	Degree of softness at boundary between Middle and Dark regions	15.00 to 42.50
4 (Under D Soft)	Degree of softness at lower limit of Dark region	15.00 to 70.00

- 6** Press [Dark], [Middle], or [Bright] to select a region, then adjust the following parameters.

#### Tint mode:

Knob	Description	Setting values
1 (Lum)	Luminance	-100.00 to +100.00
2 (Sat)	Saturation	0.00 to 100.00
3 (Hue)	Hue	359.99 to 0.00

#### Color modify mode:

Knob	Description	Setting values
1 (Lum)	Luminance	-100.00 to +100.00
2 (C Gain)	C signal gain	0.00 to 200.00
3 (Hue Delay)	Hue delay	-180.00 to +180.00

#### To return luminance processing parameters to their default settings

Press [Unity].

#### To mask part of the luminance processing

Press [Mask] in the Luminance Process menu, turning it on. Then proceed as explained in “To mask part of the primary color correction” (see page 129).

## Spot Color Adjustment

You can change the color in a specified region to another color, without affecting other regions. You can also adjust the following in the regions outside the spot color adjustment region.

- Video signal overall gain
- Y signal gain
- Y signal offset
- C signal gain
- C signal hue delay

#### To execute spot color adjustment

Display the Spot menu, then proceed as follows.

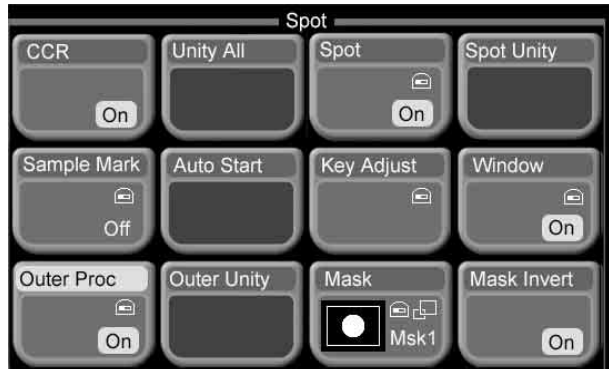

- 1** Press [Spot], turning it on.

- 2** Press [Sample Mark], turning it on.

When [Sample Mark] is on, the effects of color adjustment outside the region of spot color adjustment and output video processing are temporarily disabled. (Turning [Sample Mark] off restores the former state.)

- 3** Adjust the following parameters so that the color you want to change is included within the sample mark.

Knob	Description	Setting values
1 (H Position)	Horizontal position	-100.00 to +100.00
2 (V Position)	Vertical position	-100.00 to +100.00
3 (Size)	Size	1.00 to 100.00

- 4** Press [Auto Start], to adjust the key automatically.

#### Note

This automatic adjustment does not carry out key gain adjustment. If required, adjust the key gain as shown in step 5.

- 5** Press [Key Adjust], then adjust the following key parameters.

Knob	Description	Setting values
1 (Lum)	Luminance	-7.31 to +109.59
2 (Sat)	Saturation	0.00 to 100.00
3 (Hue)	Hue	359.99 to 0.00
4 (Gain)	Key gain	-100.00 to +100.00

- 6** Press [Window], turning it on., to adjust the key detection range for spot color adjustment.

Knob	Description	Setting values
1 (Lum)	Luminance	0.00 to 100.00
2 (Sat)	Saturation	0.00 to 100.00
3 (Hue)	Hue	0.00 to 100.00

7 Press [Spot], and adjust the replacement color.

Knob	Description	Setting values
1 (Lum)	Luminance	-7.31 to +109.59
2 (Sat)	Saturation	0.00 to 100.00
3 (Hue)	Hue	359.99 to 0.00

### To return spot color adjustment parameters to their default settings

Press [Spot Unity].

### To mask part of the spot color adjustment

Press [Mask] in the Spot menu, turning it on. Then proceed as explained in “To mask part of the primary color correction” (see page 129).

### To adjust colors outside the spot color adjustment region

- 1 With [Spot] on in the Spot menu, press [Outer Proc], turning it on.
- 2 Adjust the following parameters.

Knob	Description	Setting values
1 (Video Gain)	Overall gain of video signal	-200.00 to +200.00
2 (Y Gain)	Y signal gain	-200.00 to +200.00
3 (C Gain)	C signal gain	-200.00 to +200.00
4 (Hue Delay)	Hue delay	-180.00 to +180.00
5 (Black Level)	Black level	-116.90 to +116.90

### To return [Outer Proc] parameters to their default settings

Press [Outer Unity].

## Output Video Processing

You can adjust the following for YUV signals.

- Overall gain of video signal
- Y signal gain
- Y signal offset
- C signal gain
- C signal hue delay

### To execute output video processing

Display the Output Process menu, then proceed as follows.

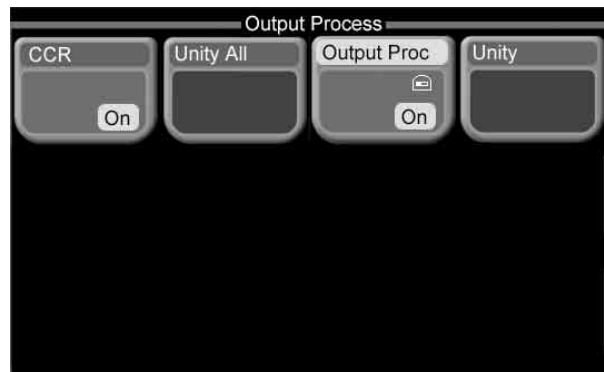

- 1 Press [Output Proc], turning it on.
- 2 Adjust the following parameters.

Knob	Description	Setting values
1 (Video Gain)	Overall gain of video signal	-200.00 to +200.00
2 (Y Gain)	Y signal gain	-200.00 to +200.00
3 (C Gain)	C signal gain	-200.00 to +200.00
4 (Hue Delay)	Hue delay	-180.00 to +180.00
5 (Black Level)	Black level	-116.90 to +116.90

### Note

When [Sample Mark] in the Spot menu is on, the effects of color adjustment outside the region of spot color adjustment and output video processing are temporarily disabled.

Turning [Sample Mark] off restores the former state.

### To return output video processing parameters to their default settings

Press [Unity].

## YUV Clip

You can adjust the following for luminance signals and color difference signals.

- White clip (Upper limit of luminance signal level)
- Dark clip (Lower limit of luminance signal level)
- Positive clip (Maximum amplitude in positive direction of color difference signal)
- Negative clip (Maximum amplitude in Negative direction of color difference signal)

### To execute YUV clip

Display the YUV Clip menu, then proceed as follows.

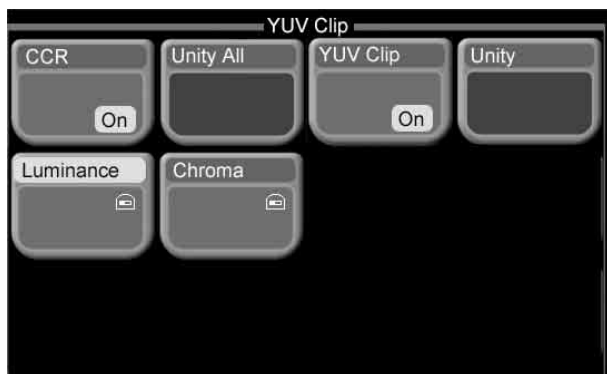

- 1 Press [YUV Clip], turning it on.
- 2 Depending on the signal you want to adjust, press one of the following to select the target for adjustment.

**Luminance:** Luminance signal

**Chroma:** Color difference signal.

- 3 Adjust the following parameters for the signal selected in step 2.

#### Luminance:

Knob	Description	Setting values
1 (White Clip)	White clip	-6.85 to +109.13
2 (Dark Clip)	Dark clip	-6.85 to +109.13

#### Chroma:

Knob	Description	Setting values
1 (U Posi Clip)	Positive clip adjustment for U signal	-113.39 to +113.39
2 (U Nega Clip)	Negative clip adjustment for U signal	-113.39 to +113.39
3 (V Posi Clip)	Positive clip adjustment for V signal	-113.39 to +113.39
4 (V Nega Clip)	Negative clip adjustment for V signal	-113.39 to +113.39

#### To return YUV clip parameters to their default settings

Press [Unity].

## Frame Memory (Still Image File)

Frame memory is a function whereby a frame of input video can be frozen and written to memory, for further use as material for editing.

### Overview

#### How many images can be stored in frame memory

The maximum number of images that can be written to memory is as follows.

Video format	Memory capacity
480i/59.94	2830
576i/50	2402
1080i/50	514
1080i/59.94	514
1080PsF/23.976	514
1080PsF/24	514
1080PsF/25	514
1080PsF/29.97	514
720P/50	1160
720P/59.94	1160

#### Hardware and software requirements for using frame memory

To use frame memory, the switcher system requires the following options.

- MKS-2440 Frame Memory Board Set
  - BZS-2440M Frame Memory Upgrade Software
- However, the BZS-2440M software is not required when the signal format is 480i or 576i.

#### About terminology

This manual refers to target images of editing operations in the following ways, depending on the frame memory operation by which they are obtained.

**Freeze image:** An image that has been frozen but not stored (not saved in memory).

**Still image:** An image that has been frozen and stored (saved in memory).

**Frame memory clip (clip):** A set of consecutive still images which look like an animation when played back sequentially. In this manual, it is called a “clip” and the set of still image files of a clip is called a “clip file”.

There are generically called “images” hereafter where

strict distinction is not necessary. When these distinctions are not relevant, we call them “images” collectively hereafter.

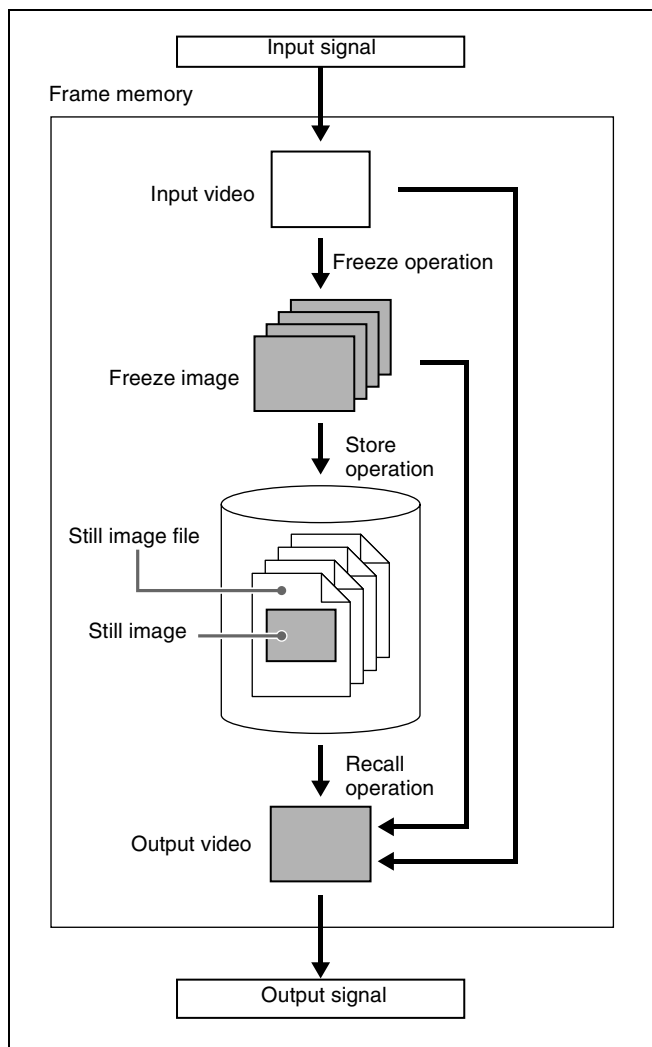

## Flow of Frame Memory Operations

The flow of frame memory operations is as follows.

### When still images are created one at a time

Assign frame memory output to a cross-point.

↓  
Select the input signal (video before freeze, etc.). (See page 135.)

- Freeze the video at the desired point and save in frame memory as a still image file. (See page 136.)
- Compose video from frame memory input and output, and save in frame memory as a still image file. (See page 138).

↓  
Recall a desired still image from a still image file saved in memory. (See page 137.)

### When images are created sequentially (animation)

Assign frame memory output to a cross-point.

↓  
Select the input signal (video before freeze, etc.). (See page 135.)

↓  
Record a series of freeze images, and save them in frame memory as still image files. (See page 141).

↓  
Load a series of still image files saved in frame memory. (See page 142).

### In both of the above cases, do the following as required.

- Reposition the output video on the screen. (See page 140).
- Rename (see page 146) or delete (see page 147) a still image file saved in memory.

## Preparations

### Assigning frame memory output to cross-point buttons

Frame memory images (freeze images, etc.) can be assigned to either the video or key channels of frame memory 1 to 3.

The following three types of output destinations are available (six channels).

- FM 1 Video and FM 1 Key
- FM 2 Video and FM 2 Key
- FM 3 Video and FM 3 Key

Before using frame memory images, you need to assign one or more of the six channels listed above to cross-point buttons.

You can assign channels in pairs. For example, if you assign FM 1 Video and FM 1 Key as a pair, you can select both the video and the key with the same cross-point button.

*For details about assignment operations, refer to “Assigning Signals to Cross-Point Buttons (Operation Menu)” (page 204).*

### Selecting Input Signals for Frame Memory

Select the signal (video, etc.) to be processed with frame memory.

There are two buses for selecting input video signals.

**Frame memory video bus:** Allows the frame memory video input signal to be selected.

**Frame memory key bus:** Allows the frame memory key input signal to be selected.

- 1 In the AUX bus control block of the control panel, press the AUX delegation button [FRAME MEM], turning it on.
- 2 Switch the [SRC BUS] button in the AUX bus control block as follows.
  - To select the video input signal, turn the [SRC BUS] button off.  
The auxiliary bus switches to the frame memory video bus. In this case, the key assigned as a pair to the selected video is automatically selected on the frame memory key bus.
  - To select the key input signal, turn the [SRC BUS] button on.  
The auxiliary bus switches to the frame memory key bus. In this case, you can select the key independently of the video.
- 3 Select the desired signal in the cross-point button rows of the AUX bus control block.

The selected signal is input to frame memory.

## Freezing Images and Saving Them to Memory

- 1 From the top menu, select Frame Memory> Freeze.  
The Freeze menu appears.

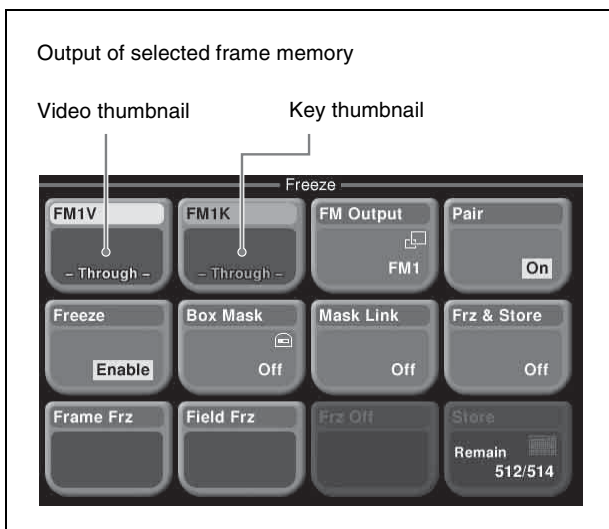

- 2 To change the frame memory output destination (FM1 in the above figure), press [FM Output].  
*For details, see “To select frame memory output” (page 137).*
- 3 To operate on video and key as a pair, press [Pair], turning it on.

- 4 When [Pair] is turned off in step 3, press one of the output buttons (in the above figure, [FM1V] or [FM1K]) to select the target.

The selected button turns light blue.

- 5 Press [Freeze] to display “Enable”.  
A freeze frame can now be captured.
- 6 If required, apply a mask to the selected signal. (*See “To apply a box-shaped mask to a freeze image” (page 137).*)
- 7 At the point you want to freeze, press one of the following.

**Frame Frz:** Freeze an image frame.

**Field Frz:** Freeze an image field.

### Note

In the following signal formats, a field freeze is not possible.

1080PsF/23.976, 1080PsF/24, 1080PsF/25, 1080PsF/29.97, 720P/50, 720P/59.94

This freezes the input video.

In this state, no freeze image has yet been saved. You can repeat this operation any number of times, until the desired freeze image is obtained.

- 8 When you have obtained the freeze image you want, press [Store] in the Freeze menu, and confirm the name in the keyboard window.

*For details of the saved file names, see the next item, “File names”.*

If, before saving the freeze image, you press [FM Output] to switch the frame memory, the freeze image is saved automatically in frame memory. (Automatic save)

The freeze image is saved in memory, and a thumbnail for the video and/or key appears.

The “Remain” count under [Store], showing the number of images that can be saved, decreases by one (or by two if [Pair] is turned on in step 3).

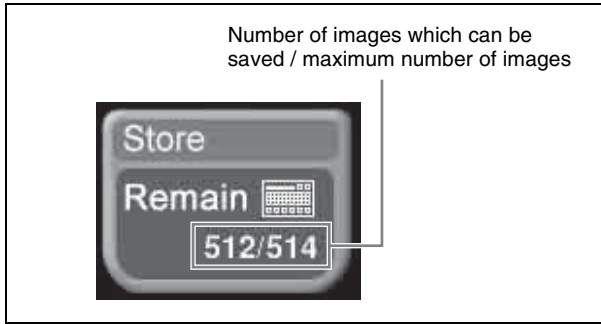

**Note**

Saved still images are erased if you power off the switcher, or execute a reset with the Setup/Diag >System >Initialize menu. Still images which you do not want to erase must be saved as files to the hard disk or a “Memory Stick”. (See Chapter 7 “File Operations” (page 179).)

**File names**

- When you press [Store], a keyboard window appears, and the default file name, such as “image001” appears. To change this, enter the file name in the keyboard window. (Maximum eight alphanumeric characters)
- If the specified file name already exists, an overwriting confirmation message appears. Select “Yes” to overwrite the data.
- For automatic saving, the file name is automatically set to “auto\_000”, “auto\_001”, and so on.
- For a key file, “(k)” is automatically appended to the file name.
- The following names cannot be used:  
CON, PRN, AUX, CLOCK\$, NUL, COM0, COM1, COM2, COM3, COM4, COM5, COM6, COM7, COM8, COM9  
LPT0, LPT1, LPT2, LPT3, LPT4, LPT5, LPT6, LPT7, LPT8, LPT9

**Carrying out a freeze and store simultaneously**

Press [Frz & Store], turning it on.

The system enters the freeze and store mode.

In this state, if you press [Frame Frz] or [Field Frz], this carries out a freeze, and simultaneously stores it in a still image file.

**Saving files with [Pair] on/off**

When saving with [Pair] turned off, a file is created for either the video or key. (Referred to below as an “Single file”.)

When [Pair] is turned on, both video and key files are created with the same name. (Referred to below as “Pair files”.)

**To apply a box-shaped mask to a freeze image**

- 1 To link the video and key with a mask, press [Mask Link] in the Freeze menu, turning it on.

- 2 When [Mask Link] is turned off in step 1, press one of the output buttons ([FM1V] or [FM1K] in the example display of the Freeze menu on page 136), to select it.

The selected button turns light blue.

**Note**

Even when [Pair] is on, if [Mask Link] is off, you can apply different masks to the video and key. In this case, press the output button to select it for the operation.

- 3 Press [Box Mask], turning it on.

- 4 Set the parameters for the four sides of the box.

Knob	Description	Setting values
1 (Left)	Left edge position	-100.00 to +100.00
2 (Right)	Right edge position	-100.00 to +100.00
3 (Top)	Top edge position	-100.00 to +100.00
4 (Bottom)	Bottom edge position	-100.00 to +100.00

(If you turned [Mask Link] on in step 1, the parameters for video side are shown.)

**To select frame memory output**

- 1 Press [FM Output].

A popup window appears.



- 2 Press one of the following.

**FM1 V/K:** Frame memory 1 video and key

**FM2 V/K:** Frame memory 2 video and key

**FM3 V/K:** Frame memory 3 video and key

For example, if you select [FM2 V/K], the thumbnails in the Freeze menu (see page 136) change to [FM2V] and [FM2K].

**To delete a freeze image**

Press [Frz Off]. The thumbnails in the Freeze menu ([FM1V] and [FM1K] in the figure on page 136) change to black.

**Recalling Still Images Saved in Frame Memory**

- 1 From the top menu, select Frame Memory >Recall.

The Recall menu appears.

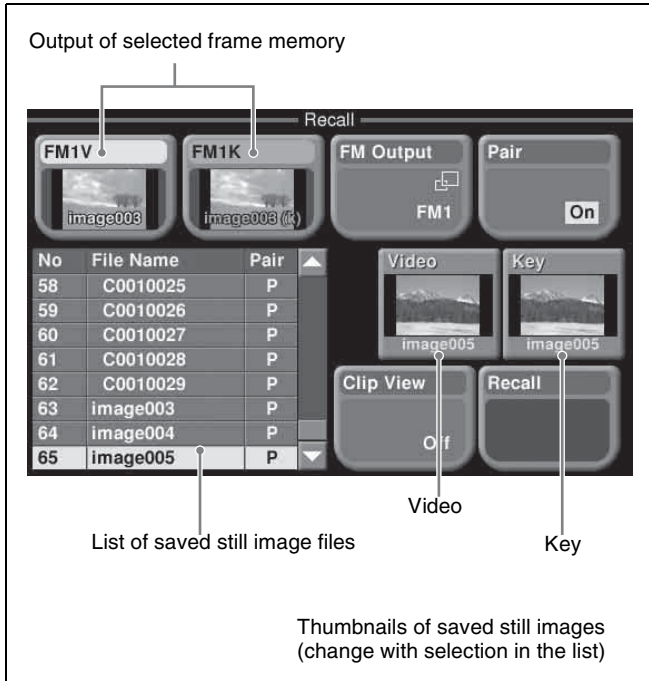

- 2** To change the frame memory output destination ([FM1] in the above figure), press [FM Output].

For details, see “To select frame memory output” (page 137).

- 3** Press [Clip View], turning it off.
- 4** Press [Pair], turning it on/off.

The selection for operation changes as follows.

**On:** Only Pair files appear in the list, and the operation applies simultaneously to the video and key files.

**Off:** The list shows both Pair files and Single files, and operations apply separately to the video and key files.

About Single files and Pair files, see “Saving files with [Pair] on/off” (page 137).

- 5** When [Pair] is turned off, press one of the output buttons, to select it for the operation.
- The selected button turns light blue.
- 6** Do one of the following to select the still image file to recall.
- Press directly on the list appearing in the status area.
  - Press the list arrow buttons.
  - Use the knob or buttons.

Knob/button	Description	Setting values
1 (No)	File number	1 to number of saved image files
3 (Back)	Jump to the previous file. <sup>a)</sup>	–
4 (Fwd)	Jump to the next file. <sup>a)</sup>	–

a) The files whose names are indented are skipped.

Still image selection in the list is reflected in thumbnail selection, and vice versa.

- 7** If [Pair] is off, press the [Video] or [Key] thumbnail to select the target.

The selected button turns light blue.

- 8** Press [Recall].

This recalls the still image, which appears in [FM1V] and/or [FM1K].

## Composing Frame Memory Video

You can make composites from the following inputs (composite function).

**Background video:** Freeze images and still images assigned to frame memory output, or a black signal.

**Foreground video:** The input signal selected for the frame memory input bus, or a single-color matte signal.

- 1** From the top menu, select Frame Memory >Still Edit >Composite.

The Composite menu appears.

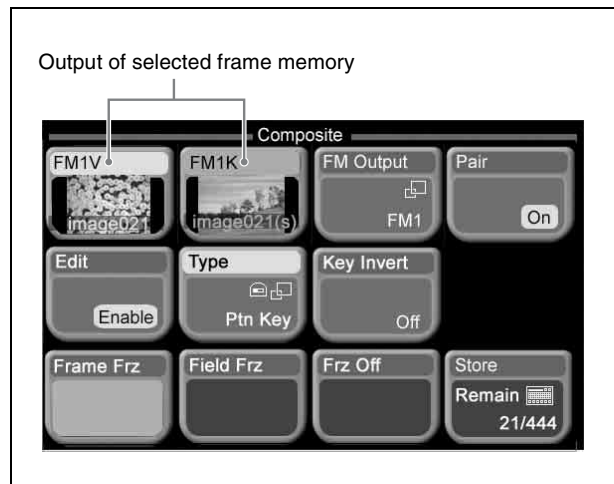

- 2** Set the following items, as required.

- FM Output: Frame memory output destination (see “To select frame memory output” (page 137)).

- Pair: Select whether or not to operate with both the video and key files (see steps 3 to 4 in “Recalling Still Images Saved in Frame Memory” (page 137)).

**3** Press [Edit], setting it to Enable.

This enables composition of the background and foreground video.

**Note**

The background video and foreground video move down one line, but they are frozen at the correct positions when you execute a freeze operation.

**4** To use a single-color matte signal as the foreground video, press [Frgd Color] in the Frame Memory > Still Edit > Composite Adjust menu, turning it on. Then press [Color Adjust], select the desired color from the popup window which appears, and turn the knobs to adjust the following parameters.

Knob	Description	Setting values
1 (Lum)	Luminance	0.00 to 100.00
2 (Sat)	Saturation	0.00 to 100.00
3 (Hue)	Hue	359.99 to 0.00

**5** If you set [Frgd Color] to Off in step 4, you can apply a mask with the Composite Adjust menu.

See “To apply a box-shaped mask to a freeze image” (page 137) for the procedure.

**6** To use black as the background video, press [Bkgd Black] in the Frame Memory > Still Edit > Composite Adjust menu, turning it on.

**Note**

If the background video was black originally, [Bkgd Black] is set to On automatically and cannot be changed.

If the background signal is a freeze image, it is erased when you set [Bkgd Black] to On. The [Bkgd Black] setting is now fixed as On, and it is not possible to return to the freeze image.

**7** Select the composition type (see the next section).

**8** Freeze the video, and save the freeze image in frame memory.

See steps 7 and 8 in “Freezing Images and Saving Them to Memory” (page 136) for more information about this operation.

## Selecting the composition type

**1** In the Composite menu, press [Type].

A popup window appears.



**2** Do one of the following to select the composition type.

**Off:** No composition. Only the background video is output.

**Pattern Key:** Use a signal generated by the system’s pattern generator to cut out the background video, and inset the signal selected on the frame memory source bus or a color matte signal. You can adjust the size and position of the pattern, and set a modifier.

**External Key:** When you process the video with FM1V (2V, 3V), the signal selected on frame memory source bus 1 Key is used to cut out the background video, and the signal selected on frame memory source bus 1 Video or a color matte signal is inserted.

When you process the video with FM1K (2K, 3K), the signal selected on frame memory source bus 1K is used to cut out the background video, and a color matte signal (fixed as White) is inserted.

**Note**

[External Key] can be selected only when [Pair] is set to On.

**Mix:** The background video is mixed with the signal selected on the frame memory source bus, or with a color matte signal. You can adjust the mix ratio.

**NAM:** The background video is mixed by a Non-Additive Mix <sup>1)</sup> with the signal selected on the frame memory source bus, or with a color matte signal.

1) Non-Additive Mix: The luminance of the background video is compared with the luminance of the foreground video, and the video with the higher luminance is output. There are no parameters to adjust.

**3** Set the following parameters, according to the type selected in step 2.

- When [Pattern Key] is selected:

Knob	Description	Setting values
1 (Size)	Size of pattern	0.00 to 100.00
2 (Soft)	Softness of edges	0.00 to 100.00
3 (Pattern)	Pattern number	1 to 24 <sup>a)</sup>

a) Same as patterns in the standard group.

- When [External Key] is selected:

Knob	Description	Setting values
1 (Clip)	Key signal generation reference level	+109.59 to -7.31
2 (Gain)	Key gain	-100.00 to +100.00

- When [Mix] is selected:

Knob	Description	Setting values
1 (Mix Rate)	Mix ratio	0.00 to 100.00

4 If you selected [Pattern Key] or [External Key], press [Key Invert], turning it on, to invert the key.

5 When [Pattern Key] is selected, set the following parameters as required in the Frame Memory > Still Edit > Composite Adjust menu.

- After pressing [Pattern Sel] to enable pattern selection

Knob	Description	Setting values
1 (Size)	Size of pattern	0.00 to 100.00
2 (Soft)	Softness of edges	0.00 to 100.00
3 (Pattern)	Pattern number	1 to 24 <sup>a)</sup>

a) Same as patterns in the standard group.

- After setting [Position] to On, to set the pattern position

Knob	Description	Setting values
1 (H Position)	Horizontal position	-100.00 to +100.00 <sup>a)</sup>
2 (V Position)	Vertical position	-100.00 to +100.00 <sup>b)</sup>

a) Minus values move the wipe to the left, and plus values move it to the right.

b) Minus values move the wipe down, and plus values move it up.

- After setting [Aspect] to On, to set the pattern aspect ratio

Knob	Description	Setting values
1 (Aspect)	Aspect ratio	-100.00 to +100.00 <sup>a)</sup>

a) Minus values make the pattern taller in the vertical direction, and plus values make it wider in the horizontal direction.

- After setting [Angle] to On, to adjust the pattern slant

Knob	Description	Setting values
1 (Angle)	Angle of pattern slant	-100.00 to +100.00 <sup>a)</sup>

a) -100.00 is one rotation in the counterclockwise direction, and +100.00 is one rotation in the clockwise direction.

- After setting [Multi] to On, to use multiple instances of the pattern

Knob	Description	Setting values
1 (H Multi)	Number of patterns arranged horizontally	1 to 63
2 (V Multi)	Number of patterns arranged vertically	1 to 63
3 (Invert Type)	Replication layout	1 to 4 <sup>a)</sup>

a) A popup window opens if you press knob 3.



1: All patterns point in same direction

2: Even numbered rows move in horizontal direction

3: Even numbered columns and rows are inverted

4: Even numbered columns and rows are inverted, and even numbered rows move in horizontal direction

## Changing the Screen Position of the Output Video

You can move the output video relative to the screen (the reposition function).

### Note

Images moved with the position functions cannot be written directly to frame memory.

1 From the top menu, select Frame Memory > Reposition.

The Reposition menu appears.

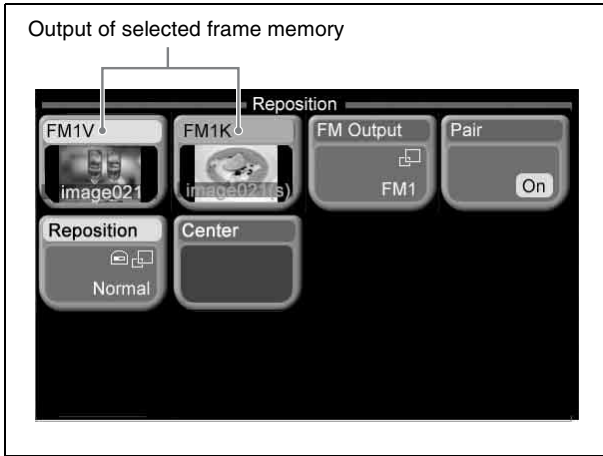

**2** Set the following items as required.

- FM Output: Frame memory output destination (see “To select frame memory output” (page 137)).
- Pair: Select whether or not to operate with both the video and key files (see steps **3** to **4** in “Recalling Still Images Saved in Frame Memory” (page 137)).

**3** Press [Reposition].

A popup window appears.



**4** Press one of the following to select the movement unit.

**Off:** Do not move the output video.

**Normal:** Move horizontally in 2-pixel units, with no color change.

**Fine:** Move in horizontally in 1-pixel units, and invert the color at each successive pixel.

**5** Move the output video by turning the knobs to adjust the following parameters.

Knob	Description	Setting values
1 (H Position)	Horizontal movement	-200.00 to +200.00
2 (V Position)	Vertical movement	-200.00 to +200.00

The vicinity of an image moved on the screen becomes black.

**To return a moved image to the center position**  
Press [Center].

## Recording a Series of Images in Frame Memory

You can capture (freeze) a series of images for a specified duration and save the images to frame memory (record function).

### Notes

The mask function cannot be used while recording a series of images.

**1** From the top menu, select Frame Memory > Animation > Record.

The Record menu appears.

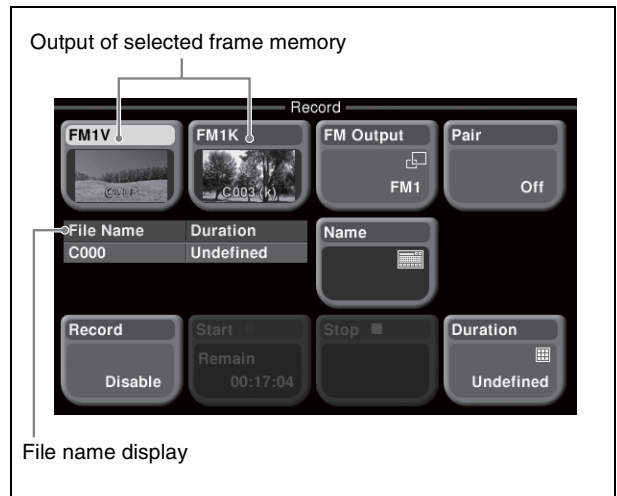

**2** Set the following items as required.

- FM Output: Frame memory output destination (see “To select frame memory output” (page 137)).
- Pair: Select whether or not to operate with both the video and key files (see steps **3** to **4** in “Recalling Still Images Saved in Frame Memory” (page 137)).

### Note

When [Pair] is off, even if the key images are selected, those images are recorded as the video files.

**3** Press [Record], setting it to Enable.

This enables execution of the record function.

**4** Set the recording duration as required.

The numeric keypad window appears when you press [Duration] in timecode. Enter the recording duration in units of frames.

Set the recording duration to 0 to use all available frame memory.

**Note**

It is not possible to set a recording time that exceeds the number of frames that can be saved in the remaining frame memory (*see step 6*).

- To set the file name, press [Name] to enter it with a keyboard window.

The upper four-digits of the file name can be entered.

For the default file name, see “About file names” in step 6.

- Press [Start] to start recording.

The status display area of the [Start] button shows the number of frames that can be saved in the remaining memory.

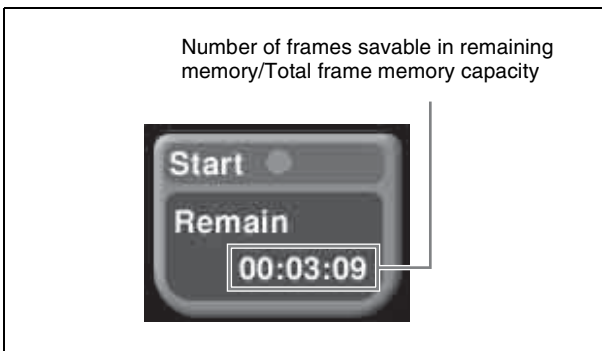

If a recording duration is specified, recording stops after that duration.

**About file names**

During recording, “- Rec -” appears in the status display area of the frame memory output buttons. The name of the file saved as a result of the recording comprises of up to eight characters. But only upper four digits of the name are displayed in the file name display. (The lower four digits are not displayed.) The lower four digits are a number from 0000 to 9999, which increases by 1 with each recording operation. The upper four digits are modifiable.

- Press [Stop] to stop recording.

Even when a duration is set, you can stop before the duration is reached.

## Recalling Recorded Still Images Sequentially

You can create and execute a timeline effect using still images captured by the record function as keyframes. This allows you to recall the entire series in one operation (animation function).

**Notes**

- Always include frame memory in the Misc region configuration. Timeline effects cannot be created or recalled unless frame memory is included. For details, see “Setting the regions included in “Misc”” (page 225).
- Frames are recorded in units of one frame, but are played back in units of 2 frames through the animation created with the Create Timeline menu.

## Creating a timeline effect by using still images as keyframes

- From the top menu, select Frame Memory > Animation > Create Timeline.

The Create Timeline menu appears.

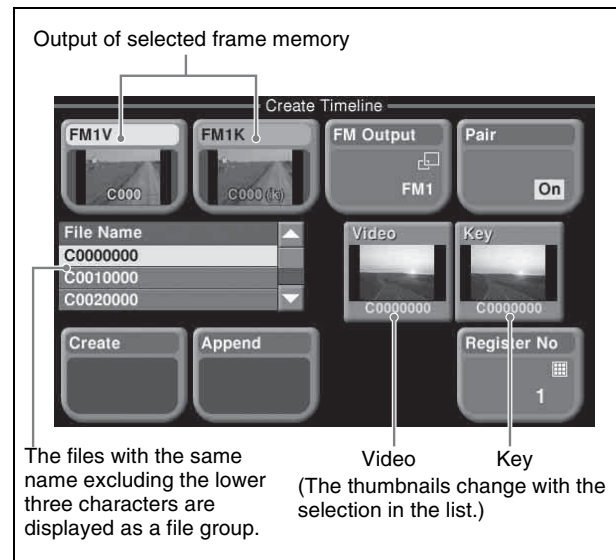

- Set the following items as required.

- FM Output: Frame memory output destination (*see “To select frame memory output” (page 137)*).
- Pair: Select whether or not to operate with both the video and key files (*see steps 3 to 4 in “Recalling Still Images Saved in Frame Memory” (page 137)*).

When [Pair] is set to On, only pair files (sets of main file and sub files) appear in the list in the status area. When [Pair] is set to Off, all single files and pair files appear.

- When [Pair] is set to Off, press one of the output buttons to select the target of the operation.

The selected button turns light blue.

- Press [Register No].

The numeric keypad window appears.

**5** Enter the number of a register (1 to 99) to save the keyframes, and then press [Enter].

The selected register number appears in the status display area of the [Register No] button.

**Note**

Register numbers which are already recalled to the timeline cannot be selected.

**6** Use the arrow buttons or knob 1 to scroll the list, stopping when the list appears for the group of files that you want to use as keyframes.

Knob	Description	Setting values
1 (Scroll)	Scroll file list	1 and upwards

**7** Turn knob 3 as required to select a timeline effect, checking the animation of the thumbnail display.

Knob	Description	Setting values
3 (Viewer)	Animate the file group thumbnail	0 and upwards

**8** Do one of the following.

- Clear the register selected in step **4** and recreate the timeline: Press [Create].
- Append the timeline effect to the register selected in step **4**: Press [Append].

A message appears asking you to confirm creation of the timeline.

**9** Press [Yes] to execute the timeline creation, or [No] to cancel it.

If you pressed [Yes], creation of the timeline begins and a window opens to show its progress. A completion message appears when processing finishes. Press [OK] to close the message window.

**Note**

For the current timeline, the Misc region register only is replaced by the register whose number was specified in steps **4** and **5**. To perform a timeline operation, recall the register again.

If you pressed [No], creation of the timeline is cancelled.

**Note**

The maximum number of still images that can be played in one animation is 99 (when [Pair] is set to On, 99 pair files).

See “Executing a Timeline Effect” (page 168) for more information about this operation.

### Recalling still images sequentially

Execute the timeline effect created with the previous procedure.

# Frame Memory (Clip)

## Overview

The images stored in frame memory can be collectively recalled and consecutively played back as a movie. Such a movie held in frame memory is called a “frame memory clip.”

## Recording time of a clip

The recording time of a clip varies depending on the video formats as follows.

Video format	Recording time
480i/59.94	94
576i/50	96
1080i/50	20
1080i/59.94	17
1080PsF/23.976	21
1080PsF/24	21
1080PsF/25	20
1080PsF/29.97	17
720P/50 <sup>a)</sup>	23
720P/59.94 <sup>a)</sup>	19

a) In 720P format, movies are recorded in units of one frame.

## How many clips can be stored

You can store up to fifty pair clips (a hundred single clips) in frame memory. If you attempt to store more than those clips, an error message appears.

## Single clips and pair clips

There are two kinds of clips as follows.

**Single clip:** A clip which includes one signal component. This clip is only available in single mode.

**Pair clip:** A clip which includes a pair of two signal components (video and key signals). This clip is available both in single mode and pair mode.

## Single mode and pair mode

Frame memory clip operations are performed in one of the following modes.

**Single mode:** An operation mode where video and key signals are handled separately.

**Pair mode:** An operation mode where video and key signals are handled collectively.

## Clip Creation

You save a movie as a clip.

From the top menu, select Frame Memory >Clip Record. The Clip Record menu appears.

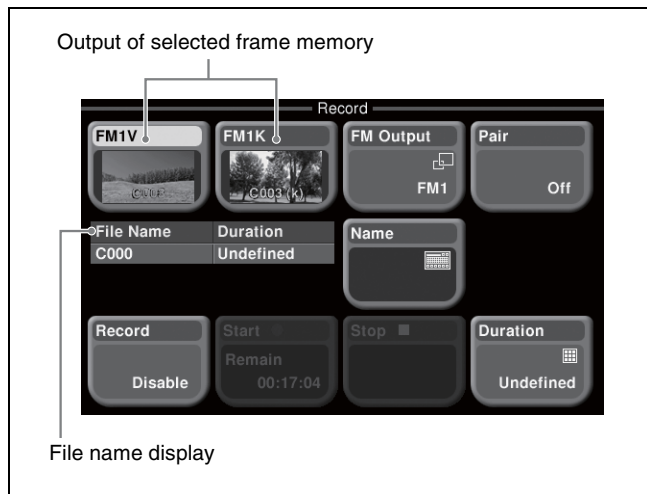

Clip creating operations are the same as in the Animation >Record menu. See “Recording a Series of Images in Frame Memory” (page 141).

## Recalling Clips

You recall a clip stored in frame memory.

1 From the top menu, select Frame Memory >Recall.

The Recall menu appears.



2 If necessary, press [FM Output] to change the output destination of the frame memory. (In the above figure [FM1] is selected.)

3 When [Clip View] is Off, press the button, turning it On.

4 To handle video signal and key signal as a pair (pair mode), press [Pair], turning it On.

In single mode (when [Pair] is Off), press the video signal button ([FM1V] in the above figure) or the key signal button ([FM1K] in the above figure) to select the target.

The selected button turns light blue.

**5** From the file list, select the desired clip using one of the following procedures.

- Press directly on the list appearing in the status area.
- Press the arrow buttons to select from the list.
- Use the knobs or buttons.

Knob/button	Description	Setting values
1 (No)	File number	1 to number of saved image files
2 (Number)	Number of files to select consecutively from selected file	—
3 (Back)	Jump to the previous file. <sup>a)</sup>	—
4 (Fwd)	Jump to the next file. <sup>a)</sup>	—

a) The files whose names are indented are skipped.

The selected clip images are displayed on the right of the status area.

**6** Press [Recall].

The selected clip is recalled and its images are displayed on the [FM1V] and [FM1K] buttons.

## Clip Playback

You play a recalled clip.

**1** From the top menu, select Frame Memory >Clip Play.

The Clip Play menu appears.

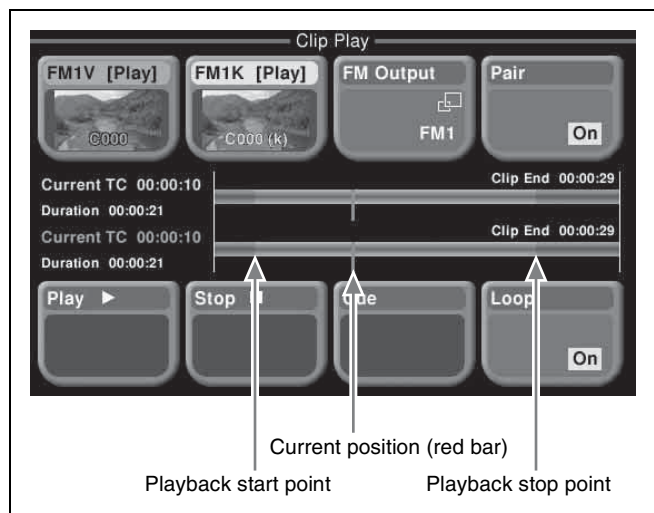

**2** If necessary, press [FM Output] to change the output destination of the frame memory. (In the above figure [FM1] is selected.)

**3** In single mode, press the video signal button or the key signal button to select the target.

The selected button turns light blue.

**4** To play the clip, press [Play].

**5** To stop the clip, press [Stop].

### To specify the playback start point and the playback stop point

Turn the knobs to adjust the parameters.

Knob	Description	Setting values
1 (Start TC)	Setting playback start point	00:00:00 to upwards
2 (Start TC CLR)	Setting playback start point to 00:00:00	
3 (Stop TC)	Setting playback stop point	00:00:00 to upwards
4 (Stop TC CLR)	Setting playback stop point to end of clip	

### Indications of playback

During playback of a frame memory clip, the following “Play” indications are displayed.



### To set loop playback

Press [Loop], turning it On.

### To cue up

Press [Cue].

## Using Utility Control Block for Clip Operations

### Note

To carry out the following operations, it is necessary to have assigned the appropriate commands to the buttons of the utility control block.

For how to assign the commands, see “Assigning utility commands” (page 218).

**1** Press one of the following buttons to select the target clip.

- [FM1 Clip] to [FM3 Clip]
- [FM1V Clip] to [FM3V Clip]
- [FM1K Clip] to [FM3K Clip]

For details of the buttons, see “Utility Control Block” (page 24).

**2** For the selected clip, use the following buttons to carry out the operations.

**JOG:** Makes frame advances in the forward or reverse direction.

**SHTL:** Varies playback speed to a maximum of 50 times normal in the forward or reverse direction.

**STOP:** Stops playback.

**PLAY:** Starts playback.

**CUE:** Cues up.

**ALL STOP:** Stops all devices to be controlled.

**FM LOOP:** Turns on and off loop playback.

**START TC:** Sets playback start point.

**STOP TC:** Sets playback stop point.

In the Flexi Pad control block, the same operations can be carried out as in the utility control block.

# Image File Operations

## Renaming a image file

It is possible to turn multiple still image files into one clip by renaming them collectively.

**1** From the top menu, select Frame Memory >File >Rename.

The Rename menu appears.

Regardless of whether pair mode is on or off, all the still image files saved in frame memory appear in the list.

To display only clips, press [Clip View], turning it on.

For details, see “Switching list items between still image files and clips” (page 148).

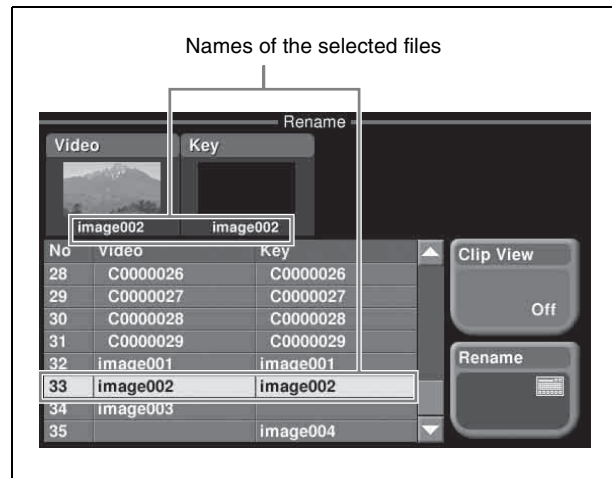

**2** Select the file to operate on.

- Press directly on the list appearing in the status area.
- Press the arrow buttons to select from the list.
- Use the knobs or buttons.

Knob/button	Description	Setting values
1 (No)	File number	1 to number of saved image files
2 (Number)	Number of files to select consecutively from selected file	—
3 (Back)	Jump to the previous file. <sup>a)</sup>	—
4 (Fwd)	Jump to the next file. <sup>a)</sup>	—

<sup>a)</sup> The files whose names are indented are skipped.

When [Clip View] is Off, you can select multiple still image files with the knob 2.

For Pair files, the video and key files are selected together.

It is not possible to select either individually.

### 3 Press [Rename].

A keyboard window appears.

See “Keyboard window” (page 40) in Chapter 3 for more information about keyboard window operations.

### 4 Enter the new name, and press [Enter].

When you select multiple still image files, enter a clip name (up to four characters). A four-digit number is automatically appended to the name making the files available as a clip.

#### Note

The following names cannot be used:

CON, PRN, AUX, CLOCK\$, NUL, COM0, COM1, COM2, COM3, COM4, COM5, COM6, COM7, COM8, COM9  
LPT0, LPT1, LPT2, LPT3, LPT4, LPT5, LPT6, LPT7, LPT8, LPT9

This renames the selected file.

## Deleting an image file

### 1 From the top menu, select Frame Memory >File >Delete.

The Delete menu appears.

Regardless of whether pair mode is on or off, all the files saved in frame memory appear in the list.

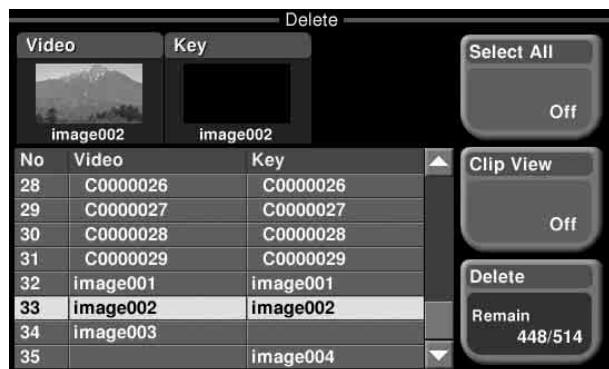

### 2 Select the file to be deleted.

- Press directly on the list appearing in the status area.
- Press the arrow buttons to select from the list.
- Use the knobs or buttons.

Knob/button	Description	Setting values
1 (No)	File number	1 to number of saved image files
2 (Number)	Number of files to select consecutively from selected file	–
3 (Back)	Jump to the previous file. <sup>a)</sup>	–
4 (Fwd)	Jump to the next file. <sup>a)</sup>	–

a) The files whose names are indented are skipped.

To select all files, press [Select All], turning it on.

### 3 Press [Delete].

A message appears, asking for confirmation of the deletion.

### 4 To carry out the deletion press [Yes], and to cancel press [No].

If you press [Yes], this deletes the file or files. The number of files that can be saved shown on the [Delete] button increases by the number of files deleted.

If you press [No], the system returns to the state before step 2.

## Creating a pair file from two single files

### 1 From the top menu, select Frame Memory >File >Couple.

The Couple menu appears.



### 2 From the file list, select the single file to be assigned to video.

- Press directly on the list appearing in the status area.
- Press the arrow buttons to select from the list.
- Use the knobs or buttons.

Knob	Description	Setting values
1 (No)	File number	1 to number of saved image files
2 (Video/Key)	Switch the selection of rows (Video/Key).	—
3 (Back)	Jump to the previous file. <sup>a)</sup>	—
4 (Fwd)	Jump to the next file. <sup>a)</sup>	—

a) The files whose names are indented are skipped.

### 3 Press [Video Select].

A checkmark (  ) appears in front of the selected file.

### 4 If necessary, turn knob 2 (Video/Key) to toggle the selected cell between Video and Key columns.

### 5 Select the single file to be assigned to key in the same way as in step 2.

### 6 Press [Key Select].

A checkmark (  ) appears in front of the selected file.

### 7 Press [Couple].

A confirmation message appears

### 8 Press [Yes].

This makes a pair file from the selected files.  
The pair file is named after the name of the video files.

## Splitting a pair file into two single files

### 1 From the top menu, select Frame Memory >File >Separate.

The Separate menu appears.



### 2 From the file list, select the desired pair of the files.

- Press directly on the list appearing in the status area.
- Press the arrow buttons to select from the list.
- Use the knobs or buttons.

Knob/button	Description	Setting values
1 (No)	File number	1 to number of saved image files
2 (Number)	Number of files to select consecutively from selected file	—
3 (Back)	Jump to the previous file. <sup>a)</sup>	—
4 (Fwd)	Jump to the next file. <sup>a)</sup>	—

a) The files whose names are indented are skipped.

### 3 Press [Separate].

A keyboard window appears.

### 4 Enter the name of the key single file and press [Enter].

The selected file is split into separate single files and key is saved as video. By default a still image file is given the name “spxxx” (“xxx” is a three-digit number from 001 to 999) and a clip file is given the name “spxx” (“xx” is a two-digit number from 01 to 99).

## Switching list items between still image files and clips

[Clip View] button switches the list items as follows.

**Off:** All the still image files, including the clip component files whose names are indented below their clip names, are displayed.

**On:** Only clips are displayed.

### When [Clip View] is Off.

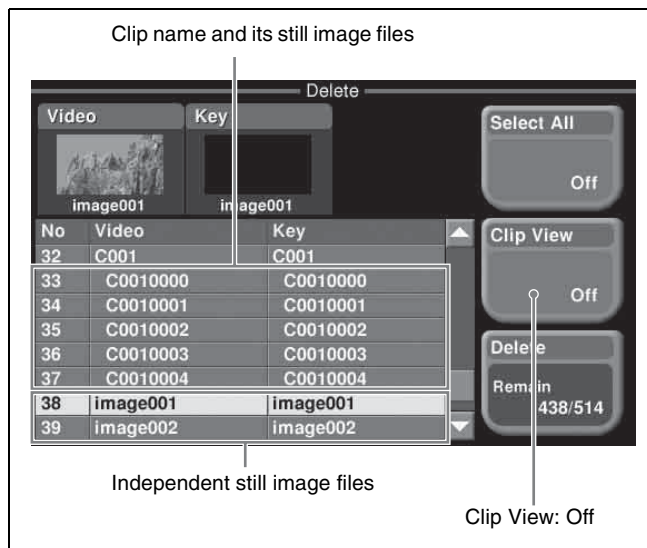

## When [Clip View] is On.

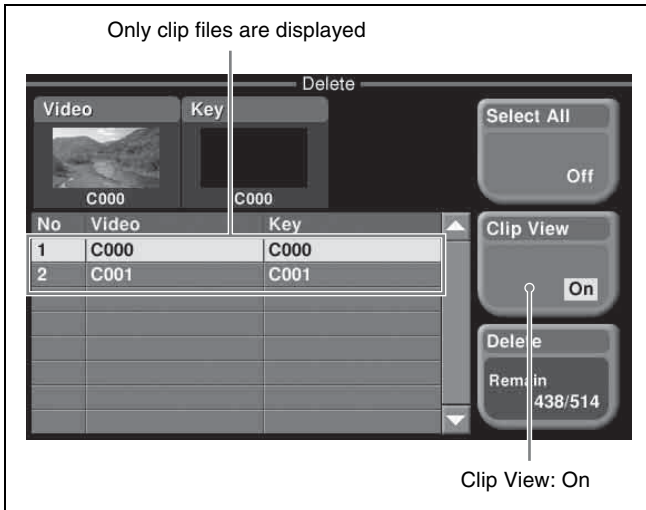

### Note

When [Clip View] is Off, clip names can not be selected.

# Clip Transition

Linked to a mix or wipe transition, a frame memory clip (movie) is played back.

## Setting a clip transition

The following example describes the case of a clip transition using FM 1 Clip on the M/E-1 bank.

### Note

To use a clip transition effectively, the image from the frame memory clip being played back during the clip transition should be seen in the M/E program output. Therefore, some operations, such as inserting a key using frame memory output 1, are needed before the following procedure.

- 1 From the top menu, select Misc >Transition >M/E Type.

When a popup window appears, select FM1 Clip.

- 2 From the top menu, select Misc >Clip Transition >M/E Clip Trans.

The M/E Clip Transition menu appears.

- When [FM1 Clip] is selected with background/clip selection buttons, the following screen appears.

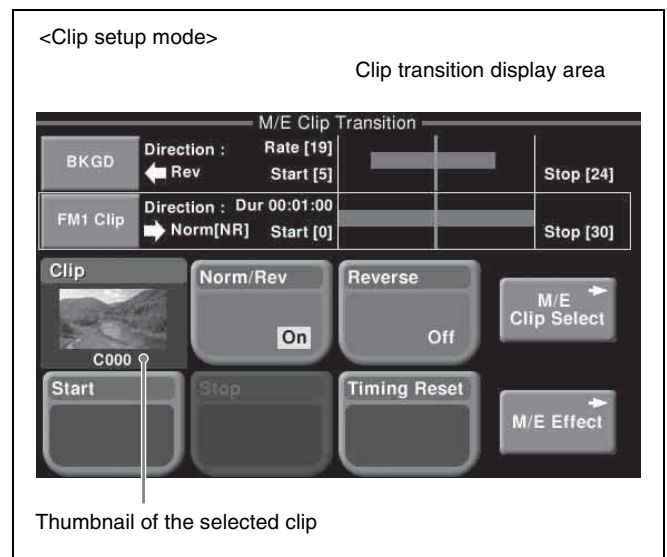

- When [BKGD] is selected with background/clip selection buttons, the following screen appears.

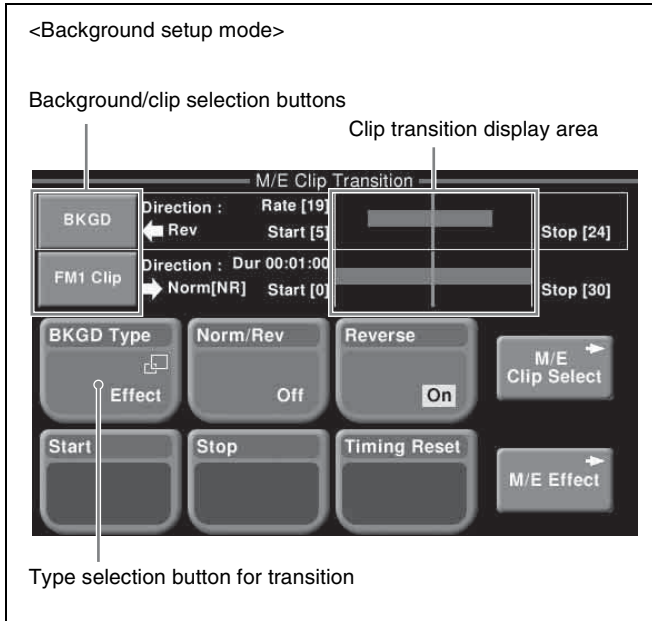

**3** In clip setup mode, press [M/E Clip Select].

The M/E Clip Select menu appears, and the status area shows a list of clips.

**4** Select the clip to use in the clip transition.

**5** In background setup mode, press [BKGD].

A popup window appears.

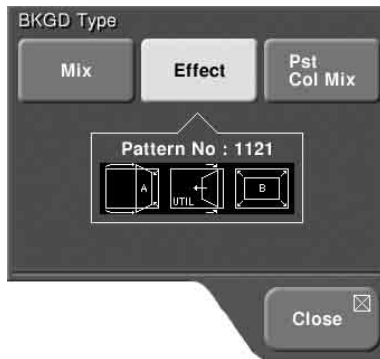

**6** Select the background transition type.

**Note**

For details of the background transition selected here, make proper adjustments with the Misc >Transition and other menus.

**7** Use either of the following methods to set the start point of the background.

- Move the fader lever to the desired position, and press [Start].
- Turn the knob to set the number of frames. (For the position of frame 0, see the following figure.)

Knob	Description	Setting values
3 (Start)	Transition start point	0 to 999

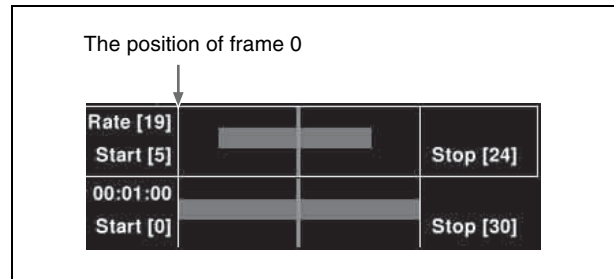

**8** Use either of the following methods to set the end point of the background transition.

- Move the fader lever to the desired position, and press [Stop].
- Turn the knob to set the number of frames.

Knob	Description	Setting values
4 (Stop)	Transition end point	0 to 999

**9** Switch to clip setup mode, and set the start point of the clip using one of the following methods.

- Move the fader lever to the desired position, and press [Start].
- Turn the knob to set the number of frames. (For the position of frame 0, see the previous figure.)

Knob	Description	Setting values
3 (Start)	Transition start point	0 to 999

**Note**

It is not possible to set the end point for a clip.

**To reset the start points and end point**

Press [Timing Reset].

The start point and end point of the background transition and the start point of the clip are reset all at once.

**To switch the background transition direction between normal and reverse alternatively**

When effect is selected as the transition type, to alternate the background transition directions press [Norm/Rev], turning it on.

**To reverse the direction of transition or playback**

Press [Reverse], turning it on.

**Notes on using clip transitions**

The following restrictions apply to the use of a clip transition.

- Key frame capture is not possible.
- It is not possible to apply a pattern limit.

- Transitions executed in two strokes, such as a preset color mix with the stroke mode set to Normal, or a DME wipe with a picture-in-picture pattern, will not execute correctly.
- It is not possible to vary the transition rate of a clip transition.
- While executing a clip transition, you can not save any midway image as a snapshot.

## External Hard Disk Drive Access

You can connect a hard disk drive to the MFS-2000 system, and save and recall image data from frame memory.

Since image data saved in memory is lost when the system is powered off, using an external hard disk drive allows required data to be preserved.

### Notes

- Only one hard disk drive can be connected to each system.
- While the hard disk is being accessed, frame memory operations are not possible from the control panel. All the frame memory operations, including recalling frame memory image data by a snapshot, are out of control.

*Consult a Sony service representative or sales representative about the hard disk drives that can be connected.*

## Hard Disk Formatting

When you connect a hard disk drive for the first time, it is necessary to format the hard disk. This partitions the disk, creating five logical drives (FMHDD1 to FMHDD5).

- 1 From the top menu, select Frame Memory >External HDD >Format.

The Format menu appears.

- 2 Press [Refresh].

The product information for the connected hard disk drive appears at the upper right of the screen.

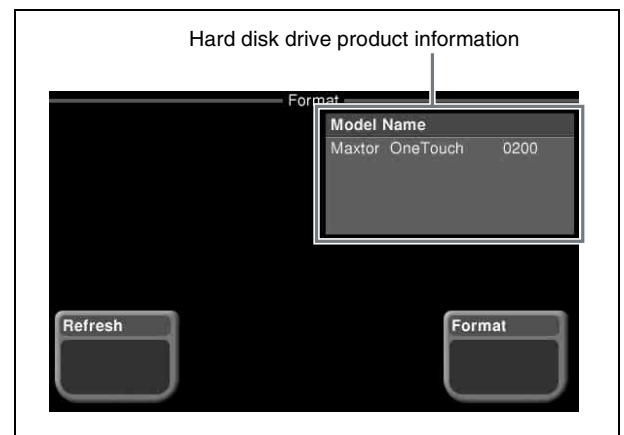

- 3 Press [Format].

A popup window for confirming formatting appears.

**Note**

Carrying out formatting erases any existing data on the hard disk.

4 Press [Yes].

This starts the hard disk formatting, and a window appears, showing the progress of the operation. When the operation is completed successfully, a completion message appears.

Press [OK] to close the window.

## Saving frame memory files to the External Hard Disk

You can save all of the files from frame memory to the external hard disk drive.

**Note**

Before carrying out this operation for the first time, it is necessary to format the hard disk. (See *previous item*.)

1 From the top menu, select Frame Memory >External HDD >Backup/Restore.

The Backup/Restore menu appears.

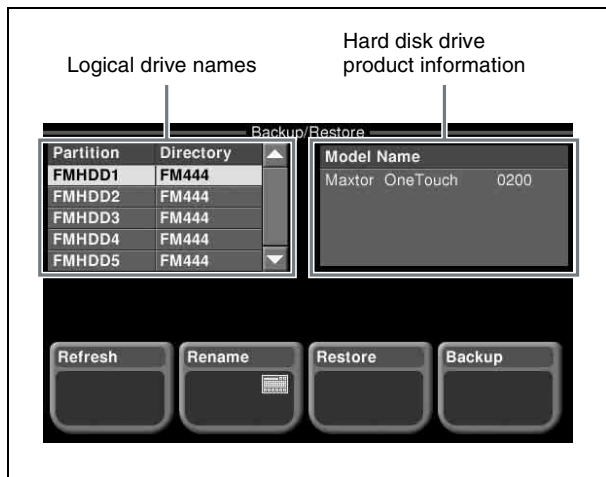
**To get the hard disk drive information**

Press [Refresh].

The product information for the connected hard disk drive appears at the upper right of the screen.

2 Using any of the following methods, select a logical drive (FMHDD1 to FMHDD5).

- Press directly on the list in the status area.
- Use the arrow buttons to scroll the reverse video cursor.
- Turn the knob.

Knob	Description	Setting values
1 (Partition)	Logical drive selection	1 to 5

3 Press [Backup].

A popup window for confirming file saving appears.

**Note**

When you save the files, all of the saved files in the logical drive are erased immediately before the saving operations.

4 Press [Yes].

This starts the file saving operation. If there is no directory in the logical drive, a directory is automatically created, and the files are saved within it. A window appears, showing the progress of the operation.

When the operation is completed successfully, a completion message appears.

Press [OK] to close the window.

## Renaming a directory

1 In the Frame Memory >External HDD >Backup/Restore menu, select the directory you want to rename from the list.

2 Press [Rename].

A keyboard window appears.

3 Enter the new directory name (maximum eight characters), and press [Enter].

This renames the directory.

**Note**

The following names cannot be used:

CON, PRN, AUX, CLOCK\$, NUL, COM0, COM1, COM2, COM3, COM4, COM5, COM6, COM7, COM8, COM9  
LPT0, LPT1, LPT2, LPT3, LPT4, LPT5, LPT6, LPT7, LPT8, LPT9

## Recalling Files From the External Hard Disk

You can recall all of the saved files on the hard disk drive into frame memory.

1 Carry out steps 1 and 2 of the procedure “Saving frame memory files to the External Hard Disk” (page 152).

**Note**

It is not possible to select a directory (logical drive) on which files are not saved.

2 Press [Restore].

A popup window for confirming file recall appears.

**Note**

When you recall the files, any existing data in frame memory is lost immediately before the recalling operation.

3 Press [Yes].

This starts the file recalling operation. A window appears, showing the progress of the operation. When the operation is completed successfully, a completion message appears.

Press [OK] to close the window.

# Snapshots

## Overview

The term “snapshot” refers to a function whereby the various settings required to apply a particular effect to an image are saved in memory as a set of data, for recall as required, to recover the original state.

Snapshot operations use the Flexi Pad control block.

## Snapshot types

There are two types of snapshot: those called simply “snapshot”, and effect snapshots. They differ in the types of data saved and the save destination registers (memory locations for saving data).

## Snapshots

These are sets of data saved for each region (functional unit block) to enable recall of video states.

### Snapshot target data and number of registers

Target data	Number of registers (register numbers)
M/E region data	99 (1 to 99)
PGM/PST region data	99 (1 to 99)
Following data included in Misc regions <sup>a)</sup> <ul style="list-style-type: none"> <li>• Color background</li> <li>• AUX 1 to 4</li> <li>• CCR1, CCR2</li> <li>• Frame memory</li> </ul>	99 (1 to 99)

a) Use the Setup/Diag >Operation >Snapshot/Timeline menu (page 225) to specify whether or not to include in Misc.

**Note**

In this version, PGM/PST and Misc data cannot be saved and recalled individually.

## Effect snapshots

These are sets of data saved to enable recall of M/E effect settings and PGM/PST wipe settings.

### Effect snapshot target data and number of registers

Target data	Number of registers (register numbers)
Effect pattern numbers and modifiers set on M/E bank	10 (1 to 10)
Effect (wipe) pattern numbers and modifiers set on PGM/PST bank	10 (1 to 10)

## Snapshot attributes

An individual snapshot may also have attached special conditions relating to switcher operation when the snapshot is recalled.

These conditions are called “attributes” of the snapshot, and can be added when the snapshot is saved or recalled. There are four snapshot attributes, as follows.

**Cross-point hold:** When the snapshot is recalled, the cross-point button selection remains unchanged. <sup>1)</sup>

The same setting is used for both A and B buses. Also, the same setting is used for both PGM and PST buses.

**Key disable:** When the snapshot is recalled, the key settings (including key on/off states, if specified by setup settings) remain unchanged. <sup>1)</sup> This can be set independently for each keyer.

**Effect dissolve:** The transition from the state before the snapshot recall to the snapshot settings is carried out smoothly, by a dissolve.

**Auto transition:** An auto transition starts the instant the snapshot is recalled. The auto transition setting is valid for M/E and PGM/PST.

**Clip event:** A frame memory clip is recalled the instant the snapshot is recalled. And, if [Auto Play] has been set to on, a frame memory clip starts playback the instant the snapshot is recalled.

<sup>1)</sup> There are three hold modes for key buses: Xpt Hold, Key Disable, and Key Disable with Status. Select one of the modes with the Setup/Diag >Operation >Key menu. See page 222.

## Usable attributes

The following table shows the attributes which can be used in each region.

Yes: Usable No: Not usable

Attribute	Region		
	M/E	PGM/PST	Misc
Cross-point hold	Yes	Yes	Yes
Key disable	Yes	Yes	No
Effect dissolve	Yes	Yes	Yes
Auto transition	Yes	Yes	No
Clip event	No	No	Yes

## Attribute display

You can view the attributes of a snapshot in the Register >Snapshot >Attribute menu.

## Temporary attributes

When recalling a snapshot, you can temporarily apply attributes distinct from the attributes set for each register. These are called “temporary attributes”.

## Bus override

Even when the setting of the temporary attribute “cross-point hold” is off, you can recall a snapshot while maintaining the current cross-point selection. This function is called “bus override”.

On how to use the bus override function, see page 156.

## Saving Snapshots

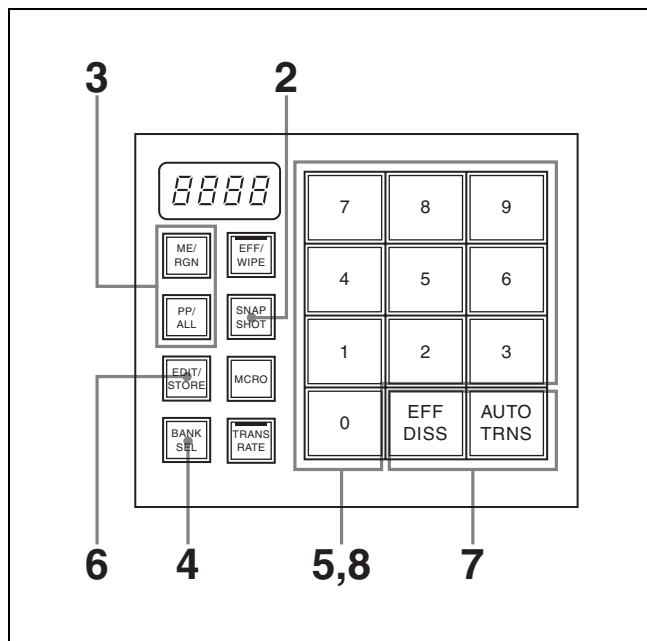

**1** Set up the state that you want to save as a snapshot.

**2** Press the [SNAPSHOT] button, turning it on.

The Flexi Pad control block enters snapshot operation mode.

**3** Press and light the region selection button for the region which you want to save.

[ME/RGN] button: Selects the M/E region.

[PP/ALL] button: Selects all regions.

**4** Press the [BANK SEL] button, turning it on.

The display on the memory recall buttons changes to the state shown in the above figure. You can now select the save destination bank.

Banks are the 99 registers divided into 10 groups. The following table shows the correspondences bank numbers and register numbers.

Bank number	Register number
Bank 0	1 to 10
Bank 1	11 to 20
Bank 2	21 to 30
Bank 3	31 to 40
Bank 4	41 to 50
Bank 5	51 to 60
Bank 6	61 to 70
Bank 7	71 to 80

Bank number	Register number
Bank 8	81 to 90
Bank 9	91 to 99

**5** Press a memory recall button to select a bank.

The most significant digit in the numeric display shows the number of the selected bank. This is also indicated by the display on the memory recall buttons. For example, the display is as shown below when bank 3 is selected.

37	38	39
34	35	36
31	32	33
40	EFF DISS	AUTO TRNS

**6** Press the [EDIT/STORE] button, turning it on.

The snapshot can now be saved.

**7** To add attributes, press the following buttons to put them into the selected state.

Attribute to add	Button pressed
Effect dissolve	[EFF DISS] button
Auto transition	[AUTO TRANS] button

**Lit green:** Selected

**Lit orange:** Not selected

**8** Press the memory recall button corresponding to register in which you want to save the snapshot.

**Note**

The contents of the corresponding register are overwritten if you press a button which is lit in orange or yellow.

The pressed button lights in yellow when the saving of the snapshot is finished.

The numeric display shows the selected bank number, followed by the register number.

For example, if you selected register 37, the display shows “3-37”.

## Recalling Snapshots

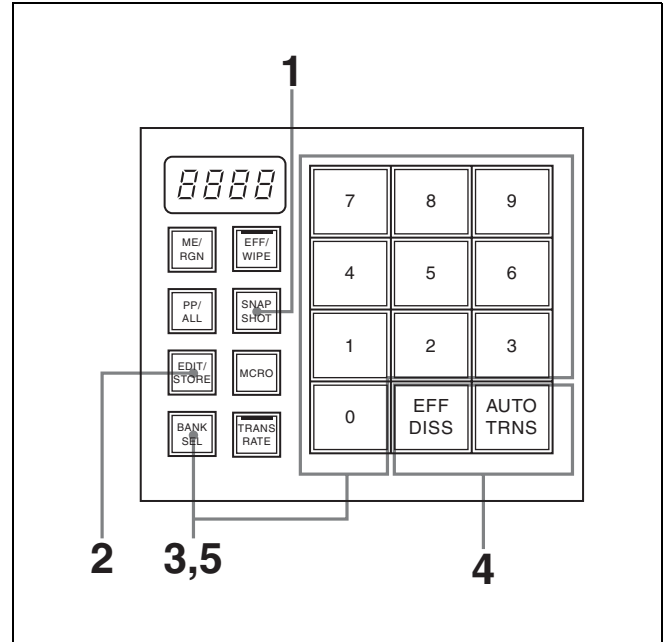

**1** Press the [SNAPSHOT] button, turning it on.

The button lights in amber, and the Flexi Pad control block enter snapshot operation mode.

Also, the numeric display shows the number of the bank selected last time, and the number of the register most recently recalled for the region.

**2** If the [EDIT/STORE] button is lit, press the button, turning it off.

**3** Select the bank to recall.

*See steps 4 and 5 of “Saving Snapshots” (page 154).*

**4** If you want to use a temporary attribute (see page 154), press one of the following buttons, selecting and lighting it.

**M/E and PGM/PST cross-point control blocks, AUX bus control block**

Temporary attribute	Button pressed
Cross-point hold	[XPT HOLD] button in M/E and PGM/PST cross-point control blocks
Cross-point hold or key disable for key bus	[XP/KY HOLD] button in AUX bus control block
Cross-point hold for Aux bus	

**Flexi Pad control block**

Temporary attribute	Button pressed
Effect dissolve	[EFF DISS] button

### Flexi Pad control block

Temporary attribute	Button pressed
Auto transition	[AUTO TRNS] button

**Lit in green:** Selected

**Lit in orange:** Not selected

See page 154 for the attributes which may be used.

#### Note

The Cross-point hold and Key disable states last until the [XPT HOLD] or [XP/KY HOLD] button is pressed again.

- 5 Press the memory recall button for the register where the snapshot that you want is saved (the button is lit in orange).

When the recall is complete, the pressed button lights in yellow.

The numeric display shows the bank number followed by the selected register number.

### To maintain cross-point states temporarily with the bus override function

Recall the snapshot while holding down a cross-point button in the A or B row on the M/E bank or a cross-point button in the PGM or PST row on the PGM/PST bank. The snapshot is recalled without changing the selection of the signal on the bus. This operation is not necessary when cross-point hold is on.

## Deleting Snapshots

- 1 In the Flexi Pad control block, press the [EDIT/STORE] button, turning it on.
- 2 While holding down the [SNAPSHOT] button, press the memory recall button for the snapshot that you want to delete.

The button goes out after the snapshot is deleted.

## Editing Snapshot Registers

You can edit snapshot registers in the following ways.

**Rename:** Change the name of the snapshot register.

**Lock:** Prevent register editing operations (overwriting and deleting of data in the register, renaming of the register, and changing of attributes).

**Delete:** Delete the data in the register.

## Renaming snapshot registers

- 1 From the top menu, select Register >Snapshot >Edit. The Edit menu appears.
- 2 Select a region in the status area. You can select several regions.

#### Note

Regions without register data cannot be selected.

- 3 Do one of the following to select the register.
  - Press directly on the list appearing in the status area.
  - Use the arrow buttons to scroll the reverse video cursor.
  - Turn the knob 1.

Knob	Description	Setting values
1 (Reg No)	Register number	1 to 99

The selected register appears in reverse video.

- 4 Press [Rename].

The keyboard window appears.

See “Keyboard window” (page 40) in Chapter 3 for more information about keyboard window operations.

#### Note

If you pressed [Select All], turning it on, or if you selected several registers, the register with the lowest number in the selected range is the target of the operation.

- 5 Enter a name of up to eight characters, and then press [Enter].

The specified name appears in the list.

#### Note

The following names cannot be used:  
CON, PRN, AUX, CLOCK\$, NUL, COM0, COM1, COM2, COM3, COM4, COM5, COM6, COM7, COM8, COM9  
LPT0, LPT1, LPT2, LPT3, LPT4, LPT5, LPT6, LPT7, LPT8, LPT9

## Disabling editing of snapshot registers (locking the registers)

- 1 Select a region in the status area of the Edit menu. You can select several regions.

**Note**

Regions without register data cannot be selected.

**2** Do one of the following to select the register.

- Press directly on the list appearing in the status area.
- Use the arrow buttons to scroll the reverse video cursor.
- Turn the knobs.

Knob	Description	Setting values
1 (Reg No)	Register number	1 to 99
2 (Number)	Number of registers	1 to 99

- To select all registers, press [Select All], turning it on.

The selected register appears in reverse video.

**3** Press [Lock], turning it on.

**To unlock the register**

Select the register to unlock, and then press [Lock], turning it off.

**Deleting the data in snapshot registers**

**1** Select a region in the status area of the Edit menu. You can select several regions.

**Note**

Regions without register data cannot be selected.

**2** Do one of the following to select the register.

- Press directly on the list appearing in the status area.
- Use the arrow buttons to scroll the reverse video cursor.
- Turn the knobs.

Knob	Description	Setting values
1 (Reg No)	Register number	1 to 99
2 (Number)	Number of registers	1 to 99

- To select all registers, press [Select All], turning it on.

The selected register appears in reverse video.

**3** Press [Delete].

A message appears asking you to confirm the deletion.

**4** Press [Yes] to execute the deletion, or [No] to cancel it.

If you pressed [Yes], the deletion is executed.

If you pressed [No], you return to the state before step **3**.

**Note**

Data in locked registers cannot be deleted.

**Setting Snapshot Attributes**

You can change the following attribute settings.

- Cross-point hold settings
- Effect dissolve duration
- Auto transition settings
- Temporary attribute effect dissolve settings

**Adding cross-point hold settings**

The effect of cross-point hold settings can also be obtained by key disable settings.

*For setting key disable, see page 222.*

**1** From the top menu, select Register >Snapshot >Attribute.

The Attribute menu appears.

**2** Select a region in the status area.

**Note**

Regions without register data cannot be selected.

**3** Do one of the following to select the registers.

- Press directly on the list in the status area.
- Use the arrow buttons to scroll the reverse video cursor.
- Turn the knobs.

Knob	Description	Setting values
1 (Reg No)	Register number	1 to 99
2 (Number)	Number of registers	1 to 99

- To select all registers, press [Select All], turning it on.

The selected register appears in reverse video.

**4** Press [Xpt Hold].

A popup window appears.

**5** For the following targets, select the cross-points to which you want to add the cross-point holds.

**When the M/E region is selected**

- Bkgd A: Background A bus
- Bkgd B: Background B bus

- Key 1: Key1 bus
- Key 2: Key2 bus
- Utility: Utility bus

#### When the P/P region is selected <sup>1)</sup>

- Bkgd A: Background A bus
- Bkgd B: Background B bus
- DSK 1: DSK1 bus
- DSK 2: DSK2 bus

#### When the DSK region is selected <sup>2)</sup>

- DSK 1: DSK1 bus
- DSK 2: DSK2 bus

#### When the Misc region is selected

- CCR1: CCR1 bus
- CCR2: CCR2 bus
- Aux 1: Aux 1 bus
- Aux 2: Aux 2 bus
- Aux 3: Aux 3 bus
- Aux 4: Aux 4 bus

1) When using the 1.5 M/E panel

2) When using the 1 M/E panel

## Adding effect dissolves

- 1 Select a region in the status area of the Attribute menu.

#### Note

Regions without register data cannot be selected.

- 2 Do one of the following to select the registers.

- Press directly on the list in the status area.
- Use the arrow buttons to scroll the reverse video cursor.
- Turn the knobs.

Knob	Description	Setting values
1 (Reg No)	Register number	1 to 99
2 (Number)	Number of registers	1 to 99

- To select all registers, press [Select All], turning it on.

The selected register appears in reverse video.

- 3 Press [Eff Diss], turning it on.
- 4 Turn knob 4 to set the effect dissolve duration.

Knob	Description	Setting values
4 (Eff Diss)	Effect dissolve duration	0 to 999

The setting change is reflected in all of the selected registers.

## Setting auto transitions

You can set auto transition when the M/E region or P/P region is selected.

- 1 Select a region in the status area.

#### Note

Regions without register data cannot be selected.

- 2 Do one of the following to select the registers.

- Press directly on the list in the status area.
- Use the arrow buttons to scroll the reverse video cursor.
- Turn the knobs.

Knob	Description	Setting values
1 (Reg No)	Number of first register	1 to 99
2 (Number)	Number of registers	1 to 99

- To select all registers, press [Select All], turning it on.

The selected registers are highlighted in reverse video.

- 3 Press [Auto Trans].

The auto transition is set.

## Setting temporary attribute dissolve durations

Turn knob 5 to set the dissolve duration of temporary attributes added with the Flexi Pad control block.

Knob	Description	Setting values
5 (Temp Dur)	Temporary attribute dissolve duration	0 to 999

## Applying the clip event attribute

#### Note

The following operations are applicable only for the frame memory assigned to the Misc region.

- 1 From the top menu, select Register >Snapshot >Clip Event.

The Clip Event menu appears.



- 2 Turn the knob to select a register.
- 3 Press [FM Output] to select the target frame memory output.
- 4 Press [Detail Info] to display the detail information about the current clip and the register.
- 5 To select the current clip, press [Set].
- 6 Press [Clip Event], turning it on.  
The clip event attribute is applied.
- 7 To play the clip as soon as it is recalled, press [Auto Play], turning it on.

# Timeline Function

## Overview

This function allows a sequence of images to be arranged as keyframes on a timeline, to be replayed as a continuous video effect (referred to as a “timeline effect”). By adjusting the time intervals between keyframes and the method of interpolation (referred to as the “path”), a variety of effects can be obtained.

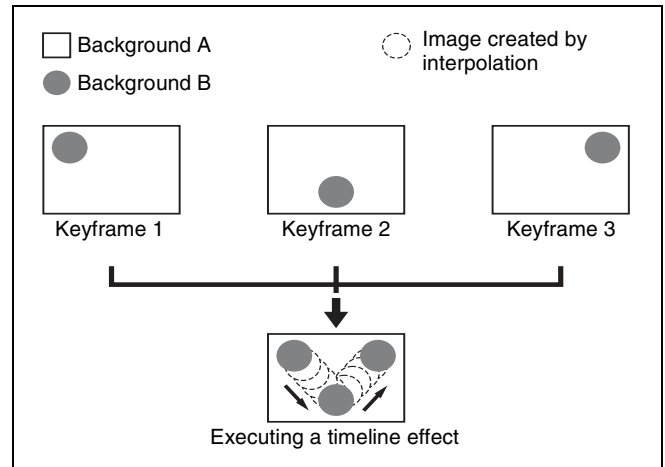

Timeline data is created for each region.

*For details of regions, see “Snapshot target data and number of registers” (page 153).*

## Flow of Timeline Operations

The flow of timeline operations is as follows.

**From timeline data creation to saving**  
 Preparations, including button assignment.

- ↓ Recall the save destination register. (See page 160)
- ↓ Display the Timeline menu. (See page 161)
- ↓ Select the region for operations. (See page 161)
- ↓ Import keyframes. (See page 162)
- ↓ Specify the edit points and editing range. (See page 163)
- ↓ Edit keyframes. (See page 163)
- ↓ Set times on the timeline. (See page 165)
- ↓ Set the path on the timeline. (See page 166)
- ↓ Save the timeline data in the register. (See page 167)

## From recalling the saved timeline data to executing the timeline effect

Recall the timeline data from the register. (See page 167)



Execute the timeline effect. (See page 168)

### Optional operations

- Deleting the timeline. (See page 168)
- Editing timeline registers. (See page 169)

## Preparations for Timeline Operations

### Assigning the timeline operation mode to a button

For timeline operations, you use the control panel Flexi Pad control block and menus.

First assign one of the mode selection buttons in the Flexi Pad control block as a [TIMELINE] button, for changing the mode.

For details of the assignment operation, see “Button Assignments (Button Assign Menu)” (page 225).

### Enabling control of a timeline effect using the fader lever or joystick

To execute a timeline effect, in addition to the buttons in the Flexi Pad, you can use the fader lever or joystick.

- To use the fader lever, assign the transition and timeline operation switching functions to the [PST COLOR MIX] button.

For details of the assignment operation, see “Button Assignments (Button Assign Menu)” (page 225).

- To use the joystick, assign one of the utility control block buttons to the “TL Run Control” command.

For details of assignment operations, see “Utility Settings (Utility Menu)” (page 218).

### Other preparations

You can also make the following settings beforehand.

- Setting the regions included in “Misc”
- Selecting the state of the first keyframe when recalling a timeline effect (whether or not to recover the state)
- Selecting whether to automatically create a first keyframe when recalling an empty register
- Default value of the keyframe duration

For details of the setting operation, see “Snapshot / Timeline Settings (Snapshot / Timeline Menu)” (page 225).

## Recalling the Register in Which You Want to Save the Timeline

There are 99 timeline data registers (1 to 99).

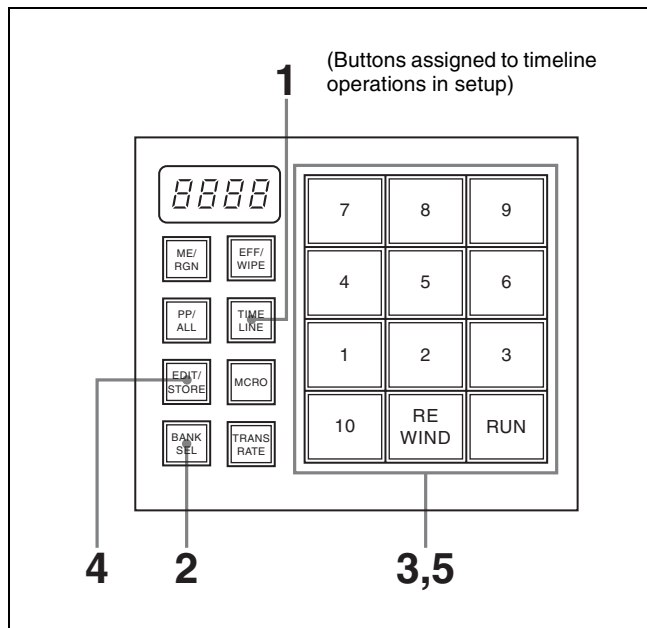

- 1 In the Flexi Pad control block, press the [TIME LINE] button, turning it on.

The [TIMELINE] button lights in amber. The Flexi Pad control block is assigned to timeline recall operation.

- 2 Press the [BANK SEL] button, turning it on.

The memory recall button indications show the bank selection (0 to 9).

For details of the correspondence between banks and registers, see page 154.

- 3 Press a memory recall button to select the bank.

The selected bank number appears in the most significant digit of the numeric display.

The memory recall button shows the register number corresponding to the selected bank, and the register status.

**Lit orange:** Register holding timeline data

**Lit yellow:** Last recalled register

**Off:** Empty register

- 4 Press the [EDIT/STORE] button, turning it on.

- 5 Press the memory recall button showing the number of the register in which you want to save.

This recalls the specified register.

The Flexi Pad control block also switches to editing operation mode, and the [TIMELINE] button lights red.

**Note**

When the [MCRO] button is lit red, it is not possible to put the Flexi Pad control block in timeline edit mode.

## Displaying the Timeline Menu

From the top menu, select Timeline >Timeline. The Timeline menu appears as shown in the following figure.

## Interpreting the Timeline menu

The following items ① to ⑥ are reference region information.

- ① Ref Region: reference region
- ② Delay: delay
- ③ Current TC: current timecode
- ④ Duration: timeline duration
- ⑤ End: sum of timeline duration and delay
- ⑥ Free KF: remaining keyframes

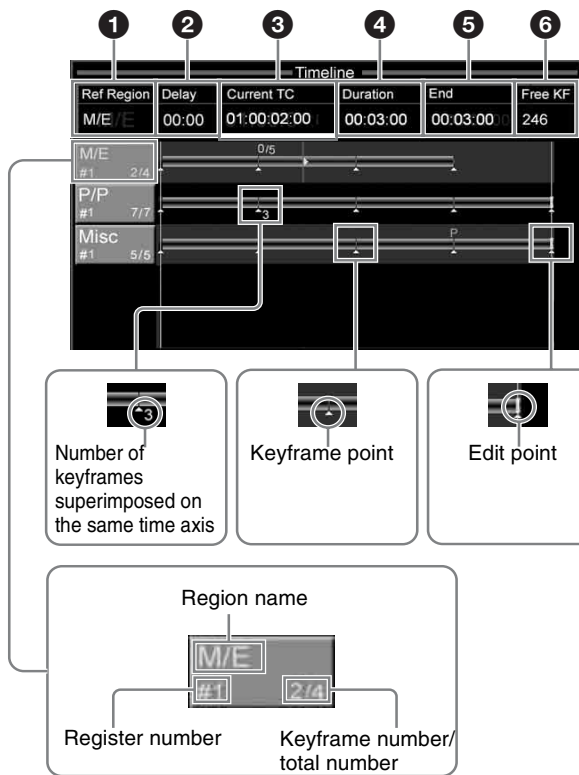

## Switching Menus in Timeline Operations

In menus in the 8000 range, the [Timeline] and [Path] buttons appear.

Press either of these to switch between the Timeline menu and Path menu.

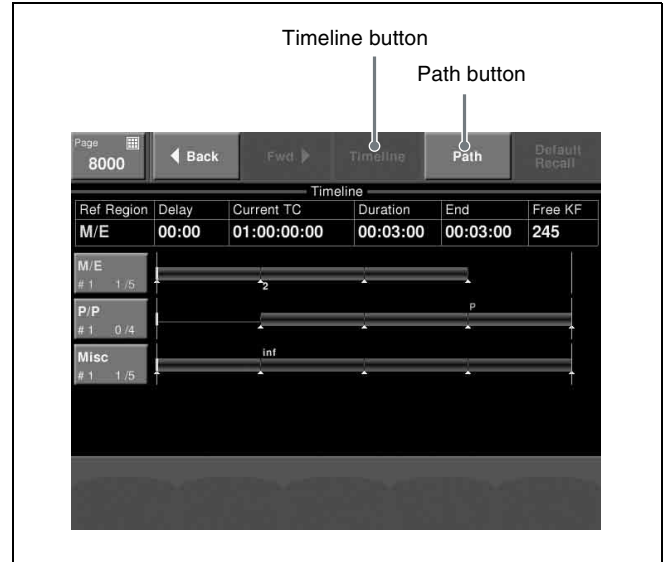

## Selecting the Region for Timeline Editing

When you create or edit timeline data, this applies only to the selected region.

**Note**

When you save or recall a register, and for timeline effect execution, all regions are treated together.

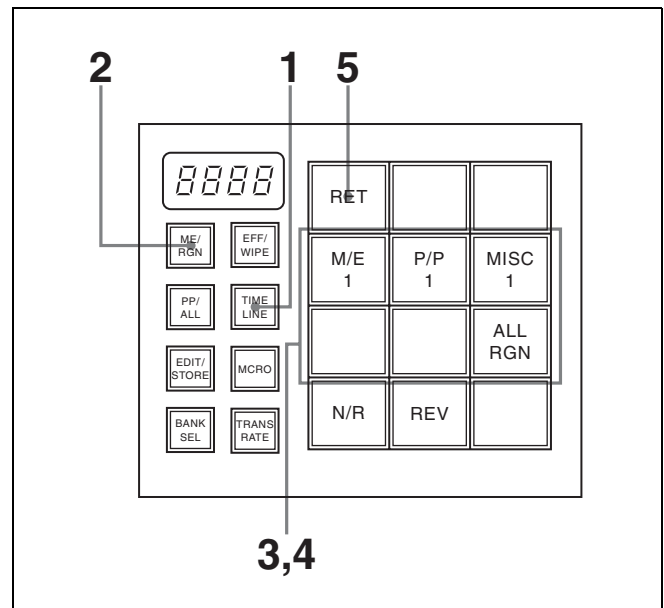

**1** In the Flexi Pad control block, press the [TIMELINE] button, turning it on.

**2** Press the [ME/RGN] button, turning it on.

This assigns the memory recall buttons to region selection.

The M/E, P/P, and MISC buttons indicate the regions. The number under the region name (1 in the figure above) indicates the number of the recalled register.

### Reference region and button lighting colors

The reference region is the single selected region for which the status is shown in menus and on the control panel.

**Lit orange:** Region selected for operation

**Lit green:** Region selected for operation and as the reference region

**Off:** Not selected for operation

- 3 Press the button for the region to be edited, turning it on.  
To select all regions, press the [ALL RGN] button, turning it on.
- 4 To select the reference region, press a button that is already lit orange, turning it green.
- 5 When the selection is complete, press the [RET] button.

The [ME/RGN] button goes off, and the Flexi Pad control block returns to the state in step 1.

- 2 Press the [INS] button.  
This inserts the first keyframe.
- 3 Set the image for the next keyframe, and press the [INS] button once more.
- 4 Repeat step 3 as required to insert all of the keyframes.

This inserts the keyframe images in the sequence entered on the control panel.

The numeric display shows the reference region information as follows.

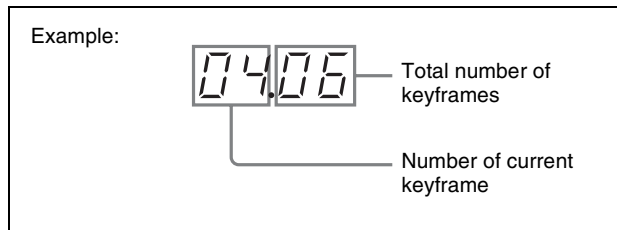

To save without further editing, see “Saving Timeline Data” (page 167).

### To check keyframes

On the timeline during editing operations, you can check the keyframe transitions.

- 1 If necessary, select the region. (See page 161)
- 2 Press the [SHFT] button.

The [SHFT] button lights green, and the memory recall buttons change as shown in the following figure.

## Inserting Keyframes to the Timeline

When you recall a register in which you want to save the timeline, the memory recall buttons in the Flexi Pad control block change as shown in the following figure.

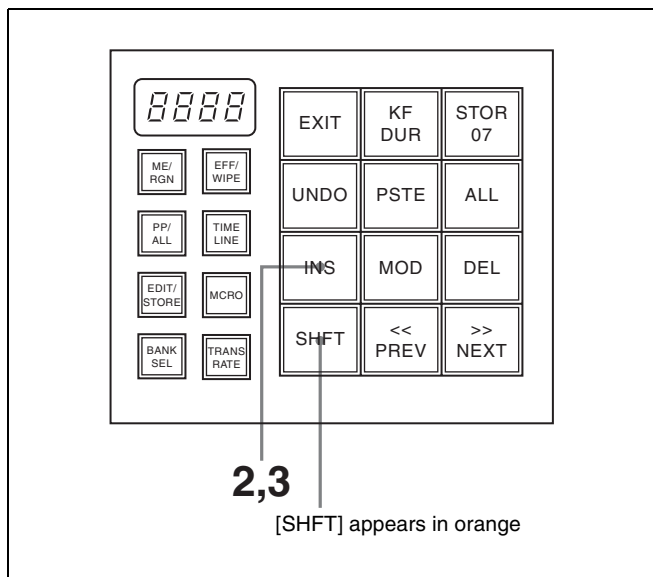

If necessary, select the timeline editing region (see page 161), then proceed as follows.

- 1 Set the image to be used as the first keyframe.

- 3 Press the [REWIND] button.  
This moves to the beginning of the timeline.
- 4 Press the [RUN] button.  
This executes the timeline effect.  
You can also move the fader lever or joystick to check.

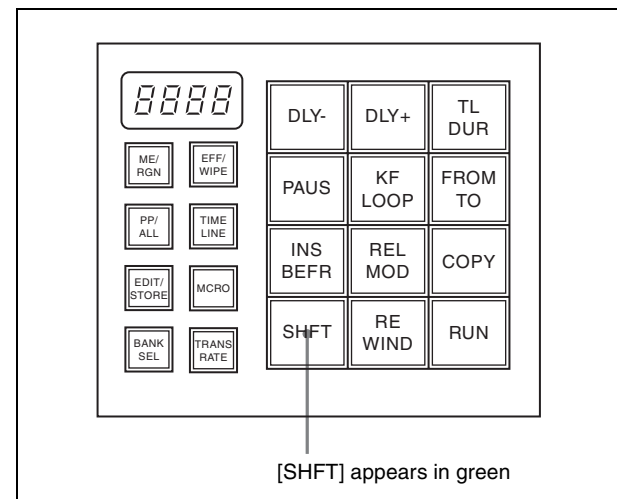

## Specifying Edit Points and Editing Ranges on the Timeline

Before inserting, deleting, or changing keyframes, you specify the keyframe to which the editing operation applies.

If there is no specification, the operation applies to the current position. Except for insertion, when an edit point is between keyframes, the operation applies to the immediately previous keyframe.

### Specifying the previous or next keyframe

To specify the keyframe before the current position, press the [ << PREV ] button in the Flexi Pad control block, and to specify the next keyframe press the [ >> NEXT ] button.

### Specifying any edit points

Move the fader lever or joystick to the position of the keyframe you want to edit.

### Specifying all keyframes in the region

In the Flexi Pad control block, press the [ ALL ] button, turning it on.

For a copy, delete, or modify operation, this selects all keyframes together.

### Specifying a range of keyframes

You can apply copy, delete, and modify operations to a specified range of keyframes together.

- 1 With the Flexi Pad control block [ SHFT ] button lit green (see figure above), press [ FROM TO ].

The “FROM \_\_ TO \_\_” popup window appears in the menu.

A numeric keypad appears in the memory recall section, as shown in the following figure.

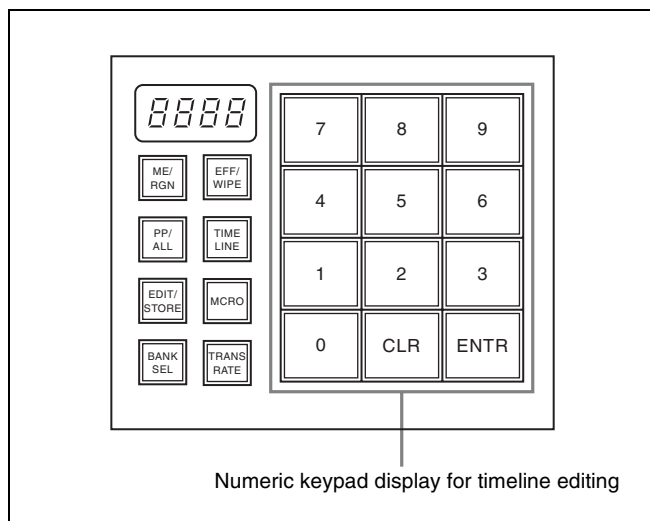

- 2 Enter the keyframe number for the start of the editing range, using the numeric keypad.

The entered value appears after “FROM” in the popup window.

- 3 Enter the keyframe number for the end of the editing range, using the numeric keypad.

The entered value appears after “TO” in the popup window.

- 4 Press the [ ENTR ] button.

This confirms the editing range, and the memory recall buttons return to their previous state. The [ FROM TO ] button lights green.

## Editing Keyframes on the Timeline

Specify the edit point, then carry out the following operations as required.

After editing, be sure to save the timeline data (see page 167).

### Inserting a keyframe

To insert the current state as a new keyframe, in the Flexi Pad control block, press the [ INS ] button.

This inserts the keyframe after the edit point.

### Inserting a keyframe before the edit point

In the Flexi Pad control block, with the [ SHFT ] button lit green (if not lit green, press it) (see page 162), press the [ INS BEFR ] button.

This inserts the keyframe before the edit point.

### Modifying (overwriting) a keyframe

To overwrite with the current state as a new keyframe, in the Flexi Pad control block, press the [ MOD ] button or [ REL MOD ] button.

### Difference in operation between the [ MOD ] button and [ REL MOD ] button

When overwriting multiple keyframes, the [ MOD ] button and [ REL MOD ] button operate differently, as follows. Here, the example is shown in which the circular effect pattern is moved.

## Movement of keyframes 1 to 3 and timeline effect execution before the modification (KF: keyframe)

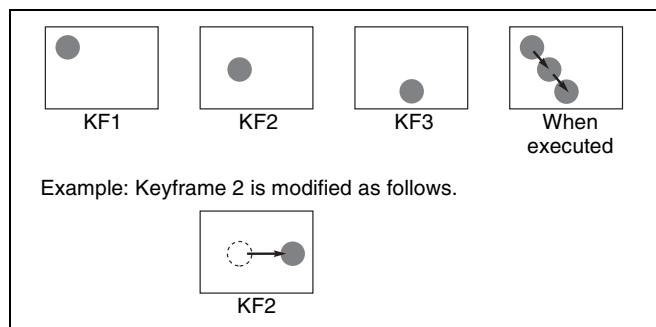

### Modification with the [MOD] button

After carrying out the above modification, if you press the [MOD] button with keyframes 1 to 3 selected, the parameters of keyframes 1 to 3 are all modified as absolute values, and the x-axis position of keyframes 1 to 3 becomes the same as that of keyframe 2.

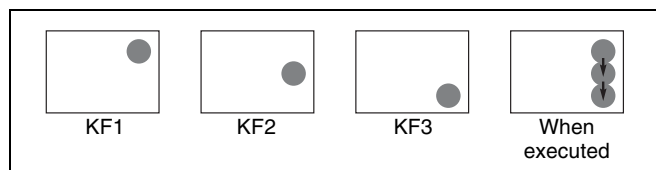

### Modification with [REL MOD] button

After carrying out the above modification, if you press the [REL MOD] button with keyframes 1 to 3 selected, the modified value is added or subtracted as a difference. The effect pattern of keyframes 1 and 3 move to the right by the same amount as keyframe 2.

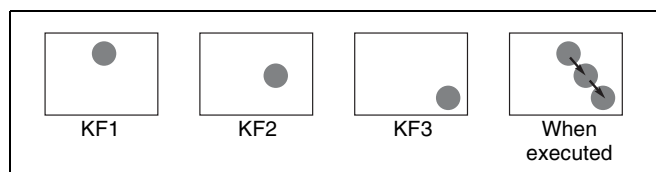

## Deleting a keyframe

Specify the edit point or editing range, then press [DEL] in the Flexi Pad control block.

## Moving a keyframe

- 1 Specify the keyframe you want to move, then press the [DEL] button in the Flexi Pad control block.

This deletes the keyframe.

- 2 Specify the edit point to which you want to move.

- 3 Press the [PSTE] button.

This moves the keyframe deleted in step 1 after keyframe in the specified position.

## Undoing an editing operation

In the Flexi Pad control block, press the [UNDO] button.

## Copying a keyframe

- 1 In the Flexi Pad control block, press the [SHFT] button that is lit orange (*see page 162*).

The [SHFT] button turns green, and the memory recall buttons change.

- 2 Specify the edit point or editing range you want to copy.

- 3 Press the [COPY] button.

- 4 Press the [SHFT] button, returning it to orange.

- 5 Specify the copy destination edit point.

- 6 Press the [PSTE] button.

This copies the current keyframe data.

## Copying multiple keyframes in a single operation

- 1 Specify the range of keyframes you want to copy.

*For details, see “Specifying a range of keyframes” (page 163).*

- 2 Press the [COPY] button.

This makes the specified editing range the copy source.

- 3 Press the [SHFT] button, lighting it orange. (*See page 162.*)

- 4 Specify the edit point for the copy destination.

- 5 Press the [PSTE] button.

This pastes the copy source.

## Setting a pause on a keyframe

If you set a pause, timeline effect execution pauses at that point.

In the Flexi Pad control block, with the [SHFT] button lit green (*see page 162*), press the [PAUS] button.

The [PAUS] button lights green. At the same time, “P” appears in the Timeline menu.

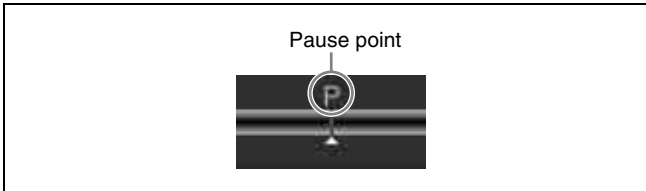

## Setting a keyframe loop

By setting the loop range and loop count, you can execute a section repeatedly.

The loop range can only be set where keyframes exist.

- 1 In the Flexi Pad control block, with the [SHFT] button lit green (see page 162), press the [KF LOOP] button.

A popup window appears in the menu.

The memory recall buttons also change to a numeric keypad.

- 2 Enter the keyframe numbers for the loop start point (STR) and loop end point (END), using the numeric keypad.
- 3 Enter the loop count (CNT), using the numeric keypad.

For an endless loop, enter 0.

- 4 Press the [ENTR] button.

This sets a loop for the specified range.

The [KF LOOP] button lights green, and this appears in the Timeline menu in the following way.

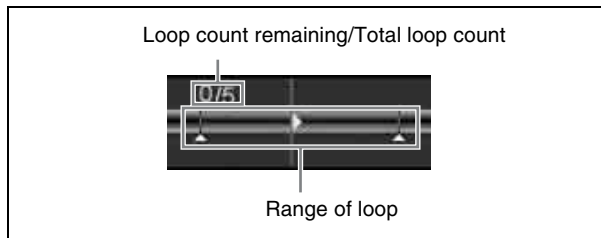

## Setting Times on the Timeline

You can set a keyframe duration, timeline duration, or delay on the timeline.

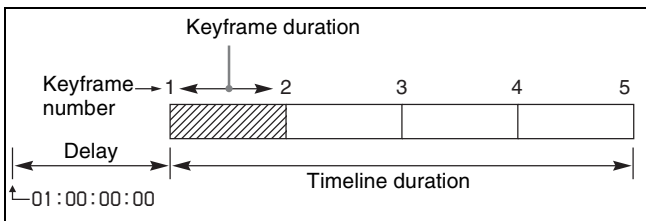

## Setting a keyframe duration

- 1 In the Flexi Pad control block, with the [SHFT] button lit orange (see page 162), press the [KF DUR] button.

A popup window appears in the menu.

The memory recall buttons also change to a numeric keypad.

- 2 Enter the keyframe duration (execution time until the next keyframe) in the format SS:FF (seconds:frames), using the numeric keypad.

- 3 Press the [ENTR] button.

This confirms the keyframe duration.

## Setting the timeline duration

- 1 In the Flexi Pad control block, with the [SHFT] button lit green (see page 162), press the [TL DUR] button.

A popup window appears in the menu.

The memory recall buttons also change to a numeric keypad.

- 2 Enter the timeline duration (total execution time of the timeline) in the format MM:SS:FF (minutes:seconds:frames), using the numeric keypad.

- 3 Press the [ENTR] button.

This confirms the timeline duration.

## Setting a delay on the timeline

When a timeline effect is executed from a rewind operation, it starts at 1:00:00:00.

With 1:00:00:00 as the reference point, you can set an offset (delay) from the position of the first keyframe.

If the delay is set to a negative value, then the timeline effect is set to start from before 1:00:00:00, and therefore starts from a point where time equivalent to the delay value has already elapsed.

- 1 In the Flexi Pad control block, with the [SHFT] button lit green (see page 162), press the [DLY-] button or [DLY+] button.

A popup window appears in the menu.

The memory recall buttons also change to a numeric keypad.

- 2 Enter the delay in the format SS:FF (seconds:frames).

- 3 Press the [ENTR] button.

This confirms the delay setting.

This is shown by a blue line in the Timeline menu.

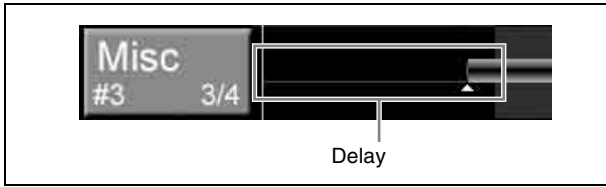

## Setting a Path on the Timeline

Set the way in which the changing image is interpolated between keyframes.

For each region, there are further levels (key 1, key 2, and so on), and you can make a different path setting for each of these.

The path types are as follows.

**Xpt Hold:** Select whether to preserve cross-points.

**Hue:** Select the direction (as seen on a Vectorscope) in which the hue changes.

**Curve:** Set the degree of smoothness of changes.

### Note

After making path settings, always press the [MOD] button in the Flexi Pad control block (see page 162). If you do not press the [MOD] button, the settings will not take effect.

## Displaying the Path menu

From the top menu, select Timeline >Path.

The Path menu appears as shown in the following figure.

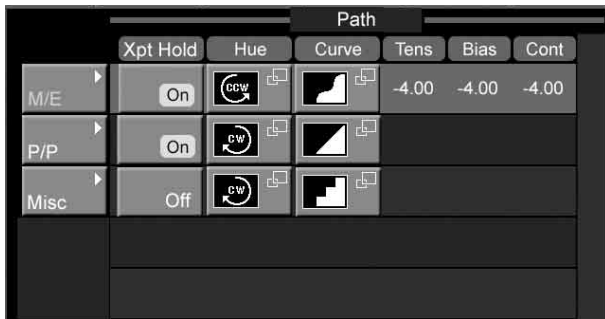

## Changing the Xpt Hold path type

For example, to change the M/E background path settings, proceed as follows.

- In the Timeline >Path menu, press [M/E].  
The lower levels (“Key1” etc.) appear.
- Press the item you want to change (here, “Bkgd/Util”).
- Press the “Xpt Hold” path type indication.  
Each time you press this toggles the setting on and off.

## Setting the Curve path type

For example, to change the M/E Key1 settings, proceed as follows.

- In the Timeline >Path menu, press [M/E].  
The lower levels (“Key1” etc.) appear.
- Press the item you want to change (here, “Key1”).
- In the “Curve” selection, press the path type indication.

A popup window appears.

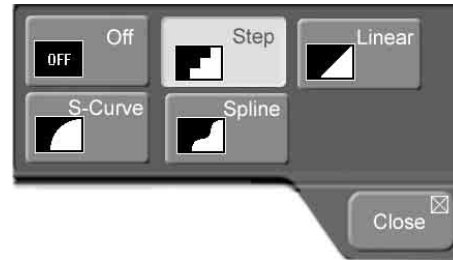

- Press the mark for the path you want to set, to make the selection.

**OFF:** No change as the timeline effect is executed.

**Step:** The parameters change stepwise, being constant between keyframes, and then updating as the effect passes a keyframe.

**Linear:** Linear interpolation between keyframes, providing a constant rate of change.

**S-Curve:** Decelerating and accelerating around each keyframe, so that the rate of change is maximum midway between keyframes.

**Spline:** Use spline curves for smooth interpolation between keyframes.

This changes to the selected path indication.

At this point, the Curve setting affects the Hue and Xpt movements as shown in the following table. The Hue and Xpt settings in the menu do not change, but the path type indication goes dark.

Curve setting	Hue movement	Hold movement
OFF	No change	On
Step	Changes stepwise	Not affected

- If Spline is selected as the path type, set the following parameters with the knobs.

Knob	Setting	Values
2 (Tens)	Tension between keyframes	-4.00 to +4.00
3 (Bias)	Gradient between keyframes	-4.00 to +4.00

Knob	Setting	Values
4 (Cont)	Continuity on keyframes	-4.00 to +4.00

## Changing the Hue path type

For example, to change the M/E effect path, proceed as follows.

- 1 In the Timeline >Path menu press [M/E].  
The lower levels (“Key1” etc.) appear.
- 2 Press the item you want to change (here, “Effect”).
- 3 In the “Hue” selection, press the path type indication.

A popup window appears.



- 4 Press the mark for the path you want to set, to make the selection.

The path type marks show the Hue change as seen on a Vectorscope, as follows.

**CW:** Rotate clockwise.

**CCW:** Rotate counterclockwise.

**Short:** Rotate the hue clockwise or counterclockwise, in the direction giving the shorter path to the next keyframe.

**Long:** Rotate the hue clockwise or counterclockwise, in the direction giving the longer path to the next keyframe.

## Saving Timeline Data

- 1 With the Flexi Pad control block [SHFT] button lit orange (see page 162), press the [STOR XX] button (where “XX” is the current register number).

A popup window appears in the menu. The memory recall buttons change to a numeric keypad.

- 2 To change the current register number, enter the new number. (Omit this operation to use the register number unchanged.)

In the popup window, the register number appears, together with the following characters indicating the register state.

**L:** This register is locked.

**E:** This register is empty.

- 3 Press the [ENTR] button.

This saves the timeline data, and the [EDIT/STORE] button goes off.

The memory recall buttons return to the state before recalling the register (see page 160).

## Exiting the editing operation mode without saving the data

- 1 In the Flexi Pad control block, press the [EXIT] button.
- 2 After recalling a register not being edited, once again recall the register for the editing operation.  
This returns to the state before the editing operation.

## Recalling Timeline Data

- 1 In the Flexi Pad control block, press the [TIMELINE] button, lighting it in amber.

This assigns the Flexi Pad control block to timeline recall operations.

- 2 Press the [BANK SEL] button, turning it on.

*For details of the correspondence between banks and registers, see page 154.*

- 3 Press a memory recall button to select the bank.

The selected bank number appears in the most significant digit of the numeric display.

The memory recall button shows the register number corresponding to the selected bank, and the register status.

**Lit orange:** Register holding timeline data

**Lit yellow:** Last recalled register

**Off:** Empty register

- 4 To recall data while holding the cross-point selections unchanged, press the following buttons, turning them on.

Block	Button pressed
M/E bank	[XPT HOLD] button in each cross-point control block
PGM/PST bank	
Key bus or AUX bus	[XPT/KY HOLD] button in AUX bus control block

- 5 Press the number of the timeline register you want to recall.

This recalls the timeline data saved in the register.

### For a temporary cross-point hold using the bus override function

Hold down a cross-point button in the M/E bank A bus or B bus (in the PGM/PST bank, the PGM bus or PST bus), and recall the timeline data.

The signal selection for the cross-point button held down does not change as the timeline data is recalled. This operation is unnecessary if cross-point hold is set.

## Executing a Timeline Effect

Execute (run) the timeline effect in the currently recalled register.

### Specifying the direction of execution of a timeline effect

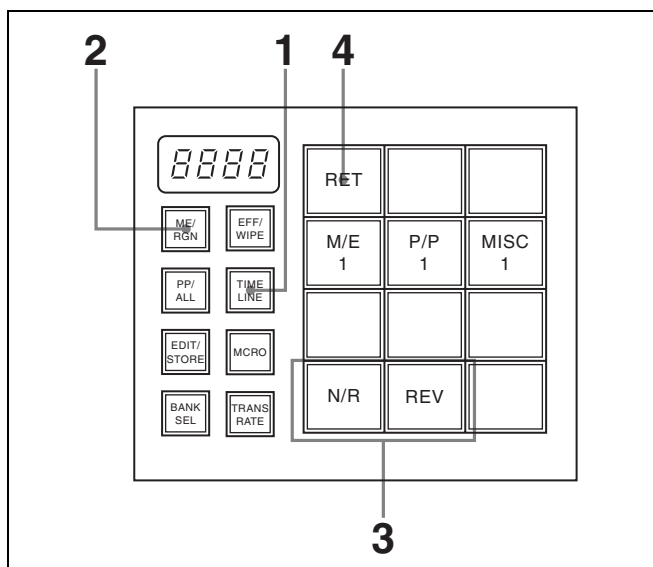

**1** In the Flexi Pad control block, press the [TIMELINE] button, lighting it in amber.

**2** In the Flexi Pad control block, press the [ME/RGN] button.

The memory recall buttons change as shown in the above figure.

**3** Press the [N/R] and [REV] buttons to set the execution direction.

- To run in the forward direction, set [N/R] and [REV] to off (lit orange).
- To run in the reverse direction, set [REV] to on (lit green).
- To alternate running the effect in the normal direction and the reverse direction, set [N/R] to on (lit green).

**4** Press the [RET] button.

The memory recall buttons change, and the timeline effect can now be executed.

### Executing a timeline effect in the Flexi Pad control block

In the Flexi Pad control block, press the [RUN] button. To return to the beginning of the timeline, press the [REWIND] button.

### Executing a timeline effect with the fader lever

If the function is first assigned to the [PST COLOR MIX] button, you can execute the transition effect with the fader lever.

**1** Press the [PST COLOR MIX] button, to assign the fader lever to timeline operations.

**2** Operate the fader lever.

### Executing a timeline effect with the joystick

If the “TL Run Control” command is first assigned to a utility button, you can execute the transition effect with the joystick.

**1** Press the utility control block button to which the command is assigned, turning it on.

**2** Operate the joystick to execute the timeline effect.

Holding down the button in the top of the joystick while operating it reduces the degree of change caused by the operation, to allow finer control. (Fine mode)

## Deleting Timeline Data

**1** In the Flexi Pad control block, press the [TIMELINE] button.

**2** Press the [BANK SEL] button, turning it on.

**3** Press the memory recall button to select a bank.

**4** Press the [EDIT/STORE] button, turning it on.

**5** Hold down the [TIMELINE] button, and press the memory recall button showing the required register number.

The pressed memory recall button goes off, and this deletes the data.

The [EDIT/STORE] button goes off.



Control block	Event
Flexi Pad control block	Recalling the following data <ul style="list-style-type: none"> <li>• Snapshots</li> <li>• Effect snapshots</li> <li>• Timeline effect execution and rewind, and selection of its execution direction</li> <li>• Start point setting of frame memory clip and its cue-up, playback, stop and loop on/off</li> <li>• VTR/disk recorder/Extended VTR cue-up, playback, stop and setting their start points</li> <li>• Recording to VTR or disk recorder</li> <li>• Independent key transition type selection</li> <li>• Independent key transition execution</li> <li>• Key on/off</li> </ul>
Utility control block	Recalling the functions assigned to buttons <sup>c)</sup>
Menu control block	<ul style="list-style-type: none"> <li>• Disk recorder/Extended VTR file recalling</li> <li>• Recalling frame memory clips</li> </ul>

a) Not found on 1 M/E panel.

b) In the case of an event that inserts or deletes a key, the key state at the time of event registration (inserted or not inserted) is also saved in the macro. When the macro is executed, the event is only replayed if the key state matches the saved state. (Example: For a macro with an event that deletes a key, when the macro is executed, if the key is inserted it is deleted, but otherwise nothing occurs as concerns keying.)

c) The operations of buttons to which one of Device 1 to Device 6, All Stop, Shuttle, Jog, Mcro Only Set, Mcro AT with Rate, Mcro AT with A/B, TL Run Control, or FM1 Clip to FM3 Clip is assigned are excluded.

d) Not found on 1.5 M/E panel.

### Pause event

To adjust the execution timing of a particular event (to delay the start of execution of the event by a particular time interval), you can store a special event which pauses macro execution. This event is called a “pause event”. When you store a pause event, you can set the interval for which the macro is paused (the pause duration) to any value in the range 1 to 999 frames. When the set time has elapsed, the macro is automatically executed.

### Pause zero event

By including a pause event with the time set to zero, you can make macro execution pause at the pause event.

## Creating a New Macro

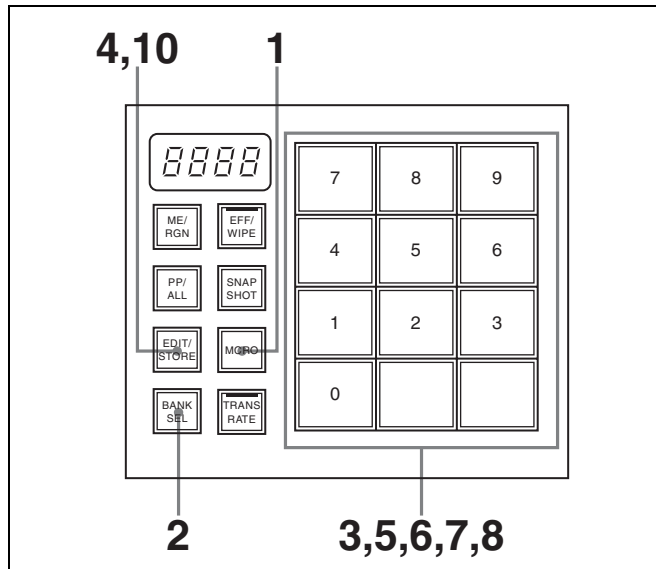

- 1 In the Flexi Pad control block, press the [MCRO] button, turning it on.

This assigns the Flexi Pad control block to macro operation.

- 2 Press the [BANK SEL] button, turning it on.

The display on the memory recall buttons changes to the state shown in the above figure. You can now select the save destination bank.

*For details of the correspondence between banks and registers, see page 154.*

- 3 Press a memory recall button to select a bank.

The most significant digit in the numeric display shows the number of the selected bank. Each memory recall button shows the corresponding register number and register status for the selected bank.

**Lit orange:** Register holding macro data

**Lit yellow:** Last recalled register

**Off:** Empty register

- 4 Press the [EDIT/STORE] button, turning it on.

- 5 Press the memory recall button showing the register number to be registered.

The Flexi Pad control block enters macro edit mode, and the [MCRO] button lights in red.

The memory recall buttons change as shown below.

**Note**

When the [TIMELINE] button is lit in red, the Flexi Pad control block cannot be put into macro edit mode.

EXIT	AUTO INS	STOR 01
PAUS		ALL
INS	MOD	DEL
	<< PREV	>> NEXT

Button name	Function
INS	Add a new event after the current event.
MOD	Modify an event.
DEL	Delete the current event, or delete all events within a macro register (when the [ALL] button is turned on).
PAUS	Enter pause duration input mode.
ALL	Specify all events within a macro register as editing targets.
EXIT	Exit macro edit mode without saving the edited macro.
AUTO INS	Enter auto insert mode.
STOR XX <sup>a)</sup>	Exit macro edit mode after saving the edited macro.
<< PREV	Go to the previous event.
>> NEXT	Go to the next event.

a) XX: The number of the register containing a macro being created or edited.

- 6 If required, press the [AUTO INS] button to toggle the auto insert mode on or off (*see the next item*).
- 7 Create the events (carry out the control panel operations to be registered as events in the macro).

You can include pause events (*see page 171*).

*For details of events that can be registered, see page 169.*

- When auto insert mode is on, execution of a control panel operation automatically registers an event in the macro.
- When auto insert mode is off, proceed to step 8.

**Note**

During macro creation or editing, if you press any of the mode selection buttons other than the [MCRO] button ([TRANSRATE] button, and so on), the executed operation is also registered as an event. In this case, the [MCRO] button stays lit red. To return to macro edit mode from this state, press the [MCRO] button.

- 8 When auto insert mode is off, press the [INS] button to register the event.
- 9 Repeat steps 7 and 8 to register the required events in the macro.

This registers the events in the macro, in the order the operations were carried out on the control panel. The numeric display appears as follows.

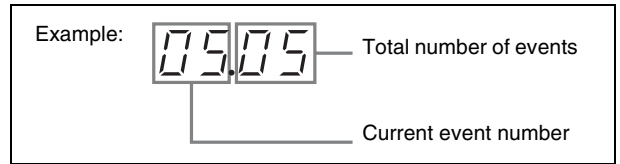

- 10 Press the [EDIT/STORE] button or memory recall button [STOR XX] (where XX is the register number).

This saves the created macro in the register, and the Flexi Pad control block returns to the state before macro editing began. The [MCRO] button lights amber.

**Switching auto insert mode on or off**

In the auto insert mode, when creating or editing a macro, an operation carried out on the control panel is automatically registered as an event.

By pressing the [AUTO INS] button, turning it in green, the auto insert mode is on.

When the [AUTO INS] button lights in orange (this mode is off), it is necessary to press the [INS] button for each operation to register the event.

**Note**

When you start macro creation or editing with the macro execution mode set to “Normal” (*see page 224*), the auto insert mode is automatically on. When “Step” is selected as the macro execution mode, the auto insert mode is automatically off.

**Creating a pause event**

To create a pause event, use the following procedure.

- 1 Press the memory recall button [PAUS].

The Flexi Pad control block enters pause duration input mode, and the memory recall buttons appear as in the following figure.

7	8	9
4	5	6
1	2	3
0	CLR	PAUS ENTR

**2** Enter the pause duration (0 to 999 (frames)).

If you set the duration to “0”, macro execution will be paused at the position of this pause event.

**3** Press the [PAUS ENTR] button.

This sets the pause duration, and inserts the pause event.

The appearance of the memory recall buttons returns to the before execution of step 1.

### Events requiring adjustment when creating a macro

The following event requires time for execution to complete, and therefore when executed within a macro sequence, a pause event must be inserted to adjust the timing.

- VTR/disk recorder/Extended VTR cue up

For a macro to cue up a VTR and then play back, for example, a pause event must be inserted between the cue up event and the playback event.

### To include all information associated with an operation when registering a macro event

When registering an auto transition operation as an event, you can register the auto transition event to include the transition rate and background A/B bus selection status. To use this capability, assign the following functions to buttons in the utility control block, and turn the relevant button on before you start an event to register.

**Macro AT with Rate (Macro Auto Trans Event with/without Rate):** When registering an auto transition macro event, include the transition rate.

**Macro AT with A/B Bus (Macro Auto Trans Event with/without A/B Bus):** When registering an auto transition macro event in the transition control block, include the background A/B bus cross-point.

For details of the method of assigning these functions to buttons, see “Utility Settings (Utility Menu)” (page 218).

## Recalling a Macro Register and Executing a Macro

There are two macro execution modes.

**Normal execution mode:** When execution of an event is completed, the next event is executed automatically.

**Step execution mode:** When execution of an event is completed, macro execution is paused.

You can switch the normal execution mode and step execution mode in the Setup/Diag >Operation >Macro menu. See “Macro Execution Mode Settings (Macro Menu)” (page 224).

When a macro is paused at a pause zero event or when a macro is paused in step execution mode, restarting such macro is referred to as a “macro take operation”.

## Executing a macro in normal execution mode

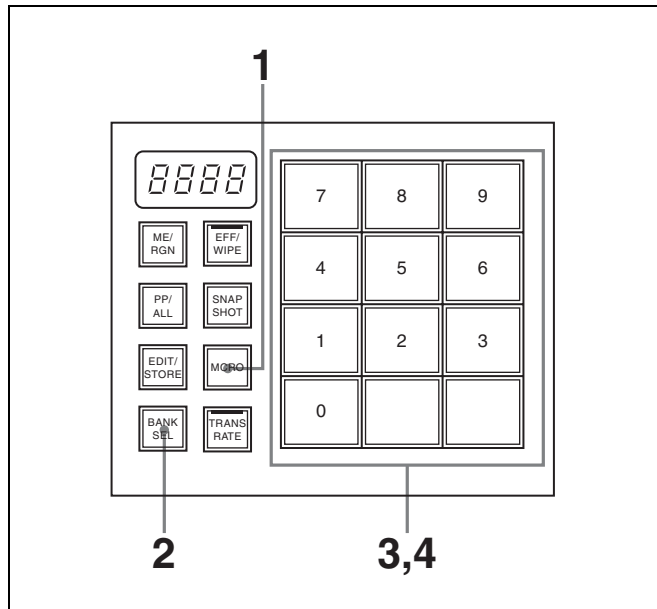

**1** In the Flexi Pad control block, press the [MCRO] button, turning it on.

This assigns the Flexi Pad control block to macro operation.

The numeric display shows the number of the bank selected last time, and the number of the register most recently recalled for the region.

**2** Press the [BANK SEL] button, turning it on.

The display on the memory recall buttons changes to the state shown in the above figure. You can now select the save destination bank.

For details of the correspondence between banks and registers, see page 154.

**3** Press a memory recall button to select a bank.

The most significant digit in the numeric display shows the number of the selected bank.

Each memory recall button shows the corresponding register number and register status for the selected bank.

**Lit orange:** Register holding macro data

**Lit yellow:** Last recalled register

**Off:** Empty register

- Press the memory recall button showing the register number to be recalled.

The button you pressed lights yellow, the macro register is recalled, and the macro is executed. During macro execution, the button you pressed remains yellow, but flashes. When macro execution completes, it returns to permanently on. The numeric display shows the bank number followed by the selected register number.

**Notes**

- It is not possible to execute more than one macro at a time.
- During macro execution, recalling the same register again stops the macro being executed.
- Individual events stored in a macro are executed according to the settings in setup. If you change the settings in setup, a saved macro may not have the expected effect.
- During macro execution, if you switch the control panel to macro edit mode, the macro being executed stops.
- During macro editing it is not possible to execute a macro.
- If you start execution of a macro by operating a button for which a macro attachment is set, then before the end of execution of that macro you cannot recall and execute a separate macro from the Flexi Pad control block.

**Executing a macro with pause zero events set**

When execution of a macro is paused, the memory recall button [TAKE] is lit in orange. To restart the macro execution, press the [TAKE] button.

**Executing a macro in step execution mode**

- In the Flexi Pad control block, recall the macro register.

*For details of recalling macro registers, see “Executing a macro in normal execution mode” (page 172).*

The memory recall buttons are assigned to the display of the [TAKE] button and macro execution status, as in the following figure.

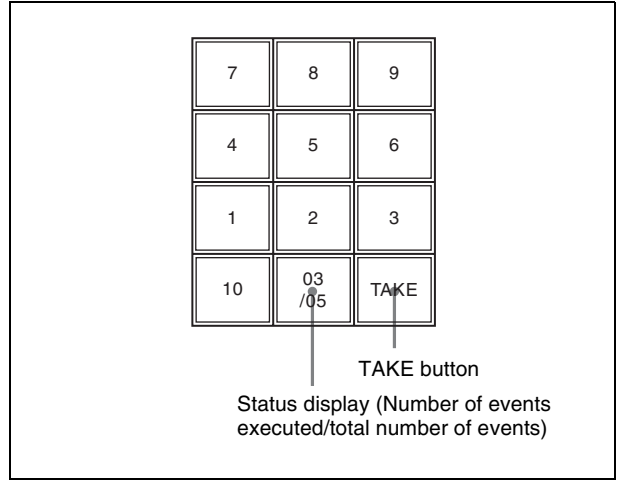

- Press the [TAKE] button.

This executes one event within the macro, then stops. The number of events executed, as shown in the memory recall button, is incremented by one.

- Repeat step 2, executing the macro event by event.

When all events in the macro have been executed, the [TAKE] button goes off.

**Editing a Macro**

After carrying out macro editing, be sure to carry out a save operation (*see page 174*).

**Specifying an edit point**

- In the Flexi Pad control block, press the [MCRO] button, turning it on.
- Press the [BANK SEL] button, turning it on.
- Press a memory recall button to select a bank.
- Press the [EDIT/STORE] button, turning it on.
- Press the memory recall button showing the register number to be edited.

The Flexi Pad control block enters macro edit mode, and the [MCRO] button lights in red.

*For details of the function assignment to the memory recall buttons in macro edit mode, see step 5 in “Creating a New Macro” (page 170)*

- 6** Specify the edit point by the following operation.
- To move the edit point to the event immediately following the current macro event (the macro event specified as the current edit point), press the [>>> NEXT] button.
  - To move the edit point to the event immediately preceding the current macro event, press the [<< PREV] button.

### Inserting an event

- 1** Specify the edit point. (*See previous item.*)
- 2** If required, press the [AUTO INS] button to toggle the auto insert mode on or off.
- 3** Carry out the event to be added on the control panel.

You can include pause events (*see page 171*).

- When auto insert mode is on, execution of a control panel operation automatically registers an event in the macro.
- When auto insert mode is off, proceed to step **4**.

*For details of events that can be registered, see page 169.*

- 4** When auto insert mode is off, press the memory recall button [INS].

This adds the new event after the event specified in step **1**.

### Modifying an event

- 1** Specify the edit point. (*See page 173.*)
- 2** If required, press the [AUTO INS] button to toggle the auto insert mode on or off.
- 3** Carry out the event you want to modify on the control panel.
- 4** Press the memory recall button [MOD].

This modifies the event at the specified edit point as carried out in step **3**.

### Deleting an event

- 1** Specify the edit point. (*See page 173.*)
  - 2** Press the memory recall button [DEL].
- This deletes the event specified in step **1**.

### Deleting all events within a macro register

- 1** Specify the edit point. (*See page 173.*)
- 2** Press the memory recall button [ALL], lighting it green.
- 3** Press the memory recall button [DEL].

This deletes all events within the register.

### Merging a macro for which a macro attachment is set

- 1** Specify the edit point. (*See page 173.*)
- 2** Press the memory recall button [AUTO INS] to toggle the auto insert mode on or off.

- 3** Press a button for which a macro attachment is set.

The macro in the register assigned to the button is merged with the macro being edited. However, the macro assigned to the button is not executed.

---

### Saving a Macro

Press the [EDIT/STORE] button or memory recall button [STOR XX] (where XX is the register number) to save the edited macro in a register.

#### To return to the state before editing, without saving the macro editing results

Press the memory recall button [EXIT] to recall the same register again. This returns to the state before editing, without saving the macro editing results.

---

### Deleting a Macro

- 1** In the Flexi Pad control block, press the [MCRO] button.
- 2** Press the [BANK SEL] button, turning it on.
- 3** Press a memory recall button to select a bank.
- 4** Press the [EDIT/STORE] button, turning it on.
- 5** Hold down the [MCRO] button, and then press the memory recall button showing the corresponding register number.

The button you pressed goes off, and this deletes the macro.

The [EDIT/STORE] button goes off.

## Using Macro Attachment

Macro attachment is a function whereby a macro register is assigned to a control panel button, linking the execution of the button function with a macro execution.

Select one of the following three linking modes to make the macro attachment.

**Pre macro:** Mode in which the button function is executed after macro execution has completed

**Post macro:** Mode in which the macro is executed after carrying out the button function

**Macro only:** Mode in which the button function is not executed, and the macro only is executed

The selection of pre or post macro mode is carried out in the macro control block. For macro only mode, assign the selection function to a utility control block button, and make the selection by pressing the button.

You can assign any one of the 99 macro registers to a button.

For a button whose function is switched by delegation, you can make a separate macro attachment for each function. You can make up to 999 macro attachment settings.

The macro attachment setting is possible for the following bus buttons. For button locations, see pages in parentheses.

Control block	Button
M/E cross-point control block	Cross-point buttons (page 13)
PGM/PST cross-point control block <sup>a)</sup>	Cross-point buttons (page 14)
AUX bus control block	Cross-point buttons (page 16)
M/E transition control block	[AUTO TRANS] button (page 17)
	[CUT] button (page 17)
	Transition type selection buttons (page 18)
	[KEY1 ON] to [KEY2 ON] buttons <sup>b) c)</sup> (page 18)
PGM/PST transition control block <sup>a)</sup>	Transition type selection buttons (page 18)
	[AUTO TRANS] button (page 18)
	[CUT] button (page 18)
M/E key transition control block <sup>a)</sup>	[AUTO TRANS] button <sup>b)</sup> (page 19)
	[KEY1 ON] to [KEY2 ON] buttons (page 19)
Downstream key/fade to black control block	[AUTO TRANS] button <sup>b)</sup> (page 19)
	[DSK1 ON] to [DSK2 ON] buttons <sup>c)</sup> (page 19)
	[FTB] button (page 19)

Control block	Button
Utility control block	DEVICE/UTILITY operation buttons <sup>d)</sup> (page 24)
	ENABLE/UTILITY operation buttons <sup>d)</sup> (page 24)
Flexi Pad control block	In timeline mode: [REWIND] button, [RUN] button
	In device control mode: [PLAY] button, [STOP] button, [CUE] button and [START TC] button
	In key transition mode: [MIX] button, [EFF] button, [KEY ON] button and [AUTO TRANS] button

a) Not found on 1 M/E panel.

b) When you attach macros to buttons that turn independent key transitions on and off, operations which go from on to off are distinguished from operations which go from off to on. For example, if you attach a macro to an operation which uses a button to go from on to off, the macro is not executed when you press the same button to go from off to on.

c) Not found on 1.5 M/E panel.

d) Excluding the buttons to which one of Device 1 to Device 6, All Stop, Shuttle, Jog, Rec, Mcro Only Set, Mcro AT with Rate, Mcro AT with A/B, TL Run Control, M/E K1 Trans, M/E K2 Trans, Effect/Wipe, Snapshot, Macro, Transition Rate, Timeline, Device Control, FM1 Clip to FM3 Clip, FM1 V Clip, FM1 K Clip, FM2 V Clip, FM2 K Clip, FM3 V Clip, FM3 K Clip, or FM Loop is assigned.

## Setting a macro attachment

See above for the buttons for which a macro attachment can be set.

- 1 Recall the macro register you want to assign to the button.

*For details of the method of operation, see “Executing a macro in normal execution mode” (page 172).*

- 2 To set in macro only mode, press the button to which [Mcro Only Set] is assigned, turning it on.

To set in pre or post macro mode, proceed to step 3.

### Notes

- To set in macro only mode, it is first necessary to assign the “Macro Only Set” function to the buttons in the utility control block. Carry out this assignment in the Setup/Diag >Operation >Utility menu. *For details, see “Utility Settings (Utility Menu)” (page 218).*
- Without switching to macro only mode, if you hold down the [PRE MCRO] and [POST MCRO] buttons together and press the desired button, it is possible to set a macro attachment in macro only mode for that button.

**3** Depending on the macro attachment mode you want to set, carry out any of the following operations in the macro control block.

**Pre macro:** Hold down the [PRE MCRO] button, and press the desired button.

**Post macro:** Hold down the [POST MCRO] button, and press the desired button.

**Macro only:** Hold down the [PRE MCRO] button or [POST MCRO] button, and press the desired button.

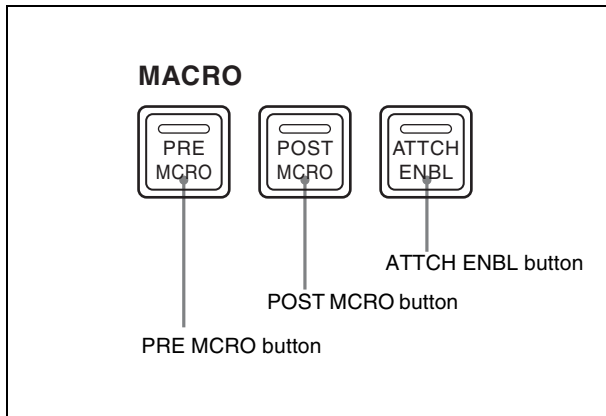

The button you pressed flashes, and the register you recalled in step 1 is assigned to the button. (When you set in macro only mode, the button to which [Macro Only Set] is assigned goes off.)

- Buttons set in pre- or post-macro mode: flash amber
- Buttons set in macro only mode: flash green

### To check macro attachment settings

Hold down the [PRE MCRO] button or [POST MCRO] button. While it is held down, buttons for which macro attachments are set flash as follows.

**While the [PRE MCRO] button is held down:**

- Buttons set in pre macro mode: flash amber
- Buttons set in macro only mode: flash green

**While the [POST MCRO] button is held down:**

- Buttons set in post macro mode: flash amber
- Buttons set in macro only mode: flash green

### If you set a macro attachment for an already macro attached button

It results in either of the following.

**When the new setting is made in the same macro attachment mode as for the old setting:** Both old and new settings are invalid.

**When the new setting is made in a different macro attachment mode from the old setting:** The new setting is valid.

### Note

After setting a macro attachment to a cross-point button in the cross-point control block, if in the Setup menu you change the function assignment to the button, the macro attachment setting disappears.

## Removing macro attachment settings

Hold down the [PRE MCRO] button or [POST MCRO] button, and press a button that is flashing. The button for which the macro attachment is set stops flashing and goes off, and this removes the setting. (See above.)

## Executing a macro by macro attachment

**1** Press the [ATTCH ENBL] button, turning it on.

**2** Press the desired button for which a macro attachment has been set.

This recalls the macro register assigned to the button, and the macro is executed as follows, according to the operation mode.

**Pre macro mode:** The macro is executed first, and then the button function is executed.

**Post macro mode:** The button function is executed first, and then the macro is executed.

**Macro only mode:** The button function is not executed, and the macro only is executed.

### Notes

- It is not possible to execute more than one macro at a time. Therefore, even if you simultaneously press multiple buttons for which macro attachments are set, only one macro is executed.
- During macro execution, recalling the same register again stops the macro being executed. Therefore, pressing twice a button for which a macro attachment is set stops the macro being executed.
- Individual events stored in a macro are executed according to the settings in setup. If you change the settings in setup, a saved macro may not have the expected effect.
- During macro execution, if you switch the Flexi Pad control block to macro edit mode, the macro being executed stops.
- During macro editing, pressing a button for which a macro attachment is set does not execute the macro.

### To disable macro attachment settings

Press the [ATTCH ENBL] button, turning it off.

In this state, pressing a button for which a macro attachment is set does not execute the macro.

## Editing Macro Registers

You can edit macro registers in the following ways.

**Rename:** Change the name of the register.

**Lock:** Prevent editing operations (overwriting and deleting of data in the register, and renaming of the register).

**Delete:** Delete the data in the register.

## Renaming macro registers

- 1 From the top menu, select Register >Macro >Edit.

The Edit menu appears.

- 2 Do one of the following to select the register.

- Press directly on the list appearing in the status area.
- Use the arrow buttons to scroll the reverse video cursor.
- Turn the knob.

Knob	Description	Setting values
1 (Reg No)	Register number	1 to 99

The selected register appears in reverse video.

- 3 Press [Rename].

The keyboard window appears.

See “Keyboard window” (page 40) in Chapter 3 for more information about keyboard window operations.

### Note

If you pressed [Select All], turning it on, or if you selected several registers, the register with the lowest number in the selected range is the target of the operation.

- 4 Enter a name of up to eight characters, and then press [Enter].

The specified name appears in the list.

### Note

The following names cannot be used:  
 CON, PRN, AUX, CLOCK\$, NUL, COM0, COM1,  
 COM2, COM3, COM4, COM5, COM6, COM7,  
 COM8, COM9  
 LPT0, LPT1, LPT2, LPT3, LPT4, LPT5, LPT6, LPT7,  
 LPT8, LPT9

## Preventing editing of macro registers (locking the registers)

- 1 In the Edit menu, do one of the following to select the register.

- Press directly on the list appearing in the status area.
- Use the arrow buttons to scroll the reverse video cursor.
- Turn the knobs.

Knob	Description	Setting values
1 (Reg No)	Register number	1 to 99

Knob	Description	Setting values
2 (Number)	Number of registers	1 to 99

- To select all registers, press [Select All], turning it on.

The selected register appears in reverse video.

- 2 Press [Lock], turning it on.

### To unlock the register

Select the register to unlock, and then press [Lock], turning it off.

## Deleting the data in macro registers

Proceed as follows.

- 1 In the Edit menu, do one of the following to select the register.

- Press directly on the list appearing in the status area.
- Use the arrow buttons to scroll the reverse video cursor.
- Turn the knobs.

Knob	Description	Setting values
1 (Reg No)	Register number	1 to 99
2 (Number)	Number of registers	1 to 99

- To select all registers, press [Select All], turning it on.

The selected register appears in reverse video.

- 2 Press [Delete].

A message appears asking you to confirm the deletion.

- 3 Press [Yes] to execute the deletion, or [No] to cancel it.

If you pressed [Yes], the deletion is executed.

If you pressed [No], you return to the state before step 2.

### Note

Data in locked registers cannot be deleted.

---

# Safe Title

Safe title is a function which allows you to check whether that text you add with keys falls within the effective reception area of television receivers, which is indicated by a box marker appearing on the monitor screen. This function also allows you to display a cross marker which indicates the center of the screen.

See “Making safe title settings” (page 218) for more information about marker types and other safe settings.

## Displaying safe title markers from menus

- 1 From the top menu, select Misc >Enable >Enable/Safe Title.

The Enable/Safe Title menu appears.

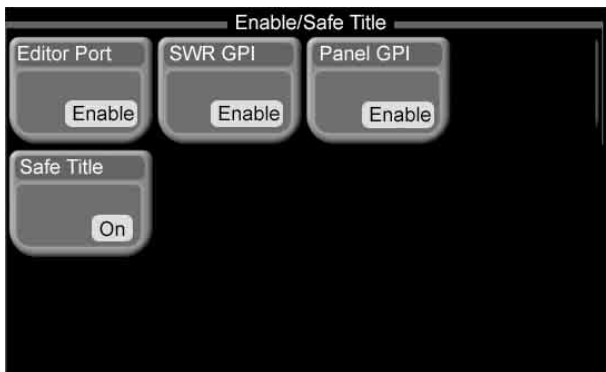

- 2 Press [Safe Title].

Safe title markers appear.

## Displaying safe title markers with a button operation

Press [SAFE TITLE] in the ENABLE/UTILITY operation button row on the control panel.

See “Utility Settings (Utility Menu)” (page 218) for information about how to assign the safe title on/off command to the [SAFE TITLE] button.

---

# Copying

---

## Copy Operation Targets

You can copy setting states between the following four keys.

Setup data and key memory data is not copied.

- M/E key 1
- M/E key 2
- Downstream key 1 (DSK1)
- Downstream key 2 (DSK2)

---

## Using Buttons to Copy Key Settings

You can easily copy keyer settings by using the AUX delegation buttons ([KEY1], [KEY2], [DSK1], and [DSK2]) in the AUX bus control block to specify the copy source and copy destination.

### Example: Copying M/E key 1 to M/E key 2

In the AUX bus control block (see page 15), hold down the [KEY 1] delegation button and press the [KEY 2] button. A beep sounds and the copy is executed.

## Overview

You can save register data, including setup data and snapshot data, and load the saved data whenever it is needed. Data can be saved to either the built-in hard disk or a “Memory Stick” (*see page 26*) as a file.

The system distinguishes between several different kinds of data.

- Setup data (including data on the states of system devices after system power on and key memory setting data)
- Snapshot setting data
- Effect snapshot setting data
- Frame memory still image data
- Macro setting data
- Macro attachment setting data
- Timeline effect setting data
- User programmable DME data

You can do the following with data in the above categories.

- Save, load, and delete all data in all categories (except frame memory still image data) in a single operation.
- Save, load, and delete all data in selected categories in a single operation.
- Save, load, delete, rename, and copy files containing data in all categories (except user programmable DME data).
- Import and export image files, and import user programmable DME effects.

You can also create, rename, delete, and lock directories.

### Notes

- Data saved to hard disk may become unavailable if trouble occurs on the hard disk. It is recommended that important data be backed up to “Memory Stick”.

- Before saving data to a “Memory Stick” or loading or deleting data from a “Memory Stick”, insert the “Memory Stick” into the system’s “Memory Stick” slot.

# Batch Operating on Data Files

Use the File >All menu to operate on data in all categories (except frame memory image data).

## Saving All Data at Once

1 From the top menu, select File >All.

The All menu appears.

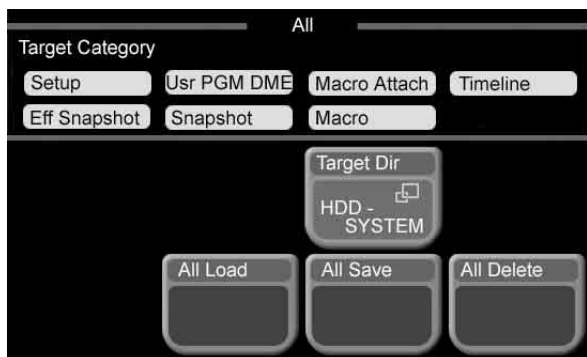

2 Press [Target Dir].

A popup window appears.

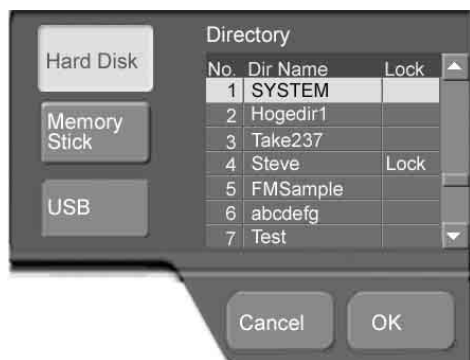

3 Press the button for the desired media type (Hard Disk, Memory Stick, or USB).

The color of the pressed button is inverted.

4 Do one of the following to select the directory.

- Press directly on the list.
- Use the arrow buttons to scroll the reverse video cursor.
- Turn the knob.

Knob	Description	Setting values
1 (Directory)	Directory selection	1 and upwards

5 Press [OK].

The popup window closes.

6 In the File >All menu, press [All Save].

A confirmation window appears asking if you want to execute the save.

7 Press [Yes] in the confirmation window to execute the save, or [No] to cancel it.

If you pressed [Yes], the save begins and a window opens to show its progress.

Note that all existing files in the save destination are deleted before the save starts.

### To cancel a save after it has started

Press [Cancel] in the progress window, and press [OK] in the message box which appears to inform you that the save has been cancelled.

## Loading All Data at Once

You can load the data of all categories saved in files to registers in a single operation.

### Note

Data cannot be loaded from files created or saved on systems other than the MFS-2000.

1 Carry out steps 1 to 4 in “Saving All Data at Once” (see page 180), to select the type of media storing the data you want to load.

2 In the File >All menu, press [All Load].

A confirmation window appears asking if you want to execute the load.

3 Press [Yes] in the confirmation window to execute the load, or [No] to cancel it.

If you pressed [Yes], the load begins and a window opens to show its progress.

Note that all existing data in the load destination registers are deleted before the load starts.

### Note

User programmable DME data is not loaded when you have selected EFF (the effect pattern number is 1001 or higher) as the transition type.

Operate after pressing the [MIX] button in the M/E transition control block to change the transition type.

### To cancel a load after it has started

Press [Cancel] in the progress window, and press [OK] in the message box which appears to inform you that the save has been cancelled.

## Deleting All Data at Once

You can delete the data of all categories saved in files in a single operation.

- 1 Carry out steps 1 to 5 of “Saving All Data at Once” (see page 180), to select the type of media storing the data you want to delete.
- 2 In the File >All menu, press [All Delete].  
A confirmation window appears asking if you want to execute the deletion.
- 3 Press [Yes] in the confirmation window to execute the deletion, or [No] to cancel it.

If you pressed [Yes], the deletion begins and a window opens to show its progress.

### To cancel the data deletion after it has started

Press [Cancel] in the progress window, and press [OK] in the message box which appears to inform you that the deletion has been cancelled.

## Batch Operating on Data Files of Selected Categories

Use the File >All (Selected) menu to operate on data in selected categories.

## Saving the Data of Selected Categories

You can save the data for one or more categories in a single operation.

- 1 From the top menu, select File >All (Selected).

The All (Selected) menu appears.

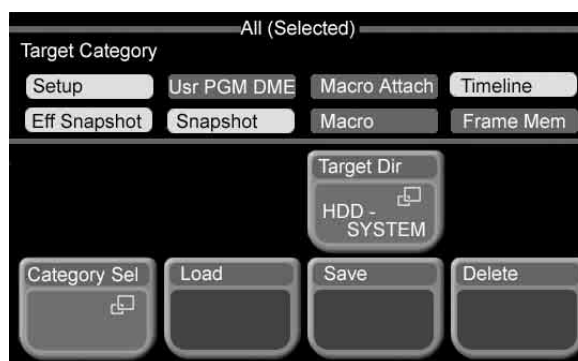

In the Target Category area, the names of the currently selected categories are displayed in reverse video.

- 2 To change the category selection, press [Category Sel].

A popup window appears.

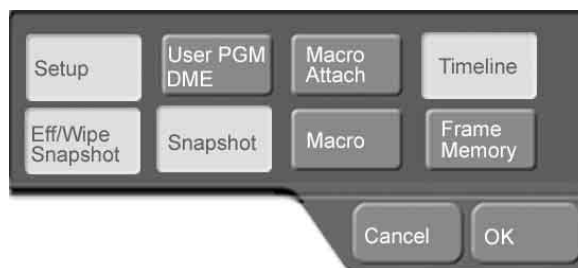

The buttons for the currently selected categories are on (their color is inverted).

- 3 Press the button for the category that you want to select (multiple selections possible). To deselect a category, press the corresponding (on) button, turning it off.

**4** When you are finished selecting categories, press [OK].

The popup window closes.

**5** In the File >All (Selected) menu, press [Target Dir].

A popup window opens, in the same way as in step **2** of “Saving All Data at Once” (*see page 180*).

**6** Press the button for the desired media type (Hard Disk, or Memory Stick).

The color of the pressed button is inverted.

**7** Do one of the following to select the directory.

- Press directly on the list.
- Use the arrow buttons to scroll the reverse video cursor.
- Turn the knob.

Knob	Description	Setting values
1 (Directory)	Directory selection	1 and upwards

**8** Press [OK].

The popup window closes.

**9** In the File >All (Selected) menu, press [Save].

A confirmation window appears asking if you want to execute the save.

**10** Press [Yes] in the confirmation window to execute the save, or [No] to cancel it.

If you pressed [Yes], the save begins and a window opens to show its progress.

Note that all existing files in the save destination are deleted before the save starts.

**To cancel a save after it has started**

Press [Cancel] in the progress window, and press [OK] in the message box which appears to inform you that the save has been cancelled.

---

## Loading the Data of Selected Categories

You can load the data for one or more categories to registers in a single operation.

**1** Carry out steps **1** to **8** of “Saving the Data of Selected Categories” (*see page 181*), to select the type of media storing the data, directory, and categories.

**2** In the File >All (Selected) menu, press [Load].

A confirmation window appears asking if you want to execute the load.

**3** Press [Yes] in the confirmation window to execute the load, or [No] to cancel it.

If you pressed [Yes], the load begins and a window opens to show its progress.

Note that all existing data in the load destination registers are deleted before the load starts.

**Note**

User programmable DME data is not loaded when you have selected EFF (the effect pattern number is 1001 or higher) as the transition type.

When [Usr PGM DME] is selected as the category, operate after pressing the [MIX] button in the M/E transition control block to change the transition type.

**To cancel a load after it has started**

Press [Cancel] in the progress window, and press [OK] in the message box which appears to inform you that the save has been cancelled.

---

## Deleting the Data of Selected Categories

You can delete the data for one or more categories saved in files in a single operation.

**1** Carry out steps **1** to **8** of “Saving the Data of Selected Categories” (*see page 181*), to select the target categories, the type of media and the directory storing the data you want to delete.

**2** In the File >All (Selected) menu, press [Delete].

A confirmation window appears asking if you want to execute the deletion.

**3** Press [Yes] in the confirmation window to execute the deletion, or [No] to cancel it.

If you pressed [Yes], the deletion begins and a window opens to show its progress.

**To cancel the data deletion after it has started**

Press [Cancel] in the progress window, and press [OK] in the message box which appears to inform you that the deletion has been cancelled.

# Operating on Individual Data Files

You can save, load, delete, rename, and copy files containing data in all categories (except user programmable DME data).

## Loading Data Files

Proceed as follows to load the data in media files into system registers.

- 1 From the top menu, select File >Load.  
A popup window appears.
- 2 Select the category (type of data) targeted by the operation.  
A Load menu for the selected category appears. (You can press [Category Sel] to change the category.)

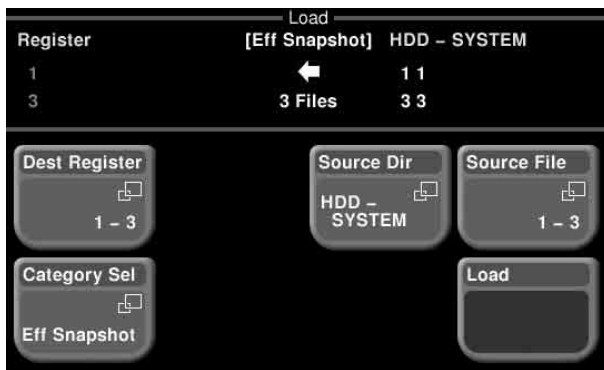

The media, directory, files, and registers used in the previous load operation appear in the status area. When you have selected frame memory as the category, the [Clip View] button appears.

- To display only clip files, turn [Clip View] On.
- To display all files, turn [Clip View] Off.

- 3 Change the category as required, and select the target media and directory.

*For details about the procedure, see “Common Operations – Selecting Categories, Media, and Directories” (page 191).*

- 4 In the File >Load menu, press [Source File].  
A file list appears in a popup window.
- 5 Do one of the following to select the files to load.
  - Press directly on the list in the popup window.

- Use the arrow buttons to scroll the reverse video cursor.
- Turn the knobs.

Knob	Description	Setting values
1 (Start File)	Number of first file to load	1 and upwards
2 (Number)	Number of files to load	1 and upwards

- 6 When you are finished selecting files, press [OK].  
The popup window closes.

- 7 Press [Dest Register].

A list of destination registers appears in a popup window.

- 8 Do one of the following to select the destination registers.

- Press directly on the list in the popup window.
- Use the arrow buttons to scroll the reverse video cursor.
- Turn the knobs.

Knob	Description	Setting values
1 (Start Reg)	Number of first destination register	1 and upwards
2 (Number)	Number of destination registers	1 and upwards

- 9 When you are finished selecting registers, press [OK].  
The popup window closes.

- 10 Press [Load].

A confirmation window appears asking if you want to execute the load.

- 11 Press [Yes] in the confirmation window to execute the load, or [No] to cancel it.

If you pressed [Yes], the load begins and a window opens to show its progress.

Note that all existing files in the destination registers are deleted before the load begins.

### To cancel a load after it has started

Press [Cancel] in the progress window, and press [OK] in the message box which appears to inform you that the load has been cancelled.

## Saving Data Files

You can save the data that has been loaded into registers to files in a directory on the desired type of media.

See the previous section “Loading Data Files” for more information about how to load the data files.

- From the top menu, select File >Save.  
A popup window appears.
- Select the category (type of data) targeted by the operation.  
A Save menu for the selected category appears. (You can press [Category Sel] to change the category.)

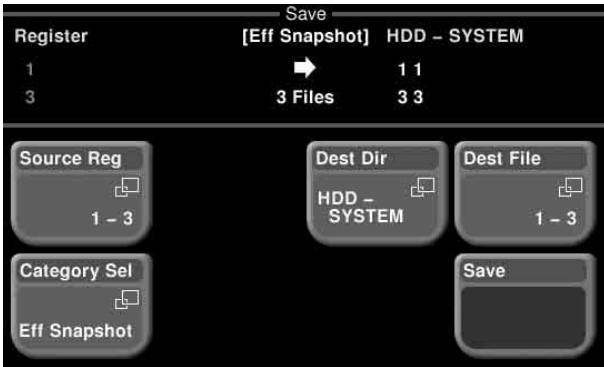

The media, directory, files, and registers used in the previous save operation appear in the status area. When you have selected frame memory as the category, the [Clip View] button appears.

- To display only clip files, turn [Clip View] On.
- To display all files, turn [Clip View] Off.

- Change the category as required, and select the target media and directory.  
*For details about the procedure, see “Common Operations – Selecting Categories, Media, and Directories” (page 191).*
- To change the save source registers, press [Source Reg] in the File >Save menu.  
A register list appears in a popup window.
- Do one of the following to select the registers to save.
  - Press directly on the list in the popup window.
  - Use the arrow buttons to scroll the reverse video cursor.
  - Turn the knobs.

Knob	Description	Setting values
1 (Start Reg)	Number of first register to save	1 and upwards
2 (Number)	Number of registers to save	1 and upwards

- When you are finished selecting registers, press [OK].

The popup window closes.

- Press [Dest File].  
A list of destination files appears in a popup window.
- Do one of the following to select the destination files.
  - Press directly on the list in the popup window.
  - Use the arrow buttons to scroll the reverse video cursor.
  - Turn the knobs.

Knob	Description	Setting values
1 (Start File)	Number of first destination file	1 and upwards
2 (Number)	Number of destination files	1 and upwards

- When you are finished selecting files, press [OK].  
The popup window closes.
- Press [Save].  
A confirmation window appears asking if you want to execute the save.
- Press [Yes] in the confirmation window to execute the load, or [No] to cancel it.  
If you pressed [Yes], the save begins and a window opens to show its progress.

**To cancel a save after it has started**

Press [Cancel] in the progress window, and press [OK] in the message box which appears to inform you that the save has been cancelled.

## Deleting Data Files

Proceed as follows to delete a data file that has been saved to media.

- From the top menu, select File >Delete.  
A confirmation window appears asking if you want to execute the deletion.
- Select the category (type of data) targeted by the operation.  
A Delete menu for the selected category appears. (You can press [Category Sel] to change the category.)

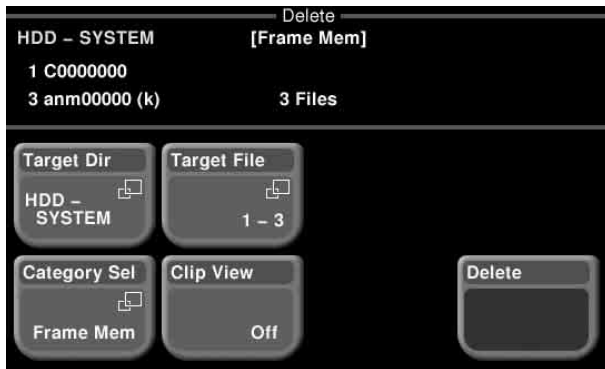

The media, directory, and files used in the previous delete operation appear in the status area.

When you have selected frame memory as the category, the [Clip View] button appears.

- To display only clip files, turn [Clip View] On.
- To display all files, turn [Clip View] Off.

- 3 Change the category as required, and select the target media and directory.

*For details about the procedure, see “Common Operations – Selecting Categories, Media, and Directories” (page 191).*

- 4 In the File >Delete menu, press [Target File].

A file list appears in a popup window.

- 5 Do one of the following to select the files to delete.

- Press directly on the list in the popup window.
- Use the arrow buttons to scroll the reverse video cursor.
- Turn the knobs.

Knob	Description	Setting values
1 (Start File)	Number of first file to delete	1 and upwards
2 (Number)	Number of files to delete	1 and upwards

- 6 When you are finished selecting files, press [OK].

The popup window closes.

- 7 In the File >Delete menu, press [Delete].

A confirmation window appears asking if you want to execute the deletion.

- 8 Press [Yes] in the confirmation window to execute the deletion, or [No] to cancel it.

If you pressed [Yes], the deletion begins and a window opens to show its progress.

### To cancel a file deletion after it has started

Press [Cancel] in the progress window, and press [OK] in the message box which appears to inform you that the deletion has been cancelled.

## Renaming Data Files

Proceed as follows to rename a data file that has been saved to media.

- 1 From the top menu, select File >Rename.

A popup window appears.

- 2 Select the category (type of data) targeted by the operation.

A Rename menu for the selected category appears. The Rename menu appears. (You can press [Category Sel] to change the category.)

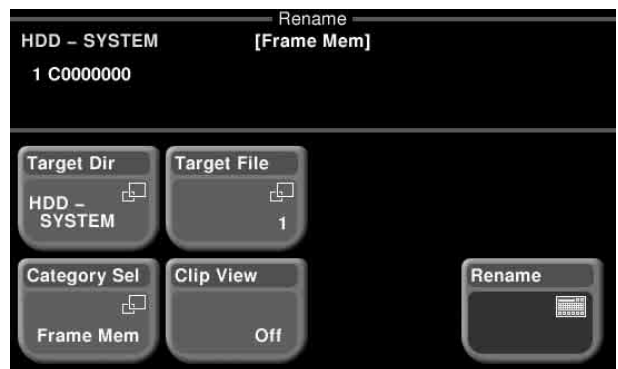

The media, directory, and files used in the previous rename operation appear in the status area.

When you have selected frame memory as the category, the [Clip View] button appears.

- To display only clip files, turn [Clip View] On.
- To display all files, turn [Clip View] Off.

- 3 Change the category as required, and select the target media and directory.

*For details about the procedure, see “Common Operations – Selecting Categories, Media, and Directories” (page 191).*

- 4 In the File >Rename menu, press [Target File].

A file list appears in a popup window.

- 5 Do one of the following to select the file to rename.

- Press directly on the list in the popup window.
- Use the arrow buttons to scroll the reverse video cursor.
- Turn the knob.

Knob	Description	Setting values
1 (Start No)	Number of file to rename	1 and upwards

**6** When you are finished selecting the file, press [OK].  
The popup window closes.

**7** Press [Rename].  
A keyboard window (see page 40) appears.

**8** Enter the desired file name in the keyboard window (maximum length eight characters) and press [Enter].  
Renaming process starts and its progress is displayed in a window.

### Notes

- You cannot use the following characters in file names.  
space \ / : ; , (comma) . (period) < > \* ? “ |
- The following names cannot be used:  
CON, PRN, AUX, CLOCK\$, NUL, COM0, COM1, COM2, COM3, COM4, COM5, COM6, COM7, COM8, COM9  
LPT0, LPT1, LPT2, LPT3, LPT4, LPT5, LPT6, LPT7, LPT8, LPT9

## Copying Data Files

Proceed as follows to copy a data file that has been saved to media.

**1** From the top menu, select File >Copy.  
A popup window appears.

**2** Select the category (type of data) targeted by the operation.

A Copy menu for the selected category appears. (You can press [Category Sel] to change the category.)

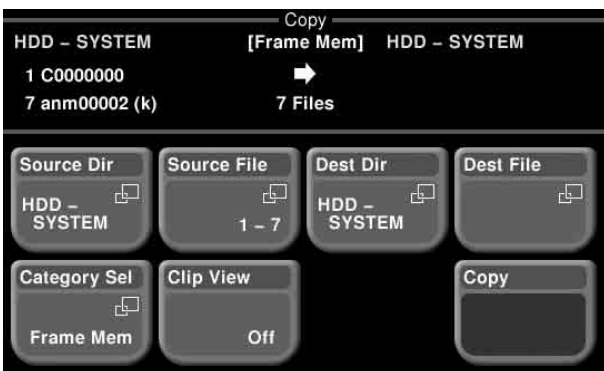

The media, directories, and files used in the previous copy operation appear in the status area.

When you have selected frame memory as the category, the [Clip View] button appears.

- To display only clip files, turn [Clip View] On.
- To display all files, turn [Clip View] Off.

**3** Change the category as required, and select the target media and directory.

*For details about the procedure, see “Common Operations – Selecting Categories, Media, and Directories” (page 191).*

**4** In the File >Copy menu, press [Source File].

A list of copy source files appears in a popup window.

**5** Do one of the following to select the copy source files.

- Press directly on the list in the popup window.
- Use the arrow buttons to scroll the reverse video cursor.
- Turn the knobs.

Knob	Description	Setting values
1 (Start File)	Number of first copy source file	1 and upwards
2 (Number)	Number of copy source files	1 and upwards

**6** When you are finished selecting files, press [OK].

The popup window closes.

**7** If you want to copy the files to a different type of media, execute steps **3** and **4** in “Common Operations – Selecting Categories, Media, and Directories” (page 191).

**8** Press [Dest File].

A list of destination files appears in a popup window.

**9** Do one of the following to select the copy destination files.

- Press directly on the list in the popup window.
- Use the arrow buttons to scroll the reverse video cursor.
- Turn the knobs.

Knob	Description	Setting values
1 (Start File)	Number of first copy destination file	1 and upwards
2 (Number)	Number of copy destination files	1 and upwards

**10** When you are finished selecting files, press [OK].

The popup window closes.

## 11 Press [Copy].

A confirmation window appears asking if you want to execute the copy.

## 12 Press [Yes] in the confirmation window to execute the copy, or [No] to cancel it.

If you pressed [Yes], the copy begins and a window opens to show its progress.

### To cancel a file copy after it has started

Press [Cancel] in the progress window, and press [OK] in the message box which appears to inform you that the copy has been cancelled.

# Importing and Exporting Data

On this system, you can import and export files in standard image formats, and import user programmable DME effects created on switchers such as the MVS-8000 series.

## Importing Image Files

On this system, you can import image files in the following formats.

File type	Format	File name	Notes
TIFF file	RGB uncompressed format	Maximum eight characters, plus extension .tif required	<ul style="list-style-type: none"><li>Layers cannot be used.</li><li>If an alpha channel is present, two files are created as a pair.</li></ul>
BMP file	Windows <sup>a)</sup> 24-bit format	Maximum eight characters, plus extension .bmp required	–
TARGA file	RGB uncompressed format	Maximum eight characters, plus extension .tga required	<ul style="list-style-type: none"><li>Layers cannot be used.</li><li>If an alpha channel is present, two files are created as a pair.</li></ul>
	RGB compressed format		

a) Windows is a registered trademark or trademark of Microsoft Corporation in the United States and/or other countries.

### Note

This functionality has been tested and confirmed to work with TIFF files created by Photoshop, but it may not be possible to use TIFF files created with some other software. (Photoshop is a trademark of Adobe Systems Incorporated.)

### Import image dimensions

The dimensions of imported images to fill the full screen vary as follows, depending on the current video format of this system.

**SD (480i):** 720 × 487 pixels

**SD (576i):** 720 × 576 pixels

**HD (1080i):** 1920 × 1080 pixels

**HD (720P):** 1280 × 720 pixels

Images are pasted with their upper left corners as the origin. When images are smaller than the listed dimensions, the remainder is filled with black. When they are larger, the excess part is discarded.

**Notes**

- No pixel ratio conversion is performed when images are imported for SDTV formats. When you are using the 480i/59.94 format, the equivalent dimensions on a computer screen are 720 × 540, but if you create a 720 × 540 image on a computer and then import it just as it is, the image will be too tall. To maintain the shape of the image, first create it as a 720 × 540 image, and then use a computer software tool to compress the vertical dimension to 487 pixels before importing it. The same applies when you are using the 576i/50 format.
- To import movie material in 720P format, it is necessary to treat each frame as a separate image file.

**1** From the top menu, select File >Import >Frame Memory.

The Import menu for frame memory appears.

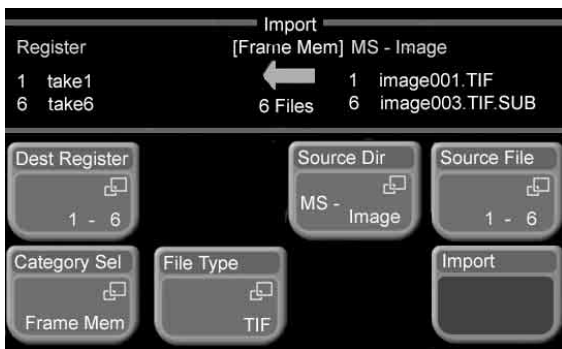

The media, directories, files, and registers used in the previous import operation appear in the status area.

**2** As required, select the target media and directory of the operation.

*For details about the procedure, see steps 3 to 6 in “Common Operations – Selecting Categories, Media, and Directories” (page 191).*

**3** Press [File Type].

A popup window appears so that you can select the file format.

**4** Select the format of the files to import from among the following.

- BMP
- TIF (TIFF)
- TGA (Targa)

**5** Press [Source File].

A list of files on the import source media appears in a popup window.

This is a list of files in the format selected in step 4.

**About file names**

Files with an alpha channel are displayed as two files: video and key. For example, the file “image007.TIF” is displayed as “image007.TIF” (video side) and “image007.TIF (a)” (key side).

**6** Do one of the following to select the files to import.

- Press directly on the list.
- Use the arrow buttons to scroll the reverse video cursor.
- Turn the knobs.

Knob	Description	Setting values
1 (Start File)	Number of first file to import	1 and upwards
2 (Number)	Number of files to import	1 and upwards

**7** When you have selected the files, press [OK].

The popup window closes.

**8** Press [Dest Register].

A register list appears in a popup window.

**9** Do one of the following to select the import destination registers.

- Press directly on the list.
- Use the arrow buttons to scroll the reverse video cursor.
- Turn the knobs.

Knob	Description	Setting values
1 (Start Reg)	Number of first import destination register	1 and upwards
2 (Number)	Number of import destination registers	1 and upwards

**10** When you have selected the registers, press [OK].

The popup window closes.

**11** Press [Import].

A confirmation window appears asking if you want to execute the import.

**12** Press [Yes] in the confirmation window to execute the import, or [No] to cancel it.

If you pressed [Yes], the import begins and a window opens to show its progress.

**To cancel an import after it has started**

Press [Cancel] in the progress window, and press [OK] in the message box which appears to inform you that the import has been cancelled.

**File names after the import**

- When you import a file named “image001.TIF”, the file name becomes “image001”, and the file is treated as a video-side file.
- When you import file named “image007.TIF (a)”, the file name becomes “image007 (k)”, respectively, and the files are treated as key-side files.

## Importing DME Effects

**About DME unit IDs**

When there are two switchers and connected DME units on the same network, the unit IDs of DME units determine, as shown below, whether or not it is possible for the DME units to be import targets.

**Units with ID 1 or 3:** Can be import targets. However, the unit with ID 1 receives priority.

**Units with ID 2 or 4:** Cannot be import targets.

*Refer to the user’s guide or installation manual of your switcher for more information about unit IDs.*

Proceed as follows to import DME effects.

- 1 From the top menu, select File >Import >DME Effect.

The Import menu for DME effects appears.

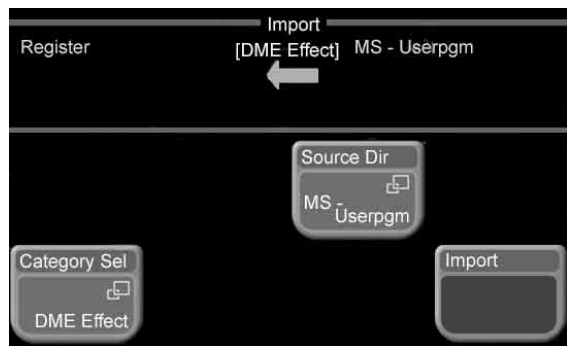

The media, directories, files, and registers used in the previous import operation appear in the status area.

- 2 As required, select the target media and directory of the operation.

*For details about the procedure, see steps 3 to 6 in “Common Operations – Selecting Categories, Media, and Directories” (page 191).*

- 3 Press [Import].

A confirmation window appears asking if you want to execute the import.

- 4 Press [Yes] in the confirmation window to execute the import, or [No] to cancel it.

If you pressed [Yes], the import begins and a window opens to show its progress. Note that all existing files in the import destination register are deleted before the import starts.

**Note**

User programmable DME data is not imported when you have selected EFF (the effect pattern number is 1001 or higher) as the transition type.

Operate after pressing the [MIX] button in the M/E transition control block to change the transition type.

**To cancel an import after it has started**

Press [Cancel] in the progress window, and press [OK] in the message box which appears to inform you that the import has been cancelled.

## Exporting Image Files

- 1 From the top menu, select File >Export.

The Export menu for frame memory appears.

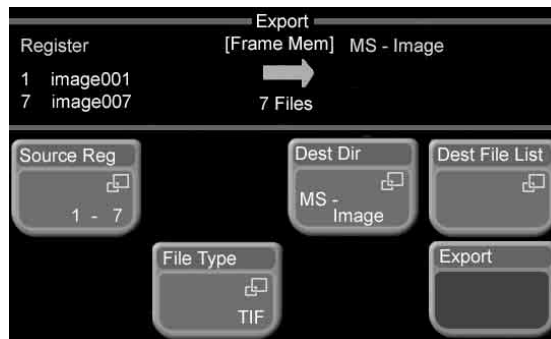

The media, directories, files, and registers used in the previous export operation appear in the status area.

- 2 As required, select the target media and directory of the operation.

*For details about the procedure, see steps 3 to 6 in “Common Operations – Selecting Categories, Media, and Directories” (page 191).*

- 3 In the File >Export >Frame Memory menu, press [Source Reg].

A register list appears in a popup window.

- 4 Do one of the following to select the export source registers.

- Press directly on the list.
- Use the arrow buttons to scroll the reverse video cursor.
- Turn the knobs

Knob	Description	Setting values
1 (Start Reg)	Number of first export source register	1 and upwards
2 (Number)	Number of export source registers	1 and upwards

**5** When you have selected the registers, press [OK].

The popup window closes.

**6** Press [File Type].

A popup window appears so that you can select the file format.

**7** Select the format into which you want to convert for the export, from among the following.

- BMP
- TIF (TIFF)
- TGA (Targa)

**8** Press [Export].

A confirmation window appears asking if you want to execute the export.

**9** Press [Yes] in the confirmation window to execute the export, or [No] to cancel it.

If you pressed [Yes], the export begins and a window opens to show its progress.

**To cancel an export after it has started**

Press [Cancel] in the progress window, and press [OK] in the message box which appears to inform you that the export has been cancelled.

**10** As required, press [Dest File List].

A list of files on the export destination media appears in a popup window.

Check to make sure that the image file in the registers you selected in step **4** have been exported.

“.SUB” is appended after the extension of key file names.

For example, if a file is named “image001.TIF”, the key file name is “image001.TIF.SUB”.

# Directory Operations

The following commands are available for working with media directories.

**New:** Create a new directory.

**Rename:** Rename a directory.

**Delete:** Delete a directory and the files in the directory.

**Lock:** Prevent editing of the directory (prevent overwriting and deletion of files in the directory, and prevent renaming and deletion of the directory).

## Creating Directories

**1** From the top menu, select File >Directory Manage.

The Directory Manage menu appears.



**2** Press [Media Sel].

A popup window appears so that you can select the media.

**3** Press the selection button for the desired media.

**4** Press [New].

The keyboard window appears.

See “Keyboard window” (page 40) in Chapter 3 for more information about keyboard window operations.

**5** Enter a name of up to eight characters, and then press [Enter].

A directory is created, and appears as the selected directory in the list.

**Note**

The following names cannot be used:

- CON, PRN, AUX, CLOCK\$, NUL, COM0, COM1, COM2, COM3, COM4, COM5, COM6, COM7, COM8, COM9
- LPT0, LPT1, LPT2, LPT3, LPT4, LPT5, LPT6, LPT7, LPT8, LPT9

## Renaming Directories

- 1** From the top menu, select File >Directory Manage.  
The Directory Manage menu appears.
- 2** Press [Media Sel].  
A popup window appears so that you can select the media.
- 3** Press the selection button for the desired media.
- 4** Do one of the following to select the directory.
  - Press directly on the list appearing in the status area.
  - Use the arrow buttons to scroll the reverse video cursor.
  - Turn the knob.

Knob	Description	Setting values
1 (No)	Directory selection	1 and upwards

- 5** Press [Rename].  
The keyboard window appears.  
  
*See “Keyboard window” (page 40) in Chapter 3 for more information about keyboard window operations.*
- 6** Enter a name of up to eight characters, and then press [Enter].  
The specified name appears in the list.

**Note**

The following names cannot be used:  
CON, PRN, AUX, CLOCK\$, NUL, COM0, COM1, COM2, COM3, COM4, COM5, COM6, COM7, COM8, COM9  
LPT0, LPT1, LPT2, LPT3, LPT4, LPT5, LPT6, LPT7, LPT8, LPT9

## Deleting Directories

- 1** Carry out steps **1** to **4** in “Renaming Directories” (the previous section).
- 2** Press [Delete].  
A message appears asking you to confirm the deletion.
- 3** Press [Yes] in the confirmation window to execute the deletion, or [No] to cancel it.  
  
If you pressed [Yes], the deletion is executed.  
If you pressed [No], you return to the Directory Manage menu.

## Disabling Editing in Directory Units (Locking Directories)

- 1** Carry out steps **1** to **4** in “Renaming Directories” (page 191).
- 2** Select [Lock], turning it on.  
The directory is locked, and a lock icon appears in the list.

**To unlock a directory**

Select the directory to unlock, and then press [Lock], turning it off.

## Common Operations – Selecting Categories, Media, and Directories

With a file operation menu displayed, proceed as follows.

- 1** To change the category selection, press [Category Sel].  
A popup window appears.
- 2** Select the desired category, and press [OK].  
The popup window closes.
- 3** To change the media selection from the current selection to the other type, press one of the following buttons, depending on the file operation.

File operation	Media to select	Button to press
Load	Load source media	[Source Dir]
Save	Save destination media	[Dest Dir]
Delete	Media where target file is saved	[Target Dir]
Rename	Media where target file is saved	[Target Dir]
Copy	Copy source media	[Source Dir]
	Copy destination media	[Dest Dir]
Import	Import source media	[Source Dir]
Export	Export destination media	[Dest Dir]

- A popup window opens.
- 4** Press the button for the desired media type.
- 5** Do one of the following to select the directory.

- Press directly on the list.
- Use the arrow buttons to scroll the reverse video cursor.
- Turn the knob.

Knob	Description	Setting values
1 (Directory)	Directory selection	1 and upwards

**6** Press [OK].

The popup window closes.

# External Media Support

## Formatting Media

You can format “Memory Stick” and media connected to the USB connector.

**1** From the top menu, select File >Directory Manage.

The Directory Manage menu appears.



**2** Press [Media Sel].

A popup window appears for media selection.



**3** Press [Memory Stick] or [USB].

**4** Press [Format].

A confirmation message appears.

**5** Press [Yes].

This starts the formatting operation, and a window appears, showing the progress. When the operation is completed successfully, a completion message appears.

Press [OK] to close the window.

# External Device Operations

Chapter

# 8

## Control From Editing Systems

### Overview

You can control the MFS-2000 system from an external editing system by using 9-pin serial control signals and GPI signals.

*Refer to the documentation of your editing system for more information about operations on the editing system.*

### Controllable Functions

#### When using 9-pin serial control signals

Following is a list of the functions which can be controlled via the EDITOR connector on the rear panel of the processor.

- Signal selection
- Specification of effect pattern numbers
- Specification of transition directions (normal or reverse)
- Specification of transition rates
- Execution of auto transitions
- Saving snapshots (store) and recalling snapshots

#### When using GPI signals

Following is a list of the main functions which can be controlled via the GPI connector on the rear panel of the processor.

- Auto transitions
- Cuts
- Key mix transition
- Key on and off

### Preparations

The following preparations must be made to control the MFS-2000 system from an external editing system.

#### Preparations on the MFS-2000 side

##### To use 9-pin serial control signals

Enable the switcher editor mode by doing one of the following.

- Press the [EDIT] button in the ENABLE/UTILITY operation button row on the control panel, turning it on.
- Set with a menu.

To set with a menu, proceed as follows.

- 1 From the top menu, select Misc >Enable >Enable/Safe Title.

The Enable/Safe Title menu appears.

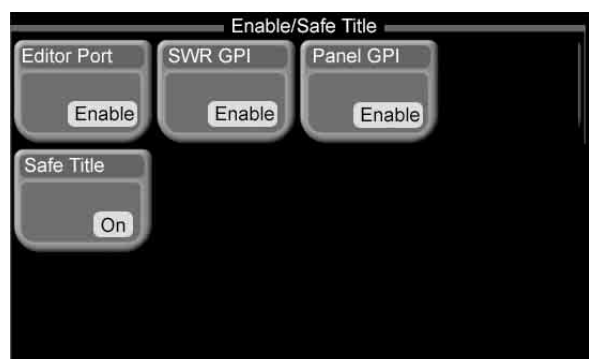

- 2 Press [Editor Port], and set it to Enable.

##### To use GPI signals

Make the following operations/settings.

- Press the [GPI] button in the ENABLE/UTILITY operation button row on the control panel, turning it on. Alternatively, press [SWR GPI] in the Enable/Safe Title menu, and set it to Enable.

- In the Setup/Diag >GPI >SWR GPI In menu, set the functions to be executed by GPI input signals. (See “GPI Input/Output Setup (GPI Menu)” (page 227).

**Note**

If you need to change the assignment of signals to cross-point buttons, do as follows.

- In the Xpt Assign menu (see page 206), make assignments so that button numbers and pair numbers are all the same.
- In the Video/Key Pair Assign menu (see page 207), change the signals assigned to pair numbers.

### Selecting the mode for turning off keys upon receiving the editor command

Selects the mode for turning off keys when an “All Stop” command is received from the editor.

- 1 In the Setup >Maintenance menu, press [Editor I/F].

The Editor I/F menu appears.

- 2 Select one of the following modes.

**All:** When an “All Stop” command is received, all keys for the selected regions are turned off.

**Specified:** When an “All Stop” command is received, among all the keys for the selected regions, only the keys specified by the editor are turned off.

**Note**

When an “All Stop” command is received in the process of a transition, the keys selected for the next transition are also turned off.

### Preparations on the editing system side

Set the GPI signal pulse width to 1 field (frame) or more depending on the video format.

## Operation From an Editing Keyboard

**Note**

The following operations are only possible when there is a valid license for the BZS-8050 Editing Control Software.

For more details, see “Entering an Installation Key (License Menu)” (page 210).

### Enabling and disabling operation from the editing keyboard

- 1 From the top menu, select Misc >Enable >Plug-In Editor.

The Plug-In Editor menu appears.

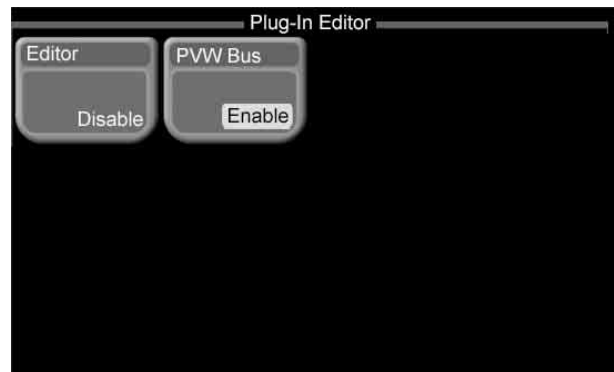

- 2 To enable operation from the editing keyboard, press [Editor] and set it to Enable. To disable, press once again to set it to [Disable].

#### To enable control of the preview bus only

When control from the editing keyboard is disabled (when [Editor] is set to “Disable”), to enable control of the preview bus only, in the Plug-In Editor menu, press [PVW Bus], setting it to “Enable”.

---

# Controlling External Devices

---

## Overview

On the MFS-2000 system, you can control the following external devices from the RS-422A 9-pin serial interface of a Device Control Unit (DCU).

- VTRs
- Disk recorders (supporting Sony Disk 9-pin protocol)
- Disk recorders (supporting the Video Disk Communications Protocol)
- Extended VTRs (Abekas A53 protocol)
- Audio mixers (control from editing keyboard only)

To control external devices, one of the following DCU systems is required.

**MKS-2700:** Six RS-422A ports (standard equipment).

**MKS-8700 (with optional MKS-8702 boards installed):**

Up to five boards may be installed, with each board providing six RS-422A ports (maximum 30 ports).

To control external devices, assign them to arbitrary RS-422A 9-pin serial interface ports.

*See page 239 for more information about how to make device assignments.*

---

## Manual VTR/Disk Recorder/ Extended VTR Operations

You can perform the following operations manually.

- Select VTRs, disk recorders, and Extended VTRs
- Play
- Stop
- Perform jog and shuttle mode search
- Set start points
- Cue up devices
- Record to VTRs and disk recorders

These manual operations are performed with the buttons of the utility control block or the Flexi Pad control block.

Note that it is prerequisite to assign the necessary utility commands to the DEVICE/UTILITY operation buttons in the utility control block or device control mode to a mode selection button in the Flexi Pad control block.

*See page 218 for more information about how to assign commands to buttons in the utility control block.*

*See page 225 for more information about how to assign device control mode to a mode selection button in the Flexi Pad control block.*

To play video from a disk recorder or Extended VTR, you need to read the files to play. To record to a disk recorder, you need to create the files to record.

*For details, see the procedure described in “Disk Recorder/Extended VTR File Operations” (page 197).*

## Selecting devices to control

Select devices to control by pressing the Device1 to Device6 selection buttons in the utility control block. You can select several devices. In this case, the device corresponding to the button which was pressed first becomes the reference device.

The button of the reference device lights in green. Manual operation buttons, light and go out according to the state of the reference device.

## Controlling the selected device

Although the following examples show the operations with the utility control block, you can make similar operations with the memory recall buttons of the Flexi Pad control block by pressing the [DEV CTRL] assigned button in the block.

*For details of the memory recall buttons of the Flexi Pad control block, see page 21.*

## Playing VTRs/disk recorders/Extended VTRs

Press the Play button, as assigned in the Utility menu.

During play, the button lights in amber.

To change the speed, set a variable speed.

*For more information about setting variable speeds, see the procedure described in “Checking VTR, Disk Recorder, and Extended VTR Information” (page 196).*

## Stopping VTRs/disk recorders/Extended VTRs

Press the Stop button, as assigned in the Utility menu.

The button lights in amber while the VTR/disk recorder/Extended VTR is stopped.

To stop all devices that can be selected with the Device1 to Device6 buttons, press the button with the All Stop assignment.

## Conducting jog and shuttle mode search

Select jog or shuttle mode by pressing the Jog or Shuttle button, as assigned in the Utility menu. Then control the direction and speed of search with the joystick in the Effect/Wipe control block.

Push the joystick to the right to search in the forward direction, and to the left to search in the reverse direction.

## Setting start points

Press the Start TC button, as assigned in the Utility menu.

The current timecode is set as the start point. The settable range is as follows, depending on the signal format.

00:00:00:00 to 23:59:59:xx (xx: frames per second minus 1 frame)

Start points can also be set from a menu. See “Setting start points” (page 197) for details about operation.

### Cueing up start points

Press the Cue Up button, as assigned in the Utility menu. While the reference device is cued up, the CUE button flashes in amber. When the cue up ends, the button changes to lit in green.

The All Stop button, as assigned in the Utility menu, also flashes in amber when any of the devices assigned to the Device1 to Device6 selection buttons is cued up, and changes to lit in green when ends for all devices.

### Recording to VTRs/disk recorders/Extended VTRs

With the Rec button held down, press the Play button (both buttons as assigned in the Utility menu).

During recording, the Rec button lights in red and the Play button lights in amber.

#### Notes

- Recording is not possible to Extended VTRs.
- Recording is not possible to VTRs and disk recorders unless they are set to Recorder.
- Recording start and end points cannot be set.
- To record to disk recorders using the Video Disk Communications Protocol, set the disk recorder to Recorder.

#### Notes about recording to disk recorders

- Recording is not possible unless a new file name is assigned.

For details, see “Creating new files (disk recorders only)” (page 198).

- The maximum recording time in one operation is 30 minutes.
- If recording is interrupted and restarted without changing the file name, recording results are saved in the same file from the point of interruption. If you want to record to a different file, create a new file (see page 198).

#### To stop recording

Press the Stop button or the All Stop button (both buttons as assigned in the Utility menu).

## Checking VTR, Disk Recorder, and Extended VTR Information

Use the Timecode Status menu to check VTR, disk recorder, and Extended VTR information.

To display the Timecode Status menu, select Misc>DDR/VTR>TC Status from the top menu. When the menu appears, the status, current timecode, start timecode, and

variable speed of each device (Device1 to Device6) appear in the status area.

You can change the settings of the start point timecode and the variable speed.

## Checking Device Status

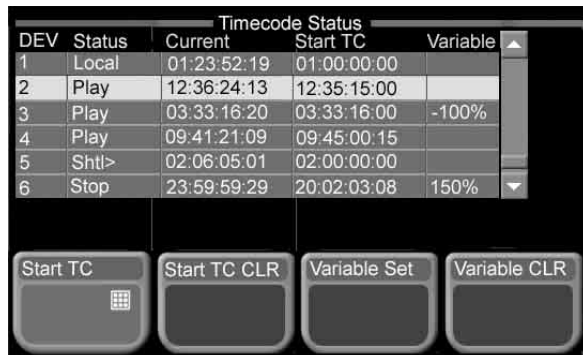

The following information is shown in the [Status] column.

Status display	When the Video Disk Communications Protocol is used	When other devices are used
XXXX	Not communicating, or communicating but the device type cannot be read.	Communications with the device are being carried out normally, but status information is not received.
Local	Port is not open.	The REMOTE/LOCAL switch of the device is set to LOCAL.
Tape Out	No file loaded.	<b>VTR:</b> No tape loaded. <b>Disk recorder:</b> No file loaded.
Rec <sup>a)</sup>	Recording	
Cue>	–	Cueing up in the forward direction.
Cue<	–	Cueing up in the reverse direction.
Eject	–	Ejecting cassette.
Play	Playing.	
Stop	Stopped.	Stopped in standby on mode.
Stb Off	–	Stopped in standby off mode.
FF	–	Fast forwarding.
Rewind	–	Rewinding.
Shtl>	–	Searching in the forward direction in shuttle mode.
Shtl<	–	Searching in the reverse direction in shuttle mode.
Var>	Searching in the forward direction in variable speed mode.	

Status display	When the Video Disk Communications Protocol is used	When other devices are used
Var<	Searching in the reverse direction in variable speed mode.	
Jog>	Searching in the forward direction in jog mode.	
Jog<	Searching in the reverse direction in jog mode.	
Still	–	Playing still image.

a) Displayed in red characters.

## Setting start points

**1** Do one of the following to select the device on which to set the start point.

- Press directly on the list in the status area.
- Use the arrow buttons to scroll the reverse video cursor.
- Turn the knob.

Knob	Description	Setting values
1 (DEV)	Device number	1 to 6

**2** Press [Start TC].

The timecode window opens.

**3** Input the desired start point timecode, then press [Enter].

This sets the start point.

### To delete a start point setting

Select the device selected in step **1** and press [Start TC CLR].

## Setting variable speeds

**1** Do one of the following to select the device on which to set the variable speed.

- Press directly on the list in the status area.
- Use the arrow buttons to scroll the reverse video cursor.
- Turn the knob.

Knob	Description	Setting values
1 (DEV)	Device number	1 to 6

**2** Turn the knob to set the variable speed.

Knob	Description	Setting values
2 (Variable)	Variable speed	–100 to +200

**3** Press [Variable Set].

The variable speed is set.

### To delete a variable speed setting

Select the device selected in step **1** and press [Variable CLR].

## Disk Recorder/Extended VTR File Operations

Internally, disk recorders and Extended VTRs manage recorded material in units of files.

When using disk recorders and Extended VTRs for playback and recording, you need to perform the following file operations.

**Loading file lists:** Before you can play a file from a disk recorder or Extended VTR, you need to display a list of the files stored on the device.

**Loading files:** With the file list visible, you need to select a file from the list to load.

**Creating files:** To record to a disk recorder, you need to create the file to record.

### Note

When using an MAV-555A/777 disk recorder to carry out file operations, the operation mode must be set to panel mode on the disk recorder side.

## Loading file lists

**1** From the top menu, select Misc >DDR/VTR >File List.

The File List menu appears. The upper part of the status area shows the device number of the currently selected device, and the currently loaded file. The lower part of the status area shows the names, data length (in timecode format), and dates of updating of files contained in the currently loaded file list.

No	File Name	Length	Date
1	Olympic_Flame_1	00:05:00:15	Jul.22.2004
2	Olympic_Flame_2	00:03:00:00	Jul.22.2004
3	Sacred_toroch_Relay_j_1	00:28:26:06	Jun.05.2004
4	Sacred_toroch_Relay_j_2	00:08:48:02	Jun.09.2004
5	Sacred_toroch_Relay_j_3	00:15:33:21	Jun.15.2004
6	Opening1	00:22:22:14	Aug.15.2004

Disk recorder used as player

### Notes

- File update dates are not displayed for disk recorders using the Video Disk Communications Protocol.
- File lengths and update dates are not displayed for Extended VTRs, and register numbers are shown in place of file names.

2 Turn the knob to select a player device.

Knob	Description	Setting values
1 (DEV)	Device number	1 to 6

**Note**

File lists cannot be loaded from disk recorders which are being used as recorders.

3 Press [List Update].

Loading of the file list starts, and a progress bar appears in a popup window. The popup window disappears when loading of the file list finishes successfully. An error message appears if an error occurs.

**To sort file lists**

1 Press [Sort].

A popup window appears.

2 Select the sort conditions.

**File No:** Sort by file number (smallest first).

**File Name:** Sort alphabetically by file name.

**Date:** Sort by file update date (newest first).

**Notes**

- File lists cannot be sorted by date when using the Video Disk Communications Protocol.
- File lists cannot be sorted when using an Extended VTR. (Extended VTR files are shown in register order (1 to 99).)

This sorts the file list in the selected order.

**File list sharing**

You can share loaded file lists across serial ports connected to the same disk recorder.

*For more information about how to share file lists, see “To share file lists” (page 241).*

**Loading files**

Proceed as follows to load a file from a file list.

1 From the top menu, select Misc >DDR/VTR >File List.

The File List menu appears.

2 Turn the knob to select the player device which has the file you want to load.

Knob	Description	Setting values
1 (DEV)	Device number	1 to 6

3 Do one of the following to select the file to load.

- Press directly on the list in the status area.
- Use the arrow buttons to scroll the reverse video cursor.
- Turn the knob.

Knob	Description	Setting values
2 (List No)	File number <sup>a)</sup>	1 and upwards
	Register number <sup>b)</sup>	0 and upwards

a)Disk recorder  
b)Extended VTR

4 Press [File Load].

The selected file is loaded, and its name appears at the top of the status area.

**Creating new files (disk recorders only)**

1 From the top menu, select Misc >DDR/VTR >File List.

The File List menu appears. The upper part of the status area shows the device number of the currently selected device, and the currently loaded file. The lower part of the status area shows the currently loaded file list.



Disk recorder set to Recorder

**Note**

File update dates are not displayed for disk recorders using the Video Disk Communications Protocol.

2 Turn the knob to select the device on which to create the new file.

Knob	Description	Setting values
1 (DEV)	Device number	1 to 6

**Note**

You will not be able to create a file if you select a disk recorder that is being used as a player.

- 3 Press [New File].

The keyboard window appears.

- 4 Enter a file name and press [Enter].

The maximum file name length is as follows.

**Disk recorder (Sony Disk 9-pin Protocol):** 16 characters

**Disk recorder (Video Disk Communications Protocol):** eight characters

The new file name appears at the top of the status area.

**When the loaded file is not a target for recording**

Press [File Unload].

The current file name at the top of the status area is cleared.

## Simple Connection to MKS-8080/8082 AUX Bus Remote Panel

You can connect the MKS-8080/8082 AUX Bus Remote Panel to enable remote control of the switcher's AUX buses.

To connect the MKS-8080/8082 to the control panel requires an HKSP-R80 Routing Switcher Controller Board or similar device constituting a primary station for an S-Bus data link, as well as various settings for connection. However, using a simple connection, the need for an S-Bus data link primary station is avoided, and direct connection to the MKS-8080/8082 is possible.

A simple connection is possible if the following conditions are met:

- There are no devices other than the MFS-2000 and MKS-8080/8082 connected on the S-Bus data link.
- There are no more than 16 MKS-8080/8082 units connected on the S-Bus data link.

*For settings on the MKS-8080/8082, refer to "Making the Settings With Buttons (Setup Function)" in the MKS-8080/8082 Operation Manual.*

Proceed as follows.

- 1 Carry out initialization of the MKS-8080/8082 settings. (This can be done on the MKS-8080/8082 separately.)
- 2 Set the MKS-8080/8082 station number in the range 2 to 17. (This can be done on the MKS-8080/8082 separately.)
- 3 Set the STATION ID switches S108 on the front panel of the FP-141 board to 001 (1 only is set to the OFF side).

This sets the MFS-2000 control panel as the S-Bus data link primary station.

- 4 Use the Setup/Diag >System >Initialize menu (*see page 214*) to reboot the system.

When the reboot finishes, connection to the MKS-8080/8082 is possible.

- 5 In the Setup/Diag >System Tally >S-Bus Assign menu (*see page 234*), set the position of the MFS-2000 system in the S-Bus space as follows.
  - Matrix size: Standard 136 × 138
  - Source, Destination, Level: 1

The MKS-8080/8082 operates in AUX bus mode, with settings set to the following factory defaults.

**C: SET SWITCHER ID (for AUX mode)**

This is set to 001, which is the station number of the MFS-2000 control panel.

**D: SET AUX DESTINATION/SOURCE (for AUX mode)**

The source is set to IN001 and following, and destination is set to OUT001 and following.

**H: SET PHANTOM TABLE (for Router mode)**

This is unset, since the unit does not operate in router mode.

**N: SET PANEL TABLE (for Router mode)**

The source is set to IN001 and following, and destination is set to OUT001 and following.

However, since the unit does not operate in router mode, these settings are not used.

**R: SET ROUTE**

Since when using the simple connection the switcher and router cannot be connected in cascade, no route setting is required, and this is unset.

**O: SET AVAILABLE SOURCE/DESTINATION**

The source and destination ranges are set so that the MFS-2000 inputs and outputs can be selected.

**Y: SET DISPLAY MODES**

The DISPLAY MODES/PANEL FUNCTION setting is set to NORMAL. The TALLY GROUP settings are all set to OFF.

**Z: SET PANEL STATUS**

The various settings are the same as the factory default settings.

*Refer to “Menu Operations” in the Operation Manual of the MKS-8080/8082 for the meaning of the above settings.*

## Basic Settings

### Format Settings (Format Menu)

Use the Format menu to set the signal format used in the switcher system, the input reference signal (HD system only), and the screen aspect ratio.

#### Note

Using an HD system requires the optional BZS-2000M.

#### Signal format

The signal format is indicated by a combination of the number of valid scan lines and the field frequency. The signal formats with which the switcher system can be used are as follows.

System	Valid scan lines	Field frequency
HD system	720p	50
		59.94
	1080i	50
		59.94
	1080PsF	23.976
		24
		25
		29.97
		50
SD system	480i	59.94
	576i	50

#### Input reference signal

When using an HD system, you can select the input reference signal from the following types.

**Black Burst:** SD system black burst

**Tri Sync:** HD system tri-level sync

#### Screen aspect ratio

You can set the screen aspect ratio to 4:3 or 16:9.

#### Note

After changing the signal format, input reference signal, or screen aspect ratio settings, be sure to save the new settings.

For details of saving settings, see “Saving Setup (Startup Mode Menu)” (page 208).

### Setting the signal format

- 1 From the top menu, select Setup/Diag >System >Format.

The Format menu appears. The status area shows the current settings (switcher settings) of the signal format, reference video signal, and screen aspect ratio.

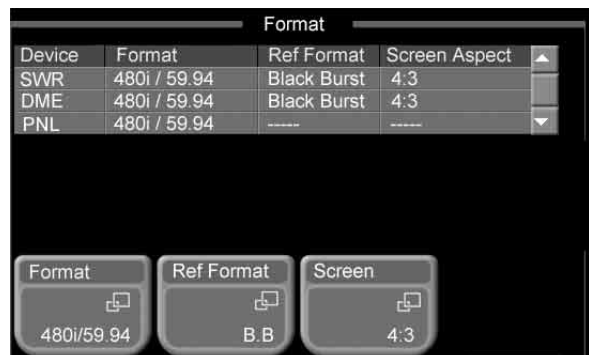

- 2 Press [Format].

A popup window appears, showing the signal formats that can be used in the system.

- 720P/50
- 720P/59.94
- 1080i/50
- 1080i/59.94
- 1080PsF/23.976
- 1080PsF/24
- 1080PsF/25
- 1080PsF/29.97
- 480i/59.94

- 576i/50

**3** Press directly on the indication for the signal format you want to set.

The popup window closes, and a confirmation message appears, prompting whether or not to change the signal format.

**4** Press [Yes] in the dialog box.

This changes the signal format setting, and resets the system.

**To cancel changing the signal format**  
Press [No] in the dialog box.

### Setting the input reference signal

**1** Carry out step **1** in the previous item, “Setting the signal format”.

**2** Press [Ref Format].

A popup window appears, showing the input reference signals that can be used in the system.

- Black Burst
- Tri Sync

**3** Press directly on the indication for input reference signal you want to use.

The popup window closes, and a confirmation message appears, prompting whether or not to change the input reference signal.

**4** Press [Yes] in the dialog box.

This changes the input reference signal.

**To cancel changing the input reference signal format**  
Press [No] in the dialog box.

### Setting the screen aspect ratio

**1** Carry out step **1** in the procedure “Setting the signal format” (*see page 201*).

**2** Press [Screen].

A popup window appears, showing the screen aspect ratios that can be used in the system.

- 4:3
- 16:9

**3** Press directly on the indication for the screen aspect ratio you want to use.

The popup window closes, and a confirmation message appears, prompting whether or not to change the screen aspect ratio.

**4** Press [Yes] in the dialog box.

This changes the screen aspect ratio.

**To cancel changing the screen aspect ratio**  
Press [No] in the dialog box.

## Setting the Startup Mode (Startup Mode Menu)

Use the Startup Mode menu to set the mode for when the devices in the switcher system are powered on. You can select resume mode or custom mode.

### Resume mode

This restores the system state at the time it was last powered off. You can only set this for the switcher processor and control panel.

### Custom mode

At power on, each device is initialized to settings stored in its own nonvolatile memory (user settings) or ROM (factory default settings). You can make separate settings for setup and initial status.

**Setup:** You can set the setup state used after powering on to User (user settings) or Factory (factory default settings).

**Initial status:** You can set the initial state (other than setup) of each device used after powering on to User (user settings) or Factory (factory default settings).

### Selecting resume mode for starting up after powering on

**1** From the top menu, select Setup/Diag >System >Startup Mode.

The Startup Mode menu appears. The status area shows the current settings.

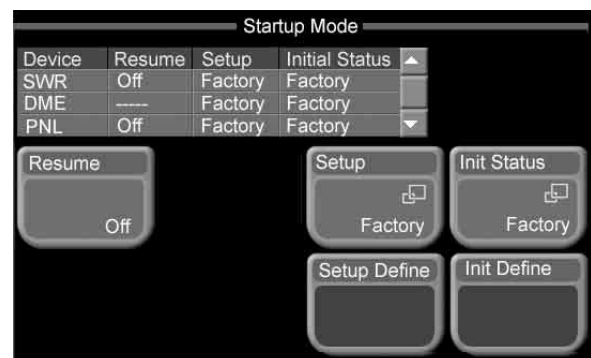

**2** Press [Resume].

The popup window in the Startup Mode menu closes, and a confirmation message appears, prompting whether or not to change the mode.

- 3 Press [Yes] in the dialog box.

This changes the mode.

**To cancel changing the mode**

Press [No] in the dialog box.

## Selecting custom mode for starting up after powering on

### To set setup to custom mode

- 1 Carry out step 1 in the previous item, “Selecting resume mode for starting up after powering on”.

- 2 If [Resume] is On, set it to Off.

- 3 Press [Setup].

A popup window appears.

- 4 Press [User] or [Factory].

The popup window closes, and a confirmation message appears, prompting whether or not to change the mode.

- 5 Press [Yes] in the dialog box.

This changes the mode.

**To cancel changing the mode**

Press [No] in the dialog box.

### To set initial status to custom mode

In step 2 of the above procedure, “To set setup to custom mode”, in place of [Setup], press [Init Status]. The remainder of the operation is the same.

## Output Signal Assignment (Output Assign Menu)

Assign output signals to each output port of the processor.

- 1 From the top menu, select Setup/Diag >Input/Output >Output Assign.

The Output Assign menu appears. The status area shows output port numbers and the output signals assigned to each port.

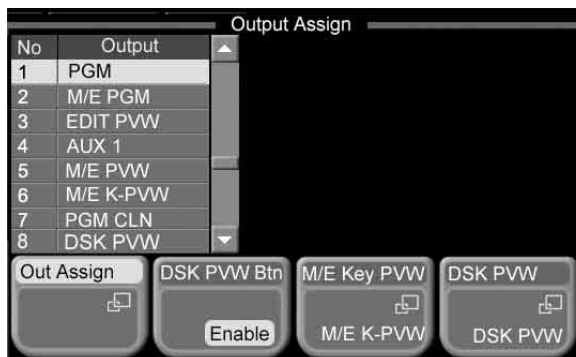

- 2 Select the output port number for which you want to make the setting.

- Press directly on the list in the status area.
- Use the arrow buttons to scroll the reverse video cursor.
- Turn the knob.

Knob	Description	Setting values
1 (No)	Output port number selection	1 to 8 <sup>a)</sup>

a) Values 5 to 8 are only valid when the MKS-2110M (option) is installed.

The selected output port number appears in reverse video.

- 3 Press [Out Assign].

A popup window appears. The assignable output signals are shown.



### Assignable output signals

- M/E PGM (M/E program signal)
- M/E PVW (M/E preview signal)
- M/E Key PVW (M/E key preview signal), M/E Key Out (M/E key output signal), or M/E PGM Clean (M/E program clean signal): The display varies depending on the setting of [M/E Key PVW] in the Output Assign menu.

- PGM (program signal): final output signal including the downstream key
- PST (preset signal)
- PGM Clean (program clean signal): final output signal excluding the downstream key
- DSK PVW (downstream key preview signal) or DSK Key Out (downstream key output signal): The display varies depending on the setting of [DSK PVW] in the Output Assign menu.
- AUX1 (auxiliary 1 signal) to AUX4
- EDIT PVW (edit preview signal)
- No Assign: no signal assigned.

**4** Select the output signal to be assigned to the output port selected in step **2**.

This makes the signal assignment. To the right of the output port number selected in the status area of the Output Assign menu is shown the name of the assigned output signal.

**Note**

Depending on the signal, the name shown in the popup window and the name shown in the status area of the Output Assign menu may be different.

Signal name shown in the popup window	Signal name shown in the status area of the Output Assign menu
M/E Key PVW	M/E K-PVW
M/E Key Out	M/E Key
M/E PGM Clean	M/E PGM CLN
PGM Clean	PGM CLN
DSK Key Out	DSK Key

### Switching M/E PVW or PST output to DSK PVW output

By pressing the DSK PVW button in the downstream key/fade to black control block, you can temporarily switch M/E PVW output (1 M/E panel) or PST output (1.5 M/E panel) to DSK PVW output.

**Notes**

- This function is not available when [DSK PVW Btn] is set to Disable. Press [DSK PVW Btn] to set it to Enable.
- This function is not available when DSK Key Out is selected instead of DSK PVW.

### Assigning Signals to Cross-Point Buttons (Operation Menu)

Each cross-point button in the M/E cross-point control block, PGM/PST cross-point control block (using a 1.5 M/E panel or 1.5 M/E wide panel), and AUX bus control block has two numbers. Select which of these numbers is

valid by toggling the dedicated [SHIFT] buttons above cross-point button rows on or off.

**Note**

The dedicated [SHIFT] button does not light and does not function when you are using the rightmost buttons in the cross-point button rows (the 12th or 20th buttons) as [SHIFT] buttons.

*For more information about how to use the rightmost buttons as [SHIFT] buttons, see “To use the rightmost buttons in cross-point button rows as [SHIFT] buttons (shift mode selection)” (page 206).*

### Button numbers of cross-point buttons

In the M/E cross-point control block, PGM/PST cross-point control block (using a 1.5 M/E panel or 1.5 M/E wide panel), and AUX bus control block, the button numbers of the cross-point buttons are as shown in the following figure.

For the cross-point buttons in all control blocks, the same signal is assigned to the same button number. The numbers of all of these buttons differ depending on whether the dedicated [SHIFT] button is on or off. The numbers also differ depending on whether the rightmost buttons in cross-point button rows are being used as [SHIFT] button (shift mode). See page 206 for more information about shift mode.

**Cross-point button numbers in the M/E cross-point control block**

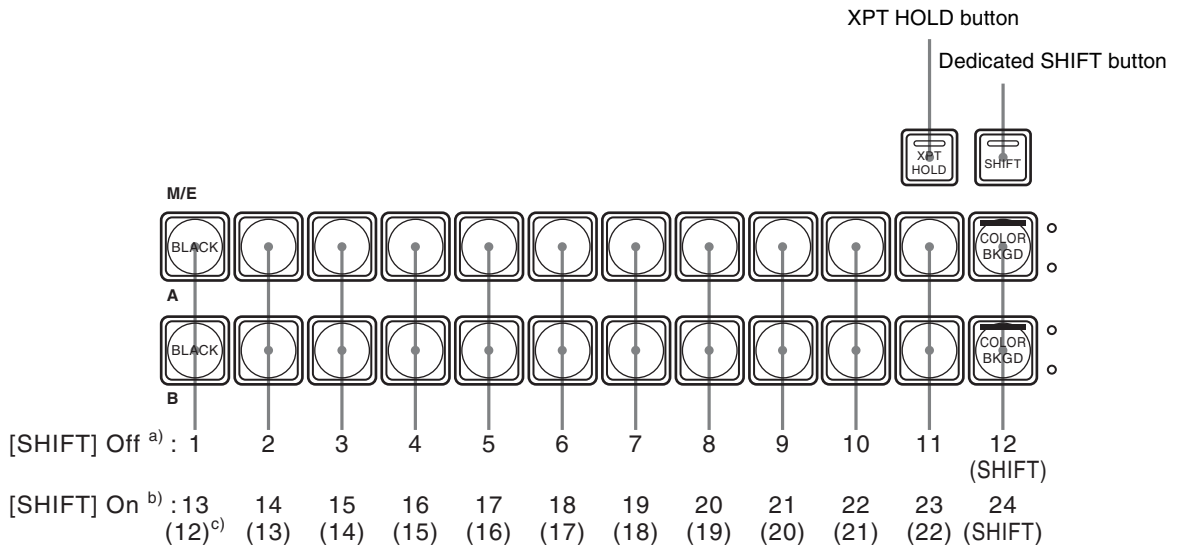

- a) For a 1.5 M/E wide panel: 1 to 20
- b) For a 1.5 M/E wide panel: 21 to 40
- c) The numbers in parentheses are the button numbers when shift mode is on (set to something other than Off).

**Cross-point button numbers in the PGM/PST cross-point control block  
(For a 1.5 M/E panel or 1.5 M/E wide panel. See figure below for 1.5 M/E panel.)**

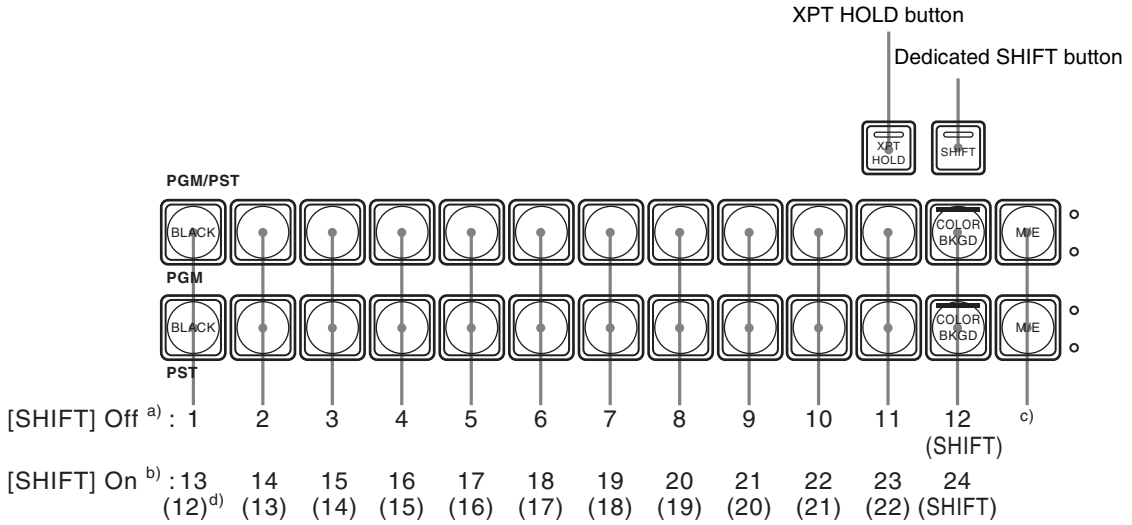

- a) For a 1.5 M/E wide panel, button numbers: 1 to 20
- b) For a 1.5 M/E wide panel, button numbers: 21 to 40
- c) The signal assignment to these buttons cannot be changed.
- d) The numbers in parentheses are the button numbers when shift mode is on (set to something other than Off).

**Cross-point button numbers in the AUX bus control block**

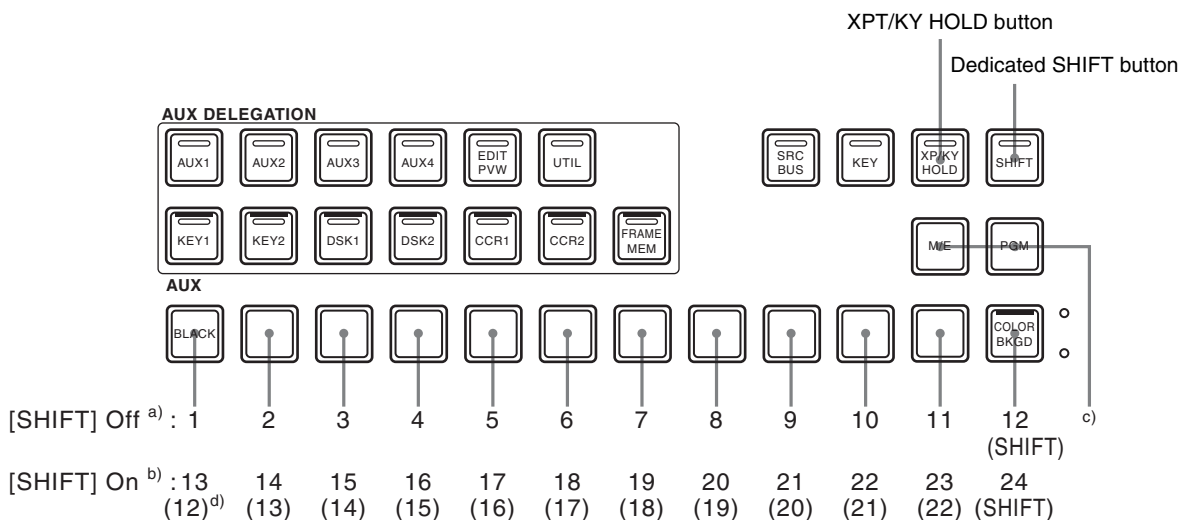

- a) For a 1.5 M/E wide panel, button numbers: 1 to 20
- b) For a 1.5 M/E wide panel, button numbers: 21 to 40
- c) The signal assignment to these buttons cannot be changed.
- d) The numbers in parentheses are the button numbers when shift mode is on (set to something other than Off).

**To use the rightmost buttons in cross-point button rows as [SHIFT] buttons (shift mode selection)**

By a XPT Assign menu setting, you can use the rightmost buttons on cross-point button rows (the 12th buttons on 1M/E or 1.5M/E panels, or the 20th buttons on 1.5M/E wide panels) as [SHIFT] buttons, which switch between cross-point button numbers.

In the XPT Assign menu, press [Shift Mode] to display a popup window, and select a setting other than Off.

**Hold:** Shift-side cross-point buttons are enabled as long as the rightmost button is held down.

**Lock:** Shift-side cross-point buttons are enabled as long as the rightmost button is on.

**Off:** Do not use the rightmost buttons as [SHIFT] buttons.

**Note**

The dedicated [SHIFT] button above the cross-point button rows is disabled when you select a setting other than Off.

**To set the cross-point button shift operation**

You can set the operation of the [SHIFT] buttons in the M/E, PGM/PST, and AUX bus blocks.

In the XPT Assign menu, press [Shift Button] to open a popup window, and select one of the following.

**Hold:** While this button is held down, the shift side buttons are enabled.

**Lock:** Pressing this button toggles it on and off. When the button is on, the shift side buttons are enabled.

**Off:** No effect.

**Signals assigned to cross-point buttons**

You can assign two signals, the video signal and key signal, as a pair to each cross-point button. With this unit you can register a maximum of 40 pairs of video and key signals. For each pair the assigned number is referred to as a pair number. The signal assignment to cross-point buttons is done by assigning pair numbers to cross-point button numbers.

*For the operation of combining a video signal and key signal, see “Creating a pair from a video signal and key signal” (page 207).*

**Assigning signals to cross-point buttons**

To carry out the assignment of a video signal and key signal pair to a cross-point button, use the Xpt Assign menu.

- 1 From the top menu, select Setup/Diag >Operation >Xpt Assign.

The Xpt Assign menu appears.

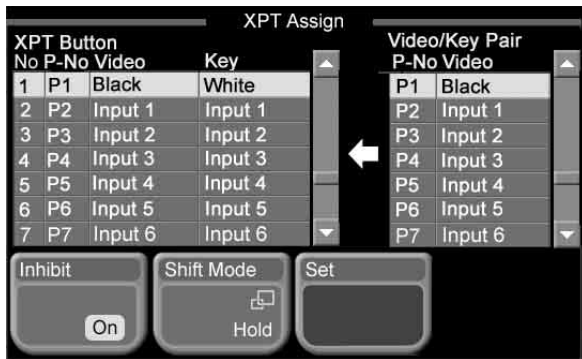

The “XPT Button” (cross-point button) list appears at the left of the status area. This list includes the following items.

- No:** cross-point button number
- P-No:** video signal and key signal pair number
- Video:** video signal name (source name)
- Key:** key signal name (source name)

The “Video/Key Pair” list appears at the right of the status area. This list includes the following items.

- P-No:** video signal and key signal pair number
- Video:** video signal name (source name) being one of the pair

**2** Using any of the following methods, select the cross-point button number to which you want to assign the signal.

- Press a cross-point button in the AUX bus control block.
- Press directly on the “XPT Button” list in the status area.
- Use the arrow buttons to scroll the reverse video cursor.
- Turn the knob.

Knob	Description	Setting values
1 (Button No)	Cross-point button selection	1 to 24 <sup>a)</sup> 1 to 40 <sup>b)</sup>

a) For 1 M/E panel and 1.5M/E panel  
b) For 1.5 M/E wide panel

The selected number appears in reverse video.

**3** Using any of the following methods, select the pair number for the video signal and key signal you want to assign to the selected cross-point button number.

- Press directly on the “Video/Key Pair” list in the status area.
- Use the arrow buttons to scroll the reverse video cursor.
- Turn the knobs.

Knob	Description	Setting values
4 (Pair No)	Pair number selection	P1 to P40

**4** Press [Set] in the button area.

### To disable any cross-point button

You can disable a cross-point button to which a signal is assigned so that pressing it does not select the signal. In step 2, select the desired button number, and press [Inhibit], turning it on.

### Creating a pair from a video signal and key signal

To create a pair from a video signal and key signal to be assigned to a cross-point button, use the Video/Key Pair Assign menu.

**1** From the top menu, select Setup/Diag >Operation >V/K Pain Assign.

The Video/Key Pair Assign menu appears.

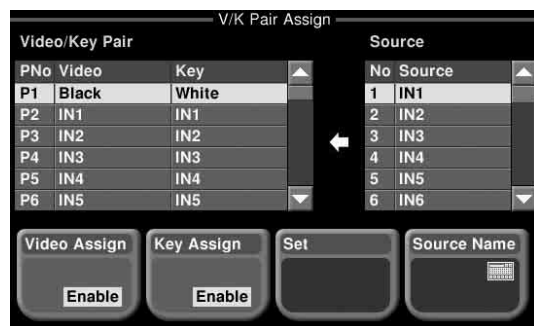

The “Video/Key Pair” list appears at the left of the status area. This list includes the following items.

- P-No:** video signal and key signal pair number
- Video:** video signal name (source name)
- Key:** key signal name (source name)

The “Source” list appears at the right of the status area. This list includes the following items.

- No:** source signal number
- Source:** source signal name

**2** Using any of the following methods, select the pair number you want to create (or combination you want to change).

- Press directly on the “Video/Key Pair” list in the status area.
- Use the arrow buttons to scroll the reverse video cursor.
- Turn the knobs.

Knob	Description	Setting values
1 (Pair No)	Pair number selection	P1 to P40

The selected pair number appears in reverse video.

- 3** To set the video signal for the selected pair, press [Video Assign] in the button area, setting it to “Enable”.
- 4** Using any of the following methods, select the source number to be assigned as the video signal.
  - Press directly on the “Source” list in the status area.
  - Use the arrow buttons to scroll the reverse video cursor.
  - Turn the knobs to make the setting.

Knob	Description	Setting values
4 (Source No)	Source number selection	1 to 33

The selected source number appears in reverse video.

- 5** Press [Set] in the button area.  
In the “Video” column of the “Video/Key Pair” list, the selected source name changes to the source name selected in step **4**.
- 6** To set the key signal for the selected pair, press [Key Assign] in the button area, setting it to “Enable”.
- 7** With the same operation as in step **4**, select the source number to be assigned as the key signal.
- 8** Press [Set] in the button area.  
In the “Key” column of the “Video/Key Pair” list, the selected source name changes to the source name selected in step **5**.

## To rename source signals

For the source signal names displayed on MKS-8082 and similar AUX bus remote panels, the default is “IN 16” and so on, but you can change the names as follows.

- 1** From the top menu, select Setup/Diag >Operation >V/K Pair Assign.  
The Video/Key Pair Assign menu appears.
- 2** Using any of the following methods, select the number of the source whose name is to be changed.
  - Press directly on the list in the status area.
  - Use the arrow buttons to scroll the reverse video cursor.
  - Turn the knob.

Knob	Description	Setting values
4 (Source No)	Source number setting	1 to 33

The selected source number appears in reverse video.

- 3** Press [Source Name].  
A keyboard window appears.
- 4** Enter the new source name (maximum 16 characters), and press [Enter].

### Note

The following characters cannot be used in a source name:

space \ / : , (comma) ; \* ? “ < > . (period) |

## Saving Setup (Startup Mode Menu)

Using the Startup Mode menu, you save the setup state of the devices constituting the switcher system and the initial status after powering on in the nonvolatile memory of each device.

### Saving the setup state

- 1** From the top menu, select Setup/Diag >System >Startup Mode.

The Startup Mode menu appears. The status area shows the current settings (*see page 202*)

- 2** Press [Setup Define].

A confirmation message appears, prompting whether or not to save the current setup state.

- 3** Press [Yes] in the dialog box.

This saves the state.

#### To cancel saving

Press [No] in the dialog box.

### Saving the initial status

- 1** Carry out step **1** in the procedure “Saving the setup state” (*previous section*).

- 2** Press [Init Define].

A confirmation message appears, prompting whether or not to save the current state of the devices as the initial status.

- 3** Press [Yes] in the dialog box.

This saves the state.

#### To cancel saving

Press [No] in the dialog box.

# Installing Software

This section describes how to install the software constituting the MFS-2000 system.

To install software, use the Info/Install menu. In the Info/Install menu, you can check the software version, or enter an installation key for each device.

## Displaying Version Information (Version Information Menu)

To check the version of the application software (referred to as “applications”) currently installed in the devices constituting the MFS-2000 system, use the Version Information menu.

To display the Version Information menu, from the top menu, select Setup/Diag >Info/Install >Version Info.

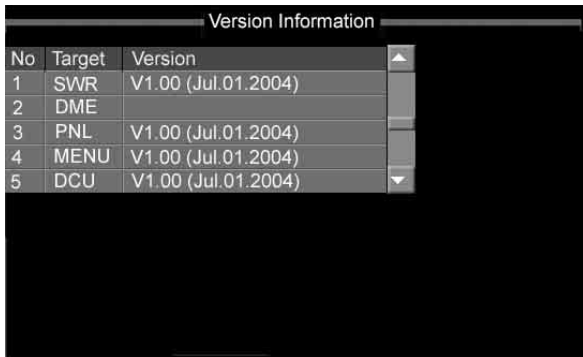

The status area shows abbreviations for the applications and the version numbers.

If there are no communications with an application in the menu, the application box is grayed out. If the version information is not available, the [Version] box is left blank.

### Abbreviations for applications

Abbreviation	Name
SWR	Switcher
DME	DME
PNL	Control panel
MENU	Menu
DCU	DCU

### Version information display

The version information is shown as follows.

V + version number + (Date)

E.g. V1.00 (Jul.01.2004)

**Version number:** V1.00

**Last updated:** July 1, 2004

## Displaying Detail Information (Detail Information Menu)

To check the detail information for an application shown in the Version Information menu, use the Detail Information menu.

To display the Detail Information menu, from the top menu, select Setup/Diag >Info/Install >Detail Info.

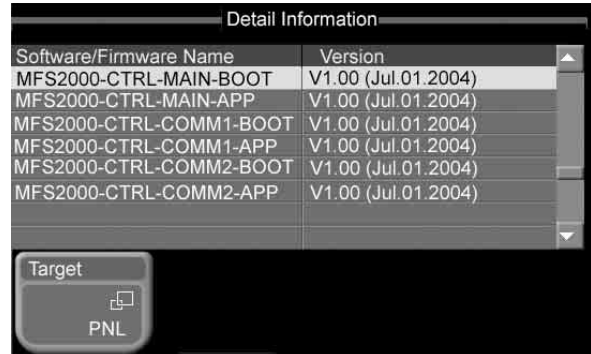

The abbreviation for the currently selected application appears on the [Target] button. The status area shows the name and version of the software/firmware constituting the currently selected application.

### Note

No detail information is shown for applications not communicating with the menu application and applications for which version information was not available.

### To change the application for which detail information is displayed

Press the [Target] button.

When the popup window appears, press the button for the application for which you want to view the detail information.

The button names are the same as the application abbreviations (see “Abbreviations for applications”).

## Manually Installing Software (Manual Install Menu)

To install only the required software/firmware manually, use the Manual Install menu. Insert a “Memory Stick” on which the software has already been written.

Alternatively, you can also use a USB storage device instead of a “Memory Stick”.

### Note

Install the DCU software separately from other software.

For details of software installation, refer to “Installing Software” in the Appendix (separate document).

- From the top menu, select Setup/Diag >Info/Install >Manual Install.

The Manual Install menu appears.

- Press [Refresh].

This loads the data from the “Memory Stick”, and the status area shows the abbreviation for each application, and the version, name, and install settings ([On]/[Off]) for the software/firmware constituting the application. If there are no communications with an application in the menu, the application box is grayed out.

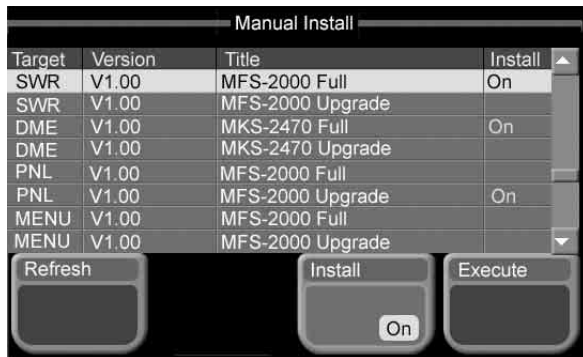

### If there is no data for an application to be installed in the “Memory Stick”

A dialog box appears.

Press [OK] to close the dialog box.

- Select the software/firmware.

- Press directly on the list in the status area.
- Use the arrow buttons to scroll the reverse video cursor.
- Turn the knob.

Knob	Setting	Values
1 (No)	Software/firmware selection	1 and upwards <sup>a)</sup>

a) The maximum value depends on application.

- Press [Install], turning it on, to install the software/firmware selected in step 3, or turning it off, not to install.

- Repeat steps 3 and 4.

- Press [Execute].

A confirmation message appears, prompting whether or not to carry out the installation.

- Press [Yes] in the dialog box.

This installs the software/firmware for which [On] is set.

### Note

Never power off during the installation. If you power off during the installation, the particular device may not be able to be restarted.

### To cancel the installation

Press [No] in the dialog box.

If you have pressed [Yes] to begin the installation, press [Cancel] in the progress bar.

### If an error occurs

A message appears, indicating what the error is.

Check the message, and press [OK] to close the message dialog box.

When the installation finishes, the indication in the [Install] column changes as follows.

**If the installation completes normally:** [OK] appears.

**If an error occurred:** [Error] appears.

## Entering an Installation Key (License Menu)

To use software options (referred to as “options”), installation keys are required. An installation key is a password (16 alphanumeric characters) issued for each option of each application. In the MFS-2000 system, installation keys are issued for the following options.

Application	Model number	Product name
SWR (switcher)	BZS-2000M	Switcher Upgrade Software (Multi)
	BZS-2440M	Frame Memory Upgrade Software (Multi)
DME	BZS-2470M	DME Upgrade Software (Multi)
PNL (control panel)	BZS-8050	Editing Control Software

To activate an option you want to use, you need to enter the installation key in the License menu.

To purchase an installation key requires the device ID (string of up to 17 alphanumeric characters). You can check the device ID in the License menu.

*For details of purchasing an installation key, contact your Sony sales representative.*

## Checking the unique device ID

- From the top menu, select Setup/Diag >Info/Install >License.

The License menu appears.

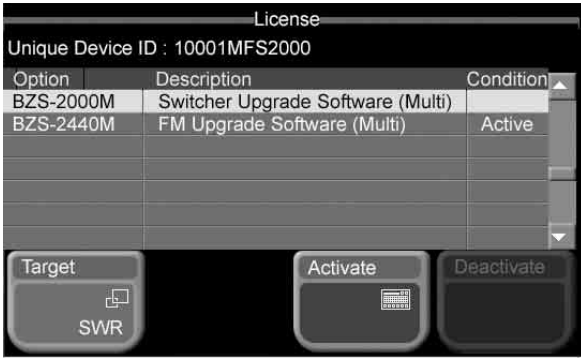

The abbreviation for the currently selected application appears on the [Target] button. The status area shows the device ID (Unique Device ID) for the currently selected application, and the model number, product name, and current state ([Active] or blank) of each of the options available. Unsupported option columns are grayed out.

### To change the application for which device ID and option information is displayed

Press [Target].

When the popup window appears, press the button for the application for which you want to view the information. The button names are the same as the application abbreviations (see “Abbreviations for applications” (page 209)).

### Entering an installation key to activate an option

- 1 Referring to the previous item “Checking the device ID”, display the License menu for the application for which you want to activate an option.
- 2 Select the option you want to use.

- Press directly on the list in the status area.
- Use the arrow buttons to scroll the reverse video cursor.
- Turn the knob.

Knob	Description	Setting values
1 (No)	Selection of option you want to use	1 and upwards <sup>a)</sup>

a) The maximum value depends on application.

- 3 Press [Activate].

A keyboard window appears.

- 4 Enter the installation key.

**If the installation key is correct:** a message appears, indicating that the option will be activated by carrying out a restart. Press [OK] in the dialog box, and proceed to step 5.

**If the installation key is incorrect:** a message appears, indicating that the installation key is incorrect. Press [OK] in the dialog box, go back to step 3, and re-enter the installation key.

- 5 Using either of the following methods, restart the system.

- In the Setup/Diag >System >Initialize menu, press [Reset].
- Exit the menu system, power the control panel off and then power it on again.

#### Note

Be sure to exit the menu system before powering the control panel off. (On how to exit the menu system, see “Exiting the Menu System” (page 47).)

After the restart, when you display the License menu, for the activated option, the [Condition] column shows [Active].

### To deactivate an option

- 1 Referring to steps 1 and 2 of “Entering an installation key to activate an option”, select the option you want to deactivate.

- 2 Press [Deactivate].

A confirmation message appears, prompting whether to deactivate the option.

- 3 Press [Yes] in the dialog box.

A message appears, indicating that after a restart the option will be deactivated.

#### To cancel deactivating the option

Press [No] in the dialog box.

- 4 Press [OK] in the dialog box, restart the system.

After the restart, when you display the License menu, for the deactivated option, the [Condition] column is blank.

# Other Settings

## Setting the Date and Time (Date/Time Menu)

Use the Date/Time menu to set the date and time used by the system.

- 1 From the top menu, select Setup/Diag >Maintenance >Date/Time.

The Date/Time menu appears. The status area shows the current date and time in the [Current] line, and the date and time to set in the [Set] line. Immediately after the menu appears, both lines contain the same date and time.



- 2 Press [Date].
- 3 Turn the knobs to change the date in the [Set] line.

Knob	Description	Setting values
1 (Month)	Month	1 to 12
2 (Day)	Day	1 to 31
3 (Year)	Year	2004 to 2037

- 4 Press [Time].
- 5 Turn the knobs to change the time in the [Set] line.

Knob	Description	Setting values
1 (Hour)	Hour	0 to 23
2 (Min)	Minute	0 to 59
3 (Sec)	Second	0 to 59

- 6 Press [Set].

The date and time in the [Set] line appear in the [Current] line.

## Panel Maintenance (Panel Menu)

Use the Panel menu to make the following settings related to the control panel.

- Brightness of LCD backlights
- Screen saver
- Beep on and off
- Touch panel calibration
- Hard disk formatting (only after a failure)

- 1 From the top menu, select Setup/Diag >Maintenance >Panel.

The Panel menu appears. The status area shows the current settings of each item (except for calibration and HDD format).

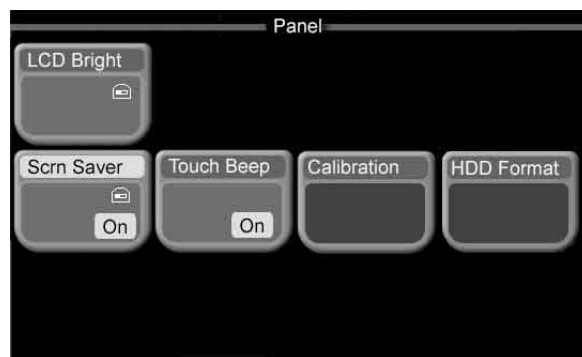

- 2 Press the button corresponding to the item you want to set, and set as described in the following sections.

**LCD Bright:** Brightness of the LCD buttons in the Flexi Pad control block

**Scrn Saver:** Screen saver on and off

**Touch Beep:** On and off of beep sounds for touch panel menu operations

**Calibration:** Calibration of touch panel

**HDD Format:** Initialization of hard disk (only after failure)

### To adjust the brightness of LCDs

Set by turning knob 1.

Knob	Description	Setting values
1 (Bright)	Brightness.	1 to 5

### To make screen saver settings

Press [Scrn Saver], turning it on or off, to turn the screen saver on and off.

When the screen saver is on, turn knob 1 to set the time until it activates.

Knob	Description	Setting values
1 (Wait)	Time (minutes) until screen saver activates.	1 to 300

### To turn beep sounds on and off

Press [Touch Beep], turning it on or off.

### To calibrate the touch panel

If touches on the touch panel do not select the desired menu items, you can use the following procedure to calibrate the touch panel.

- 1 Press [Calibration].

The following message appears.

“To perform calibration, please touch the center of each plus sign”.

- 2 Press [Yes].

- 3 Press the center of the [+] mark on the screen.

The [+] mark that you pressed disappears, and another [+] mark appears on the diagonally opposite side.

- 4 Press the center of the [+] mark.

A confirmation message appears.

Press [Yes] in the message dialog to confirm the calibration. Press [No] to cancel the calibration and return to the Maintenance menu.

### To format the hard disk

Use [HDD Format] to format the hard disk. Do this only when one of the following errors has occurred.

Error display	Error description
Internal Error: Data HDD	Data on the internal hard disk is corrupt.
Internal Error: HDD Format	The internal hard disk is not formatted, or hard disk partitions cannot be recognized.

When you press [HDD Format], a confirmation message appears asking if you really want to format the hard disk. Press [Yes] in the message dialog to execute the format. Press [No] to cancel the format.

## System Adjustments (System Adjust Menu)

Use the System Adjust menu to carry out system phase adjustments, operation switching timing settings, illegal color adjustments, and FM data port settings.

### Adjusting the system phase

- 1 From the top menu, select Setup/Diag >System >System Adjust.

The System Adjust menu appears. The status area shows the current settings.

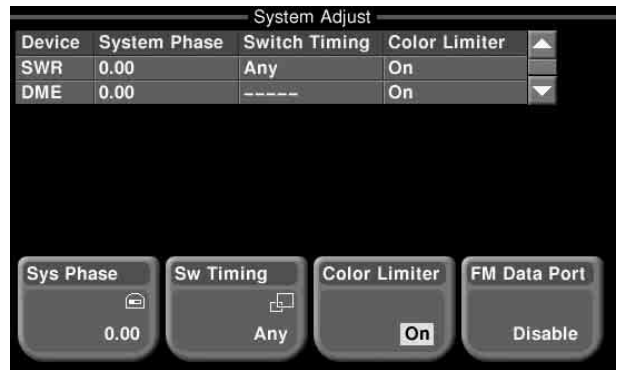

- 2 Press [Sys Phase].

- 3 Turn the knobs to adjust the phase.

Knob	Description	Setting values
1 (System Phase)	System phase setting	-32.00 to +96.00

### Setting the operation switching timing

- 1 Carry out step 1 in the previous item, “Adjusting the system phase”.

- 2 Press [Sw Timing].

A popup window appears.

- 3 Select one of the following.

**Any:** Switch on the earliest field that can be processed.

**Field 1:** Switch on field 1.

**Field 2:** Switch on field 2.

#### Note

When the signal format is 720P or 1080PsF, the switching timing is fixed on field 1.

### Setting the illegal color limiter

- 1 Carry out step 1 in the procedure “Adjusting the system phase”.

- 2 Press [Color Limiter], to switch the illegal color limiter on or off.

### Enabling the FM Data Port of the switcher

With the FM Data Port enabled, frame memory data can be transferred in a short time between the switcher and the control panels.

Note that only one data port can be used when the system has multiple clients of the data LAN.

In the System Adjust menu, press [FM Data Port], turning it “Enabled”. To disable the port, press [FM Data Port] again.

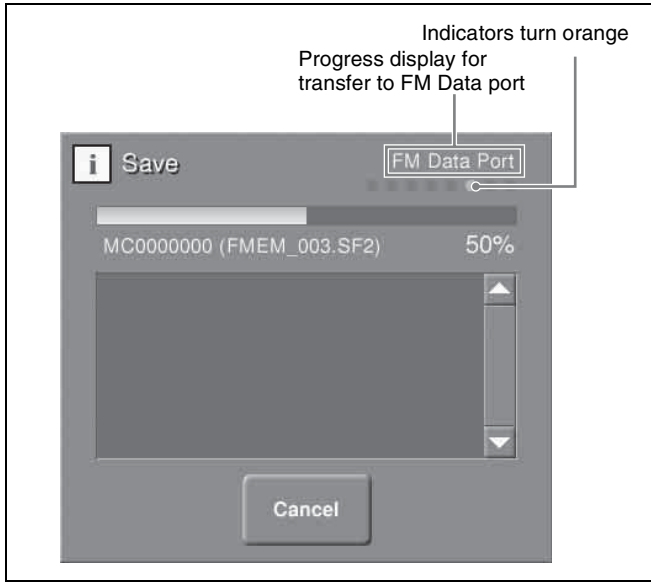

## System Reset and Memory Initialization (Initialize Menu)

Use the Initialize menu to carry out a system reset or memory initialization.

When you carry out a system reset, the system is restarted in the state set for power on (see page 202). Carrying out a memory initialization returns to the factory default settings.

### Resetting the whole system

- 1 From the top menu, select Setup/Diag >System >Initialize.

The Initialize menu appears.

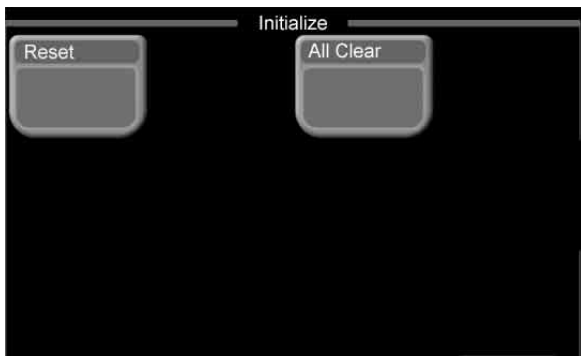

- 2 Press [Reset].

The popup window closes, and a confirmation message appears, prompting whether or not to reset.

- 3 Press [Yes] in the dialog box.

This resets the system.

#### To cancel the reset

Press [No] in the dialog box.

### Initializing memory

- 1 Carry out step 1 in the previous item, “Resetting the whole system”.

- 2 Press [All Clear].

The popup window closes, and a confirmation message appears, prompting whether or not to carry out the memory initialization.

- 3 Press [Yes] in the dialog box.

This initializes memory, and resets the system.

#### To cancel memory initialization

Press [No] in the dialog box.

## Input Signal Setup (Input/Output Menu)

Use the Input/Output menu to carry out setup relating to processor primary input signals.

You can make the following settings.

**Phase:** Adjust the phase of the primary input signals.

**Through mode:** For each primary input, select whether the through mode is on or off. The through mode is a mode in which the sync signal included in an output signal is not replaced by an internally generated sync signal, but is left unchanged.

**Video process:** Adjusts the input signal luminance and hue.

### Carrying out phase adjustments and through mode setting

- 1 From the top menu, select Setup/Diag >Input/Output >Input Adjust.

The Input Adjust menu appears. The status area shows the input number, signal phase, and through mode setting.

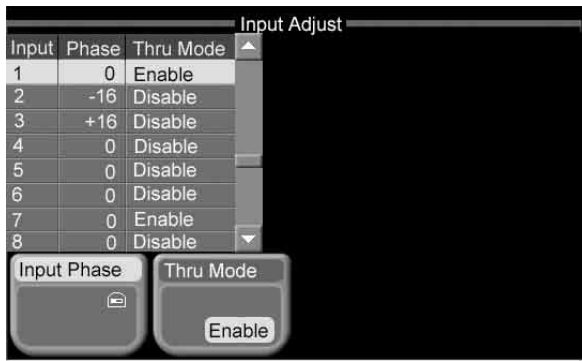

**2** Select the input number for which you want to make the setting.

- Press directly on the list in the status area.
- Use the arrow buttons to scroll the reverse video cursor.
- Turn the knob.

Knob	Description	Setting values
1 (Input)	Input number selection	1 to 16 <sup>a)</sup>

a) Values 9 to 16 are only valid when the MKS-2110M (option) is installed.

The selected input number appears in reverse video.

**3** To adjust the phase, press [Input Phase], and turn the knobs to adjust the parameters.

Knob	Description	Setting values
2 (Input Phase)	Phase	-16 to +16

**4** To carry out the through mode setting, press [Thru Mode], toggling it between Enable and Disable.

**Enable:** Enable the through mode.

**Disable:** Disable the through mode.

**Note**

To make through mode effective, it is also necessary to set output side through mode to “Enable” (see page 216).

## Making the video process setting

**1** From the top menu, select Setup/Diag >Input/Output >Video Process.

The Video Process menu appears. The status area shows the input numbers, and video processing adjustment values.



**2** Select the input number for which you want to make the setting.

- Press directly on the list in the status area.
- Use the arrow buttons to scroll the reverse video cursor.
- Turn the knob.

The parameter assignment to knob 1 is the same in parameter groups 1/2 and 2/2.

Knob	Description	Setting values
1 (Input)	Input number selection	1 to 16 <sup>a)</sup>

a) Values 9 to 16 are only valid when the MKS-2110M (option) is installed.

The selected input number appears in reverse video.

**3** Press [Video Proc], turning it on.

**4** Turn the knobs to adjust the parameters.

### Parameter group 1/2

Knob	Description	Setting values
2 (Video Gain)	Overall gain of the video signal	-200.00 to +200.00
3 (Y Gain)	Y signal gain	-200.00 to +200.00
4 (Black Level)	Black level	-7.31 to +109.59

### Parameter group 2/2

Knob	Description	Setting values
2 (Video Gain)	Overall gain of the video signal	-200.00 to +200.00
3 (C Gain)	Chrominance signal gain	-200.00 to +200.00
4 (Hue Delay)	Hue delay	-180.00 to +180.00

## Output Signal Setup (Input/Output Menu)

Use the Input/Output menu to carry out setup relating to output signals.

You can make the following settings.

**Output signal assignment:** Assign an output signal to each output port. (See “Output Signal Assignment (Output Assign Menu)” (page 203).)

**Video clip:** For each output port, adjust the output signal clip levels (White Clip, Dark Clip, Chroma Clip).

**Vertical blanking width:** For each output port, adjust the vertical blanking width of the output signal. The adjustment value indicates the position of the line up to which masking takes place, relative to the blanking width of field 1 of the video format.

**Through mode:** For each output port, set whether the through mode is on or off. The through mode is a mode in which the sync signal included in an output signal is not replaced by an internally generated sync signal, but is left unchanged.

**Crop:** When the screen aspect ratio in an HD system is 4:3, set how the output image is reduced to 4:3.

**Safe title:** Select safe title markers for each output port.

**Reference output:** Adjust the reference output phase with respect to the reference input phase, as a number of lines and a time.

## Video clip adjustment

- From the top menu, select Setup/Diag >Input/Output >Output Clip.

The Output Clip menu appears. The status area shows the output port numbers, and the output signal assigned to each port, and the white clip, dark clip, and chrominance clip values.

No	Output	White	Dark	Chroma
1	PGM	109.02	-6.85	113.17
2	M/E PGM	109.02	-6.85	113.17
3	EDIT PVW	109.02	-6.85	113.17
4	AUX 1	109.02	-6.85	113.17
5	M/E PVW	109.02	-6.85	113.17
6	M/E K-PVW	109.02	-6.85	113.17
7	PGM CLN	109.02	-6.85	113.17
8	DSK PVW	109.02	-6.85	113.17

- Select the output port number for which you want to make the setting.

- Press directly on the list in the status area.
- Use the arrow buttons to scroll the reverse video cursor.
- Turn the knob.

Knob	Description	Setting values
1 (No)	Output port number selection	1 to 8 <sup>a)</sup>

a) Values 5 to 8 are only valid when the MKS-2110M (option) is installed.

The selected output port number appears in reverse video.

- Press [Output Clip].
- Turn the knobs to adjust the parameters.

Knob	Description	Setting values
2 (White)	Luminance signal white clip value	90.00 to 109.02
3 (Dark)	Luminance signal dark clip value	-6.85 to +10.00
4 (Chroma)	Chrominance signal clip value	90.00 to 113.17

### To reset the settings to the default values

Press [Default]. All parameters, White, Dark, and Chroma for the output signal currently being set are returned to their default values.

## Making vertical blanking width and through mode settings

- From the top menu, select Setup/Diag >Input/Output >V Blank/Through.

The V Blank/Through menu appears. The status area shows the output port numbers, and for each port the assigned output signal, vertical blanking width, and through mode setting.

No	Output	V Blank Mask	Thru Mode
1	PGM	19	Enable
2	M/E PGM	19	Enable
3	EDIT PVW	19	Enable
4	AUX 1	19	Disable
5	M/E PVW	19	Enable
6	M/E K-PVW	19	Enable
7	PGM CLN	19	Enable
8	DSK PVW	19	Enable

- Select the output port number for which you want to make the setting.

- Press directly on the list in the status area.
- Use the arrow buttons to scroll the reverse video cursor.
- Turn the knob.

Knob	Description	Setting values
1 (No)	Output port number selection	1 to 8 <sup>a)</sup>

a) Values 5 to 8 are only valid when the MKS-2110M (option) is installed.

The selected output port number appears in reverse video.

- 3 Press [V Blank].
- 4 Turn the knobs to adjust the parameters.

Knob	Description	Setting values
2 (Mask End)	Last line of vertical blanking interval	10 to 19 <sup>a)</sup> 6 to 22 <sup>b)</sup> 7 to 20 <sup>c)</sup> 7 to 25 <sup>d)</sup>

- a) When signal format is 480i/59.94
- b) When signal format is 576i/50
- c) For any signal format with valid scan lines of 1080i or 1080PsF
- d) When signal format is 720p/50 or 720p/59.94

**To reset the settings to the default values**  
Press [Default].

- 5 To carry out the through mode setting, press [Thru Mode], toggling it between Enable and Disable.

**Enable:** Enable the through mode.  
**Disable:** Disable the through mode.

**Notes**

- The through mode setting can only be made for the following output signals.  
M/E PGM, PGM, PGM Clean, AUX1 to AUX4, and Edit PVW
- To make through mode effective, it is also necessary to set input side through mode to “Enable” (see page 215).

**In an HD system, to crop the image in 4:3 mode**

- 1 From the top menu, select Setup/Diag >Input/Output >Output Crop.

The Output Crop menu appears. The status area shows the output port numbers, and for each port the assigned output signal, and 4:3 crop mode setting.

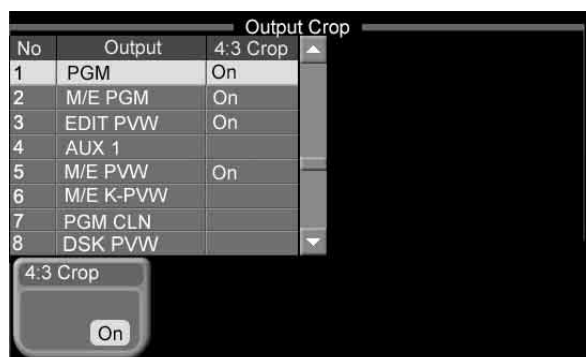

- 2 Select the output port number for which you want to make the setting.
  - Press directly on the list in the status area.
  - Use the arrow buttons to scroll the reverse video cursor.
  - Turn the knob.

Knob	Description	Setting values
1 (No)	Output port number selection	1 to 8 <sup>a)</sup>

a) Values 5 to 8 are only valid when the MKS-2110M (option) is installed.

The selected output port number appears in reverse video.

- 3 Press [4:3 Crop].

This toggles the 4:3 crop mode on and off, and the [4:3 Crop] column in the status area shows the setting as follows.

**Indication when enabled:** On  
**Indication when disabled:** blank

**Note**

When the HD system screen aspect ratio is set to 16:9 (see page 202) in the Setup/Diag >Format menu or when your system is set to an SD format (see page 201), it is not possible to enable the 4:3 crop mode.

**Setting the reference output**

- 1 From the top menu, select Setup/Diag >Input/Output >Ref Out.

The Reference Out menu appears. The status area shows the reference output phase parameters (Line, Time).

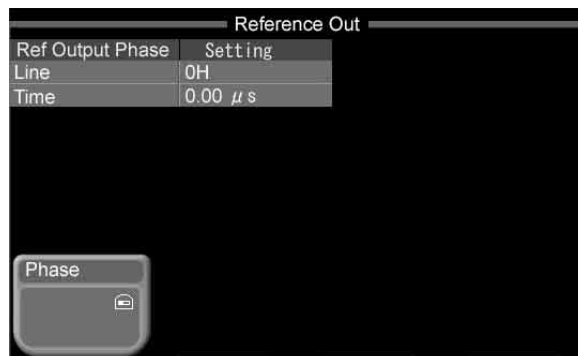

- 2 Press [Phase].
- 3 Turn the knobs to adjust the parameters.

Knob	Description	Setting values
1 (Line)	Number of lines	-90 to +90
2 (Time)	Time	-32.00 to +96.00

## Making safe title settings

This procedure allows you to set up safe title output. To actually execute safe title output, you need to turn on safe title output in the Enable/Safe Title menu.

For details about operation, see “Safe Title” (page 178).

- From the top menu, select Setup/Diag >Input/Output >Safe Title.

The Safe Title menu appears. The status area shows the output port numbers, the output signal assigned to each port, and the markers set for each port.



- Using any of the following methods, select the output port number for which you want to make the setting.

- Press directly on the list in the status area.
- Use the arrow buttons to scroll the reverse video cursor.
- Turn the knob.

Knob	Description	Setting values
1 (No)	Output port number selection	1 to 8 <sup>a)</sup>

a) Setting values 5 to 8 are valid only when the MKS-2110M (option) is installed.

The selected output port number appears in reverse video.

- Press the button for the marker that you want to set (multiple selections possible).

**Box1:** Box marker 1

**Box2:** Box marker 2 (adjustable luminance)

**Cross:** Cross marker

If you select Box1 or Box2, a popup window opens so that you can select the aspect ratio. You can also set the aspect ratio by turning the knobs. If you select Cross, the cross marker is turned on.

## To select the aspect ratio

In the popup window, press the button for the aspect ratio that you want.

- 16:9
- 14:9
- 4:3

## To set other marker parameters

Turn the knobs to adjust the following parameters.

- When Box1 was selected:

Knob	Description	Setting values
2 (Size)	Size of box	50.00 to 100.00

- When Box2 was selected:

Knob	Description	Setting values
2 (Size)	Size of box	50.00 to 100.00
3 (Luminance)	Luminance of displayed color	0.00 to 100.00

## Utility Settings (Utility Menu)

You can assign utility commands to the buttons in the utility control block.

## Assigning utility commands

- From the top menu, select Setup/Diag >Operation >Utility.

The Utility menu appears. The “Assign” list of currently assigned utility commands appears at the left of the status area. The “Utility Command” list of all assignable utility commands appears at the right of the status area.

The status area displays abbreviated utility command names. See the next section “Utility command list” for a list of these abbreviated names.



- Press [Block Sel].

A popup window appears.

- 3** Select the group of operation buttons to which you want to assign a utility command.

**Device/Utility:** DEVICE/UTILITY operation buttons

**Enable/Utility:** ENABLE/UTILITY operation buttons

- 4** In the “Assign” list, select the button to which you want to assign the command.

- Press directly on the list in the status area.
- Use the arrow buttons to scroll the reverse video cursor.
- Turn the knob.

Knob	Description	Setting values
1 (No)	Button number selection	1 to 9 <sup>a)</sup> 1 to 4 <sup>b)</sup>

a) When Device/Utility is selected

b) Enable/Utility is selected

- 5** In the “Utility Command” list, do any of the following to select the command to assign to the selected button.

- Press directly on the list in the status area.
- Use the arrow buttons to scroll the reverse video cursor.
- Turn the knobs.

Knob	Description	Setting values
3 (Command)	Utility command selection	1 and upwards
4 (GPI No) a)	GPI number selection	1 to 16

a) Knob 3 appears only when SWR GPI ? Test Fire is selected.

- 6** Press [Set].

**To clear a utility command assignment**

Select a button by performing step **4**, and press [Clear].

## Utility command list

The status area displays the following abbreviated names of utility commands.

Command name	Function of command button	Button state	
		Lit <sup>a)</sup>	Not lit
Editor Enbl	Enable and disable the switcher editor port.	Enable	Disable
SWR GPI Enbl	Enable and disable all switcher GPI input ports.		
Panel GPI Enbl	Enable and disable all control panel GPI input ports.		
Sys Manager Enbl <sup>b)</sup>	Enable and disable operation from System Manager.		
Plug-In Editor Enbl	Enable and disable operation from an editing keyboard.		
Safe Title	Switch between output (On) and no output (Off) of safe title markers.	On	Off
FM V Frame Freeze	Switch between frame-unit capture of video to frame memory (On) and no capture (Off).		
FM V Field Freeze	Switch between field-unit capture of video to frame memory (On) and no capture (Off).		
FM V Freeze Off	Switch between disable freeze capture of video to frame memory (On) and enable freeze capture (Off).		
FM K Frame Freeze	Switch between frame-unit capture of key to frame memory (On) and no capture (Off).		
FM K Field Freeze	Switch between field-unit capture of key to frame memory (On) and no capture (Off).		
FM K Freeze Off	Switch between disable freeze capture of key to frame memory (On) and enable freeze capture (Off).		
SWR GPI ? Test Fire <sup>c)</sup>	Execute test trigger output on the selected GPI output port.	Flashes during test fire execution	–
Device 1 to Device 6	Select devices to control. When several devices are selected, the button pressed first selects the reference device.	Selection (lights in green for reference device)	De-selection
FM1 V Clip to FM3 V Clip	Select frame memory clips to control.	Selection	De-selection
FM1 V & K Clip to FM3 V & K Clip	Select frame memory clips to control.	Selection	De-selection
Play	Execute play by the selected device, or when pressed together with the Rec button, execute recording by the selected device. Execute play of the selected frame memory clip.	Executing play or recording	Play or recording over or stopped
Stop	Stop play, recording, or cue up by the selected device and those operations of the selected frame memory clip.	Play, recording, or cue up is over or stopped	Executing play, recording, or cue up, or executing jog or shuttle search
All Stop	Stop play, recording, or cue up by all devices and those operations of the selected frame memory clip.	<b>Executing:</b> Flashes once <b>Cued up:</b> Flashes in amber <b>Cue up over:</b> Lights in green	–
Cue Up	Cue up the selected device. When several devices are selected, the button lights in green when the reference device finishes cue up. Cue up the selected frame memory clip.	<b>Executing:</b> Flashes <b>Execution over:</b> Lights in green	Stopped
Start TC	Set the timecode of the point where the button is pressed as the start timecode of the selected device or frame memory clip.	Flashes during execution (beep also output)	–

Command name	Function of command button	Button state	
		Lit <sup>a)</sup>	Not lit
Stop TC	Set the timecode of the point where the button is pressed as the stop timecode of the selected frame memory clip.	Flash during execution	–
Shuttle	Turn shuttle mode on or off.	On	Off
Jog	Turn jog mode on or off.		
Rec	When pressed together with the Play button, execute recording on the selected device.	Lights in red during execution.	Recording over or stopped
FM Loop	Set the frame memory clip loop playback.	On	Off
Mcro Only Set	Set macro attachment mode to Macro Only.	On	Off
Mcro AT with Rate	Save transition rate when registering a macro event, and apply it as the transition rate when executing the event (only when registering auto transition, key auto transition, or fade to black).		
Mcro AT with A/B	Save A/B Bus cross-point settings when registering a macro event, and apply them as A/B Bus cross-point settings when executing the event (only when registering auto transitions).		
Auto PVW	Turn auto preview on and off. When auto preview is on, Edit PVW output switches as follows. <b>Button with PVW Select M/E assignment is on:</b> If M/E PGM is on-air, switch Edit PVW output to M/E PVW output. If M/E PGM is not on-air, switch Edit PVW output to M/E PGM output. <b>Button with PVW Select PST assignment is on:</b> If M/E PGM is selected on both PGM bus and PST bus, switch Edit PVW output to M/E PVW output. If signal other than M/E PGM is selected on either PGM bus or PST bus, switch Edit PVW output to PST output.	On (lit in green)	Off
PVW Select M/E	Switch Edit PVW output to M/E PVW output. (Goes off automatically when other operation disables this command.)	On	Off
PVW Select PST	Switch Edit PVW output to PST output. (Goes off automatically when other operation disables this command.)		
TL Run Control	Turn timeline effect execution mode on or off.		
Delegation Button (M/E K1 Trans, M/E K2 Trans)	Set the Flexi Pad control block to independent key transition mode	On	–
Effect/Wipe	Set the Flexi Pad control block to effect snapshot mode	On	Off
Snapshot	Set the Flexi Pad control block to snapshot mode		
Macro	Set the Flexi Pad control block to macro mode		
Transition Rate	Set the Flexi Pad control block to transition rate input mode		
Timeline	Set the Flexi Pad control block to timeline mode		
Device Control	Set the Flexi Pad control block to device control mode		

a) Unless otherwise specified, lit in amber

b) Can only be selected when Enable/Utility is selected in step 3 under “Assigning utility commands” (see page 219).

c) [?] is the GPI number selected in step 5 under “Assigning utility commands” (see page 219).

## Key Setup (Key Menu)

Use the Key menu to make settings related to keys, such as key memory and the show key function.

### Selecting the key memory operating mode

See “Using Key Memory” (page 122), for more information about key memory.

- 1 From the top menu, select Setup/Diag >Operation >Key.

The Key menu appears. The current key and key memory operating mode, key bus cross-point hold mode, and mask/border processing order settings appear in the status area.

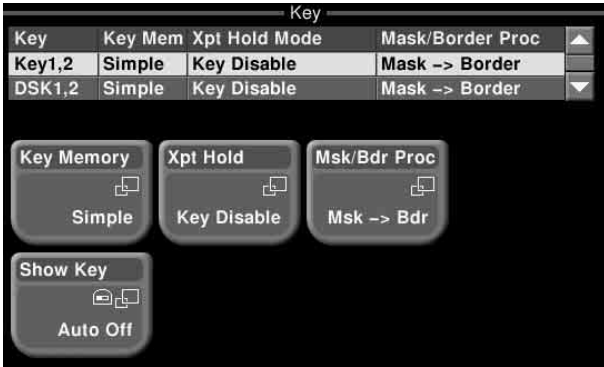

**2** Using any of the following methods, select the target key.

- Press directly on the list in the status area.
- Use the arrow buttons to scroll the reverse video cursor.
- Turn the knob.

Knob	Description	Setting values
1 (Key)	Key selection	1, 2 <sup>a)</sup>

a) 1: Key1, 2  
2: DSK1, 2 (1.5 M/E panel only)

**3** Press [Key Memory].

A popup window appears.

**4** Select the key memory operating mode.

- Simple
- Full
- Off

## Setting the key bus cross-point hold mode

You can set the operating mode of the key bus [XP/KY HOLD] button in the AUX bus control block.

The following setting is applicable not only for the [XP/KY HOLD] button but also for the snapshot attributes.

**1** Carry out steps **1** and **2** of “Selecting the key memory operating mode”.

**2** Press [Xpt Hold].

A popup window appears.

**3** Select the cross-point hold mode.

**Key Disable:** The key bus [XP/KY HOLD] button functions as a key disable button. When a snapshot is loaded with the [XP/KY HOLD] button on, key setting data in the snapshot (including cross-point selection data) is ignored.

**Key Disable with Status:** This is the same function as [Key Disable], but additionally key on/off status data is ignored.

**Xpt Hold:** The key bus [XP/KY HOLD] button functions as a cross-point hold button. When a snapshot is loaded with the [XP/KY HOLD] button on, cross-point selection data is ignored.

## Setting mask and border processing order

You can invert the order in which mask and border effects are processed when you apply a mask.

**1** Carry out steps **1** and **2** of “Selecting the key memory operating mode” (see page 222).

**2** Press [Msk/Bdr Proc].

A popup window appears.

**3** Select one of the following.

**Mask → Border:** Mask effect is applied first, then Border effect.

**Border → Mask:** Border effect is applied first, then Mask effect.

## Making show key settings

Enable and disable the show key function, and set the show key output hold interval.

See “Using the Show Key Function” (page 122) for more information about show key.

**1** From the top menu, select Setup/Diag >Operation >Key.

The Key menu appears (see page 222).

### Note

Show key cannot be set individually for Key1 and 2, and DSK1 and 2.

**2** Press [Show Key].

A popup window appears.

**3** Select one of the following.

**Auto Off:** Show key output hold begins when the button is pressed and continues until the set time has elapsed.

**Always On:** Show key output hold begins when the button is pressed and continues until the button is pressed again.

**Off:** Show key output hold function is not available.

**4** If you selected Auto Off in step **2**, turn knob 2 to set the show key output hold time.

Knob	Description	Setting values
2 (Hold Time)	Show key output hold time (frames)	0 to 999

## Settings Relating to Video Switching (Transition Menu)

For settings relating to video switching, use the Transition menu.

The Transition menu has the following items.

**Bus Toggle:** For each of the M/E and PGM/PST banks, switch the bus toggle on or off.

**PST Color Mix:** For each of the M/E and PGM/PST banks, set the stroke mode for a preset color mix and the mode in which the transition type after a transition ends returns to the previous setting.

**FTB:** Enable or disable fade-to-black for each final program output.

**Fader Curve:** Set the relationship when carrying out a transition, between the fader lever position and the advancement state of the transition.

**Bvl Edge Wid:** Set the beveled edge width.

### Setting the Bus Toggle On or Off

- From the top menu, select Setup/Diag >Operation >Transition.

The Transition menu appears.

The status area and button area show the bus toggle, preset color mix, fade-to-black, and fader curve settings.



- When the control panel is a 1.5 M/E panel, select the bank to which the settings apply.

- Press directly on the list appearing in the status area.
- Press the arrow keys to scroll the reverse video cursor.
- Turn the knob.

Knob	Description	Setting values
1 (Bank)	M/E or P/P selection to which settings apply	1, 2

The selected bank appears in reverse video.

- Press [Bus Toggle] to switch between on and off.

**On:** Flip-flop mode

**Off:** Bus fixed mode

#### Note

When using the BZS-8050, select flip-flop mode (set Bus Toggle to On).

### Flip-flop mode and bus fixed mode

The following describes the difference between flip-flop mode and bus fixed mode, taking an M/E bank as an example; the functionality is the same, however, on the PGM/PST bank.

Normally, when a background transition is carried out on the M/E bank, the signals selected on the A and B rows of cross-point buttons are interchanged at the end of the transition. That is to say, except during a transition, the background output is always from the background A bus. This is called “flip-flop mode”.

The alternative is known as “bus fixed mode”, in which there is no bus interchange. In this mode, when the fader lever is at the top of its travel the output from the A bus is always 100%, and when the fader lever is at the bottom of its travel the output from the B bus is 100%.

### Setting a Preset Color Mix

In a normal preset color mix, in the first transition, a single-color matte is gradually mixed into the current image, and in the second transition the new image is gradually mixed into the color matte. In the preset color mix settings, if you select “one-stroke mode”, these two operations are combined into a single transition operation. With the “one-time mode” enabled, when a preset color mix is completed, the transition type always returns to the immediately previous setting. To set a preset color mix, use the following procedure.

- Carry out steps 1 and 2 in the previous item, “Setting the Bus Toggle On or Off”.
  - Press [Stroke Mode].
- A popup window appears.
- Select whether to carry out a transition in one stroke or two strokes.

**2 Stroke:** Carry out a preset color mix with two transition operations.

**1 Stroke:** Carry out a preset color mix with a single transition operation.

**Note**

When the bus toggle mode is off (bus fixed mode), a preset color mix is always in “one-stroke mode”.

- 4 If each time a transition ends the transition type is to return to the previous setting, press [One Time], turning it to Enable.

**Enable:** Each time a transition ends, the transition type returns to the immediately previous setting. (When a transition ends, the [PST COLOR MIX] button goes off.)

**Disable:** Even when a transition ends, the preset color mix remains selected. (The [PST COLOR MIX] button remains lit when the transition ends.)

## Enabling or Disabling the Fade-to-Black Function

You can set this so that no fade-to-black occurs, even when you press the [FTB] button in the downstream key/fade to black control block.

- 1 Carry out step 1 of the procedure for “Setting the Bus Toggle On or Off” (*see page 223*).

- 2 Press [FTB] to toggle between Enable and Disable.

**Enable:** When the [FTB] button is pressed, a fade-to-black is carried out.

**Disable:** Even when the [FTB] button is pressed, no fade-to-black is carried out.

## Settings Relating to Fader Lever Operations

To select the way in which the fader lever position and the transition progress are related, use the following procedure.

- 1 Carry out step 1 of the procedure for “Setting the Bus Toggle On or Off” (*see page 223*).

- 2 Press [Fader Curve].

A popup window appears.

- 3 Select the fader lever operation mode.

**Normal:** The transition progress is linear, according to the fader lever position.

**Advanced Tally Mode:** When the fader lever is moved from the end of its travel, the tally is output slightly before the transition starts.

## Setting the beveled edge width

It is possible to align the outer sides of beveled edges with the borders.

- 1 From the top menu, select Setup/Diag >Operation >Transition.

The Transition menu appears.

- 2 Press [Bvl Edge Wid].

A popup menu appears.

- 3 Select one of the following.

**4:3 (or 16:9):** Gives edges by the fixed aspect ratio of 4:3 (or 16:9).

**Even:** Gives even edges to all four sides on the basis of the border width setting.

**Note**

The setting is included in DME setup. Even if the startup mode is set to resume mode, the system starts up with the custom mode settings as for DME at power on.

## Macro Execution Mode Settings (Macro Menu)

Use the Macro menu to select the macro execution mode.

*For more information about macros, see “Macros” (page 169).*

- 1 From the top menu, select Setup/Diag >Operation >Macro.

The Macro menu appears.

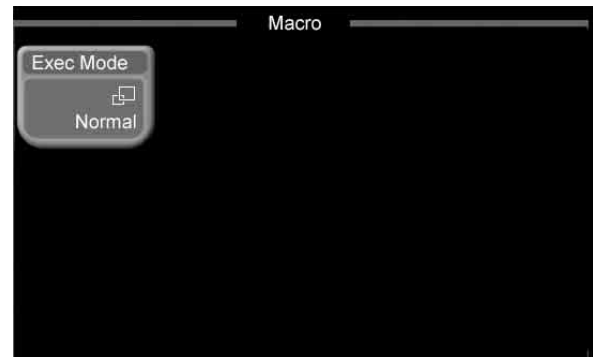

- 2 Press [Exec Mode].

A popup window appears.

- 3 Select the macro execution mode.

**Normal:** Execution of the next event starts automatically when a macro event finishes executing.

**Step:** Execution pauses when a macro event finishes executing.

## Snapshot/Timeline Settings (Snapshot/Timeline Menu)

Carry out settings relating to snapshots and the timeline.

For details of snapshots see page 153, and for details of the timeline see page 159.

### Setting the regions included in “Misc”

In snapshot and timeline operations, the color background and frame memory regions are handled together as “Misc”. For each of these, it is possible to specify inclusion or exclusion, thus changing the definition of the regions included in “Misc”.

#### Note

When the regions included in “Misc” are changed, existing region configuration snapshot data and timeline data can no longer be used.

- 1 From the top menu, select Setup/Diag >Operation >Snapshot/Timeline.

The Snapshot / Timeline menu appears.

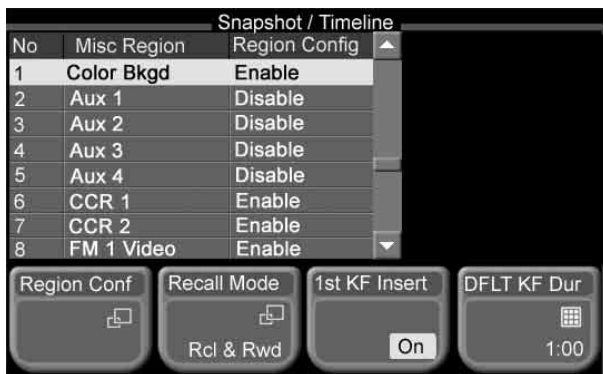

- 2 Press [Region Conf].

A popup window appears.

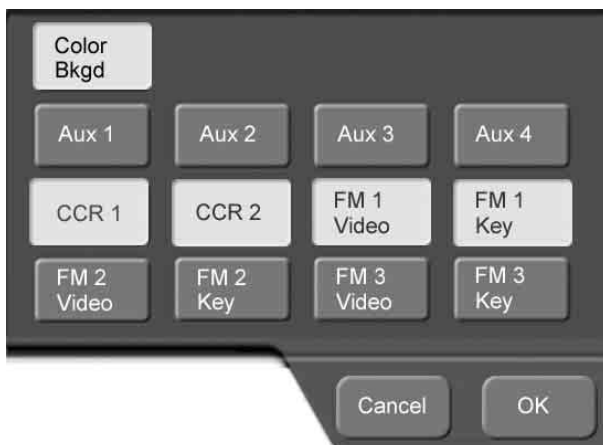

- 3 For a region to be included in “Misc”, press the button, reversing the display. Regions not included in “Misc” appear in normal video.
- 4 Press [OK].  
The popup window closes.

### Setting the status of the first keyframe when recalling the timeline

- 1 In the Snapshot/Timeline menu, press [Recall Mode].  
A popup window appears.
- 2 Press one of the following.
  - Recall & Rewind:** When the timeline is recalled, the first keyframe is shown.
  - Recall:** When the timeline is recalled, the first keyframe is not shown.

### Automatically creating the first keyframe when an empty register is recalled

When an empty register is recalled, you can set the current state to be automatically inserted as the first keyframe. In the Snapshot/Timeline menu, press [1st KF Insert], turning it on.

### Setting the default value of the keyframe duration

- 1 In the Snapshot/Timeline menu, press [DFLT KF Dur].  
A numeric keypad popup window appears.
- 2 Enter the default value of the keyframe duration, in the format “seconds:frames”, then press [ENTR].  
This sets the initial value for the keyframe duration.

## Button Assignments (Button Assign Menu)

Carry out the button assignments for various operations.

### Changing the assignment of mode selection buttons in the Flexi Pad control block

You can assign any of EFF/WIPE, SNAP SHOT, MCRO, TRANS RATE, TIMELINE, DEV CTRL, M/E K1 TRANS and M/E K2 TRANS operation mode to the four mode selection buttons in the Flexi Pad control block.

- 1 From the top menu, select Setup/Diag >Operation >Button Assign.

The Button Assign menu appears.

- 2 In the menu screen, press the display of the Flexi Pad control block.

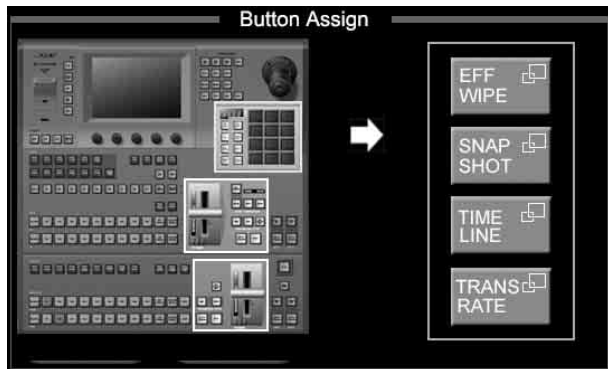

- 3 Press the indication for the button whose assignment you want to change.

A popup window appears.

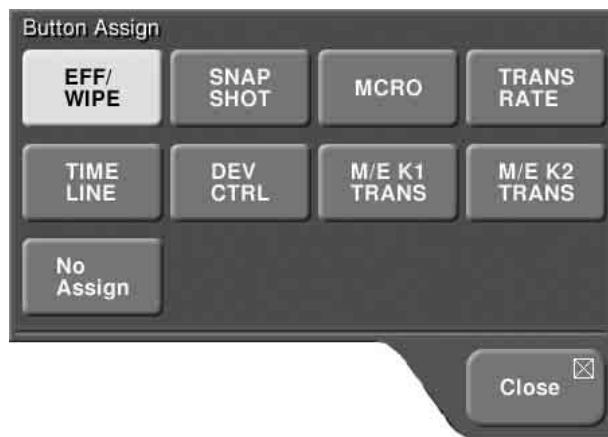

- 4 Press the button for the new function you want to assign.

If you do not want to assign any function, press “No Assign”.

If assignments conflict, the earlier assignment is invalid.

## Changing the function of the transition type selection button in the transition control block

- 1 In the Button Assign menu, press the indication of the transition control block.

The current settings appear as shown in the following figure. (Example shows a 1.5 M/E panel.)

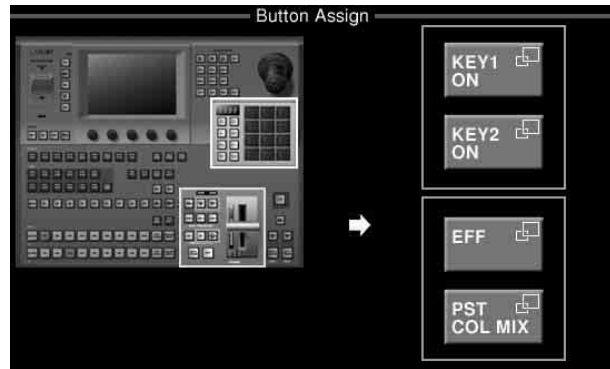

- 2 Press the desired button indication ([EFF] or [PST COL MIX]).

A popup window appears.



- 3 Press one of the following to select the function assigned to this button.

**EFF:** Selecting the [EFF] or [WIPE] (or [WIPE] on the PGM/PST bank).

**PST COL MIX:** Selecting the preset color mix

**TL FADER:** Switching the fader lever function between timeline effect execution and transition execution

**FM1 CLIP to FM3 CLIP:** Selecting the clip transition

## Assigning the auto independent key transition function to an M/E transition control block

You can assign the auto transition function for an independent key transition to the [KEY1 ON] and [KEY2 ON] buttons of the M/E transition control block of an MKS-2010 control panel (1 M/E panel).

The following procedure describes the case of assignment to the [KEY1 ON] button. Use a similar procedure for the [KEY2 ON] button.

- 1 From the top menu, select Setup/Diag >Operation >Button Assign.

The Button Assign menu appears.

- 2 In the menu screen, press the indication of transition control block.

The current assignment appears on the right.

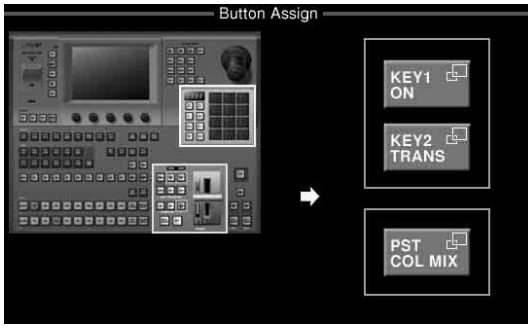

- 3 Press the indication (KEY1 ON) for the button whose assignment you want to change.

A popup window appears.



- 4 Press [KEY1 TRANS].

This assigns the auto transition function to the [KEY1 ON] button for an independent key transition of key 1.

## GPI Input/Output Setup (GPI Menu)

Use the GPI menu to set up GPI signal inputs and outputs between the switcher, control panel or DCU (MKS-8700/2700) and external devices.

### To enable GPI input to the switcher or control panel

You need to enable GPI input before you can use GPI input signals. Do this in the Enable/Safe Title menu.

- 1 From the top menu, select Misc >Enable/Safe Title.

The Enable/Safe Title menu appears.

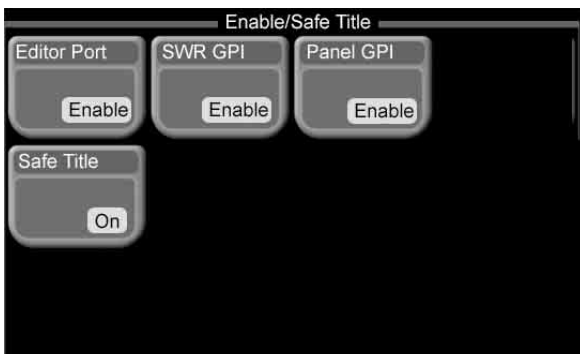

- 2 Press the button for the type of GPI input to enable.

**To enable GPI input to the switcher:** Press [SWR GPI], setting it to [Enable].

**To enable GPI input to the control panel:** Press [Panel GPI], setting it to [Enable].

### Setting switcher GPI inputs

- 1 From the top menu, select Setup/Diag >GPI >SWR GPI In.

The SWR GPI Input menu appears. The status area shows the GPI input ports, and the trigger type and action set for the signal to be input to each port.



- 2 Select the port for which you want to make the setting.

- Press directly on the list in the status area.
- Use the arrow buttons to scroll the reverse video cursor.
- Turn the knobs. (E.g.: if the setting by knob 1 is value 5 and the setting by knob 2 is value 1, this is shown as 5-1.)

Knob	Description	Setting values
1 (Port)	GPI input port number selection	1 to 8
2 (No)	Number selection to which action is to be assigned	1 to 8

### To change the trigger type setting

Press [Trigger Type], to display a popup window, and select the trigger type.

(falling edge): Trigger is applied on the falling edge of an input pulse.

(rising edge): Trigger is applied on the rising edge of an input pulse.

(both edges): Trigger is applied on both falling and rising edges of an input pulse.

**Disable (disabled):** Input pulses are ignored.

### To change the action setting

Press [Action], to display a popup window, and select the action.

Action button	Status area display
M/E Auto Trans	M/E AT
M/E Cut	M/E Cut
P/P Auto Trans <sup>a)</sup>	P/P AT
P/P Cut <sup>a)</sup>	P/P Cut
M/E Key1 Auto Trans	M/E K1 AT
M/E Key1 Cut	M/E K1 Cut
M/E Key2 Auto Trans	M/E K2 AT
M/E Key2 Cut	M/E K2 Cut
DSK1 Auto Trans	DSK1 AT
DSK1 Cut	DSK1 Cut
DSK2 Auto Trans	DSK2 AT
DSK2 Cut	DSK2 Cut
FTB Auto Trans	FTB AT
FTB Cut	FTB Cut
Snapshot Recall ? <sup>b)</sup>	Snapshot
No Action	No Action
FM V Field Freeze	FM V Field
FM V Frame Freeze	FM V Frame
FM V Freeze Off	FM V Off
FM K Field Freeze	FM K Field
FM K Frame Freeze	FM K Frame
FM K Freeze Off	FM K Off
FM V Clip Record	FM V Rec
FM V Clip Stop	FM V Stop
FM K Clip Record	FM K Rec
FM K Clip Stop	FM K Stop
FM1 V Clip Cueup	FM1 V Cue
FM1 V Clip Play	FM1 V Play
FM1 V Clip Stop	FM1 V Stop
FM1 K Clip Cueup	FM1 K Cue
FM1 K Clip Play	FM1 K Play
FM1 K Clip Stop	FM1 K Stop
FM2 V Clip Cueup	FM2 V Cue
FM2 V Clip Play	FM2 V Play
FM2 V Clip Stop	FM2 V Stop
FM2 K Clip Cueup	FM2 K Cue
FM2 K Clip Play	FM2 K Play
FM2 K Clip Stop	FM2 K Stop
FM3 V Clip Cueup	FM3 V Cue
FM3 V Clip Play	FM3 V Play
FM3 V Clip Stop	FM3 V Stop
FM3 K Clip Cueup	FM3 K Cue
FM3 K Clip Play	FM3 K Play
FM3 K Clip Stop	FM3 K Stop

Action button	Status area display
M/E TL Recall ? <sup>b)</sup>	M/E TL Rcl
M/E TL Rcl ? & Run <sup>b)</sup>	M/E Rcl Run
M/E TL Run	M/E TL Run
M/E TL Stop	M/E TL Stop
M/E TL Rewind	M/E TL Rwd
M/E TL Rev Run	M/E Rv Run
P/P TL Recall ? <sup>b) c)</sup>	P/P TL Rcl
P/P TL Rcl ? & Run <sup>c)</sup>	P/P Rcl Run
P/P TL Run <sup>c)</sup>	P/P TL Run
P/P TL Stop <sup>c)</sup>	P/P TL Stop
P/P TL Rewind <sup>c)</sup>	P/P TL Rwd
P/P TL Rev Run <sup>c)</sup>	P/P Rv Run
Misc TL Recall ? <sup>b)</sup>	Misc TL Rcl
Misc TL Rcl ? & Run <sup>b)</sup>	Misc Rcl Run
Misc TL Run	Misc TL Run
Misc TL Stop	Misc TL Stop
Misc TL Rewind	Misc TL Rwd
Misc TL Rev Run	Misc Rv Run

a) 1.5 M/E panel only

b) When this action is selected, press [Register No] to set a register number (1 to 99).

c) For the 1 M/E panel, "DSK" is displayed in place of "P/P".

## Setting switcher GPI outputs

- From the top menu, select Setup/Diag > GPI > SWR GPI Out.

The SWR GPI Output menu appears. The status area shows the GPI output ports, and the trigger type, output timing, pulse width, and action set for the signal to be output from each port.



- Select the port for which you want to make the setting.

- Press directly on the list in the status area.
- Use the arrow buttons to scroll the reverse video cursor.
- Turn the knob.

Knob	Description	Setting values
1 (Port)	GPI output port number selection	1 to 16 <sup>a)</sup>

a) Select 1 to 8 for GPI ports (G-1 to G-8), and 9 to 16 for tally ports (T1 to T8).

### To change the trigger type setting

Press [Trigger Type], to display a popup window, and select the trigger type.

 **(falling edge):** The trigger closes the relay contacts or causes a low output level, and this state is maintained for the specified pulse width.

 **(rising edge):** The trigger opens the relay contacts or causes a high output level, and this state is maintained for the specified pulse width.

 **(both edges):** Each time the trigger is activated, the relay switches between open/closed or the output level switches between high/low.

**Status:** Depending on the state, the relay is switched open/closed or the output level is switched high/low.

**Disable (disabled):** No output.

### To change the timing setting

When the trigger type is other than [Status] or [Disable], press [Timing] to display a popup window, and select the timing.

**Any:** Output on the earliest field that can be processed.

**Field 1:** Output on field 1.



**Field 2:** Output on field 2.

### Note

When the following signal formats are selected, it is not possible to set the timing.

- 1080PsF/23.976
- 1080PsF/24
- 1080PsF/25
- 1080PsF/29.97
- 720p/59.94
- 720p/50

### To change the pulse width setting

When the trigger type is  (falling edge) or  (rising edge), turn the knobs to set the pulse width.

Knob	Description	Setting values
2 (Pulse Width)	Pulse width	1 to 60 (fields)

### To change the action setting

Press [Action] to display a popup window, and select the action.

Action button	Status area display
M/E Auto Trans	M/E AT
M/E Cut	M/E Cut
P/P Auto Trans <sup>a)</sup>	P/P AT

Action button	Status area display
P/P Cut <sup>a)</sup>	P/P Cut
M/E Key1 Auto Trans	M/E K1 AT
M/E Key1 Cut	M/E K1 Cut
M/E Key2 Auto Trans	M/E K2 AT
M/E Key2 Cut	M/E K2 Cut
DSK1 Auto Trans	DSK1 AT
DSK1 Cut	DSK1 Cut
DSK2 Auto Trans	DSK2 AT
DSK2 Cut	DSK2 Cut
FTB Auto Trans	FTB AT
FTB Cut	FTB Cut
M/E Key1 On	M/E K1 On
M/E Key2 On	M/E K2 On
DSK1 On	DSK1 On
DSK2 On	DSK2 On
Error Make	Error Make
Error Break	Error Break
Tally Input1	Tally 1
Tally Input2	Tally 2
Tally Input3	Tally 3
Tally Input4	Tally 4
Tally Input5	Tally 5
Tally Input6	Tally 6
Tally Input7	Tally 7
Tally Input8	Tally 8
Tally Input9	Tally 9
Tally Input10	Tally 10
Tally Input11	Tally 11
Tally Input12	Tally 12
Tally Input13	Tally 13
Tally Input14	Tally 14
Tally Input15	Tally 15
Tally Input16	Tally 16
Tally M/E	Tally M/E
No Action	No Action

a) 1.5 M/E panel only

### To test fire the trigger output

Select the output port, and press [Test Fire].

### Note

When the selected output port trigger type is [Status], no trigger is output.

## Setting control panel GPI inputs

1 From the top menu, select Setup/Diag >GPI >Panel GPI In.

The Panel GPI Input menu appears. The status area shows the GPI input ports, and the trigger type and action set for the signal to be input to each port.

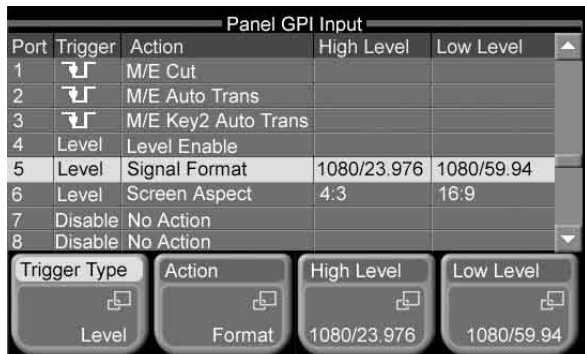

2 Select the port for which you want to make the setting.

- Press directly on the list in the status area.
- Use the arrow buttons to scroll the reverse video cursor.
- Turn the knob.

Knob	Description	Setting values
1 (Port)	GPI input port number selection	1 to 8

### To change the trigger type setting

Press [Trigger Type], to display a popup window, and select the trigger type.

(falling edge): Trigger is applied on the falling edge of an input pulse.

(rising edge): Trigger is applied on the rising edge of an input pulse.

(both edges): Trigger is applied on both falling and rising edges of an input pulse.

**Level:** Trigger is applied when input is low level or high level.

**Disable (disabled):** Input pulses are ignored.

### To change the action setting

When the trigger type is other than [Level] and [Disable], press [Action] to display a popup window, then you can select the following actions.

#### Note

If you change the trigger type setting from any of falling edge, rising edge, and both edges to [Level], or vice versa, the action is automatically changed to [No Action].

*For details of the action when the trigger type is set to [Level], see the next item, “Setting the action when the trigger type is [Level]”.*

Action button	Status area display
M/E Auto Trans	M/E AT
M/E Cut	M/E Cut
P/P Auto Trans <sup>a)</sup>	P/P AT
P/P Cut <sup>a)</sup>	P/P Cut
M/E Key1 Auto Trans	M/E K1 AT
M/E Key1 Cut	M/E K1 Cut
M/E Key2 Auto Trans	M/E K2 AT
M/E Key2 Cut	M/E K2 Cut
DSK1 Auto Trans	DSK1 AT
DSK1 Cut	DSK1 Cut
DSK2 Auto Trans	DSK2 AT
DSK2 Cut	DSK2 Cut
FTB Auto Trans	FTB AT
FTB Cut	FTB Cut
Snapshot Recall <sup>? b)</sup>	SnapShot
No Action	No Action
FM V Field Freeze	FM V Field
FM V Frame Freeze	FM V Frame
FM V Freeze Off	FM V Off
FM K Field Freeze	FM K Field
FM K Frame Freeze	FM K Frame
FM K Freeze Off	FM K Off
FM V Clip Record	FM V Rec
FM V Clip Stop	FM V Stop
FM K Clip Record	FM K Rec
FM K Clip Stop	FM K Stop
FM1 V Clip Cueup	FM1 V Cue
FM1 V Clip Play	FM1 V Play
FM1 V Clip Stop	FM1 V Stop
FM1 K Clip Cueup	FM1 K Cue
FM1 K Clip Play	FM1 K Play
FM1 K Clip Stop	FM1 K Stop
FM2 V Clip Cueup	FM2 V Cue
FM2 V Clip Play	FM2 V Play
FM2 V Clip Stop	FM2 V Stop
FM2 K Clip Cueup	FM2 K Cue
FM2 K Clip Play	FM2 K Play
FM2 K Clip Stop	FM2 K Stop
FM3 V Clip Cueup	FM3 V Cue
FM3 V Clip Play	FM3 V Play
FM3 V Clip Stop	FM3 V Stop
FM3 K Clip Cueup	FM3 K Cue
FM3 K Clip Play	FM3 K Play

Action button	Status area display
FM3 K Clip Stop	FM3 K Stop
Macro Take	Macro Take
Macro Recall ?	Macro Recall
Aux Bus Override <sup>c)</sup>	AUX O_Ride
Timeline Recall ? <sup>b)</sup>	TL Recall
Timeline Run	TL Run
Timeline Stop	TL Stop
Timeline Rewind	TL Rewind

- a) 1.5 M/E panel only  
b) When this action is selected, press [Register No] to set a register number (1 to 99).  
c) [AUX Bus Override] appears only when the trigger type is “falling edge” or “rising edge”. If you select this action, press [Aux No] and [Input No] to select the AUX bus number (1 to 4) and the input source number (1 to 16).

### Setting the action when the trigger type is [Level]

When the trigger type is [Level], press [Action] to display a popup window, then you can select the following four actions.

Action button	Status area display
No Action	No Action
Signal Format	Format
Screen Aspect	Aspect
Level Enable	Enable

When other than [No Action] is selected, you can set the action separately for when the input is high level and when the input is low level. To set the action when the input is high level, press [High Level], and to set the action when the input is low level, press [Low Level], to display a popup window.

**When [Signal Format] is selected:** In the popup window, press any of the following action buttons, to select the action when the input goes to the high level/low level.

- 576i/50
- 480i/59.94
- 720p/50
- 720P/59.94
- 1080i/50
- 1080i/59.94
- 1080PsF/23.976
- 1080PsF/24
- 1080PsF/25
- 1080PsF/29.97
- No Action

**When [Screen Aspect] is selected:** In the popup window, press the following action buttons, to select the action when the input goes to the high level/low level.

- 4:3
- 16:9
- No Action

**When [Level Enable] is selected:** In the popup window, press the following buttons, to select the action when the input goes to the high level/low level.

- Enable
- Disable
- No Action

### Note

When using [Signal Format] and [Screen Aspect], set the [Level Enable] GPI input to [Enable]. If this is not set to [Enable], the GPI inputs are not valid.

### GPI outputs of the control panel

The GPI outputs of the control panel are fixed as follows, so you need not make settings for them.

Port number	Action
GPI-1	Error Status
GPI-2	No Action
GPI-3	No Action
GPI-4	No Action
GPI-5	M/E Key1 On Status
GPI-6	M/E Key2 On Status
GPI-7	DSK1 On Status
GPI-8	DSK2 On Status

### Assigning GPI inputs to DCU parallel input ports

You can assign GPI inputs to DCU parallel input ports which are not being used for tally external box input and tally enable input.

See “Tally Setup (System Tally Menu)” (page 234) for more information about tally external box input and tally enable input.

- 1 From the top menu, select Setup/Diag > GPI > DCU In Config.

The DCU Input Config menu appears.

The status area shows a list of DCU input ports with their current signal assignments.

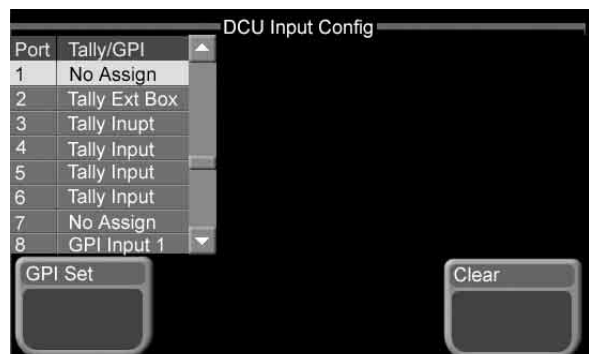

**2** Using any of the following methods, select an input port for the assignment. You can choose either a port with no current assignment (No Assign), or a port with an assignment. Then select the GPI input to assign.

- Press directly on the list in the status area.
- Use the arrow buttons to scroll the reverse video cursor.
- Turn the knobs.

Knob	Description	Setting values
1 (Port)	DCU input port number selection	1 to 102 <sup>a)</sup>
2 (GPI)	GPI input number selection	1 to 50

a) For the MKS-2700, set in the range 1 to 34.

**3** Press [GPI Set].

### To clear GPI input assignments

Select an input port, as in step **2** of the above procedure, then press [Clear].

## Setting DCU GPI inputs

**1** From the top menu, select Setup/Diag >GPI >DCU GPI In.

The DCU GPI Input menu appears.

The status area shows the GPI input ports and the trigger type and action settings of the signals input to each port.

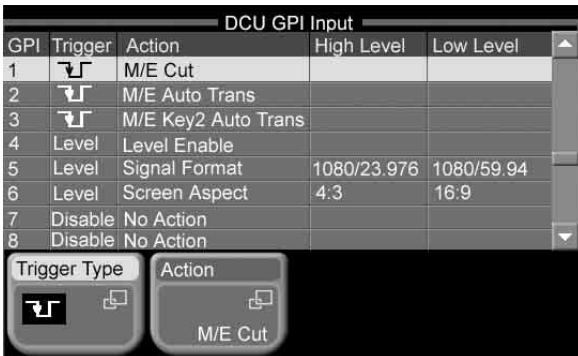

**2** Using any of the following methods, select the GPI input to set.

- Press directly on the list in the status area.
- Use the arrow buttons to scroll the reverse video cursor.
- Turn the knob.

Knob	Description	Setting values
1 (GPI)	GPI input number selection	1 to 50

### To change trigger type settings

Press [Trigger Type] to display a popup window, then select the trigger type.

(falling edge): Trigger is applied on the falling edge of an input pulse.

(rising edge): Trigger is applied on the rising edge of an input pulse.

(both edges): Trigger is applied on both falling and rising edges of an input pulse.

**Level:** Trigger is applied when the input changes to low or high.

**Disable (disabled):** Ignore input pulses.

### To change action settings

When the trigger type is other than [Level] or [Disable], you can press [Action] to display a popup window and select from the actions in the following table.

#### Note

If you change the trigger type setting from any of falling edge, rising edge, and both edges to [Level], or vice versa, the action is automatically changed to [No Action].

*For details of the action when the trigger type is set to [Level], see “Setting the action when the trigger type is [Level]” (page 231).*

Operating button	Status area display
M/E Auto Trans	M/E AT
M/E Cut	M/E Cut
P/P Auto Trans <sup>a)</sup>	P/P AT
P/P Cut <sup>a)</sup>	P/P Cut
M/E Key1 Auto Trans	M/E K1 AT
M/E Key1 Cut	M/E K1 Cut
M/E Key2 Auto Trans	M/E K2 AT
M/E Key2 Cut	M/E K2 Cut
DSK1 Auto Trans	DSK1 AT
DSK1 Cut	DSK1 Cut
DSK2 Auto Trans	DSK2 AT
DSK2 Cut	DSK2 Cut
FTB Auto Trans	FTB AT
FTB Cut	FTB Cut
Snapshot Recall ? <sup>b)</sup>	Snapshot
No Action	No Action
FM V Field Freeze	FM V Field
FM V Frame Freeze	FM V Frame
FM V Freeze Off	FM V Off
FM K Field Freeze	FM K Field
FM K Frame Freeze	FM K Frame
FM K Freeze Off	FM K Off

Operating button	Status area display
FM V Clip Record	FM V Rec
FM V Clip Stop	FM V Stop
FM K Clip Record	FM K Rec
FM K Clip Stop	FM K Stop
FM1 V Clip Cueup	FM1 V Cue
FM1 V Clip Play	FM1 V Play
FM1 V Clip Stop	FM1 V Stop
FM1 K Clip Cueup	FM1 K Cue
FM1 K Clip Play	FM1 K Play
FM1 K Clip Stop	FM1 K Stop
FM2 V Clip Cueup	FM2 V Cue
FM2 V Clip Play	FM2 V Play
FM2 V Clip Stop	FM2 V Stop
FM2 K Clip Cueup	FM2 K Cue
FM2 K Clip Play	FM2 K Play
FM2 K Clip Stop	FM2 K Stop
FM3 V Clip Cueup	FM3 V Cue
FM3 V Clip Play	FM3 V Play
FM3 V Clip Stop	FM3 V Stop
FM3 K Clip Cueup	FM3 K Cue
FM3 K Clip Play	FM3 K Play
FM3 K Clip Stop	FM3 K Stop
Macro Take	Take
Macro Recall?	Macro Recall
AUX Bus Override <sup>c)</sup>	AUX O_Ride
Timeline Recall ? <sup>b)</sup>	TL Recall
Timeline Run	TL Run
Timeline Stop	TL Stop
Timeline Rewind	TL Rewind

a) 1.5 M/E panel only

b) When this action is selected, press [Register No] to set a register number (1 to 99).

c) [AUX Bus Override] appears only when the trigger type is “falling edge” or “rising edge”. If you select this action, press [Aux No] and [Input No] to select the AUX bus number (1 to 4) and the input source number (1 to 16).

## Assigning GPI outputs to DCU parallel output ports

You can assign GPI outputs to DCU parallel output ports which are not being used for parallel tally output.

See “Tally Setup (System Tally Menu)” (page 234) for more information about parallel tally output.

**1** From the top menu, select Setup/Diag >GPI >DCU Out Config.

The DCU Output Config menu appears.

The status area shows the signals assigned to DCU output ports.

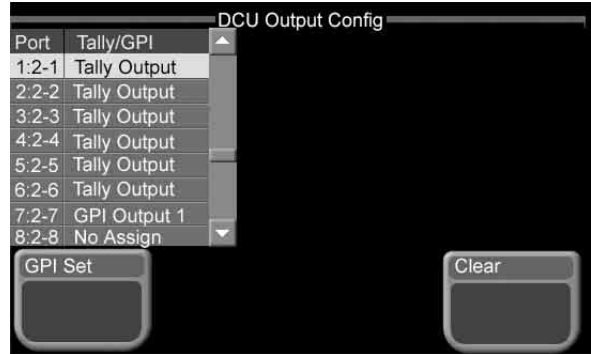

**2** Using any of the following methods, select an output port for the assignment. You can choose either a port with no current assignment (No Assign), or a port with an assignment. Then select the GPI output to assign.

- Press directly on the list in the status area.
- Use the arrow buttons to scroll the reverse video cursor.
- Turn the knobs.

Knob	Description	Setting values
1 (Port)	DCU output port selection	1 and upwards <sup>a)</sup>
2 (GPI)	GPI output number selection	1 to 50

a) Output port numbers are sequential numbers with respect to number pairs, the pairs consisting of a slot number (2 to 6) and a port number (1 to 54).

MKS-2700: Uses slot 2 only. Settings can be made in the range 1 to 36.

MKS-8700: The setting range varies depending on the number of slots used.

**3** Press [GPI Set].

### To clear GPI output assignments

Select an output port, as explained in step 2 of the previous procedure, then press [Clear].

### Setting DCU GPI outputs

**1** From the top menu, select Setup/Diag >GPI >DCU GPI Out.

The DCU GPI Output menu appears.

The status area shows the trigger type, output timing, pulse width, and action settings of each GPI output signal.

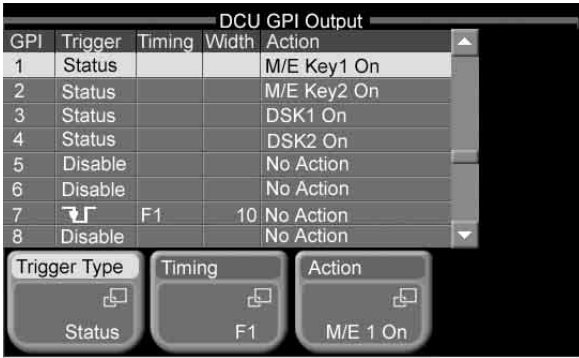

**2** Using any of the following methods, select the GPI output to set.

- Press directly on the list in the status area.
- Use the arrow buttons to scroll the reverse video cursor.
- Turn the knob.

Knob	Description	Setting values
1 (GPI)	GPI output number selection	1 to 50

### To change trigger type settings

Press [Trigger Type] to display a popup window, then select the trigger type.

**(falling edge):** Trigger is applied on the falling edge of an input pulse.

**(rising edge):** Trigger is applied on the rising edge of an input pulse.

**(both edges):** Trigger is applied on both falling and rising edges of an input pulse.

**Status:** Trigger is applied when the relay status changes to open or closed, or when the level changes to low or high.

**Disable (disabled):** Input pulses are ignored.

### To change output timings

When the trigger type is other than [Status] or [Disable], you can press [Timing] to display a popup window and select from the following timings.

**Any:** Output on the earliest field that can be processed.

**Field 1:** Output on field 1.

**Field 2:** Output on field 2.

#### Note

You cannot set the timing when any of the following signal formats are selected.

- 1080PsF/23.976
- 1080PsF/24
- 1080PsF/25
- 1080PsF/29.97
- 720P/59.94
- 720p/50

### To change pulse widths

When the trigger type is other than [Status] or [Disable], turn knob 2 to set the pulse width.

Knob	Description	Setting values
2 (Pulse Width)	Pulse width	1 to 60 (fields)

### To change action settings

When the trigger type is [Status], you can press [Action] to display a popup window and select from the actions shown in the following table.

Operating button	Status area display
M/E Key1 On	M/E K1 On
M/E Key2 On	M/E K2 On
DSK1 On	DSK1 On
DSK2 On	DSK2 On
Error Make	Error Make
Error Break	Error Break
Device Recording	Device Rec
No Action	No Action
Editor GPI ? a)	Editor GPI

a) When [Editor GPI ?] is selected, press [GPI No] and select an Editor GPI number (1 to 32).

When the trigger type is other than [Status], the only possible selections are [No Action] and [Editor GPI ?].

#### Note

[Editor GPI ?] can be used only when you have a valid license for the BZS-8050 Editing Control Software.

## Tally Setup (System Tally Menu)

For details of the setup for tally signals to be output from the switcher to external devices, see “Setting switcher GPI outputs” in the section “GPI Input/Output Setup (GPI Menu)” (page 227).

Use the System Tally menu to make settings related to system tally.

### Assigning switcher inputs and outputs to the S-Bus space

The MFS-2000 system uses the S-Bus protocol as its interface to routers (routing switchers). Therefore it is necessary to assign inputs and outputs of the switcher and so on to an S-Bus space.

**1** From the top menu, select Setup/Diag >System Tally >S-Bus Assign.

The S-Bus Assign menu appears. The status area shows the matrix size, source addresses, destination addresses, and levels.

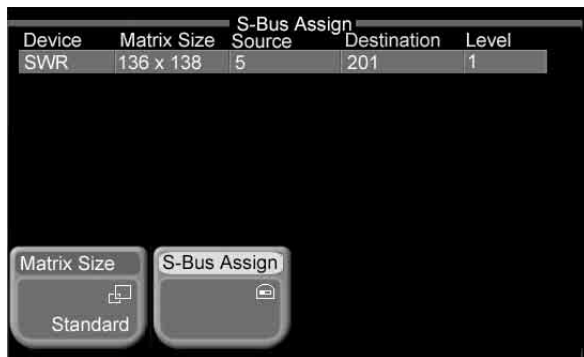

**2** Press [Matrix Size].

A popup window appears.

**3** Select the matrix size.

**Standard 136 × 138:** Assign the switcher S-Bus space at full size. You can assign all switcher inputs and outputs to the S-Bus space, but this causes some waste of S-Bus space.

**Compact 128 × 128:** Assign the switcher S-Bus space at compact size. It is not possible to assign all switcher inputs and outputs to the S-Bus space, but the S-Bus space can be used efficiently.

**4** Press [S-Bus Assign].

**5** Turn the knobs to set the following parameters.

Knob	Description	Setting values
1 (Source)	Source start address	1 to 889 <sup>a)</sup> 1 to 897 <sup>b)</sup>
2 (Destination)	Destination start address	1 to 887 <sup>a)</sup> 1 to 897 <sup>b)</sup>
3 (Level)	Level in S-Bus space	1 to 8

a) When matrix size is Standard 136 × 138

b) When matrix size is Compact 128 × 128

## Making external box settings

If you need to acquire the signal selection status of external devices via parallel input, assign a matrix to S-Bus space as an external selector (external box).

**1** From the top menu, select Setup/Diag >System Tally >External Box.

The External Box menu appears. The status area shows a list of device names, matrix sizes, source addresses, destination addresses, and levels. “No Assign” appears in the [Matrix Size] column of unused external boxes.

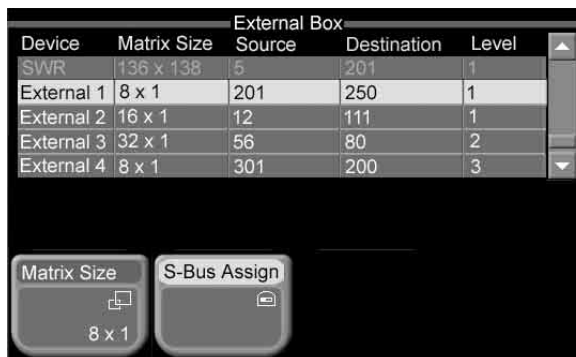

### Note

The switcher (SWR) is displayed, but cannot be set here. To make switcher settings, use the S-Bus Assign menu.

**2** Using any of the following methods, select the external box to set.

- Press directly on the list in the status area.
- Use the arrow buttons to scroll the reverse video cursor.
- Turn the knob.

Knob	Description	Setting values
1 (Ext Box No)	External box selection	1 to 4

**3** Press [Matrix Size].

A popup window appears.

**4** Select the matrix size

**No Assign:** Do not use.

**8 × 1:** Select an external box with 8 inputs and 1 output.

**16 × 1:** Select an external box with 16 inputs and 1 output.

**32 × 1:** Select an external box with 32 inputs and 1 output.

**5** Press [S-Bus Assign].

**6** Turn the knobs to set the following parameters.

Knob	Description	Setting values
2 (Source)	Source start address	1 to 1017 <sup>a)</sup> 1 to 1009 <sup>b)</sup> 1 to 993 <sup>c)</sup>
3 (Destination)	Destination start address	1 to 1024
4 (Level)	Level in S-Bus space	1 to 8

a) When matrix size is 8 × 1

b) When matrix size is 16 × 1

c) When matrix size is 32 × 1

## To couple external boxes

For the external boxes that you want to connect, set the same destinations and levels in step 6.

By coupling a number of external boxes, you can increase the number of inputs.

Example:

External box 1: set to 8 × 1 size

External box 2: set to 32 × 1 size

By coupling these two external boxes, you obtain 40 inputs (=8+32).

## Making tally group settings

With the S-Bus protocol, tally control is possible for groups 1 to 8, but in this system you can use either groups 1 to 4 or groups 5 to 8. You can select whether or not to transfer tally information over the S-Bus, and select the type of grouping.

- 1 From the top menu, select Setup/Diag >System Tally >Group Tally.

The Group Tally menu appears.

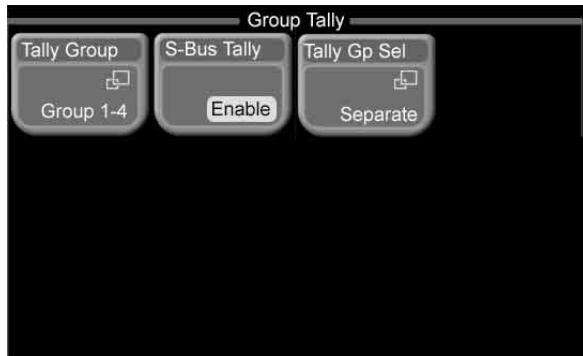

- 2 Press [Tally Group].

A popup window appears.

- 3 Select the groups to use.

**Group 1-4:** Use groups 1 to 4.

**Group 5-8:** Use groups 5 to 8.

- 4 Press [S-Bus Tally] to select whether or not to transfer tally information over the S-Bus.

Each press toggles between On (transfer) and Off (do not transfer).

- 5 Press [Tally Gp Sel].

A popup window appears.

- 6 Select the type of grouping.

**Separate:** Do not group. Transfer tally information separately for each of the eight tallies.

**4 Groups Connect:** Group the data areas of Group 1 to 4 (or Group 5 to 8) and transfer as the tally information of Group 1 (or Group 5).

**2 Groups Connect:** Group data areas in pairs Group 1/2 and Group 3/4 (or Group 5/6 and Group 7/8) and transfer as the tally information of Group 1 (or Group 5) and Group 3 (or Group 7).

## Making tally generation settings

Use the following procedures to make tally generation settings by setting destination, tally type, and input port parameters, and to modify existing settings.

### To make new tally generation settings

- 1 From the top menu, select Setup/Diag >System Tally >Tally Enable.

The Tally Enable appears. The status area shows tally setting information.

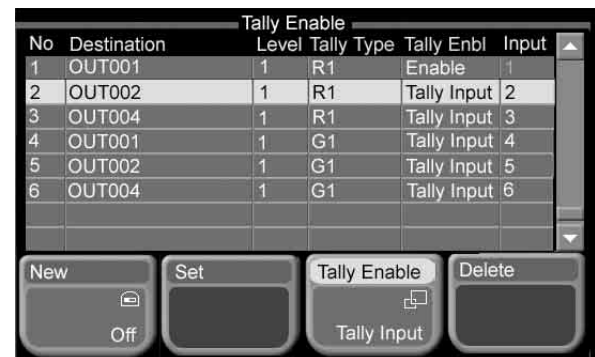

- 2 Press [New], turning it on, and turn the knobs to set the following parameters.

Knob	Description	Setting values
2 (Dest Add)	Source/destination address	1 to 1024
3 (Dest Lvl)	Destination level	1 to 8
4 (Tally Type)	Tally type	1 (R1) to 8(G4) <sup>a)</sup>

a) The tally type display changes according to the tally group in use (R is red tally, and G is green tally).

Tally group	Tally type
Group 1-4	1: R1, 2: G1, 3: R2, 4: G2, 5: R3, 6: G3, 7: R4, 8: G4
Group 5-8	1: R5, 2: G5, 3: R6, 4: G6, 5: R7, 6: G7, 7: R8, 8: G8

- 3 Press [Tally Enable].

A popup window appears.

- 4 Set the tally generation conditions.

**Tally Input:** Generate a tally when a tally input port is active.

**Enable:** Always generate a tally.

**Disable:** Never generate a tally.

- 5** If you selected Tally Input in step **4**, turn knob 5 to select the tally input port.

Knob	Description	Setting values
5 (Input No)	Tally input port number	1 to 102 <sup>a)</sup>

a) For the MKS-2700, set in the range 1 to 34.

- 6** Press [Set].

### To modify existing tally settings

- 1** If [New] is on, turn it off.
- 2** Using any of the following methods, select the tally settings to modify.
- Press directly on the list in the status area.
  - Use the arrow buttons to scroll the reverse video cursor.
  - Turn the knob.

Knob	Description	Setting values
1 (No)	Tally selection	1 and upwards

- 3** With reference to steps **2** to **5** in the preceding section “Making new tally generation settings”, change the parameters as required.

- 4** Press [Set].

### To delete tally generation settings

Select tally settings by carrying out steps **1** and **2** of the previous procedure “To modify existing tally settings”, then press [Delete].

### Making parallel tally settings

Proceed as follows to set the source and destination addresses, level, and tally type for each parallel port.

- 1** From the top menu, select Setup/Diag >System Tally >Parallel Tally.

Parallel Tally menu appears. The status areas shows setting information for each port.



- 2** Using any of the following methods, select a tally output port.

- Press directly on the list in the status area.
- Use the arrow buttons to scroll the reverse video cursor.
- Turn the knobs.

Knob	Description	Setting values
1 (Slot)	Slot number selection	2 to 6 <sup>a)</sup>
2 (Port)	Port number selection	1 to 54 <sup>b)</sup>

a) For the MKS-2700, set to 2.

b) For the MKS-2700, set in the range 1 to 34.

- 3** Press [Src/Dest].

A popup window appears.

- 4** Select whether to assign a source or a destination to the port.

**Source:** Assign a source.

**Dest:** Assign a destination.

- 5** Turn the knobs to set the following parameters.

Knob	Description	Setting values
3 (Address)	Source or destination address	1 to 1024
4 (Level)	Destination level	1 to 8 <sup>a)</sup>
5 (Tally Type)	Tally type	1 (R1) to 8 (G4) <sup>b)</sup>

a) The level setting is required only when destination was selected in step **4**.

b) The tally type display changes according to the tally group in use (R is red tally, and G is green tally).

Tally group	Tally type
Group 1-4	1: R1, 2: G1, 3: R2, 4: G2, 5: R3, 6: G3, 7: R4, 8: G4
Group 5-8	1: R5, 2: G5, 3: R6, 4: G6, 5: R7, 6: G7, 7: R8, 8: G8

- 6** Press [Set].

### To delete parallel tally settings

In step 2, select a tally port and press [Clear].

### Making wiring settings

When configuring a system in which the switcher inputs and outputs are connected to a router, it is necessary to set up this connection configuration (referred to as “wiring”) in the S-Bus space.

#### To make new wiring settings

- From the top menu, select Setup/Diag >System Tally Wiring.

The Wiring menu appears. The status area shows wiring information.



- Press [New], turning it on, and turn the knobs to set the following parameters.

Knob	Description	Setting values
1 (Dest From)	Destination start address	1 to 1024
2 (Dest To)	Destination end address	1 to 1024
3 (Dest Lvl)	Destination level	1 to 8
4 (Src From)	Source start address	1 to 1024
5 (Src Lvl)	Source level	1 to 8

- Press [Set].

#### To modify wiring settings

- If [New] is on, turn it off.
- Using any of the following methods, select the wiring setting to modify.

- Press directly on the list in the status area.
- Use the arrow buttons to scroll the reverse video cursor.
- Turn the knob.

Knob	Description	Setting values
1 (No)	Wiring number selection	1 and upwards

- Turn the knobs to set the following parameters.

Knob	Description	Setting values
2 (Dest Add)	Destination address	1 to 1024
3 (Dest Lvl)	Destination level	1 to 8
4 (Src Add)	Source address	1 to 1024
5 (Src Lvl)	Source level	1 to 8

- Press [Set].

#### To sort wiring settings

- Select a wiring setting by carrying out steps 1 and 2 of “To modify wiring settings”, then press [Sort].

A popup window appears.

- Execute the sort by selecting one of the following sort orders.

##### Dest: Destination level/address

The wiring settings are sorted as follows.

Ascending order (smallest first) by destination

level → ascending order by destination address

→ ascending order by source level → ascending order by source address.

##### Source: Source level/address

The wiring settings are sorted as follows.

Ascending order (smallest first) by source level

→ ascending order by source address →

Ascending order by destination level →

ascending order by destination address.

#### To delete wiring settings

Select a wiring setting by carrying out steps 1 and 2 of “To modify wiring settings”, then press [Delete].

### Copying tallies

You can copy tally source information to another tally source.

#### To make new tally copy settings

- From the top menu, select Setup/Diag >System Tally >Tally Copy.

The Tally Copy menu appears. The status area shows the current tally copy settings.



- Press [New], turning it on, then turn the knobs to set the following parameters.

Knob	Description	Setting values
1 (CP FR (FR))	Copy-from source start address	1 to 1024
2 (CP FR (To))	Copy-from source end address	1 to 1024
3 (CP To (FR))	Copy-to source start address	1 to 1024

- Press [Set].  
A new tally copy setting based on the settings made in step 2 is added.

### To modify tally copy settings

- If [New] is on, turn it off.
- Using any of the following methods, select the setting to change.

- Press directly on the list in the status area.
- Use the arrow buttons to scroll the reverse video cursor.
- Turn the knob.

Knob	Description	Setting values
1 (No)	Copy setting selection	1 and upwards

- Turn the knobs to set the following parameters.

Knob	Description	Setting values
2 (CP From)	Copy-from source	1 to 1024
3 (CP To)	Copy-to source	1 to 1024

- Press [Set].

### To sort tally copy settings

- Select a copy setting by carrying out steps 1 and 2 of “To modify tally copy settings”, then press [Sort].

A popup window appears.

- Select one of the following to execute the sort.

- From Source:** Sort in ascending order (smallest first) by From Source name.
- To Source:** Sort in ascending order by To Source name.

### To delete tally copy settings

Select a copy setting by carrying out steps 1 and 2 of “To modify tally copy settings”, then press [Delete].

## External Device Connection Port Setup (Device Menu)

To control external devices connected to the RS-422A 9-pin serial ports of the DCU, use the Device menu to make port settings.

See “Controlling External Devices” (page 195) for more information about controlling external devices.

### Assigning devices to DCU ports

- From the top menu, select Setup/Diag >Device >Port Assign.

The Port Assign menu appears. The status area shows a list of devices currently assigned to ports, together with information about how they are controlled.

Device control settings are made in the Device Assign menu. For details, see page 240.

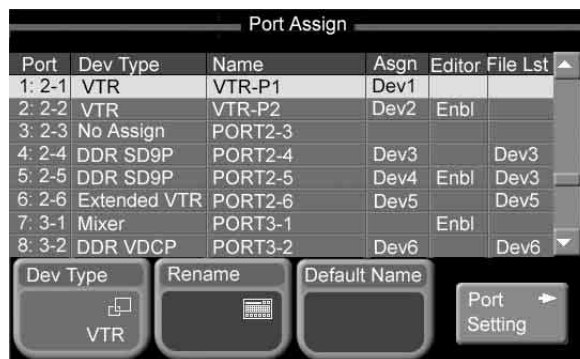

- Using any of the following methods, select the target port for a device assignment.

- Press directly on the list in the status area.
- Use the arrow buttons to scroll the reverse video cursor.
- Turn the knob.

Knob	Description	Setting values
1 (Port)	Port selection	1 and upwards <sup>a)</sup>

a) Output port numbers are sequential numbers with respect to number pairs, the pairs consisting of a slot number (2 to 6) and a port number (1 to 54).

MKS-2700: Uses slot 2 only. Settings can be made in the range 1 to 36.

MKS-8700: The setting range varies depending on the number of slots used.

### 3 Press [Dev Type].

A popup window opens.

### 4 Select the type of device to assign.

**VTR:** VTR

**DDR SD9P:** Disk recorder (Sony Disk 9-pin Protocol)

**DDR VDCP:** Disk recorder (Video Disk Communications Protocol)

**Extended VTR:** Extended VTR

**Mixer:** Audio mixer

**No Assign:** No assignment

### 5 Press [Port Setting] to make the detailed settings required to control the specific device you plan to connect.

See the following sections for more information about how to make detailed settings for the various device types.

- “To make detailed settings for VTRs” (page 241)
- “Making detailed settings for disk recorders (Sony Disk 9-pin Protocol)” (page 242)
- “Making detailed settings for disk recorders (Video Disk Communications Protocol)” (page 242)
- “Making detailed settings for Extended VTRs” (page 243)

#### Note

Audio mixers cannot be operated from this system. If you have a valid BZS-8050 license, operation from an editing keyboard is possible.

#### To rename a port

You can rename ports by assigning names of up to eight characters.

### 1 Select a port by carrying out step 2 of “Assigning devices to ports”.

### 2 Press [Rename].

The keyboard window appears.

### 3 Enter a name and press [Enter].

To return to the default name, press [Default Name].

By default, ports have names in the format “PORT S-P”.

S: A slot number (2 to 6)

P: A port number (1 to 6)

## Making control settings for devices assigned to ports

Make the following settings

- Assignments of devices assigned to the various ports to the device selection buttons (Device1 to Device6)
- Selection of whether or not to operate from an editing keyboard
- For disc recorders and Extended VTRs, selection of devices to share file lists with

### 1 From the top menu, select Setup/Diag >System Tally >Device Assign.

The Device Assign menu appears. The status areas shows the devices assigned to the various ports, together with information about how the devices are controlled.

Port	Dev Type	Name	Asgn	Editor	File Lst
1: 2-1	VTR	VTR-P1	Dev1		
2: 2-2	VTR	VTR-P2	Dev2	Enbl	
3: 2-3	No Assign	PORT2-3			
4: 2-4	DDR SD9P	PORT2-4	Dev3		Dev3
5: 2-5	DDR SD9P	PORT2-5	Dev4	Enbl	Dev3
6: 2-6	Extended VTR	PORT2-6	Dev5		Dev5
7: 3-1	Mixer	PORT3-1		Enbl	
8: 3-2	DDR VDCP	PORT3-2	Dev6		Dev6

Buttons: Assign (Dev3), Plug In Editor (Disable), File List (Dev3)

### 2 Using any of the following methods, select a target port.

- Press directly on the list in the status area.
- Use the arrow buttons to scroll the reverse video cursor.
- Turn the knob.

Knob	Description	Setting values
1 (Port)	Port number selection	1 and upwards <sup>a)</sup>

a) Output port numbers are sequential numbers with respect to number pairs, the pairs consisting of a slot number (2 to 6) and a port number (1 to 54).

MKS-2700: Uses slot 2 only. Settings can be made in the range 1 to 36.

MKS-8700: The setting range varies depending on the number of slots used.

### 3 Press [Assign].

A popup window appears.

### 4 Select a device selection button, which will select the device on the selected port.

**DEV1 to DEV6:** [Device1] to [Device6] buttons  
**No Assign:** Do not assign a device selection button

- Press [Plug In Editor], and select whether or not to enable operation of the selected device from an editing keyboard.

**Notes**

- A valid BZS-8050 license is required for operation from an editing keyboard.
- When the device on the selected port is an audio mixer, [Enable] is selected automatically. This setting cannot be changed.

**To share file lists**

- Select a port as in step 2, then press [File List].  
A popup window appears.
- Select the devices with which the device on the selected port will share file lists.

**Note**

Select devices of the same type for file list sharing.

**Making detailed settings for devices assigned to DCU ports**

After selecting a device type for a DCU port, you need to make detailed settings to enable control of the external device that you plan to connect to that port. Use the Port Setting menu to make detailed settings for specific devices.

To display the Port setting menu, select the device that you want to set in the status area of the Port Assign menu (*see page 239*) and press [Port Setting].

You can also select a device in the Port Setting menu by turning knob 1.

Knob	Description	Setting values
1 (Port)	Port selection	1 and upwards

To return from the Port Setting to the Port Assign menu, press [Port Assign] in the Port Setting menu.

**Making detailed settings for VTRs**

The following settings are required for VTRs.

- The VTR constants of your VTR
- Selection of the timecode source (signal used to derive timecode for determining tape position)

The status area of the Port Setting menu for VTR devices shows information about the selected port and a list of the bytes in the VTR constants.

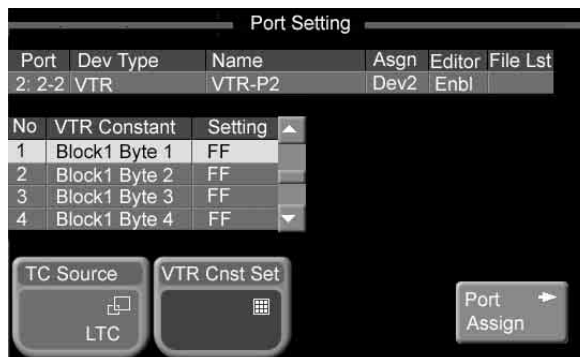

VTR detailed settings screen

- Using any of the following methods, select a VTR constant byte to set.

- Press directly on the list in the status area.
- Use the arrow buttons to scroll the reverse video cursor.
- Turn the knob.

Knob	Description	Setting values
3 (No)	VTR constant selection	1 to 16

- Press [VTR Cnst Set].

The hexadecimal keypad window (*see page 39*) appears.

- Enter a value and press [Enter].

This sets one byte of the VTR constants. Return to step 1 and repeat as required.

- Press [TC Source].

A popup window appears.

- Select the timecode source.

**LTC:** Use LTC only.

**LTC:VITC:** Switch automatically between LTC and VITC.

**CTL:** Use CTL pulses or timer counter pulses. Select this only for tapes on which no timecode is recorded.

**VTR constant settings**

Set VTR constant values in the range from 00 to FF for the following items.

Block	Byte	Setting
Block1	1	HI-BYTE (DEVICE TYPE)
	2	LO-BYTE (DEVICE TYPE)
	3	HI-BYTE (FRAME) (PREROLL TIME)
	4	LO-BYTE (FRAME) (PREROLL TIME)
	5	EDIT DELAY (FRAME)
	6	EE DELAY (FRAME)
	7	OVER RUN (FRAME)
	8	TRAJECTORY
Block2	1	TC READ DELAY (FRAME)
	2	START DELAY (FRAME)
	3	AFTER SYNC DELAY -
	4	AFTER SYNC DELAY +
	5	MODE1
	6	MODE2
	7	MAX PRRL SPEED
	8	QUICK PVW PRRL TIME (FRAME)

### Making detailed settings for disk recorders (Sony Disk 9-pin Protocol)

For disk recorders using the Sony Disk 9-pin Protocol (called “DDR SD9P” below), settings are required to specify response times until command execution.

The status area of the Port Setting menu for DDR SD9P devices shows information about the selected port and a list of response times.



DDR SD9P detailed settings screen

**1** Using any of the following methods, select a response time to set.

- Press directly on the list in the status area.
- Use the arrow buttons to scroll the reverse video cursor.
- Turn the knob.

Knob	Description	Setting values
3 (No)	Setting item selection	1 to 4 <sup>a)</sup>

a) 1: Maximum Open Delay (maximum time required to open a file)  
2: Maximum Cueup Delay (maximum time required to cue up a file)

- 3: Play After Cueup Delay (delay time from the cued-up state to begin playback)
- 4: Play After Open Next Delay (delay time from the Open Next state to begin playback)

**2** Turn knob 4 to set the response time.

Knob	Description	Setting values
4 (Setting)	Response time	0 to 255

**3** Press [Set].

The setting is confirmed.

### Making detailed settings for disk recorders (Video Disk Communications Protocol)

The following settings are required for disk recorders using the Video Disk Communications Protocol (called “DDR VDCP” below).

- Selection of whether to use the disk recorder as a recorder or as a player
- Video port number
- Response times until command execution
- File name mode
- Timecode sense

The status area of the Port Setting menu for DDR VDCP devices shows information about the selected port, a video port, and a list of response times.

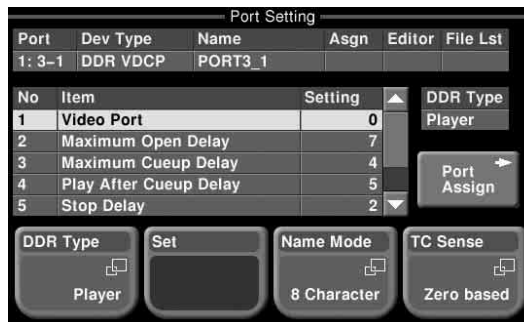

DDR VDCP detailed settings screen

**1** Press [DDR Type].

A popup window opens.

**2** Select Player or Recorder.

- Player:** Functions as player.
- Recorder:** Functions as recorder.

**3** Using any of the following methods, select the video port or a response time to set.

- Press directly on the list in the status area.
- Use the arrow buttons to scroll the reverse video cursor.
- Turn the knob.

Knob	Description	Setting values
3 (No)	Setting item selection	1 to 7 <sup>a)</sup>

- a) 1: Video Port (port associated with the serial port being set. The output port of a player, and the input port of a recorder.)  
 2: Maximum Open Delay (maximum time required to open a file)  
 3: Maximum Cueup Delay (maximum time required to cue up a file)  
 4: Play After Cueup Delay (delay time from the cued-up state to begin playback)  
 5: Stop Delay (delay time from Stop command to actual stop)  
 6: Still Delay (Time required to stop after issuing the Still command)  
 7: Continue Delay (Time required to stop after issuing the Continue command)

4 Turn knob 4 to set the video port or the response time.

Knob	Description	Setting values
4 (Setting)	Video port number setting	0 to 127 <sup>a)</sup>
	Response time	0 to 255

- a) 0: No assignment

5 Press [Set].

The setting is confirmed.

6 Press [Name Mode].

A popup window appears.

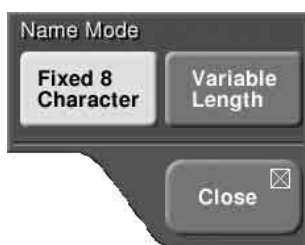

7 Select either of the following file name modes.

**Fixed 8 Character:** Handle eight-character fixed-length file names

**Variable Length:** Handle variable-length file names (In the MFS-2000 system, file names are limited to a maximum of 23 characters.)

8 Press [TC Sense].

A popup window appears.

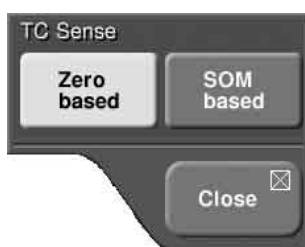

9 Select either of the following timecode senses, according to the protocol that the connected device supports.

**Zero based:** Mode in which the timecode is sensed with the first frame of the recalled file as 00:00:00:00  
**SOM based:** Mode in which the timecode is sensed with the values recorded in the recalled file

**Note**

The details of the above operating modes depend on the connected device. *For details, refer to the documentation for the connected device.*

**Making detailed settings for Extended VTRs**

For Extended VTRs, settings are required to specify response times until command execution.

The status area of the Port Setting menu for Extended VTR devices shows information about the selected port and a list of response times.

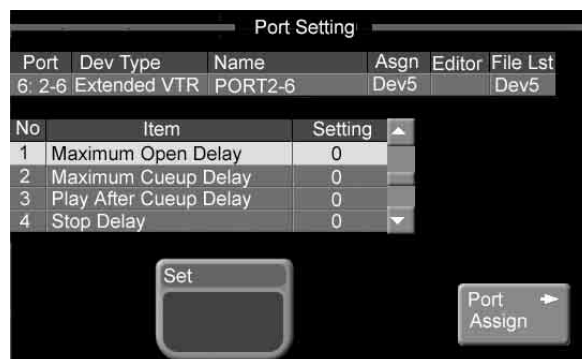

Extended VTR detailed settings screen

1 Using any of the following methods, select a response time to set.

- Press directly on the list in the status area.
- Use the arrow buttons to scroll the reverse video cursor.
- Turn the knob.

Knob	Description	Setting values
3 (No)	Setting item selection	1 to 4 <sup>a)</sup>

- a) 1: Maximum Open Delay (maximum time required to open a file)  
 2: Maximum Cueup Delay (maximum time required to cue up a file)  
 3: Play After Cueup Delay (delay time from the cued-up state to begin playback)  
 4: Stop Delay (delay time from Stop command to actual stop)

2 Turn the knob to set the response time.

Knob	Description	Setting values
4 (Setting)	Response time	0 to 255

3 Press [Set].

The setting is confirmed.

# Index

## A

Advanced Operations  
  effect 103  
  key 117  
All (Selected) menu 181  
All menu 180  
Angle 104  
Animation function 142  
Aspect 103  
Aspect ratio 202  
ATTCH ENBL button 25  
Attributes, snapshot 154  
Audio mixer 195, 240  
Auto chroma key 88  
AUTO TRANS buttons 17, 19  
Auto transition  
  executing 81  
  snapshot 154  
AUX bus control block 15  
AUX Bus Remote Panel (MKS-8080)  
  8  
  simple connection 199  
AUX Bus Remote Panel (MKS-8082)  
  8  
  simple connection 199  
AUX delegation buttons 15

## B

Back button 33  
Background signals 49  
Bank 154  
BANK SEL button 21  
Basic operations  
  changing the position and size of  
    effect patterns 70  
  composing video with keys 83  
  executing transitions 80  
  fading the video to black 100  
  modifying video borders 73  
  preparing transitions 76  
  selecting effects 63  
  selecting transition types 59  
  selecting video 55  
  using internally generated signals  
    95  
  video switching on the M/E bank  
    50  
  video switching on the PGM/PST  
    bank 53  
Basic settings (system settings) 201  
Beveled edge 106

Border  
  adding to keys 90  
  adding to video 74  
  color setting 74, 112, 118  
  softening 75  
Border Color menu 112  
BS button 41  
Bus fixed mode 13, 223  
Bus override 154, 156, 168  
Bus toggle 223  
Button area 34  
Button Assign Menu 225  
BZS-2000M 8, 210  
BZS-2440M 8, 210  
BZS-2470M 8, 210  
BZS-8050 8, 210

## C

Calibration 213  
Caps Lock button 41  
CCR menu 127  
Changing screen position of freeze  
  images 140  
Channel  
  selecting from menus 68  
  selecting with the buttons 68  
Chroma key 88  
  adjusting manually 119  
  adjusting video 89  
  adjusting video signals 121  
  auto chroma key 88  
  color cancel 119  
  composition method 118  
  key active 119  
  selecting a key fill 88  
  selecting a key source 88  
  shadows 121  
  window 120  
  Y balance 120  
Chroma Key menu 118  
Clean mode 117  
Clear button  
  hexadecimal keypad window 40  
  keyboard window 42  
  numeric keypad window 39  
  page number input window 42  
Clip 144  
  Creation 144  
  Playback 145  
  Recalling 144  
  Utility Control Block 145  
Clip Transition 149  
Close button  
  hexadecimal keypad window 40  
  keyboard window 41  
  numeric keypad window 39  
  page number input window 42

Color 1 setting 95  
Color background 95  
Color Bkgd menu 95  
Color correction 126  
  CCR menu 127  
  copy or swap 127  
  input video processing 128  
  luminance processing 131  
  masking 129  
  output video processing 133  
  primary color correction 128  
  RGB clip 130  
  secondary color correction 130  
  spot color adjustment 132  
  YUV clip 133  
Color Corrector Board (MKS-2420M)  
  8  
Color mixing 96  
Composing frame memory video 138  
Composite function 138  
Control from editing systems 193  
Control Panel  
  1 M/E panel 10, 12  
  1.5 M/E panel 10, 11  
  1.5 M/E wide panel 10, 11  
Copying 178  
Copying or swapping color corrector  
  settings 127  
Creating a pair from a video signal and  
  key signal 207  
Crop menu 105  
Cropping  
  crop mode 217  
  effects 105  
Cross-point button numbers 13, 204  
Cross-point button rows 13, 14, 16  
Cross-point buttons  
  assigned signals 206  
  assigning signals 204, 206  
Cross-point hold 154  
Cue up 196  
Custom mode 202, 203  
Cut (transition) 81  
CUT button 17

## D

Date/Time menu 212  
Date/time setting 212  
DCU 195  
DDR SD9P 242  
DDR VDCP 242  
Default recall 33, 39, 46  
Del button 42  
Delay mode 118  
Delegation selection buttons 23  
Detail Information menu 209  
Device Control Unit (MKS-2700) 8

- Device Control Unit (MKS-8700) 8
- Device ID 210
- Device menu 239
- DEVICE/UTILITY operation buttons 24
- Diamond dust effect 105
- Disk recorder (supporting Sony Disk 9-pin protocol) 195, 242
- Disk recorder (supporting Video Disk Communications Protocol) 195, 242
- DME Board Set (MKS-2470) 8
- DME Upgrade Software (BZS-2470M) 8, 210
- Double clicking 28
- Downstream key 84
- Downstream key/fade to black control block 19
- Drop border 90
- DSK independent transition execution section 19
- DSK PVW button 19
- Dust Mix 105

## E

- Edge
  - separate edge 118
  - softening 75
- Edge (or border) 90
- Edge menu 118
- EDIT/STORE button 21
- Editing Control Software (BZS-8050) 8, 210
- Editing Keyboard (MKS-2050) 8
- Editing Keyboard (MKS-8050) 8
- Effect
  - non-transition effects 67
  - selecting 63
  - selecting from menus 65
  - selecting the background of a 2-channel effect 58
  - selecting with the Flexi Pad control block 64
  - transition effects 67
  - types 67
- Effect direction
  - selecting from menus 79
  - selecting with the Effect/Wipe control block 79
- Effect dissolve 154
- Effect modifier buttons 23

- Effect pattern
  - arranging several examples 104
  - changing the aspect ratio 103
  - changing the position and size 70
  - modulation 104
  - rotation 103
  - specific transformations 112
  - transforming 103
- Effect snapshot
  - deleting 115
  - recalling 115
  - saving 114
- Effect/Wipe control block 22
- ENABLE/UTILITY operation buttons 24
- Enhanced group 66
- Enter button
  - hexadecimal keypad window 40
  - keyboard window 42
  - numeric keypad window 39
  - page number input window 42
- Event 169
- Exporting
  - image files 189
- Extended VTR 195, 243
- External box 235
- External device connection port setup 239
- External device operations 193
- External Hard Disk Drive 151
  - Formatting 151
  - Recalling 152
  - Saving 152
- External Media Support 192

## F

- Fade to black 100
- Fader lever 17
  - non-sync state 81
- File list (disk recorder/Extended VTR) 197

- File operations 179
  - batch operating on data files 180
  - batch operating on data files of selected categories 181
  - copying data files 186
  - deleting all data at once 181
  - deleting individual data files 184
  - deleting the data of selected categories 182
  - directory operations 190
  - loading all data at once 180
  - loading individual data files 183
  - loading the data of selected categories 182
  - operating on individual data files 183
  - renaming data files 185
  - saving all data at once 180
  - saving individual data files 183
  - saving the data of selected categories 181
- Fine key function 117
- Fine mode 23, 71, 168
- Flexi Pad control block 20
- Flip-flop mode 13, 223
- Flow of operations
  - changing the position and size of effect patterns 70
  - composing video with keys 83
  - executing transitions 80
  - fading the video to black 100
  - modifying video borders 73
  - preparing transitions 76
  - selecting effects 63
  - selecting transition types 59
  - selecting video 55
  - using internally generated signals 95
- Format menu 201
- Format settings 201
- Format supported 7
- Frame memory 134
  - clip 144
  - flow of frame memory operations 135
  - still image 134
- Frame Memory Board Set (MKS-2440) 8
- Frame Memory menu 136
  - Composite menu 138
  - Create Timeline menu 142
  - Delete menu 147
  - Freeze menu 136
  - Recall menu 137
  - Record menu 141
  - Rename menu 146
  - Reposition menu 140
- Frame Memory Upgrade Software



(BZS-2440M) 8, 210  
Freeze image 134  
Freezing images 136  
FTB button 19  
Fwd button 33

## G

GPI input/output setup 227  
GPI inputs setting  
    control panel 230  
    switcher 227  
GPI menu 227  
GPI outputs  
    control panel 231  
    switcher 228  
GPI outputs setting 228

## H

H Modulation 104  
HD system 217  
Hexadecimal keypad window 39  
HK-PSU02 8  
HK-PSU11 8

## I

Icons displayed on buttons 35  
Illegal color limiter, setting 213  
Image File Operations 146  
Importing  
    DME effects 189  
    image files 187  
Initialization 214  
Initialize menu 214  
Input Adjust menu 214  
Input reference signal 202  
Input signal setup 214  
Input string display 41  
Input value display 42  
Input video processing 128  
Input/Output Connector Board (MKS-2110M) 8  
Input/Output menu 214  
Installation key 210  
Internally generated signals 95  
Inverting key signals 117  
Item display 41

## J

Jog/shuttle mode 195  
Joystick 23

## K

### Key

adjusting the key position 117  
advanced operations 117  
border 118  
chroma key 88  
clean mode 117  
copying 178  
downstream key 84  
edge (border) 90  
fine key 117  
independent key transition 93  
inserting and deleting keys 87  
linear key 84  
luminance key 84  
M/E key 84  
masking 91  
moving a key over or under 92  
pattern key 89  
selecting a key fill 86  
selecting a key source 85  
show key 122  
Key Active 119  
Key border 118  
    2-color borders 118  
    maximum border widths 118  
    separate border widths 118  
KEY button 16  
Key disable 154  
Key memory 122  
Key menu 221  
Key priority 92  
Key setup 221  
Key Source menu 117  
KEY1 ON/KEY2 ON button 18, 19  
Keyboard window 40  
Keyframe 162

## L

Left button 41  
License menu 210  
Lighting 108  
Luminance processing 131

## M

M/E cross-point control block 12  
M/E Key 84  
M/E key transition control block 19  
M/E transition control block 16  
Macro 169  
    creating 170  
    deleting 174  
    editing 173  
    recalling and executing 172  
    saving 174  
Macro attachment 175

Macro control block 24  
Macro menu 224  
Magnitude 104  
Main menu  
    effects 65, 68, 72  
    key 84  
Manual Install menu 209  
Mask/border processing order 222  
Masking 91  
    color correction 129  
    Mask menu 121  
    shapes and positions 121  
    transforming a pattern 122  
Memory recall buttons 21  
“Memory Stick” 26  
“Memory Stick” slot 25  
“Memory Stick” status indicator 25  
Menu  
    accessing by double clicking 28  
    accessing by single clicking 31  
    accessing from the top menu 27  
    basic menu operations 43  
    basic screen 32  
    exiting 47  
    icons 35  
    interpreting buttons 34  
    interpreting menu screens 32  
    menu page number button 32  
    selecting by entering page numbers 44  
    selecting by navigating the menu tree 43  
    selecting from the display history 44  
    selecting functions 44  
    setting parameters 44  
Menu control block 25  
Menu switch buttons 33  
Menu title buttons 34  
Mix 60  
MKS-2010 8  
MKS-2015 8  
MKS-2017 8  
MKS-2050 8  
MKS-2110M 8  
MKS-2420M 8  
MKS-2440 8  
MKS-2470 7, 8  
MKS-2700 8  
MKS-8050 8  
MKS-8080 8, 199  
MKS-8082 8, 199  
MKS-8700 8  
Mode selection buttons 21  
Modify (Ptn No.0001-0999) menu 103  
Modifying video borders 73  
    Soft Edge/Soft Border 75

Modulation 104  
Multi 104

## N

NAM (non-additive mix) 67  
Names and functions of parts 9  
Next transition  
    selecting 62  
    selection buttons 17  
Non-sync state 81  
Non-transition effect 67  
Normal execution mode 172  
Numeric display 20  
Numeric keypad window 37

## O

1 M/E panel 10  
1.5 M/E panel 10  
1.5 M/E wide panel 10  
Operation menu 204  
Options 8  
    entering an installation key 211  
Outline 90  
Output 215  
Output Assign menu 203  
Output Clip menu 216  
Output Crop menu 217  
Output signal assignment 203  
Output signal setup 215  
Output video processing 133  
OVER indicators 18  
Overview 7

## P

Page number input window 42  
Pair file 147  
Pair number 206  
Panel GPI Input menu 230  
Panel maintenance 212  
Panel menu 212  
Parameter buttons 34  
Parameter group 45  
Parameters, setting 44  
Pattern key 89  
    transforming the pattern 121  
Pattern Key menu 121  
Pattern Limit 113  
Pattern position and size  
    changing from menus 72  
    changing with the joystick 71  
Pause event 170  
PGM/PST cross-point control block  
    14  
PGM/PST transition control block 18  
Phase adjustments through mode  
    setting 214

Plane function 119  
Popup windows 36  
    scrolling type 37  
Positioner 71  
POST MCRO button 25  
Power indicators 25  
Power Supply Unit (for control panels)  
    (HK-PSU11) 8  
Power Supply Unit (for MFS-2000)  
    (HK-PSU02) 8  
PRE MCRO button 24  
Preset color mix 60  
Primary color correction 128  
Processing key signals 117

## R

Recalling freeze images 137  
Recalling freeze images sequentially  
    142  
Recording a series of images 141  
Recording function 141  
Reentry buttons 14  
Reference Out menu 217  
Reference output 217  
Reference signal 202  
Region 154  
    timeline 161  
Region selection buttons 21  
Register 153  
    effect snapshots 115, 153  
    macro 169, 176  
    snapshots 156  
    timeline 160  
Reposition function 140  
Resume mode 202  
RGB clip 130  
Right button 41  
Rotation 103

## S

Safe title 178, 218  
Saving setup 208  
Saving the initial status 208  
S-Bus space 234  
Screen aspect ratio 202  
Secondary color correction 130  
Selecting video  
    AUX bus 57  
    M/E 56  
    PGM/PST 57  
Separate edge 118  
Setting data  
    returning them to default values  
        46  
Shadow 90, 110  
SHIFT button 13, 14, 16

Shift button 41  
Shift mode 206  
Show key 122, 222  
Shutdown 47  
Signal format 201  
Single clicking 31  
Single file 147  
Snapshot 153  
    bus override 154  
    deleting 156  
    number of registers 153  
    recalling 155  
    saving 154  
    temporary attributes 154  
    types 153  
Snapshot/Timeline Menu 225  
Soft edge/soft border 75  
Software, installing 209  
Speed 104  
Spot color adjustment 132  
SRC BUS button 15  
Standard group 67  
Start TC 197  
Startup mode 202  
Startup Mode menu 202  
Status area 34  
Step execution mode 173  
Still image 134  
Sub Menu area 28  
Super mix 67  
Switcher Upgrade Software (BZS-  
    2000M) 8, 210  
Switching timing 213  
SWR GPI Input menu 227  
SWR GPI Output menu 228  
System  
    adjustments 213  
    basic settings 201  
    features 7  
    initialization 214  
    installing software 209  
    other settings 212  
    reset 214  
System Adjust menu 213  
System phase 213  
System settings 201  
System Tally menu 234

## T

Tally 234  
Tally copy 238  
Tally group 236  
Tally indicators 14, 15  
Tally setup 234  
Temporary attributes 154  
Through mode 214, 216  
Thumbnail 136

Timecode source 241  
Timecode window 37  
Timeline 159  
    deleting data 168  
    editing keyframes 163  
    editing registers 169  
    executing a timeline effect 168  
    flow of timeline operations 159  
    inserting keyframes to the timeline 162  
    keyframe 162  
    preparations 160  
    recalling data 167  
    recalling the register to save the timeline 160  
    region 161  
    saving 167  
    setting a path 166  
    setting times 165  
    specifying edit points 163  
    Timeline menu 161  
Timeline effect 168  
Timeline menu 161  
Top Menu area 28  
Top menu selection buttons 25  
Trail 109  
Transition  
    clip transition 149  
    executing 80  
    preparing 76  
    selecting transition types 59, 60  
Transition effect 67  
Transition execution section  
    M/E 17  
    PGM/PST 18  
Transition indicator 17  
Transition menu 60  
Transition rate  
    setting from menus 77  
Transition rate display section 17  
Transition rates  
    setting with the Flexi Pad control block 77  
Transition type selection buttons  
    M/E 18  
    PGM/PST 18

**U**

Unique device ID 210  
USB connector 25  
User programmable DME effects 112, 189  
Using 112  
Utility commands 220  
Utility control block 24  
Utility menu 218

## V

V Blank/Through menu 216  
V Modulation 104  
Variable speeds 197  
Version information 209  
    detail information 209  
    Detail Information menu 209  
Version Information menu 209  
Vertical blanking 216  
Video clip adjustment 216  
Video Process menu 215  
Video process setting 215  
Video switching  
    M/E bank 50  
    PGM/PST bank 53  
Video/Key Pair Assign menu 207  
VTR 195, 241  
VTR constant 241

## W

Window (for chroma key adjustment) 120  
Window Hold button 37  
Wipes 67  
Wiring 238

## X

XP/KY HOLD button 16  
Xpt Assign menu 206  
XPT HOLD button 13, 14

## Y

Y balance, adjusting 120  
YUV clip 133

## Z

zing 136

The material contained in this manual consists of information that is the property of Sony Corporation and is intended solely for use by the purchasers of the equipment described in this manual.

Sony Corporation expressly prohibits the duplication of any portion of this manual or the use thereof for any purpose other than the operation or maintenance of the equipment described in this manual without the express written permission of Sony Corporation.

MFS-2000  
(SY)  
3-855-579-04(1)

Sony Corporation



<http://www.sony.net/>

Printed on recycled paper.

Printed in Japan  
2008.10.13  
© 2004